

VOLO

LISTINO

06 2024

 LISTINO PREZZI **V2**

 PRICE LIST **V2**



Listino prezzi Giugno 2024

Price list
June 2024



Tutti i nostri pannelli di particelle nobilitati sono a basso contenuto di formaldeide, conformi ai limiti di emissione previsti dal U.S. EPA TSCA Title VI (CARB P2).

Tutti i nostri pannelli di particelle nobilitati provengono da foreste gestite in maniera corretta e responsabile secondo rigorosi standard ambientali, sociali ed economici a dimostrazione di un attivo contributo alla gestione forestale responsabile.

Tutte le misure all'interno del listino sono espresse in centimetri se non diversamente indicato.

All of our melamine-faced particleboard panels have a low formaldehyde content, in compliance with the U.S. EPA TSCA Title VI (CARB P2) emission limits.

All of our melamine-faced particleboard panels are sourced from forests that are properly and responsibly managed in accordance with strict environmental, social and economic standards, demonstrating our active contribution to responsible forest management.

All measurements in the price list are in centimetres unless otherwise stated.

Indice

Tables of contents

Certificazioni	pag. 4	Accessori per armadi con ante battenti	pag. 76	Letti scorrevoli NEW ROLL	pag. 146	Libreria INFINITY terminale - P 33,3	pag. 199
Certifications		Wardrobes with hinged doors accessories		NEW ROLL sliding beds		End-bookshelf INFINITY - Dpt 33.3	
Indice generale dei colori	pag. 5	Cabine ad angolo ELLE	pag. 78	Letti scorrevoli EDGE	pag. 147	COMPONIBILI E PENSILI	pag. 201
General index of colors		ELLE corner walk-in wardrobes		EDGE sliding beds		MODULAR UNITS AND HANGING UNITS	
Compilazione degli ordini con "T GEO - METRON4 - MULTISTANZA"	pag. 6	Cabine ad angolo ESSE	pag. 80	Letti scorrevoli SPIKE	pag. 148	Componibili a terra/in appoggio - P 45,8	pag. 202
Compilation of orders with "T GEO - METRON4 - MULTI-ROOM"		ESSE corner walk-in wardrobes		SPIKE sliding beds		Floor/support modular units - Dpt 45.8	
CARATTERISTICHE	pag. 9	Cabine ad angolo EFFE	pag. 82	Accessori per letti	pag. 149	Componibili sospesi - P 45,8	pag. 208
CHARACTERISTIC		EFFE corner walk-in wardrobes		Beds accessories		Suspended modular units - Dpt 45.8	
Colori, finiture	pag. 10	Angoli interi per armadi - P 56,3	pag. 84	Reti, materassi e guanciali	pag. 150	Accessori per componibili	pag. 210
Colors, finishes		Corner wardrobes - Dpt 56.3		Bed bases, mattresses and pillows		Modular units accessories	
Tessuti, similpelli e microfibre	pag. 12	Terminali - P 56,3	pag. 85	Gruppi	pag. 154	Pensili - P 32,5	pag. 212
Fabrics, faux leather and microfibers		End units - Dpt 56.3		Groups		Hanging units - Dpt 32.5	
Colori (non standard) per sedute	pag. 14	Librerie terminali ORDER - L 32,5 P 54,5 - con contenitore L 30 P 32,5	pag. 86	Specchiere	pag. 156	Accessori per pensili	pag. 214
Colours (not standard) for seats		ORDER end bookshelves - W 32.5 Dpt 54.5 - with cabinet W 30 Dpt 32.5		Mirrors		Hanging units accessories	
Colori ruote	pag. 16	Librerie terminali OLA - L 30,7 P 53,6	pag. 87	SCRIVANIE, MENSOLE E CUBOLOTTI	pag. 159	Moduli sospesi SNAKE	pag. 216
Wheel colours		OLA end bookshelves - W 30.7 Dpt 53.6		DESKS, SHELVES AND CUBES		SNAKE suspended modular units	
Strutture a spalla per Armadi	pag. 18	Librerie terminali SLASH - L 26 P 54,5 - con porta scarpe	pag. 88	Scrivanie BANNER - H 77,6 P 57,1	pag. 160	RESIDENCE E HOTEL	pag. 221
Modular structure for Wardrobes		SLASH end bookshelves - W 26 Dpt 54.5 - with shoe rack		BANNER desks - Ht 77.6 Dpt 57.1		RESIDENCE AND HOTEL	
Strutture per Armadi con ante scorrevoli	pag. 20	Librerie terminali PILL - L 26 P 50,9	pag. 89	Scrivanie WINNER - H 77,6 P 63,5	pag. 162	Elementi per hotel e contract	pag. 222
Structure for Wardrobes with sliding doors		PILL end bookshelves - W 26 Dpt 50.9		WINNER desks - Ht 77.6 Dpt 63.5		Contract and hotel elements	
Strutture ad elementi per Componibili a terra/in appoggio	pag. 22	Armadi con ante scorrevoli FREE - H 225,3 P 61,5	pag. 90	Scrivanie SWITCH - H 77,6 P 63,3	pag. 164	Testate continue su misura e letti accostabili	pag. 224
Element structures for floor/support Modular units		Wardrobes with FREE sliding doors - Ht 225.3 Dpt 61.5		SWITCH desks - Ht 77.6 Dpt 63.3		Custom-made continuous headboards and his beds	
Strutture ad elementi per Componibili sospesi e Pensili	pag. 24	Armadi con ante scorrevoli FREE - H 257,3 P 61,5	pag. 92	Scrivanie ICS - H 77,6 P 57,1	pag. 166	Scheda prodotto	pag. 226
Element structures for Suspended modular units and Hanging units		Wardrobes with FREE sliding doors - Ht 257.3 Dpt 61.5		ICS desks - Ht 77.6 Dpt 57.1		Product information	
Facciate VOLO	pag. 26	Accessori per armadi con ante scorrevoli	pag. 94	Scrivanie CORNER - H 77,6 P 90	pag. 167	Condizioni generali di vendita	pag. 228
VOLO fronts		Wardrobes with sliding doors accessories		CORNER desks - Ht 77.6 Dpt 90		General sales conditions	
Ante WINDOW	pag. 28	Fasce di tamponamento	pag. 96	Scrivanie ARCON con carrello H 77,6 - P 59,5	pag. 168		
WINDOW doors		Filler strips		ARCON desks with trolley Ht 77.6 - Dpt 59.5			
Ante scorrevoli	pag. 30	ARMADI PONTE, LETTI A SOPPALCO E A CASTELLO	pag. 99	Scrivanie ALPA - H 77,6	pag. 169		
Sliding doors		BRIDGE WARDROBES, LOFT AND BUNK BEDS		ALPA desks - Ht 77.6			
Lavorazioni particolari	pag. 32	Armadi a ponte - H 257,6 P 56,3	pag. 100	Scrivanie sospesa FLOW - L 120 P 47,3	pag. 170		
Special processes		Bridge wardrobes - Ht 257.6 Dpt 56.3		FLOW suspended desk - W 120 Dpt 47.3			
MANIGLIE, ACCESSORI, SEDIE E TAVOLI	pag. 35	Letti a soppalco BRIDGE - H 257,6 P 95 - per scaletta in metallo	pag. 102	Accessori per scrivanie	pag. 171		
HANDLES, ACCESSORIES, CHAIRS AND TABLES		BRIDGE loft beds - Ht 257.6 Dpt 95 - for metal ladder		Desks accessories			
Pomelli e maniglie	pag. 36	Letti a soppalco BRIDGE - H 257,6 P 100 - con scaletta laterale	pag. 104	Mensole - Sp 2,5 P 26	pag. 172		
Knobs and handles		BRIDGE loft beds - Ht 257.6 Dpt 100 - with side stair		Shelves - Th 2.5 Dpt 26			
Posizionamento pomelli e maniglie	pag. 42	Accessori per armadi ponte e letti a soppalco	pag. 106	Cubolotti	pag. 174		
Knobs and handles position		Bridge wardrobes and loft beds accessories		Cubes			
Ferramenta	pag. 46	Letti a castello WINNER - H 187 L 101,5 - per scaletta in metallo	pag. 108	Pannelli attrezzati STRIP - P 20	pag. 176		
Hardware		WINNER bunk beds - Ht 187 W 101.5 - for metal ladder		STRIP equipped panels - Dpt 20			
Campionari e vernici	pag. 48	Letti a castello WINNER - H 187 L 101,5 - con scaletta laterale	pag. 109	Pannelli attrezzati BING - P 28,5	pag. 176		
Colour sample sets and paints		WINNER bunk beds - Ht 187 W 101.5 - with side stair		BING equipped panels - Dpt 28.5			
Pannelli e bordi	pag. 48	Letti a castello REVOLUTION - H 198 L 210	pag. 110	Pannelli attrezzati PILL - P 28,5	pag. 177		
Panels and edged		REVOLUTION bunk beds - Ht 198 W 210		PILL equipped panels - Dpt 28.5			
Illuminazione	pag. 49	Letti a castello REVOLUTION - H 198 L 210 - con cabina	pag. 112	Pannelli attrezzati DROP - P 20,5	pag. 177		
Lighting		REVOLUTION bunk beds - Ht 198 W 210 - with walk-in wardrobe		DROP equipped panels - Dpt 20.5			
Appendiabiti	pag. 49	Letti a castello REVOLUTION - H 198 L 210 - con armadio	pag. 114	Pannelli attrezzati EXPILON - P 28,5	pag. 178		
Clothes hook		REVOLUTION bunk beds - Ht 198 W 210 - with wardrobe		EXPILON equipped panels - Dpt 28.5			
Sedie	pag. 50	Accessori per letti a castello REVOLUTION	pag. 116	Pannelli attrezzati porta TV - H 90	pag. 179		
Chairs		REVOLUTION bunk beds accessories		Equipped panels for TV - Ht 90			
Tavoli DALLAS	pag. 52	Letti a castello TITANO - H 179,3 L 200	pag. 118	Pannelli attrezzati STRANGE - H 90	pag. 180		
DALLAS tables		TITANO bunk beds - Ht 179.3 W 200		STRANGE equipped panels - Ht 90			
Ante	pag. 54	LETTI E GRUPPI	pag. 121	LIBRERIA INFINITY	pag. 183		
Doors		BEDS AND GROUPS		INFINITY BOOKSHELF			
Cassetti e cassettoni VOLO	pag. 57	Letti singoli	pag. 122	Libreria INFINITY - Informazioni tecniche	pag. 184		
VOLO drawers and big drawers		Single beds		INFINITY bookshelf - Technical information			
Pannello anta VOLO senza fori cerniera e maniglia	pag. 58	Letti singoli imbottiti	pag. 130	Libreria INFINITY - Ante e cassetti	pag. 188		
VOLO door panel without hinge and handle holes		Padded single beds		INFINITY bookshelf - Doors and drawers			
ARMADI CON ANTE BATTENTI E SCORREVOLI	pag. 61	Turche	pag. 132	Libreria INFINITY - H 195,3 P 33,3	pag. 190		
WARDROBES WITH HINGED AND SLIDING DOORS		Ottomans		INFINITY bookshelf - Ht 195.3 Dpt 33.3			
Armadi con ante battenti - H 225,6 P 56,3	pag. 62	Divani letto	pag. 134	Libreria INFINITY - H 227,3 P 33,3	pag. 192		
Wardrobes with hinged doors - Ht 225.6 Dpt 56.3		Sofa beds		INFINITY bookshelf - Ht 227.3 Dpt 33.3			
Armadi con ante battenti - H 257,6 P 56,3	pag. 68	Giroletti metallici	pag. 135	Libreria INFINITY - H 259,3 P 33,3	pag. 194		
Wardrobes with hinged doors - Ht 257.6 Dpt 56.3		Metal bed frames		INFINITY bookshelf - Ht 259.3 Dpt 33.3			
Armadi porta TV con ante battenti - P 56,3	pag. 74	Letti matrimoniali	pag. 136	Libreria INFINITY - Schiene, ripiani e accessori	pag. 196		
TV wardrobes with hinged doors - Dpt 56.3		Double beds		INFINITY bookshelf - Backs, shelves and accessories			
Elementi JOLLY	pag. 75	Letti matrimoniali imbottiti	pag. 144	Libreria INFINITY angolo intero - P 33,3	pag. 198		
JOLLY elements		Padded double beds		Full corner INFINITY bookshelf - Dpt 33.3			

UNI EN ISO 9001



UNI EN ISO 14001



In ordine alfabetico:
In alphabetical order:

Codici colore
Colour codes

0021	Tela	• T	TG7H	Titan grey
0025	Bianco	TR9M	Trasparente	
0031	Grigio oliva	• V	VE5R	Verde
0402	Zinc	• X	X22K	Grigio
0403	Papyrus	X27A	Lime	
0503	Carioca	X28D	Beige	
0601	Grey	X29G	Giallo	
0604	Greystone	X31H	Azzurro	
0704	Smoke	X32M	Blu	
0706	Steel	• Y	Y33R	Panna
0903	Nox	• Z	Z01B	Bianco
• A		Z02K	Arancio	
AL1A	Alluminio	Z13K	Limone	
AR3T	Argento	Z14G	Viola	
AS7H	Alluminio spazzolato	Z15L	Arancia	
• B		Z16R	Blu pervinca	
BI7A	Bianco opaco	Z17W	Fucsia	
BL6R	Blue	Z20B	Bianco candido	
BN7A	Bianco	Z21R	Limo	
BT4R	Trasparente	Z35F	Verde eden	
• C		Z41G	Travertino	
CA7A	Cemento artico	Z62R	Fiordaliso	
CQ3Q	Cadaques	Z64X	Elephant	
CS4B	Champagne spazzolato	Z66H	Riso	
• F		Z67M	Duna	
FT8P	Trasparente fumè	Z68Q	Tabacco	
• G		Z69T	Vinaccia	
GL4R	Grigio Dorian	Z70R	Blu petrolio	
GZ8T	Grigio titanio	Z71U	Grigio medio	
• K		Z75N	Arancio Runner	
K28F	Bianco Luna	Z76R	Beige Runner	
K29K	Sabbia Luna	Z77U	Blu Runner	
K30N	Rosso Luna	Z78X	Grigio Runner	
K31T	Grigio scuro Luna	Z79Y	Senape	
K32W	Bianco Step	Z80B	Dorian	
K33Z	Nero Step	Z81G	Desert	
K38R	Bianco Nice	Z83P	Domy	
K39U	Sabbia Nice	Z84S	Zafferano	
K40X	Nero Nice	Z85V	Opale	
• L		Z82L	Titanio	
LV5T	Oliva	Z86Y	Grigio polvere	
• M		Z87B	Porpora	
ML4B	Miele			
• N				
NB5T	Noce brina			
NS3Q	Nero spazzolato			
• O				
OR1S	Oran			
• P				
PP7H	Papaya			
• R				
RC3Q	Rovere cognac			
RD5T	Rovere Dorian			
RG9L	Rovere gesso			
RS4B	Royal oak			
RS8X	Rosa			
RW3Q	Rovere white			
• S				
SP7L	Specchio			
ST6P	Stop sol			

Nomi colore
Colour names

• A	Alluminio	AL1A	Nero Step	NS3Q
Alluminio spazzolato	AS7H	Noce brina	NB5T	
Arancia	Z15L	Nox	0903	
Arancio	Z02K	• O		
Arancio Runner	Z75N	Oliva	LV5T	
Argento	AR3T	Opale	Z85V	
Azzurro	X31H	Oran	OR1S	
• B		• P		
Beige	X28D	Panna	Y33R	
Beige Runner	Z76R	Papaya	PP7H	
Bianco	0025	Papirus	0403	
Bianco	BN7A	Porpora	Z87B	
Bianco	Z01B	• R		
Bianco candido	Z20B	Riso	Z66H	
Bianco Luna	K28F	Rosa	RS8X	
Bianco Nice	K38R	Rosso Luna	K30N	
Bianco Step	K32W	Rovere cognac	RC3Q	
Bianco opaco	BI7A	Rovere Dorian	RD5T	
Blu	X32M	Rovere gesso	RG9L	
Blu pervinca	Z16R	Rovere white	RW3Q	
Blu petrolio	Z70R	Royal oak	RS4B	
Blu Runner	Z77U	• S		
Blue	BL6R	Sabbia Luna	K29K	
• C		Sabbia Nice	K39U	
Cadaques	CQ3Q	Senape	Z79Y	
Carioca	0503	Smoke	0704	
Cemento artico	CA7A	Specchio	SP7L	
Champagne spazzolato	CS4B	Steel	0706	
• D		Stop sol	ST6P	
Desert	Z81G	• T		
Domy	Z83P	Tabacco	Z68Q	
Dorian	Z80B	Tela	0021	
Duna	Z67M	Titanio	Z82L	
• E		Titan grey	TG7H	
Elephant	Z64X	Trasparente	BT4R	
• F		Trasparente	TR9M	
Fiordaliso	Z62R	Trasparente fumè	FT8P	
Fucsia	Z17W	Travertino	Z41G	
• G		• V		
Giallo	X29G	Verde	VE5R	
Grey	0601	Verde eden	Z35F	
Greystone	0604	Vinaccia	Z69T	
Grigio	X22K	Viola	Z14G	
Grigio Dorian	GL4R	• Z		
Grigio medio	Z71U	Zafferano	Z84S	
Grigio oliva	0031	Zinc	0402	
Grigio polvere	Z86Y			
Grigio Runner	Z78X			
Grigio scuro Luna	K31T			
Grigio titanio	GZ8T			
• L				
Lime	X27A			
Limo	Z21R			
Limone	Z13K			
• M				
Miele	ML4B			
• N				
Nero Nice	K40X			
Nero spazzolato	K40X			

Compilazione degli ordini con "TGeo - METRON4 - MULTISTANZA"

Compilation of orders with "TGeo - METRON4 - MULTI-ROOM"

Utilizzare il Colombini Software System permette di:

- Generare preventivi e disegni chiari e corretti.
- Disegnare un'ambientazione reale della composizione.
- Progettare rapidamente un appartamento con tutte le collezioni del Gruppo Colombini.
- Creare progetti che sanno emozionare.
- Ridurre i tempi per lo sviluppo e invio ordini alla Colombini S.p.A.
- Utilizzare lo stesso programma impiegato in Colombini S.p.A.
- Spedire gli ordini tramite Internet garantendone la tracciabilità.
- Disporre dei listini elettronici aggiornati in tempo reale.
- Organizzare in modo flessibile e personalizzato i propri progetti.

Le immagini e i prezzi hanno valore puramente illustrativo.

With the Colombini Software System you can:

- Generate clear, accurate cost estimates and drawings.
- Draw a real rendering of the composition.
- Quickly design an apartment with all the Colombini Group collections.
- Create exciting designs.
- Cut times for developing orders and dispatching them to Colombini S.p.A.
- Use the same programme as Colombini S.p.A. itself.
- Send orders by Internet, with traceability ensured.
- Access electronic price-lists updated in real time.
- Organise your projects in a flexible way, customised to your needs.

Illustrations and prices are purely guidelines.

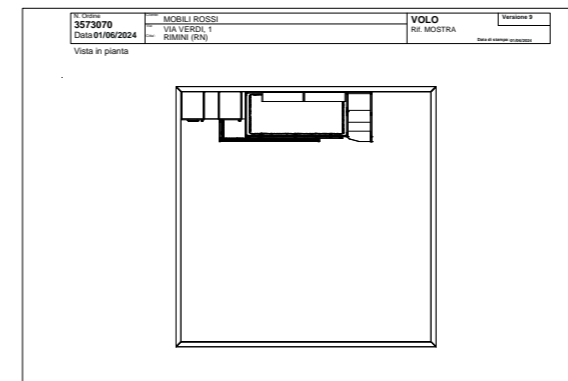
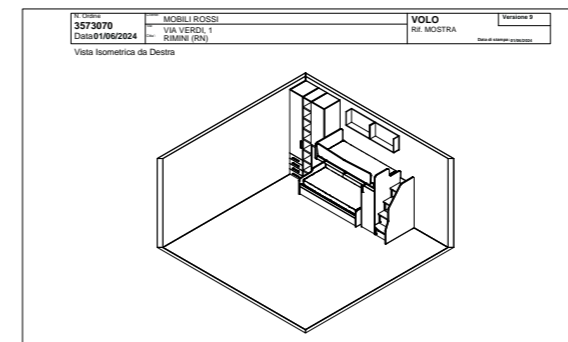
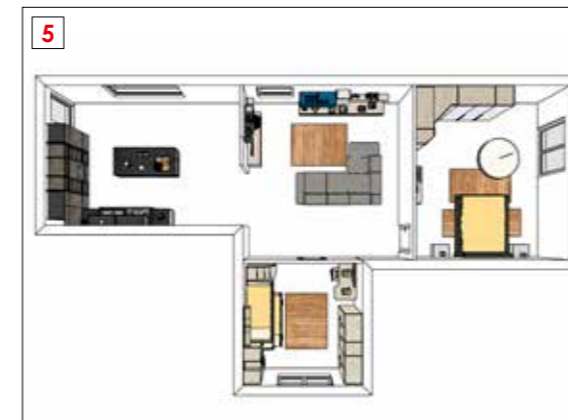
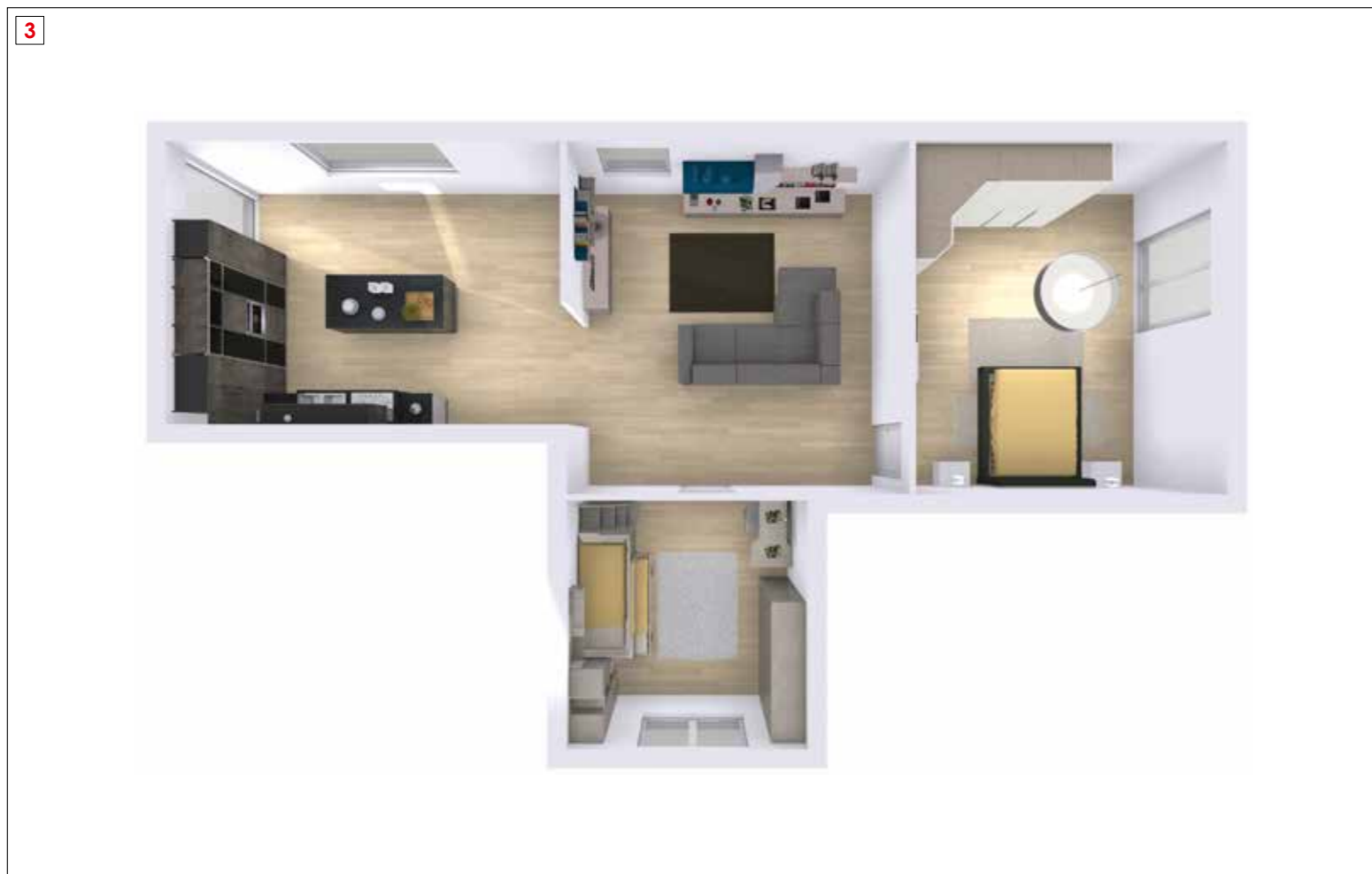

Ordine 6984405	TGeo	Data 01/06/2024
Data Richiesta	RIFERIMENTO ORDINE MOISTRA	
Cliente: MOBILI ROSSI VIA VERDI,1 RIMINI	Destinazione Merce MOBILI ROSSI VIA VERDI,1 RIMINI	
Agente	Tipo Ordine	
Venditore	Info Pagamento	

Note Testata

Configurazione di Testata

MODELLO	VOLO V4
COLORE CASSA (TA)	RW30 - RW/WHITE
COLORE FIANCHI (TA)	NB5T - NOCE BRINA
COLORE FACCIATA (TA)	NB5T - NOCE BRINA
TIPO MANIGLIA (TA)	G28F - PULL1
FINITURA MANIGLIE (TA)	NB5T - NOCE BRINA
TIPO FACCIATA VOLO (TA)	ANTA PANNELLO
COLORE FINITURE LETTI (TA)	NB5T - NOCE BRINA
COLORE MENSOLE/PIANI SAGOMATI	NB5T - NOCE BRINA
COLORE PANNELLO (TA)	NB5T - NOCE BRINA

Pos	Codice	Descrizione	Qta	Prezzo Unitario	Prezzo Totale
1	VF0108P	ARMADIO P56,3 H257,6 L45 -SX - SINISTRO FIANCO INIZIALE C/RALLENTATORI CASSETTI SJ SPESSORE RIPIANO (T) RIPIANO SP.35	1	506	506
2	VF0191S	ARMADIO P56,3 H257,6 L30 GIOR. FIANCO CENTRALE COLORE FIANCHI (TA) RW30 - RW/WHITE SPESSORE RIPIANO (T) RIPIANO SP.35	1	340	340
3	VF0404A	FIANCO SOST.PER VANO 129,6 -SX - SINISTRO	1	85	85

- 1 Creazione ambiente "Metron4"
Creating a "Metron4" room
- 2 Inserimento progetti nell'ambiente creato "Metron4"
Loading projects into the "Metron4" room created
- 3 Vista finale dell'appartamento "Metron4"
"Metron4" apartment final view

- 4 Impaginazione progetto completo "T-Print"
Complete "T-Print" project page layout
- 5 Rendering pianta "T-Rend"
"T-Rend" ground plan rendering
- 6 Rendering composizione "T-Rend"
"T-Rend" composition rendering

CARATTERISTICHE
CHARACTERISTIC

Colori, finiture Colors, finishes	pag. 10
Tessuti, similpelli e microfibre Fabrics, faux leather and microfibers	pag. 12
Colori (non standard) per sedute Colours (not standard) for seats	pag. 14
Colori ruote Wheel colours	pag. 16
Strutture a spalla per Armadi Modular structure for Wardrobes	pag. 18
Strutture per Armadi con ante scorrevoli Structure for Wardrobes with sliding doors	pag. 20
Strutture ad elementi per Componibili a terra/in appoggio Element structures for floor/support Modular units	pag. 22
Strutture ad elementi per Componibili sospesi e Pensili Element structures for Suspended modular units and Hanging units	pag. 24
Facciate VOLO VOLO fronts	pag. 26
Ante WINDOW WINDOW doors	pag. 28
Ante scorrevoli Sliding doors	pag. 30
Lavorazioni particolari Special processes	pag. 32



Rovere white
RW3Q

(A) (★)



Noce brina
NB5T

(A) (★)

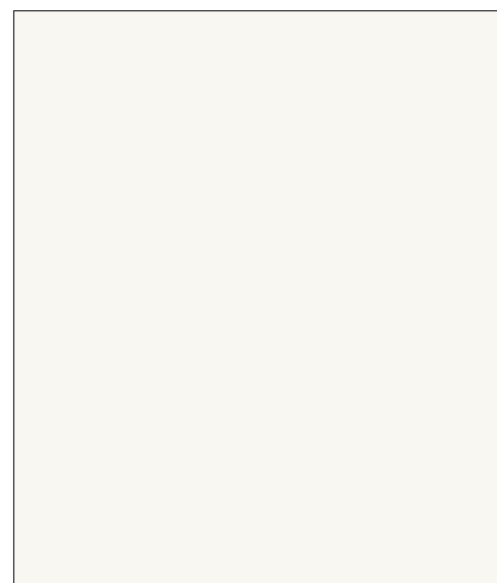

Bianco opaco
BI7A

(A)

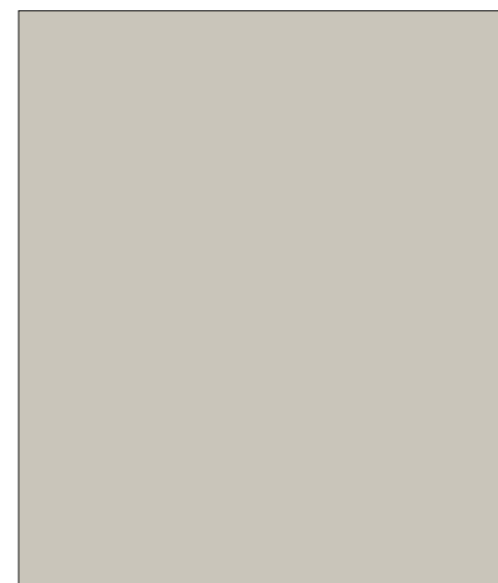

Grigio Dorian
GL4R

(A)



Cemento artico
CA7A

(B) (★)



Rovere gesso
RG9L

(B) (★)



Royal oak
RS4B

(B) (★)



Rovere cognac
RC3Q

(B) (★)

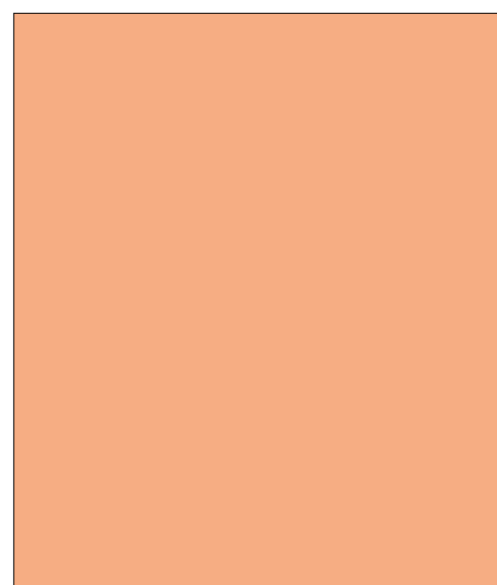

Papaya
PP7H

(B)

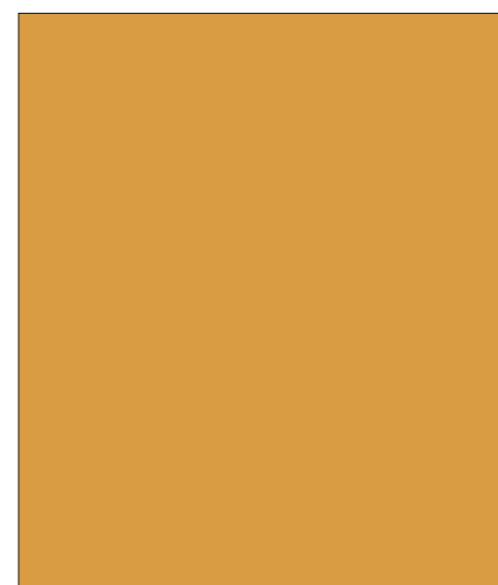

Miele
ML4B

(B)



Oliva
LV5T

(B)

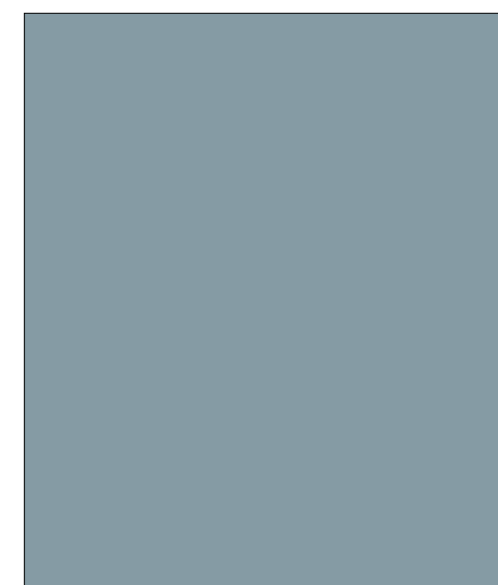

Cadaques
CQ3Q

(B)

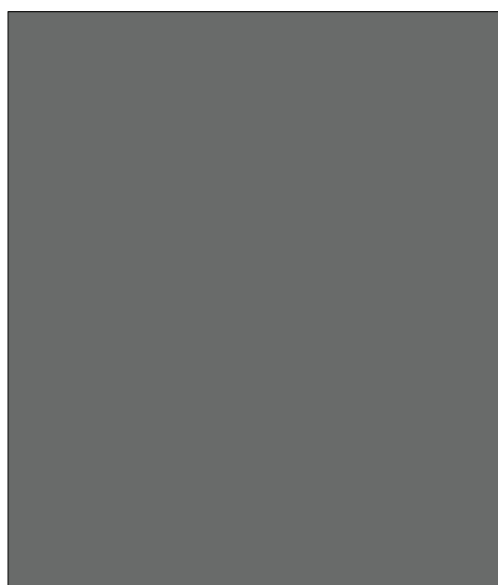

Grigio titanio
GZ8T

(B)

- (A) **Finiture in fascia di prezzo A**
Finishes in price range A
- (B) **Finiture in fascia di prezzo B**
Finishes in price range B
- (★) **Finiture con effetto materico**
Finishes with textured effect

Tessuti, similpelli e microfibre

Fabrics, faux leather and microfibers

Rivestimento
Covering

TESSUTO
FABRIC
JENNY
RV24JN

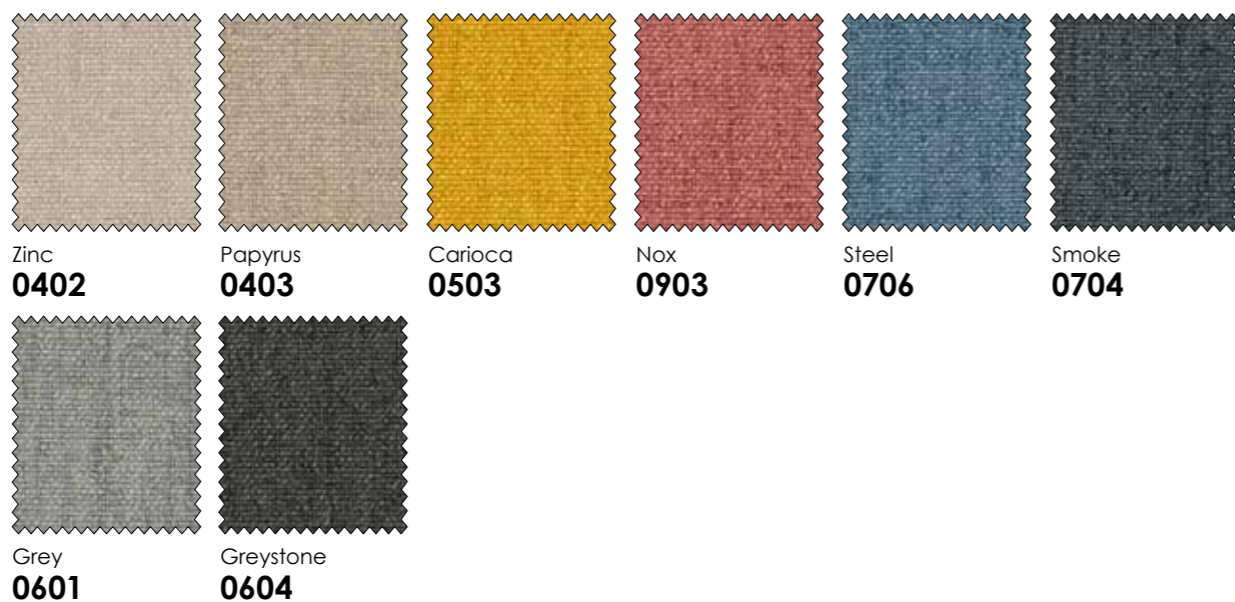

Idrorepellente antimacchia. Grazie a tale trattamento, i liquidi o le sostanze che accidentalmente possono cadere sul rivestimento, non penetrano nel tessuto e non vengono assorbiti dalla gomma del cuscino. Nel caso si versi accidentalmente una soluzione acquosa (acqua, vino, caffè, bibite, ecc.) è sufficiente asciugare con un panno asciutto o carta assorbente. Nel caso in cui il liquido sia rimasto a lungo sul tessuto o abbia subito una eccessiva pressione, dopo aver asciugato, sarà necessario strofinare leggermente con una spugna umida non abrasiva. Nei casi più gravi si potrà utilizzare sapone neutro, successivamente da risciacquare.

Water-repellent stain. Thanks to this treatment, liquids or substances that may accidentally fall on the coating, will not penetrate into the fabric and will not be absorbed by the rubber in the cushion. In case you accidentally spill a watery solution (water, wine, coffee, soft drinks, etc.) it is enough to dry it with a dry cloth or paper towels. In the case the substance remains on the fabric for a prolonged amount of time or has suffered excessive pressure, after having been dried, you will need to rub gently with a damp non-abrasive sponge. In severe cases, you can use mild soap, subsequently rinse afterwards.

Ignifugo CLASSE 1 (UNO)
Fireproof 1 CLASS (ONE)

Consegna 4 settimane circa dal ricevimento dell'ordine.
Delivery approximately 4 weeks from order receipt.

Il rivestimento, al momento del disimballo o in seguito ad un utilizzo anomalo, potrebbe presentare delle vistose macchie o righe dovute allo schiacciamento delle fibre. Utilizzare una spazzola con setole morbide per riportarlo alla naturalezza originaria.
At the time of unpacking or following incorrect use, the covering may display visible blotches or lines caused by crushed fibres. Use a brush with soft bristles to return the cover to its original appearance.

TESSUTO FABRIC	Composizione: Composition:	Peso: Weight:	Martindale: Martindale:	Indicazioni per il lavaggio: Washing instructions:	
TESSUTO FABRIC JENNY - RV24JN	poliestere polyester	100%	375 gr/m ²	60,000	
TESSUTO FABRIC ECOCHIC	poliestere polyester	100%	350 gr/m ²	> 100,000	
SIMILPELLE FAUX LEATHER ECOCHIC	poliestere polyester	100%	190 gr/m ²	-	 Pulire con panno morbido ed umido, delicatamente. Non usare abrasivi, detersivi chimici o sgrassatori. L'utilizzo di questi prodotti rovinerebbe irrimediabilmente il rivestimento. Clean gently with damp, soft cloth. Do not use abrasive and degreasing products or chemical detergents, which may ruin irremediably the upholstery.
MICROFIBRA MICROFIBRE ECOCHIC	poliestere polyester	100%	350 ± 5% gr/m ²	40,000	 Infiammabilità - L'articolo è conforme alle seguenti norme: Fire resistance - This product has been successfully tested according to the following methods: · Classe 1 IM (UNI 9175) · EN 1021-1:2006 & EN 1021-2:2006 · BS 5852 PART 0 & 1:1979 · CRIB 5 BS 5852:2006

I colori sono soggetti a cambiamenti di tono tra bagni diversi. Il produttore si riserva di modificare, in qualsiasi momento e senza preavviso, le specifiche del prodotto.
Colors may vary from lot to lot. The producer reserves the right to modify, at any moment and without notice, the technical specifications of their products.

Questi valori sono dati a titolo indicativo ed in buona fede e non possono essere considerati in alcun caso vincolanti.
These indications are merely guidelines and are provided in good faith; they may not be considered binding in any circumstance.

Rivestimento
Covering

TESSUTO
FABRIC
ECOCHIC

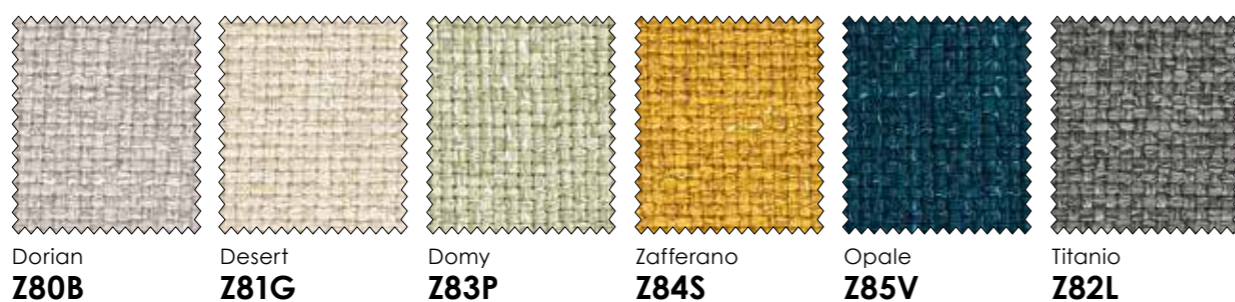

SIMILPELLE
FAUX LEATHER
ECOCHIC

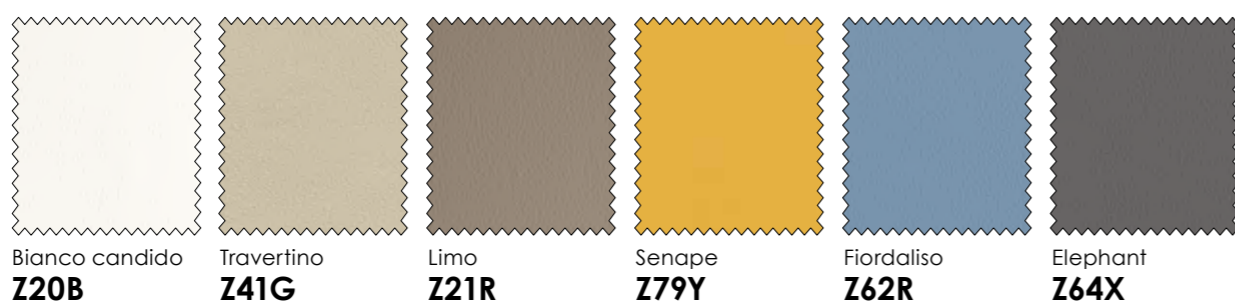

MICROFIBRA
MICROFIBRE
ECOCHIC



Cuciture a contrasto letti KISS

KISS beds contrasting seams

Tessuto ECOCHIC: Fabric ECOCHIC:	Opzioni colore cordoncino: Cord colour options:	Similpelle ECOCHIC: Faux leather ECOCHIC:	Opzioni colore cordoncino: Cord colour options:	Opzioni colore cordoncino: Cord colour options:
Z80B Dorian	→ Z82L Titanio	Z20B Bianco candido	Z20B Bianco cand.	Z62R Fiordaliso
Z81G Desert	→ Z82L Titanio		Z41G Travertino	Z64X Elephant
Z83P Domy	→ Z81G Desert		Z64X Elephant	Z20B Bianco cand.
Z84S Zafferano	→ Z81G Desert	Z41G Travertino	Z41G Travertino	Z64X Elephant
Z85V Opale	→ Z81G Desert		Z20B Bianco cand.	Z20B Bianco cand.
Z82L Titanio	→ Z81G Desert		Z21R Limo	Z64X Elephant
		Z21R Limo	Z21R Limo	Z79Y Senape
			Z41G Travertino	Z64X Elephant

Colori (non standard) per sedute

Colours (not standard) for seats

1 POLIPROPILENE TERMOFORMATO

THERMOFORMED POLYPROPYLENE

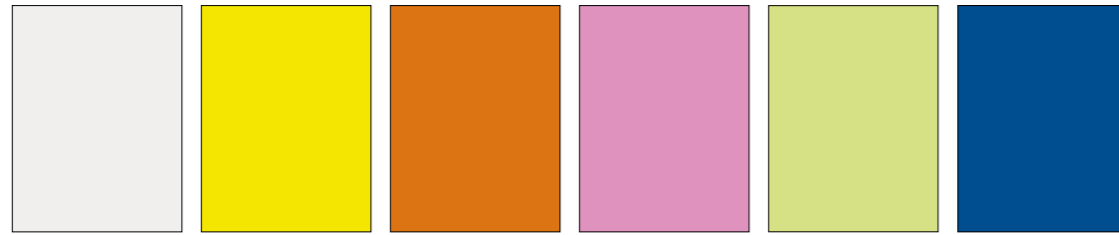

Panna **Y33R** Limone **Z13K** Arancia **Z15L** Viola **Z14G** Verde eden **Z35F** Blu pervinca **Z16R**

2 PLASTICA ATOSSICA

NON-TOXIC PLASTIC

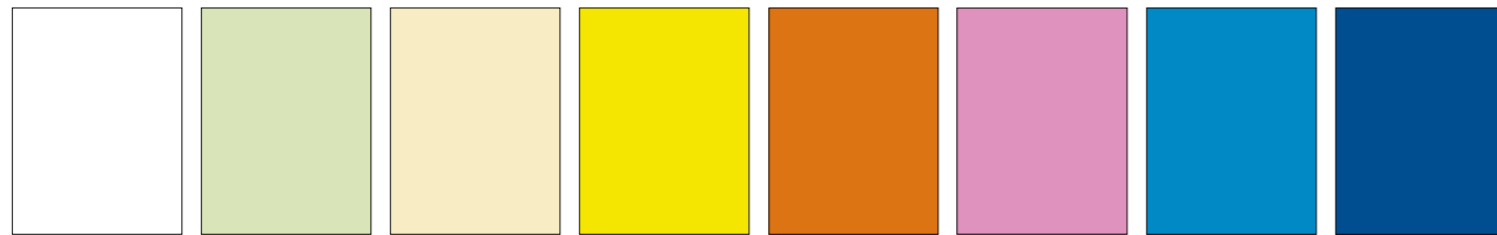

Bianco **Z01B** Lime **X27A** Beige **X28D** Giallo **X29G** Arancio **Z02K** Fucsia **Z17W** Azzurro **X31H** Blu **X32M**

3 POLIPROPILENE

POLYPROPYLENE



Bianco Luna **K28F** Sabbia Luna **K29K** Rosso Luna **K30N** Grigio scuro Luna **K31T**

TESSUTO (seduta imbottita)

FABRIC (cushion)

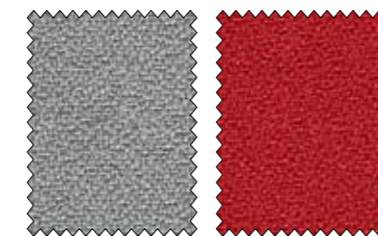

Grigio polvere **Z86Y** Porpora **Z87B**

4 POLIPROPILENE TERMOFORMATO

THERMOFORMED POLYPROPYLENE

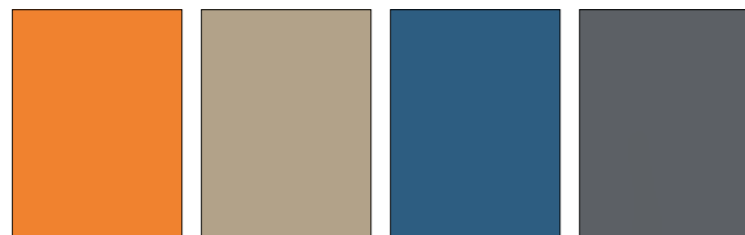

Arancio Runner **Z75N** Beige Runner **Z76R** Blu Runner **Z77U** Grigio Runner **Z78X**

1

KART

KART
Con ruote e girevole
With wheels and swivel

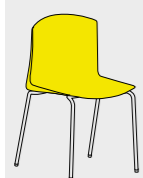

TRAK
Con ruote e girevole
With wheels and swivel



2

PUNTO
Con ruote e girevole
With wheels and swivel

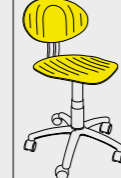

3

LUNA

LUNA
Con seduta imbottita
With cushion



LUNA
Con ruote
With wheels



LUNA
Con seduta imbottita e ruote
With cushion and wheels



4

RUNNER
Con ruote e girevole
With wheels and swivel

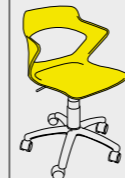

5

GIROTONDO
Con ruote e girevole
With wheels and swivel

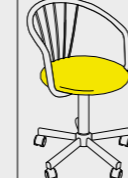

6

ARIES

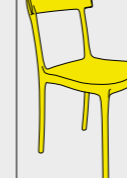

7

STEP

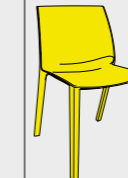

8

NICE



9

LIPSIA



Idrorepellente antimacchia.
Water-repellent stain.

5 TESSUTO

FABRIC



Grigio **X22K**

7 POLIPROPILENE

POLYPROPYLENE

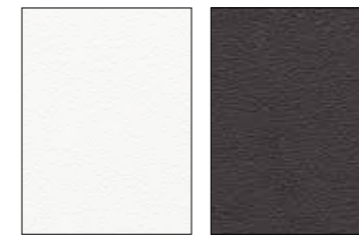

Bianco Step **K32W** Nero Step **K33Z**

9 TESSUTO

FABRIC **RITUAL - RV26RT**



Bianco **0025** Tela **0021** Grigio oliva **0031**

6 POLIPROPILENE

POLYPROPYLENE



Bianco ottico **-** Tortora **-** Nero **-**

8 POLIPROPILENE

POLYPROPYLENE

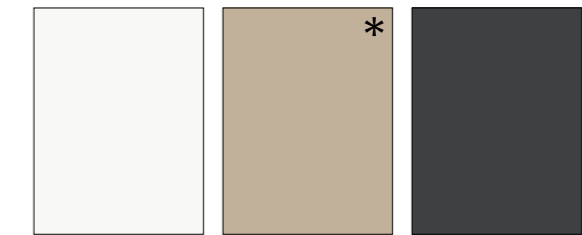

Bianco Nice **K38R** Sabbia Nice **K39U** Nero Nice **K40X**

* **Ordinando il Sabbia Nice la sedia risulterà bicolore, con seduta e schienale colore bianco e struttura colore sabbia.**
By ordering Sabbia Nice the chair will be two-coloured, with a white seat and back and a sand-coloured structure.

Colori ruote

Wheel colours

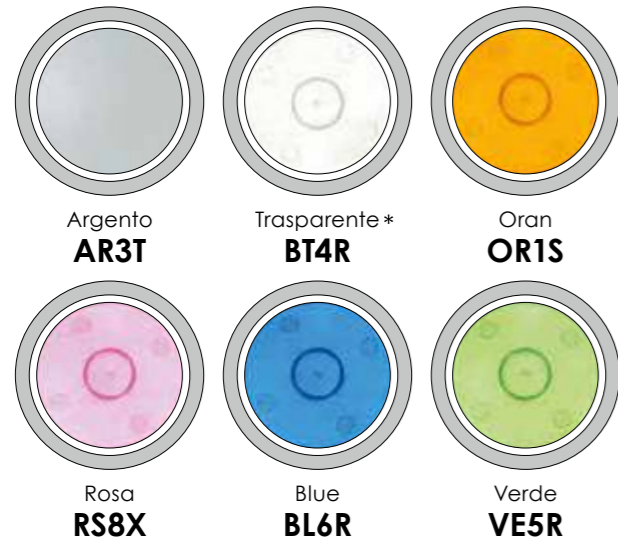

- 1** **Ruota piccola Ø 6 (SENZA FRENO)**
Viene applicata a: cassetiera con ruote e porta PC.
Ruota grande Ø 12
Viene applicata ai letti START e Giroletto metallico.
- Small wheel Ø 6 (WITHOUT BRAKE)
Is applied to: chest of drawers with wheels and PC holder.
Large wheel Ø 12
Is applied to START bed and bed with metal frame.

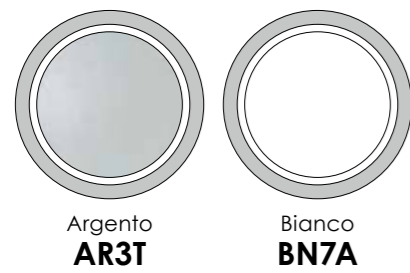
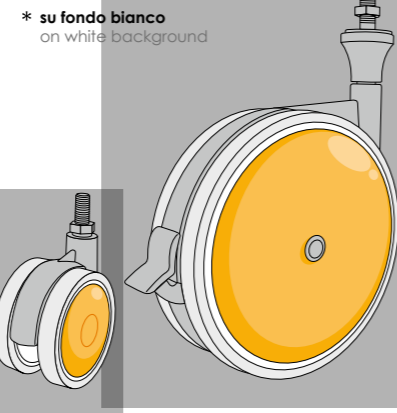

- 2** **Ruota piccola Ø 6 (CON FRENO)**
Viene applicata a: cassetiera con ruote.
- Small wheel Ø 6 (WITH BRAKE)
Is applied to: chest of drawers with wheels.

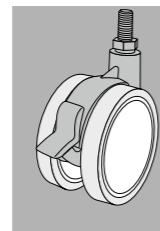

Strutture a spalla per Armadi

Modular structure for Wardrobes

Rovere white

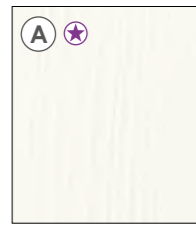

Rovere white
RW3Q

Finitura unica per tutti i componenti in pannello presenti a listino non evidenziati con il colore Finiture GRUPPO 1 e/o Finiture GRUPPO 2.

Unique finish for all the panel components shown in the pricelist not highlighted with the color finishes GROUP 1 and/or finishes GROUP 2.

Finiture GRUPPO 1
GROUP 1 finishes

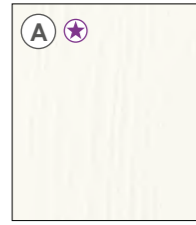

Rovere white
RW3Q

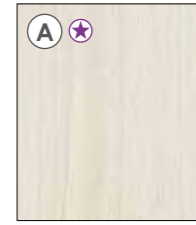

Noce brina
NB5T



Bianco opaco
B17A

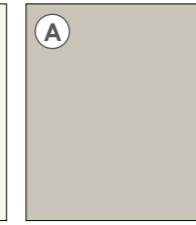

Grigio Dorian
GL4R

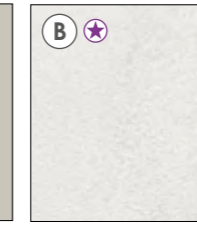

Cemento artico
CA7A

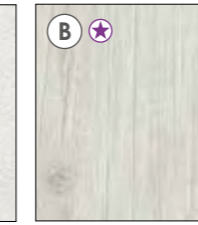

Rovere gesso
RG9L

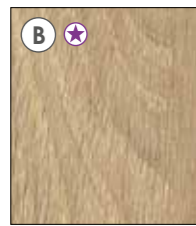

Royal oak
RS4B

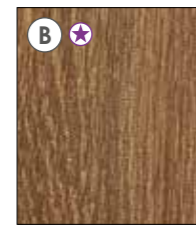

Rovere cognac
RC3Q

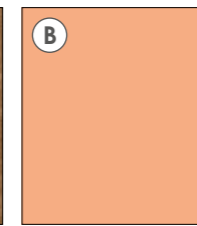

Papaya
PP7H

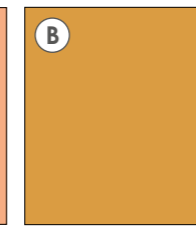

Miele
ML4B

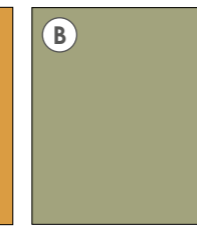

Oliva
LV5T

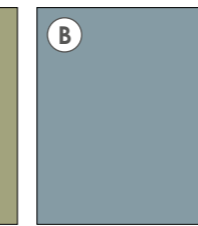

Cadaques
CQ3Q

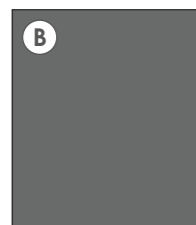

Grigio titanio
GZ8T

- A** Finiture in fascia di prezzo A
Finishes in price range A
- B** Finiture in fascia di prezzo B
Finishes in price range B
- ☆** Finiture con effetto materico
Finishes with textured effect

Caratteristiche

Characteristics

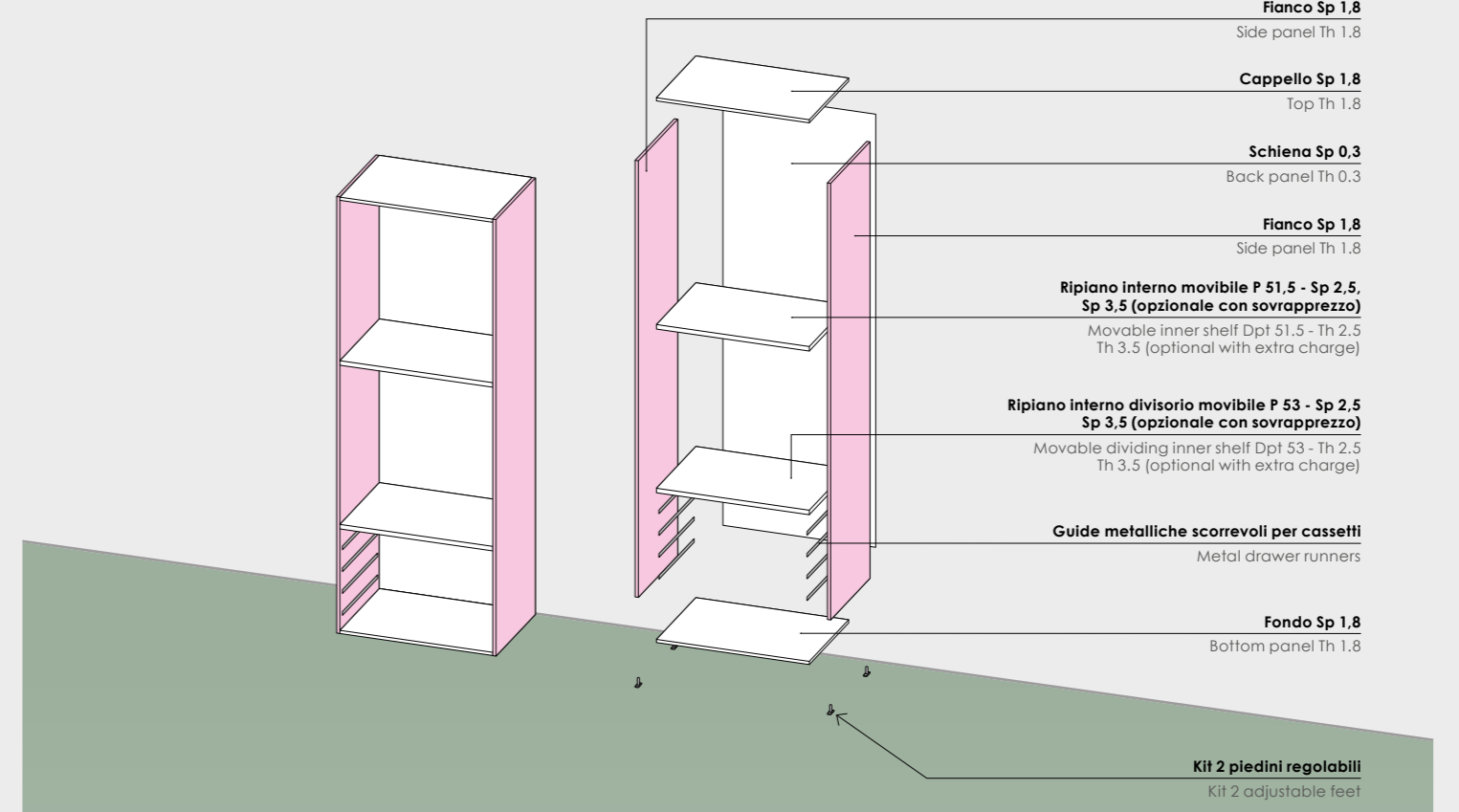

- Importante:**
- Fianco centrale, cappello, fondo e ripiani in finitura Rovere white (RW3Q), schiena in finitura tinta unita abbinabile.
 - Sono strutture posizionabili solo a terra.
 - Sono dotate di piedini regolabili.
 - I fianchi sono predisposti per il montaggio della ferramenta di ante, cassetti, ripiani.
- Dotazione interna:**
- Gli elementi a giorno sono dotati di ripiani ogni 32 cm.
 - Negli armadi in corrispondenza di ante H 224 e H 256 sono presenti 1 ripiano interno e 2 tubi appendi abiti.
 - Negli armadi con ante H 96, 128, 160 e 192 è presente un tubo appendiabiti.

- Important:**
- Middle panel, top, bottom panel and shelves in Rovere white (RW3Q) finish, back in matching solid color finish.
 - These structures can only be placed on the ground.
 - They are fitted with adjustable feet.
 - The side panels are prefitted to take the hardware of doors, drawers, shelves.
- Element equipment:**
- Open elements are fitted with shelves every 32 cm.
 - In the wardrobes in correspondence of doors Ht 224 and Ht 256 there are 1 inner shelf and 2 clothes hanging bars.
 - In the wardrobes in correspondence of doors Ht 96, 128, 160, and 192 there is 1 clothes hanging bar.

Utilizzata per:
ARMADI
L 30 - 45 - 60 - 90 (fianco iniziale compreso)
P 56,3
H 225,6 - 257,6 (piedini H 0,7 compresi)

Used for:
WARDROBES
W 30 - 45 - 60 - 90 (starting side panel included)
Dpt 56.3
Ht 225.6 - 257.6 (Ht 0.7 feet included)

Esempio composizione

Example of composition

- Ogni composizione deve essere completata dal fianco finale.
 - In composizioni con altezze diverse, ogni elemento dovrà essere completato dal fianco finale.
- The compositions must be completed with an end side panel.
• In compositions with different heights, each element must be completed by the end side panel.

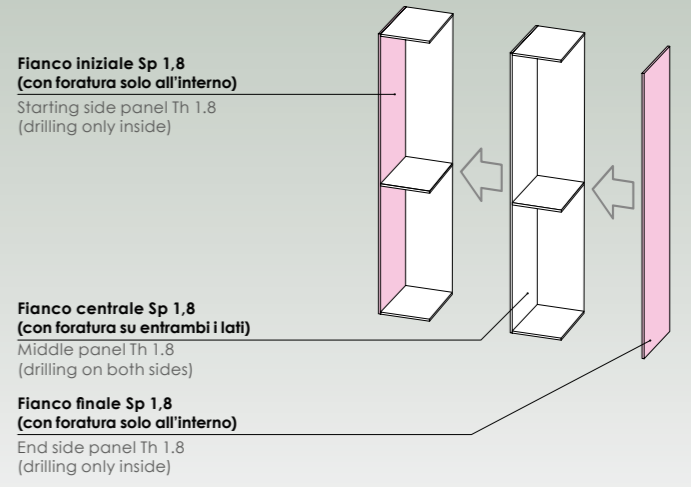

Strutture per Armadi con ante scorrevoli

Structure for Wardrobes with sliding doors

Rovere white

RW3Q

A ☆

Finitura unica per tutti i componenti in pannello presenti a listino non evidenziati con il colore Finiture GRUPPO 1 e/o Finiture GRUPPO 2.

Unique finish for all the panel components shown in the pricelist not highlighted with the color finishes GROUP 1 and/or finishes GROUP 2.

Finiture GRUPPO 1
GROUP 1 finishes

A ☆ Rovere white RW3Q	A ☆ Noce brina NB5T	A Bianco opaco B17A	A Grigio Dorian GL4R	B ☆ Cemento artico CA7A	B ☆ Rovere gesso RG9L
B ☆ Royal oak RS4B	B ☆ Rovere cognac RC3Q	B Papaya PP7H	B Miele ML4B	B Oliva LV5T	B Cadaques CQ3Q
B Grigio titanio GZ8T					

Caratteristiche
Characteristics

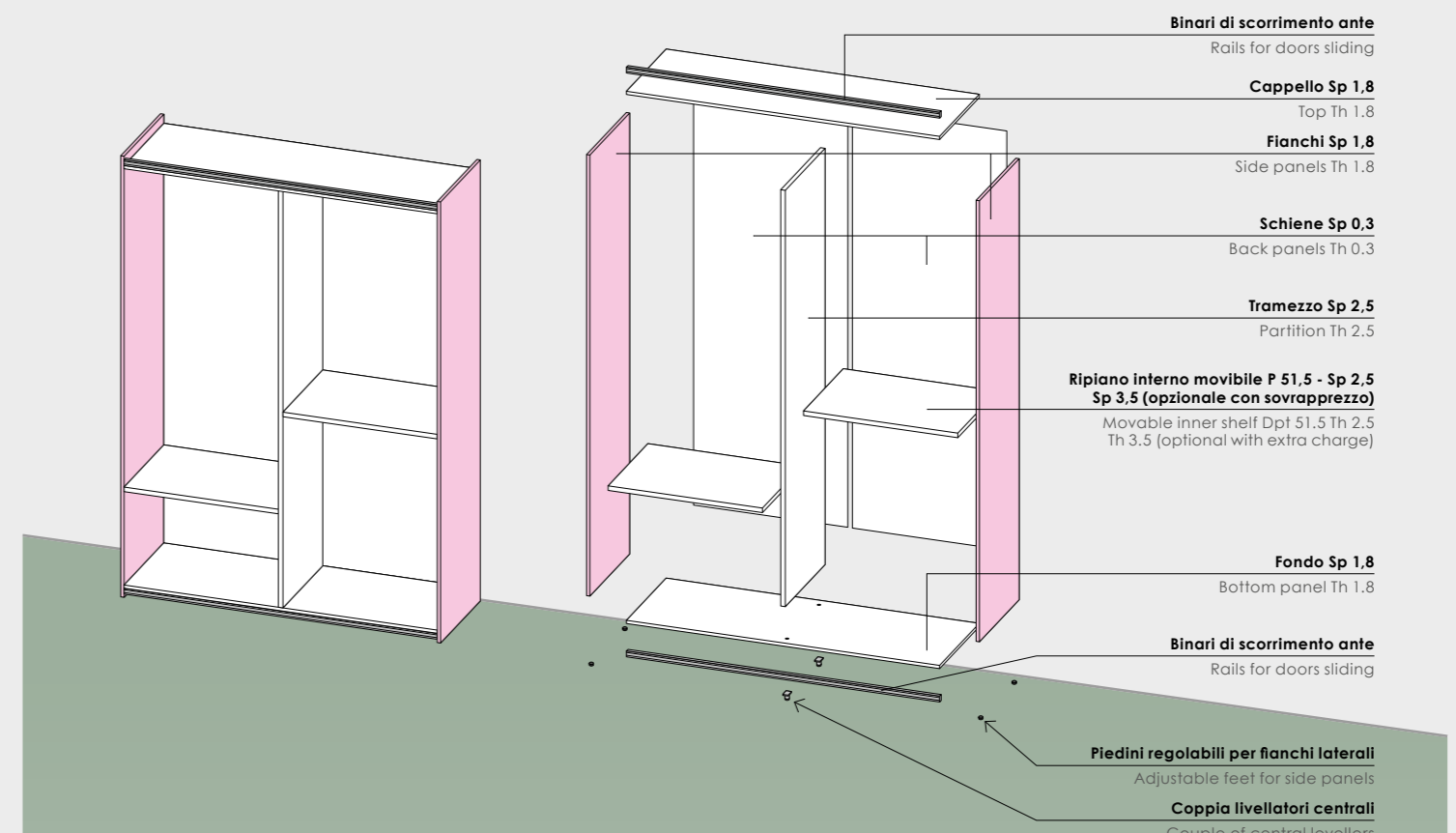

- Importante:**
- Fianco centrale, cappello, fondo e ripiani in finitura **Rovere white (RW3Q)**, schiene in finitura tinta unita abbinabile.
 - Sono strutture posizionabili solo a terra.
 - Sono dotate di piedini regolabili.
 - I fianchi sono predisposti per il montaggio della ferramenta dei ripiani.
- Dotazione interna:**
- Sono dotate di 2 tubi appendiabiti e 1 ripiano per ogni vano.

- Important:**
- Middle panel, top, bottom panel and shelves in **Rovere white (RW3Q)** finish, back in matching solid color finish.
 - These structures can only be positioned on the ground.
 - Equipped with adjustable feet.
 - Side panels are prefitted to take the hardware of shelves.
- Element equipment:**
- Fitted with 2 clothes hanging bars and 1 shelf for each door space.

Nota bene:
Per il montaggio occorre considerare uno spazio aggiuntivo in larghezza di 4 cm e in altezza di 8 cm (per il corretto scorrimento delle ante in nicchia servono almeno 4 cm in altezza).

Please note:
For assembly, at least an extra 4 cm in width and at least an extra 8 cm in height is required (for the correct sliding of the doors in the niche you need at least 4 cm in height).

Utilizzata per:
ARMADI
L 146,7 - 178,7 - 219,5 - 267,5
P 61,5
H 225,3 - 257,3 (piedini H 0,3 compresi)

Used for:
WARDROBES
W 146.7 - 178.7 - 219.5 - 267.5
Dpt 61.5
Ht 225.3 - 257.3 (Ht 0.3 feet included)

Schema di apertura ante scorrevoli
Opening diagram for wardrobes sliding doors

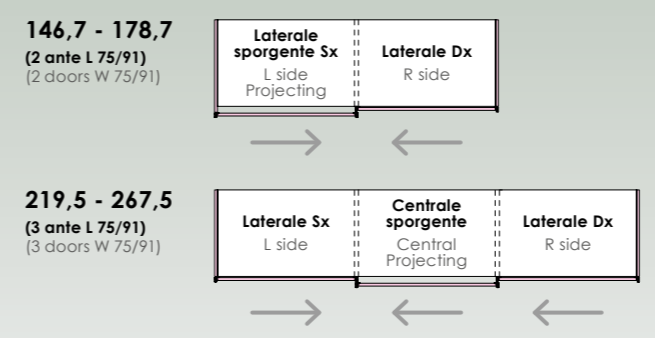

Indicare anta sporgente Dx o Sx
Indicate whether projecting door is R or L

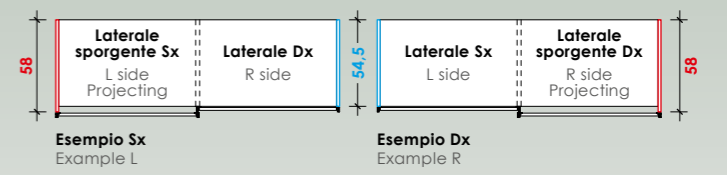

Al momento dell'ordine di armadi a 2 ante, è indispensabile specificare se l'anta sporgente è Dx o Sx. Il fianco accanto all'anta sporgente è profondo 58 cm, mentre il fianco accanto all'anta non sporgente è profondo 54,5 cm.

When ordering wardrobes with 2 doors, it is essential to specify whether the projecting door is R or L. The side panel next to the projecting door has depth 58 cm, while the side panel next to the non-projecting door is 54.5 cm deep.

Non è possibile invertire il verso di apertura.
Door opening direction cannot be reversed.

A Finiture in fascia di prezzo A
Finishes in price range A
B Finiture in fascia di prezzo B
Finishes in price range B
☆ Finiture con effetto materico
Finishes with textured effect

Strutture ad elementi per Componibili a terra/in appoggio

Element structures for floor/support Modular units

Rovere white

A ☆

Finitura unica per tutti i componenti in pannello presenti a listino non evidenziati con il colore Finiture GRUPPO 1 e/o Finiture GRUPPO 2.

Unique finish for all the panel components shown in the pricelist not highlighted with the color finishes GROUP 1 and/or finishes GROUP 2.

Rovere white
RW3Q

Finiture GRUPPO 1
GROUP 1 finishes

A ☆

Rovere white
RW3Q

A ☆

Noce brina
NB5T

A

Bianco opaco
B17A

A

Grigio Dorian
GL4R

B ☆

Cemento artico
CA7A

B ☆

Rovere gesso
RG9L

B ☆

Royal oak
RS4B

B ☆

Rovere cognac
RC3Q

B

Papaya
PP7H

B

Miele
ML4B

B

Oliva
LV5T

B

Cadaques
CQ3Q

B

Grigio titanio
GZ8T

Caratteristiche

Characteristics

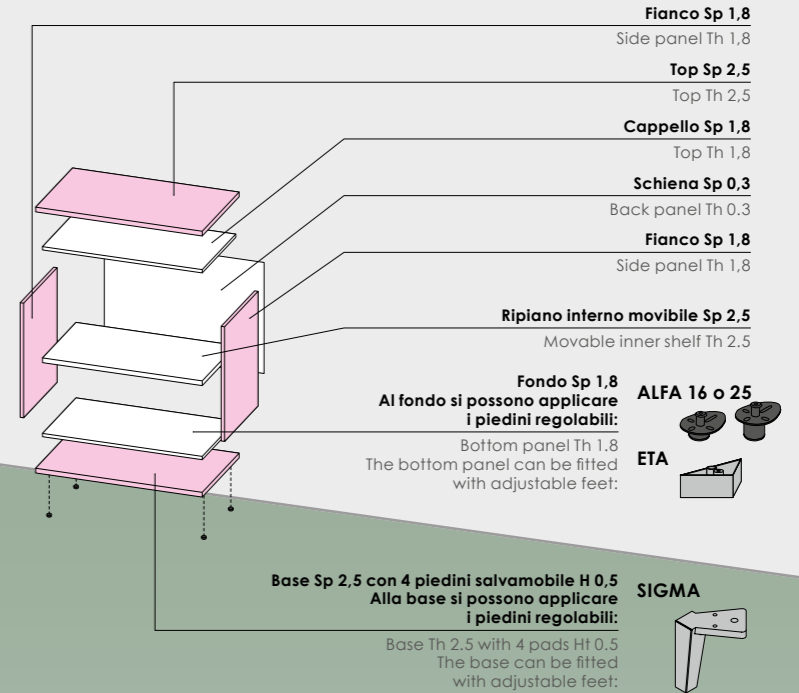

Importante:

- Cappello, fondo e ripiani in finitura Rovere white (RW3Q), schiena in finitura tinta unita abbinabile.
- Sono strutture posizionabili a terra con l'utilizzo di piedi oppure di una base Sp 2,5 dotata di piedini "salva-mobile" H 0,5.
- Ogni struttura è completa di 2 fianchi perfettamente a filo di cappello e fondo. Gli elementi L 120 sono dotati di un divisorio verticale interno Sp 2,5.
- Le strutture possono essere posizionate l'una sull'altra e completate con un top. Composizioni di più elementi possono avere il top e la base interi (L 360 max).
- I fianchi sono predisposti per il montaggio della ferramenta di ante, cassetti e ripiani.
- Vengono forniti montati.

Dotazione interna:

- Tutti gli elementi sono dotati di ripiani interni ogni 32 cm.

Utilizzata per:

COMPONIBILI

L 45 - 60 - 90 H 32 - 64 - 96 - 128 (esclusi top, base, piedi)
L 120 H 32 (esclusi top, base, piedi)
P 45,8

Important:

- Top, bottom panel and shelves in Rovere white (RW3Q) finish, back in matching solid color finish.
- These structures can be positioned on the floor with use feet or base Th 2,5 with feet "save-furniture" Ht 0,5.
- Each structure is complete with 2 sides which finish flush with top and bottom. The W 120 elements are equipped with an internal vertical divider Th 2,5.
- Structures can be positioned one on top of the other and completed with top. A composition of multiple units can share same top and bottom (W 360 max).
- Side panels are prefitted to take the hardware of doors, drawers and shelves.
- Elements are supplied assembled.

Internal equipment:

- All items come with inner shelves every 32 cm.

Used for:

MODULAR UNITS

W 45 - 60 - 90 Ht 32 - 64 - 96 - 128 (top, base and feet not included)
W 120 Ht 32 (top, base and feet not included)
Dpt 45,8

Esempi di componibilità

Examples of compositions

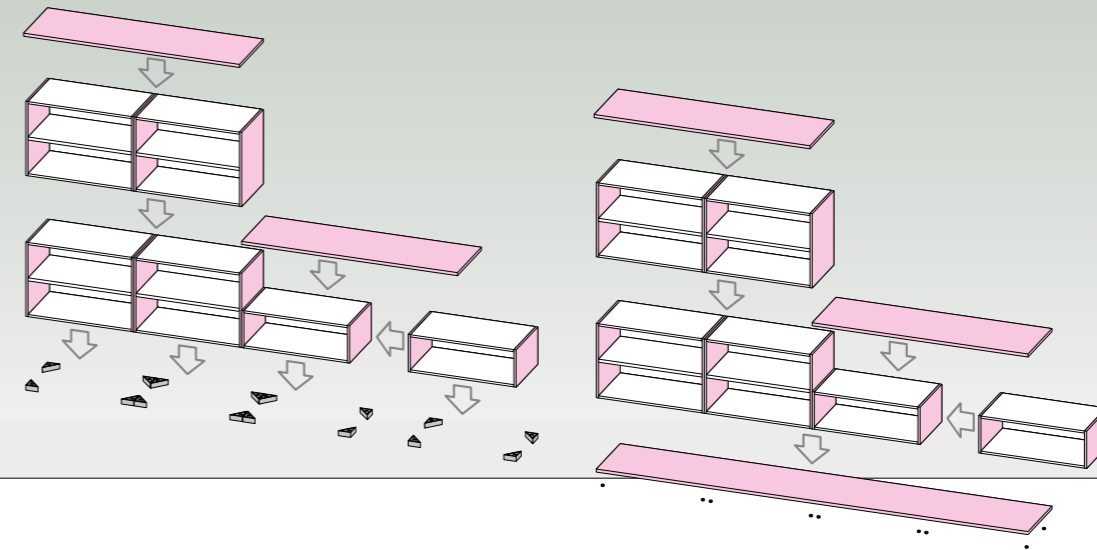

- A Finiture in fascia di prezzo A
Finishes in price range A
- B Finiture in fascia di prezzo B
Finishes in price range B
- ☆ Finiture con effetto materico
Finishes with textured effect

Strutture ad elementi per Componibili sospesi e Pensili

Element structures for Suspended modular units and Hanging units

Rovere white

RW3Q

A ☆

Finitura unica per tutti i componenti in pannello presenti a listino non evidenziati con il colore Finiture GRUPPO 1 e/o Finiture GRUPPO 2.

Unique finish for all the panel components shown in the pricelist not highlighted with the color finishes GROUP 1 and/or finishes GROUP 2.

Finiture GRUPPO 1
GROUP 1 finishes

A ☆	A ☆	A	A	B ☆	B ☆
Rovere white RW3Q	Noce brina NB5T	Bianco opaco B17A	Grigio Dorian GL4R	Cemento artico CA7A	Rovere gesso RG9L
B ☆	B ☆	B	B	B	B
Royal oak RS4B	Rovere cognac RC3Q	Papaya PP7H	Miele ML4B	Oliva LV5T	Cadaques CQ3Q
B					
Grigio titanio GZ8T					

Caratteristiche

Characteristics

Fianco Sp 1,8
Side panel Th 1,8

Top Sp 2,5
Top Th 2,5

Cappello Sp 1,8
Top Th 1,8

Schiena Sp 0,3
Back panel Th 0,3

Fianco Sp 1,8
Side panel Th 1,8

Fondo Sp 1,8
Bottom panel Th 1,8

COMPONIBILE SOSPESO
SUSPENDED MODULAR UNIT

Fianco Sp 1,8
Side panel Th 1,8

Top Sp 2,5 (non obbligatorio)
Top Th 2,5 (not mandatory)

Cappello Sp 1,8
Top Th 1,8

Schiena Sp 0,3
Back panel Th 0,3

Fianco Sp 1,8
Side panel Th 1,8

Fondo Sp 1,8
Bottom panel Th 1,8

PENSILE
HANGING UNIT

101
H min
Ht min

Importante:

- **Componibili sospesi con cappello, fondo e ripiani in finitura Rovere white (RW3Q), schiena in finitura tinta unita abbinabile.**
- **Pensili con ripiani in finitura Rovere white (RW3Q) e schiena in finitura tinta unita abbinabile.**
- **Ogni struttura è completa di 2 fianchi perfettamente a filo di cappello e fondo. Gli elementi L 120 sono dotati di un divisorio verticale interno Sp 2,5 nei componibili sospesi e Sp 1,8 nei pensili.**
- **I fianchi sono predisposti per il montaggio della ferramenta delle ante.**
- **Completare ogni composizione di Componibili sospesi con top. Nei Pensili l'utilizzo del top non è obbligatorio.**
- **Composizioni di più elementi possono avere il top intero (L 360 max).**
- **I Componibili sospesi ed i Pensili sono completi di attaccaglie per fissaggio al muro dotate di antiganciamento. Nei Pensili la ferramenta è di tipo invisibile.**
- **Vengono forniti montati.**
- **Rispondono alla normativa europea 14749 "Requisiti di sicurezza dei mobili contenitori per uso domestico".**

Dotazione interna:

- **Tutti gli elementi sono dotati di ripiani interni ogni 32 cm.**

Utilizzata per:

COMPONIBILI SOSPESI

L 45 - 60 - 90	H 32 - 64 (escluso top)
L 120	H 32 (escluso top)
P 45,8	

PENSILI

L 45 - 60 - 90 - 120	H 32
L 30 - 45 - 60	H 96 - 128
L 30 - 45	H 160
P 32,5	

Importante:

- **Suspended modular units with top, bottom panel and shelves in Rovere white (RW3Q) finish, back in matching solid color finish.**
- **Hanging units with shelves in Rovere white (RW3Q) finish and back in matching solid color finish.**
- **Each structure is complete with 2 sides which finish flush with top and bottom. The W 120 elements are equipped with an internal vertical divider Th 2,5 in the suspended modular units and Th 1,8 in the wall units.**
- **Side panels are prefitting to take the hardware of doors.**
- **Complete every suspended Modular composition with top. The top on the hanging units is not essential. Multiple element compositions can share same top (W 360 max).**
- **The suspended modular units and hanging units come with adjustable brackets with an antirelease device for wall fixing. The hardware in the wall units is invisible type.**
- **Elements are supplied assembled.**
- **They comply with the European standard 14749 "Safety requirements for storage furniture for domestic use".**

Internal equipment:

- **All items come with inner shelves every 32 cm.**

Used for:

SUSPENDED MODULAR UNITS

W 45 - 60 - 90	Ht 32 - 64 (top excluded)
W 120	Ht 32 (top excluded)
Dpt 45,8	

HANGING UNITS

W 45 - 60 - 90 - 120	Ht 32
W 30 - 45 - 60	Ht 96 - 128
W 30 - 45	Ht 160
Dpt 32,5	

A Finiture in fascia di prezzo A
Finishes in price range A

B Finiture in fascia di prezzo B
Finishes in price range B

☆ Finiture con effetto materico
Finishes with textured effect

Finiture GRUPPO 1
GROUP 1 finishes

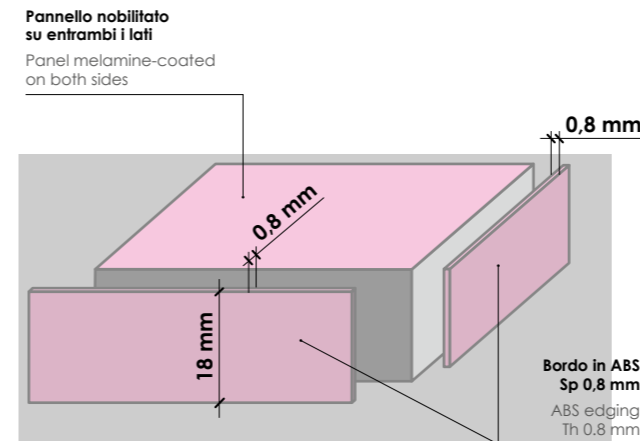
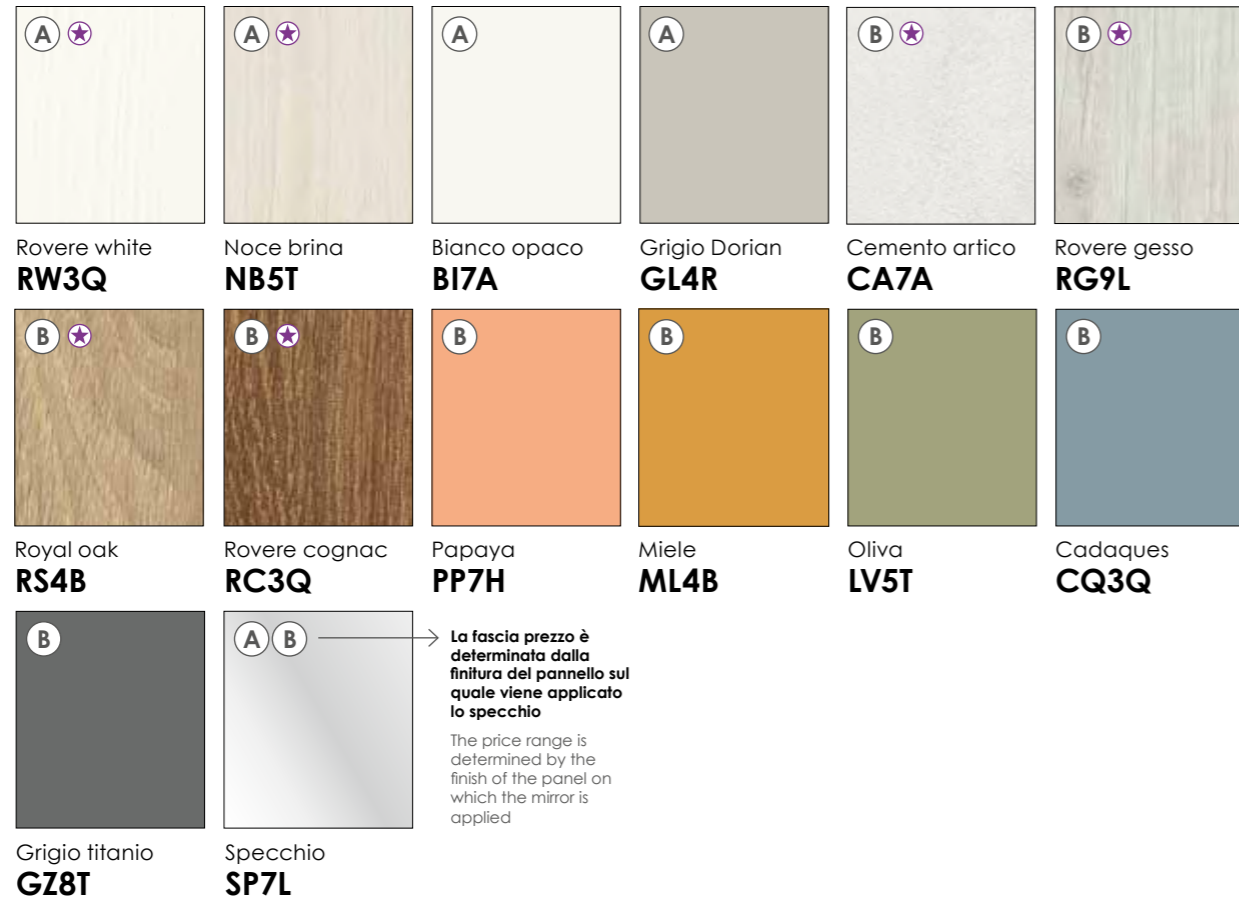

Dimensioni disponibili
Dimensions available

- Ante**
- Sono fornite con preforo per maniglia.
 - Su richiesta possono essere dotate di rallentatori di chiusura (con sovrapprezzo).
 - Riducibili in altezza e in larghezza.

- Doors**
- Supplied with semi-cut hole for handle.
 - Can be fitted with closing retainers on request (with surcharge).
 - Can be reduced in height and width.

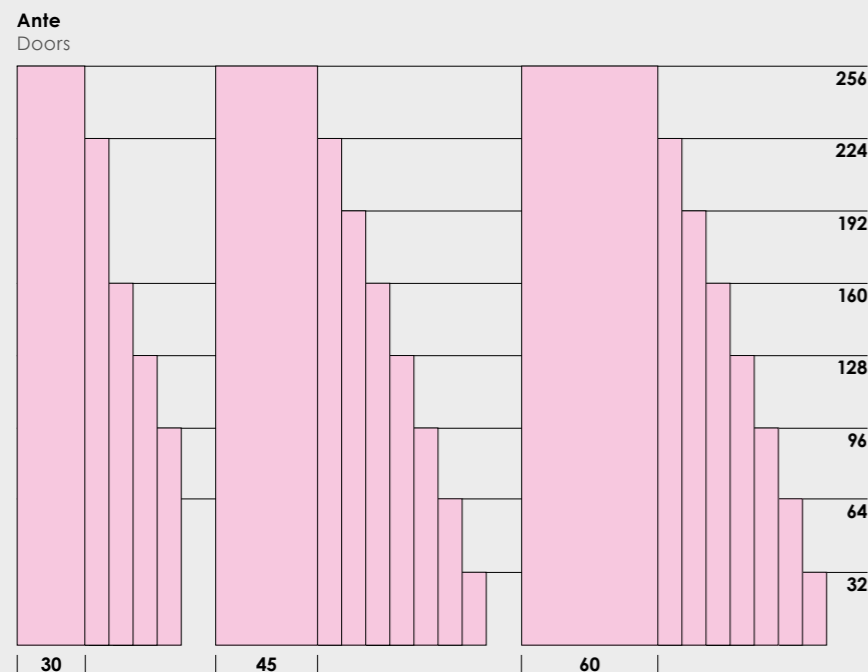

- Ante specchio**
- Specchio Sp 4 mm applicato su pannello in nobilitato Sp 1,8.
 - Sono dotate di pomello SEM.
 - Su richiesta possono essere dotate di rallentatori di chiusura (con sovrapprezzo).
 - Non sono ammesse riduzioni dimensionali.

- Mirror doors**
- Mirror Th 4 mm applied on melamine-coated panel Th 1.8.
 - Equipped with SEM knob.
 - Can be fitted with closing retainers on request (with surcharge).
 - Size reductions are not permitted.

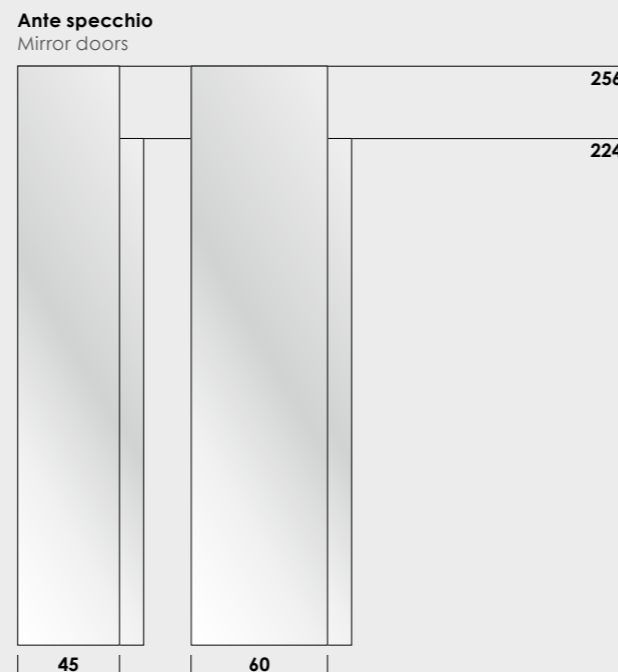

- Cassetti/cassettoni**
- Sono forniti con preforo per maniglia.
 - Guide scorrevoli metalliche regolabili in altezza.
 - Su richiesta, con sovrapprezzo, possono essere dotati di rallentatori di chiusura o, esclusivamente nei cassetti/cassettoni componibili, di guide tipo "Quadro" regolabili in altezza, rallentate o push-pull; in questo caso l'interno cassetto sarà in finitura Charm.
 - I cassettoni L 120 sono costituiti da frontale unico con doppio girocassetto e dotati di guide tipo "Quadro" di serie.
 - Non sono ammesse riduzioni dimensionali.

- Drawers/big drawers**
- Supplied with semi-cut hole for handle.
 - Sliding metal runners adjustable in height.
 - Upon request, at a surcharge, they can be equipped with slow-closing devices or, exclusively in drawers/drawers for modular units, with "Quadro" type guides adjustable in height, slowed down or push-pull; in this case the inside of the drawer will be in Charm finish.
 - The W 120 drawers consist of a single front with double drawer surround and are equipped with "Quadro" type guides as standard.
 - Size reductions are not permitted.

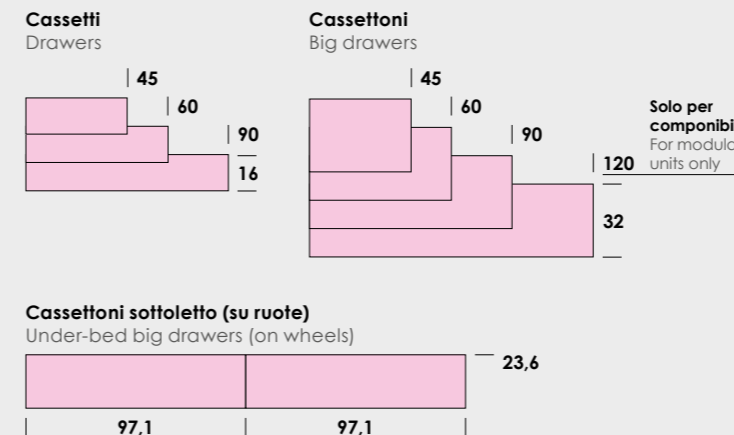

- Ante vasistas/ribalta**
- Sono fornite con preforo per maniglia.
 - Solo per Componibili e Pensili.
 - Non sono ammesse riduzioni dimensionali.

- Lift up/pull-down doors**
- Supplied with pre-cut hole for handle.
 - For Modular units and Wall units only.
 - Size reductions are not permitted.

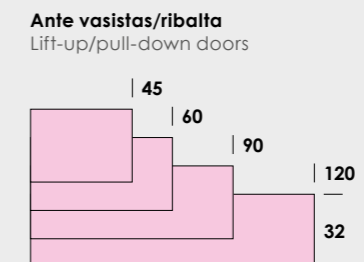

A Finiture in fascia di prezzo A
Finishes in price range A
B Finiture in fascia di prezzo B
Finishes in price range B
☆ Finiture con effetto materico
Finishes with textured effect

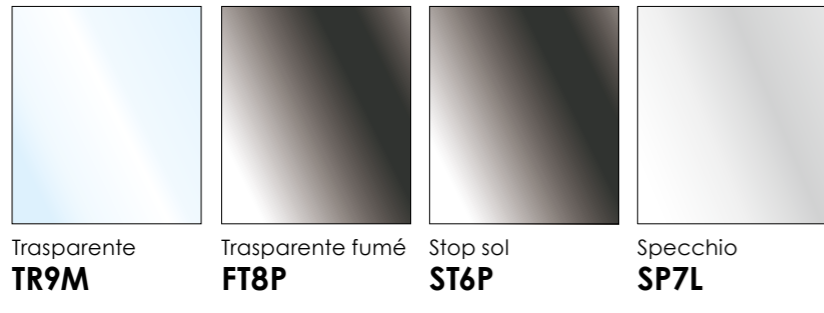

Colori telaio:
Frame colours:

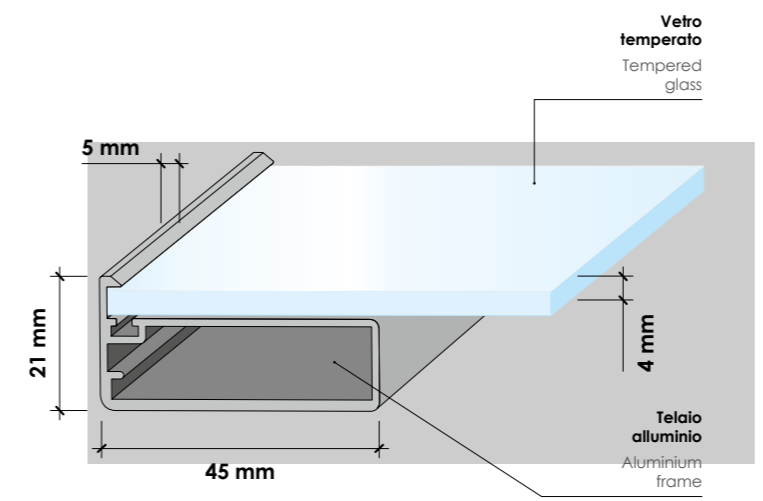

Vetri
Glass

Dimensioni disponibili
Dimensions available

- Ante**
- Dotate di maniglia in tinta integrata nel telaio sempre posizionata a metà altezza dell'anta, escluse le ante H 224 e 256 nelle quali la maniglia è ad H 102 da terra.
 - La maniglia dell'anta WINDOW non si allinea con quelle dell'anta in nobilitato.
 - Non possono essere dotate di serratura.
 - Su richiesta possono essere dotate di rallentatori di chiusura (con sovrapprezzo).
 - Non sono ammesse riduzioni dimensionali.

- Doors**
- These are fitted with handles integrated in the frame always placed halfway up the door, except for doors Ht 224 and 256 where the handle is at Ht 102 from the ground.
 - The handle of the WINDOW door is not in line with the handle of the laminated door.
 - They cannot be fitted with a lock.
 - Can be fitted with closing retainers on request (with surcharge).
 - Size reductions are not permitted.

Ante
Doors

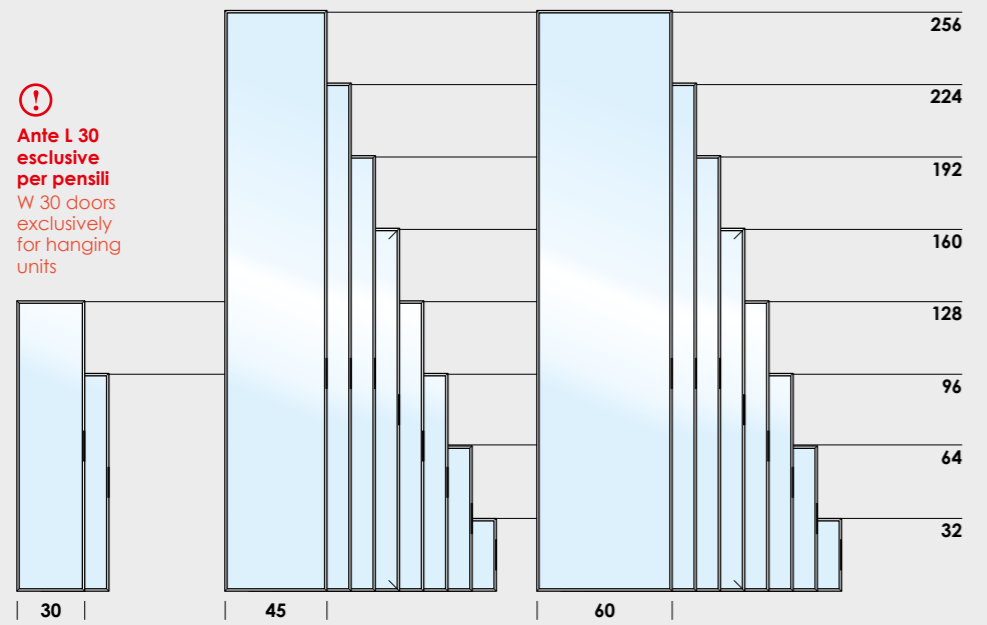

Ante vasistas/ribalta
Lift-up/pull-down doors

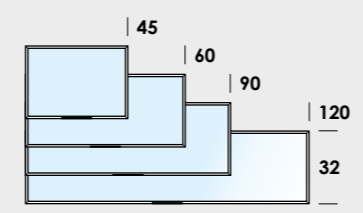

Maniglia colore Alluminio (AL1A) e Titan grey (TG7H)

Alluminio (AL1A) and Titan grey (TG7H) colour handle

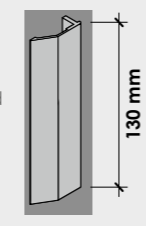



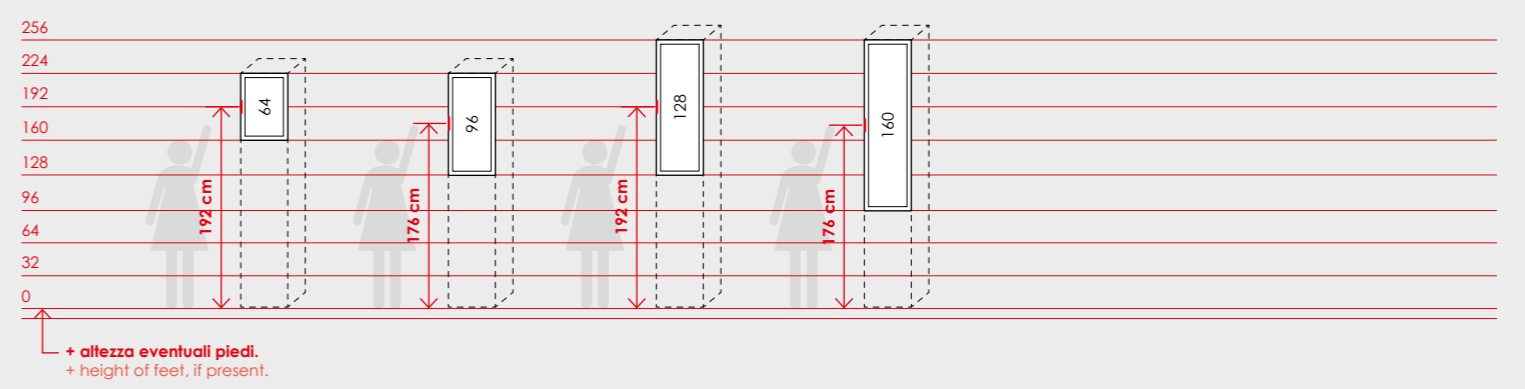

Consigliamo di non posizionare le ante WINDOW nella maniera indicata perché la maniglia potrebbe risultare troppo in alto.
We recommend against positioning WINDOW doors as shown because the handle might be too high up

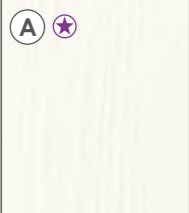
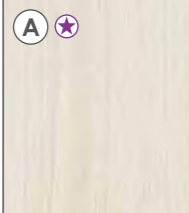

Ante scorrevoli

Sliding doors

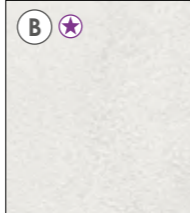
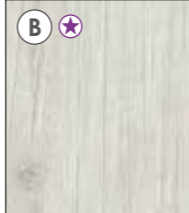
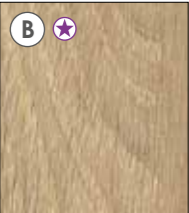
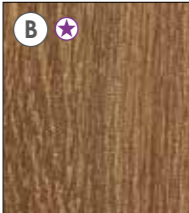
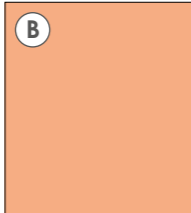
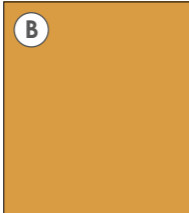
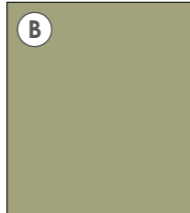
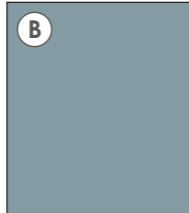
Finiture GRUPPO 1
GROUP 1 finishes

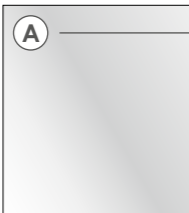
 (A) ☆	 (A) ☆	 (A)	 (A)	 (B) ☆	 (B) ☆
Rovere white RW3Q	Noce brina NB5T	Bianco opaco BI7A	Grigio Dorian GL4R	Cemento artico CA7A	Rovere gesso RG9L
 (B) ☆	 (B) ☆	 (B)	 (B)	 (B)	 (B)
Royal oak RS4B	Rovere cognac RC3Q	Papaya PP7H	Miele ML4B	Oliva LV5T	Cadaques CQ3Q
 (B)	 (A)	<p>Il pannello sul quale viene applicato lo specchio è sempre colore Bianco opaco (BI7A)</p> <p>The panel on which the mirror is applied is always Bianco opaco (BI7A)</p>			
Grigio titanio GZ8T	Specchio SP7L				

Profilo maniglia ante scorrevoli

Sliding doors handle groove strip

Profilo verticale in alluminio
Aluminium vertical trim

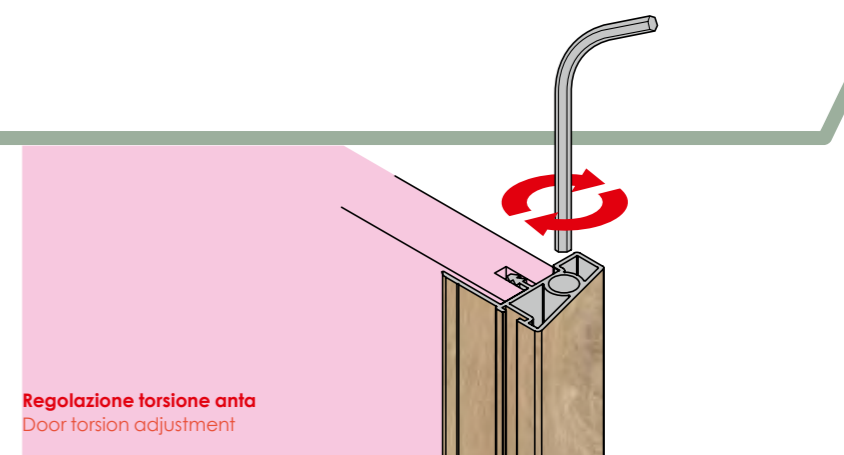
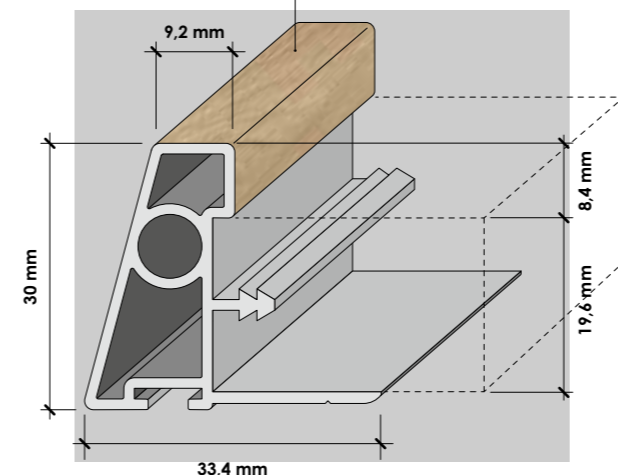

Regolazione torsione ante
Door torsion adjustment

Colori profili maniglia:
Handle groove strip colours:

			
Rovere white RW3Q	Noce brina NB5T	Rovere gesso RG9L	Royal oak RS4B
			
Rovere cognac RC3Q	Bianco opaco BI7A	Grigio Dorian GL4R	Grigio titanio GZ8T

Dimensioni disponibili

Dimensions available

- Ante scorrevoli**
- Su richiesta possono essere dotate di sistema frenante (apertura/chiusura ante) (con sovrapprezzo).
 - Specchio Sp 4 mm applicato su pannello in nobilitato Sp 1,4.
 - Non sono ammesse riduzioni dimensionali.

- Sliding doors
- On request can be equipped with braking system (opening/closing doors) (with surcharge).
 - Mirror Th 4 mm applied on melamine-coated panel Th 1,4.
 - Size reductions are not permitted.

Ante scorrevoli

Sliding doors

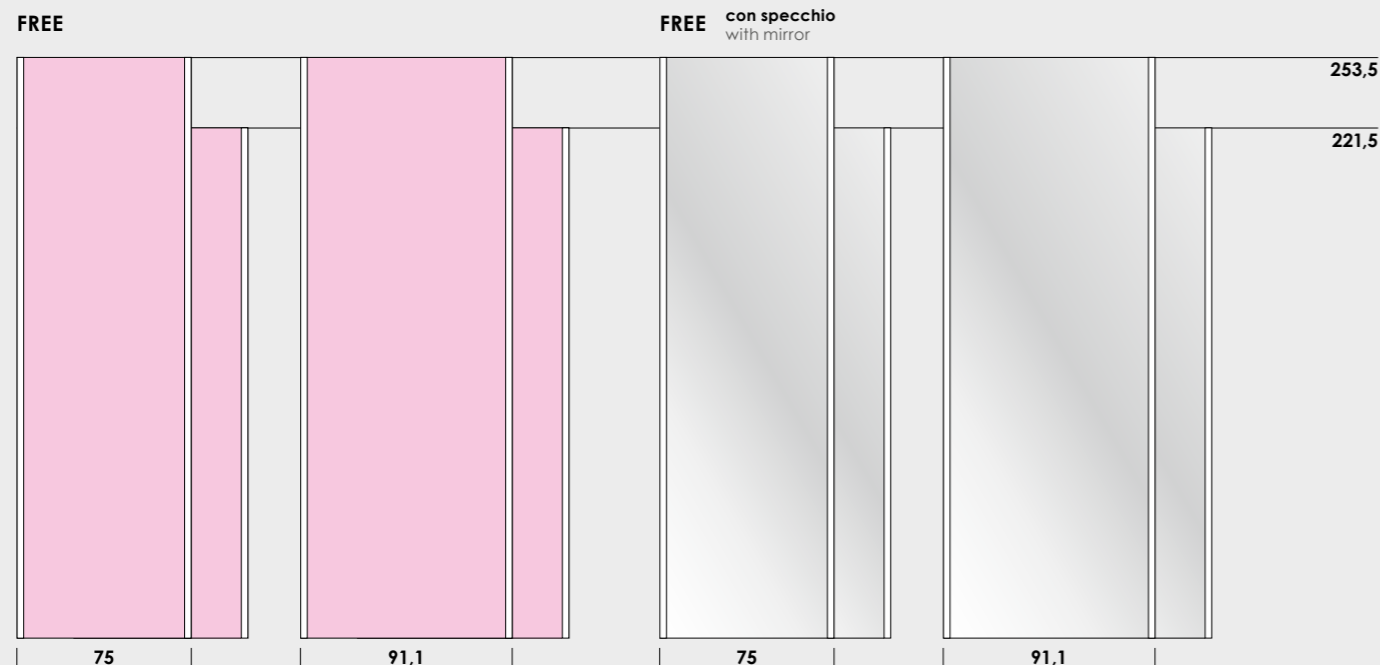

Schema di apertura ante scorrevoli

Opening diagram for sliding doors

Non è possibile invertire il verso di apertura.
The opening direction cannot be inverted.



- (A) Finiture in fascia di prezzo A
Finishes in price range A
- (B) Finiture in fascia di prezzo B
Finishes in price range B
- ☆ Finiture con effetto materico
Finishes with textured effect

⚠ Si eseguono tagli a misura solo se richiesti con disegno esplicativo.
Customized cuts can be made only if you provide an explanatory drawing.

+ 35,00 SOVRAPPREZZO per ogni singolo taglio
SURCHARGE for each cut

				
		RIDUZIONE IN LARGHEZZA REDUCED WIDTH	RIDUZIONE IN ALTEZZA REDUCED HEIGHT	RIDUZIONE IN PROFONDITÀ REDUCED DEPTH
Cassetti e cassettoni	Drawers and big drawers	X	X	X
Ante battenti VOLO	VOLO hinged doors	V	V	-
Ante battenti VOLO con specchio	VOLO hinged doors with mirror	X	X	-
Ante battenti WINDOW	WINDOW hinged doors	X	X	-
Ante vasistas e ribalta	Lift-up and pull-down doors	X	X	-
Ante scorrevoli	Sliding doors	X	X	-
Armadi con ante battenti	Wardrobes with hinged doors	V	V	V
Armadio porta tv	Tv wardrobes	X	V	V
Angoli interi e Cabine	Corner wardrobes and Walk-in wardrobes	X	V	X
Terminali	End units	X	V	X
Terminali PILL e SLASH	PILL and SLASH end units	X	X	X
Librerie terminali ORDER e OLA	ORDER and OLA end bookshelves	X	V	X
Armadi con ante scorrevoli	Wardrobes with sliding doors	X	X	V
Armadi ponte	Overhead wardrobes	V	V	X
Letti a soppalco BRIDGE	BRIDGE loft beds	X	V	X
Letti a castello WINNER, REVOLUTION, TITANO	WINNER, REVOLUTION, TITANO equipped bunk bed	X	X	X
Letti e turche non attrezzati	Not equipped beds and ottomans	X	X	V
Letti e turche attrezzati, divani letto	Equipped beds and ottomans, sofa beds	X	X	X
Letti imbottiti	Padded beds	X	X	X
Piani sagomati	Shaped worktops	X	X	X
Cubolotti e pannelli attrezzati	Cubes and equipped panels	X	X	X
Librerie INFINITY	INFINITY bookshelves	V	V	X
Angolo intero, Terminale INFINITY	INFINITY Full corner, Shaped end unit	X	V	X
Componibili a terra/in appoggio	Floor/support modular units Dpt 45.8	V	V	X
Componibili sospesi e Pensili	Suspended modular units and Hanging units	X	X	X
Moduli sospesi SNAKE	SNAKE suspended modular units	X	X	X
Tavoli e sedie	Tables and chairs	X	X	X
Elementi in vetro	Glass elements	X	X	-
Parti metalliche	Metal parts	X	X	-

RIDUZIONE IN LARGHEZZA REDUCED WIDTH

ARMADI e COMPONENTI
WARDROBES and MODULAR UNITS

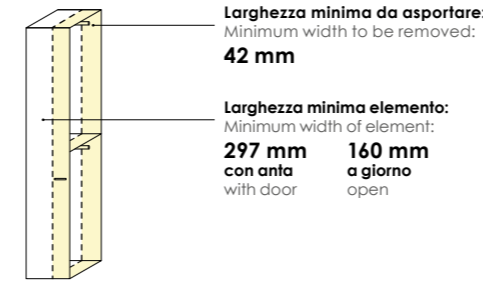

Esempio: per ridurre in larghezza un armadio ad 1 ante si tagliano 5 componenti (fondo, cappello, ripiano, schiena e 1 ante); pertanto il costo di questa lavorazione è di:

$$35,00 \times 5 = 175,00$$

LIBRERIA INFINITY
INFINITY BOOKSHELVES

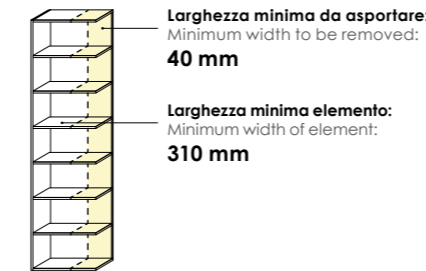

RIDUZIONE IN ALTEZZA REDUCED HEIGHT

ARMADI
WARDROBES

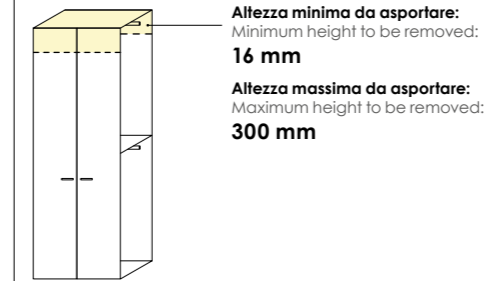

Esempio: per ridurre in altezza un armadio a 2 ante si tagliano 4 componenti (2 ante, schiena e fianco); pertanto il costo di questa lavorazione è di:

$$35,00 \times 4 = 140,00$$

LIBRERIA INFINITY
INFINITY BOOKSHELVES

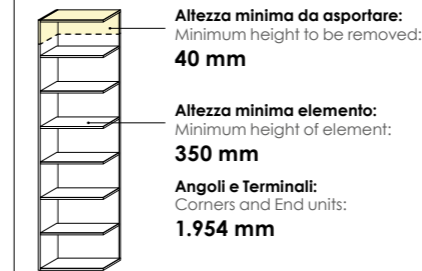

COMPONIBILI
MODULAR UNITS

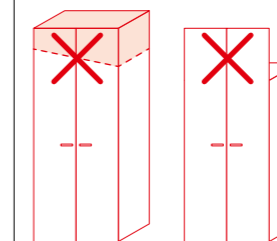
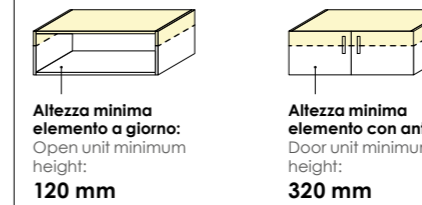

- Si taglia sempre sopra
- NO taglio obliquo
- NO altezza cassa diversa dalle facciate
- It is always cut above
- NO slanted cut
- NO carcasse height different from the fronts

RIDUZIONE IN PROFONDITÀ REDUCED DEPTH

ARMADI
WARDROBES

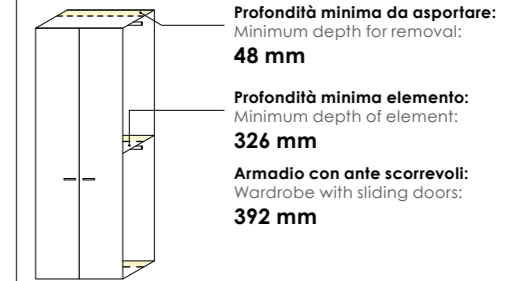

Esempio: per ridurre in profondità un armadio si tagliano 4 componenti (fondo, cappello, ripiano e fianco); pertanto il costo di questa lavorazione è di:

$$35,00 \times 4 = 140,00$$

ELEMENTO CENTRALE
CENTRAL ELEMENT

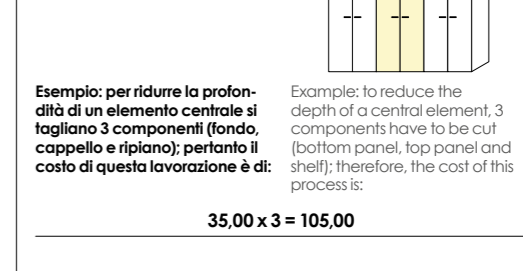

ELEMENTO FINALE
END ELEMENT

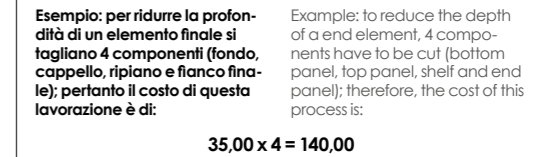

In caso di armadi ridotti in profondità si consiglia l'utilizzo di tubi appendi abiti scorrevoli.
La libreria INFINITY non si riduce in profondità.
With small depth wardrobes we recommend using sliding clothes rails.
The INFINITY bookshelf can not be reduced in depth.

TOP e MENSOLE
TOP and SHELVES

Profondità minima top e mensola: Minimum depth top and shelves: 
200 mm
Top lineare per scrittoio (perde ogni tipo di foratura)
Linear top for desk (it lose all type of holes)
150 mm
Mensole con reggimensola A SCOMPARSA
Shelves with A SCOMPARSA shelf-holders
100 mm
Top per componibili/pensili (perdono ogni tipo di foratura)
Mensole senza reggimensola
Mensole con reggimensola LAMPO e KUB
Top for modular units/hanging units (they lose all type of holes)
Shelves without shelf-holders
Shelves with LAMPO and KUB shelf-holders

Facciate Fronts
VOLO

Finiture GRUPPO 1
GROUP 1 finishes

Finiture GRUPPO 2
GROUP 2 finishes

Rovere white*

A ☆ Rovere white RW3Q	A ☆ Noce brina NB5T	A Bianco opaco BI7A	A Grigio Dorian GL4R	B ☆ Cemento artico CA7A	B ☆ Rovere gesso RG9L
B ☆ Royal oak RS4B	B ☆ Rovere cognac RC3Q	B Grigio titanio GZ8T			
B Papaya PP7H	B Miele ML4B	B Oliva LV5T	B Cadaques CQ3Q		

Vetri Glass

Ante Doors
WINDOW

Colori telaio
Frame colours

Trasparente TR9M	Trasparente fumé FT8P	Stop sol ST6P	Specchio SP7L	Alluminio AL1A	Titan grey TG7H
----------------------------	---------------------------------	-------------------------	-------------------------	--------------------------	---------------------------

Rovere white* Finitura unica per tutti i componenti in pannello presenti a listino non evidenziati con il colore Finiture GRUPPO 1 e/o Finiture GRUPPO 2.
Unique finish for all the panel components shown in the pricelist not highlighted with the color finishes GROUP 1 and/or finishes GROUP 2.

- A** Finiture in fascia di prezzo A
Finishes in price range A
- B** Finiture in fascia di prezzo B
Finishes in price range B
- ☆ Finiture con effetto materico
Finishes with textured effect

MANIGLIE, ACCESSORI, SEDIE E TAVOLI
HANDLES, ACCESSORIES, CHAIRS AND TABLES

Pomelli e maniglie Knobs and handles	pag. 36
Posizionamento pomelli e maniglie Knobs and handles position	pag. 42
Ferramenta Hardware	pag. 46
Campionari e vernici Colour sample sets and paints	pag. 48
Pannelli e bordi Panels and edged	pag. 48
Illuminazione Lighting	pag. 49
Appendiabiti Clothes hook	pag. 49
Sedie Chairs	pag. 50
Tavoli DALLAS DALLAS tables	pag. 52
Ante Doors	pag. 54
Cassetti e cassettoni VOLO VOLO drawers and big drawers	pag. 57
Pannello anta VOLO senza fori cerniera e maniglia VOLO door panel without hinge and handle holes	pag. 58



P11



L W mm	Passo Span mm	COD.	Sovrapprezzo Surcharge	COD.
21	-	G01M	-	VF30.01Y

H Ht mm	21	Sporgenza Projection mm	20
---------------	----	-------------------------------	----

SEM



L W mm	Passo Span mm	COD.	Sovrapprezzo Surcharge	COD.
20	-	H07L	-	VF29.99L

H Ht mm	20	Sporgenza Projection mm	24
---------------	----	-------------------------------	----

SEED Ø 5,2



L W mm	Passo Span mm	COD.	Sovrapprezzo Surcharge	COD.
52	-	H08L	+ 6,00	VF31.24H

H Ht mm	52	Sporgenza Projection mm	24
---------------	----	-------------------------------	----

SEED Ø 7



L W mm	Passo Span mm	COD.	Sovrapprezzo Surcharge	COD.
70	-	H09P	+ 8,00	VF31.25Q

H Ht mm	70	Sporgenza Projection mm	29
---------------	----	-------------------------------	----

BING



! Può essere montata ruotata di 90°
It can be mounted rotated 90°



L W mm	Passo Span mm	COD.	Sovrapprezzo Surcharge	COD.
100	32	E74N	+ 5,00	VF30.02E

H Ht mm	140	Sporgenza Projection mm	25
---------------	-----	-------------------------------	----

CLOUDY



! Posizionamento maniglia:
verticale su ante; orizzontale su ante vasistas/ribalta, cassette e cassettoni
Handle positioning:
vertically on doors; horizontally on vasistas/folding doors, drawers and big drawers



L W mm	Passo Span mm	COD.	COD.	Sovrapprezzo Surcharge	COD.
74	32	H10S	H10S	+ 9,00	VF31.26W

H Ht mm	135	Sporgenza Projection mm	26
---------------	-----	-------------------------------	----

DROP



! Può essere montata ruotata di 90°
It can be mounted rotated 90°



L W mm	Passo Span mm	COD.	Sovrapprezzo Surcharge	COD.
86	32	E73K	+ 5,00	VF30.03M

H Ht mm	140	Sporgenza Projection mm	25
---------------	-----	-------------------------------	----

BEN



L W mm	Passo Span mm	COD.	COD.	Sovrapprezzo Surcharge	COD.
132	96	E34P	E13F	-	VF30.05Z

H Ht mm	26	Sporgenza Projection mm	22
---------------	----	-------------------------------	----

! Maniglie con foratura VERTICALE
Handles with VERTICAL drilling
- Maniglie con foratura ORIZZONTALE
Handles with HORIZONTAL drilling

AL1A Alluminio	LV5T Oliva	RS4B Royal oak
AS7H Alluminio spazzolato	ML4B Miele	RW3Q Rovere white
BI7A Bianco opaco	NB5T Noce brina	
CQ3Q Cadaques	NS3Q Nero spazzolato	
CS4B Champagne spazzolato	PP7H Papaya	
GL4R Grigio Dorian	RC3Q Rovere cognac	
GZ8T Grigio titanio	RG9L Rovere gesso	



VER

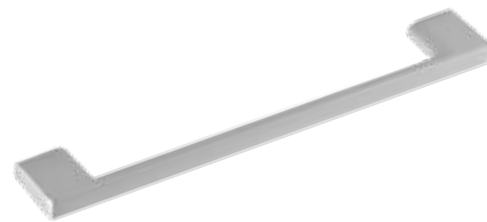

L W mm	Passo Span mm	COD.	COD.	Sovrapprezzo Surcharge	COD.
113	96	E33K	E31Y		VF30.06F
186	160	E36R	T07C		VF30.07N

H Ht mm	9	Sporgenza Projection mm	28
---------------	---	-------------------------------	----

BIS



L W mm	Passo Span mm	COD.	COD.	Sovrapprezzo Surcharge	COD.
192	160	T03C	G35F	-	VF30.08U

H Ht mm	9	Sporgenza Projection mm	20
---------------	---	-------------------------------	----

GAB

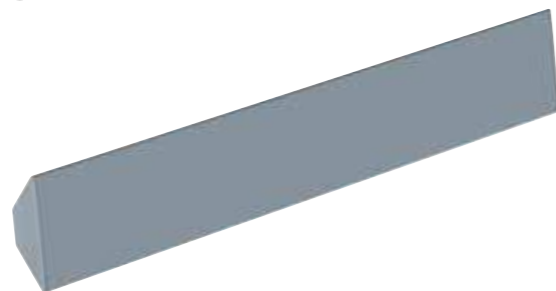

L W mm	Passo Span mm	COD.	COD.	Sovrapprezzo Surcharge	COD.
304	160	E16C	E15A		VF30.10X

H Ht mm	46	Sporgenza Projection mm	18
---------------	----	-------------------------------	----

LIG



L W mm	Passo Span mm	COD.	COD.	Sovrapprezzo Surcharge	COD.
175	160	T04L	U00V	-	VF30.11D

H Ht mm	20	Sporgenza Projection mm	35
---------------	----	-------------------------------	----

Maniglie con foratura VERTICALE
Handles with VERTICAL drilling
 Maniglie con foratura ORIZZONTALE
Handles with HORIZONTAL drilling

AL1A Alluminio	LV5T Oliva	RS4B Royal oak
AS7H Alluminio spazzolato	ML4B Miele	RW3Q Rovere white
BI7A Bianco opaco	NB5T Noce brina	
CQ3Q Cadaques	NS3Q Nero spazzolato	
CS4B Champagne spazzolato	PP7H Papaya	
GL4R Grigio Dorian	RC3Q Rovere cognac	
GZ8T Grigio titanio	RG9L Rovere gesso	

PUL



L W mm	Passo Span mm	COD.	COD.	Sovrapprezzo Surcharge	COD.
192	160	G28P	G53Z		VF30.12L

H Ht mm	18	Sporgenza Projection mm	19
---------------	----	-------------------------------	----

PURA

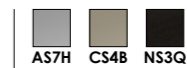

L W mm	Passo Span mm	COD.	COD.	Sovrapprezzo Surcharge	COD.
192	160	E76R	E75C		VF30.18Z

H Ht mm	16	Sporgenza Projection mm	18
---------------	----	-------------------------------	----

SAK



L W mm	Passo Span mm	COD.	COD.	Sovrapprezzo Surcharge	COD.
180	160	E04U	T06R		VF30.13S

H Ht mm	14	Sporgenza Projection mm	35
---------------	----	-------------------------------	----

BLADE



L W mm	Passo Span mm	COD.	COD.	Sovrapprezzo Surcharge	COD.
445	-	-	H01A		VF30.14Y
595	-	-	H02E		VF30.15E
895	-	-	H03M		VF30.16M
1195	-	H05Z	H04F		VF30.17T

H Ht mm	14	Sporgenza Projection mm	20
---------------	----	-------------------------------	----

BAND

! Maniglia a tutta altezza/larghezza. Negli elementi con coppia ante è prevista una sola maniglia.
Full-height/width handle. Elements with two doors have only one handle.



L W mm	Passo Span mm	COD.	☐	COD.	☐	COD.	Sfusa Loose
314	-	H11Q	☐	-	☐	VF31.27C	29,00
634	-					VF31.28K	34,00
954	-					VF31.29R	39,00
1274	-					VF31.30N	43,00
1594	-					VF31.31U	48,00
1914	-					VF31.32A	53,00
2234	-					VF31.33G	58,00
2554	-					VF31.34P	63,00
445	-	-	☐	H11Q	☐	VF31.35V	30,00
595	-					VF31.36B	33,00
895	-					VF31.37H	38,00
1195	-					VF31.38Q	42,00

H
Ht
mm 40 Sporgenza
Projection
mm 25

TALL

! Maniglia a tutta altezza. Negli elementi con coppia ante è prevista una sola maniglia.
Full-height handle. Elements with two doors have only one handle.



L W mm	Passo Span mm	COD.	☐	COD.	☐	COD.	Sfusa Loose
154	-	H06B	☐	-	☐	VF29.90B	15,00
314	-					VF29.91H	19,00
634	-					VF29.92Q	27,00
954	-					VF29.93W	30,00
1274	-					VF29.94C	34,00
1594	-					VF29.95K	39,00
1914	-					VF29.96R	43,00
2234	-					VF29.97X	47,00
2554	-					VF29.98D	50,00

H
Ht
mm 33 Sporgenza
Projection
mm 26

☐ Maniglie con foratura VERTICALE
Handles with VERTICAL drilling
☐ Maniglie con foratura ORIZZONTALE
Handles with HORIZONTAL drilling

AL1A Alluminio
AS7H Alluminio spazzolato
BI7A Bianco opaco
CQ3Q Cadaques
CS4B Champagne spazzolato
GL4R Grigio Dorian
GZ8T Grigio titanio

LV5T Oliva
ML4B Miele
NB5T Noce brina
NS3Q Nero spazzolato
PP7H Papaya
RC3Q Rovere cognac
RG9L Rovere gesso

RS4B Royal oak
RW3Q Rovere white

Posizionamento pomelli e maniglie

Knobs and handles position



Schema pomelli

Knobs diagram

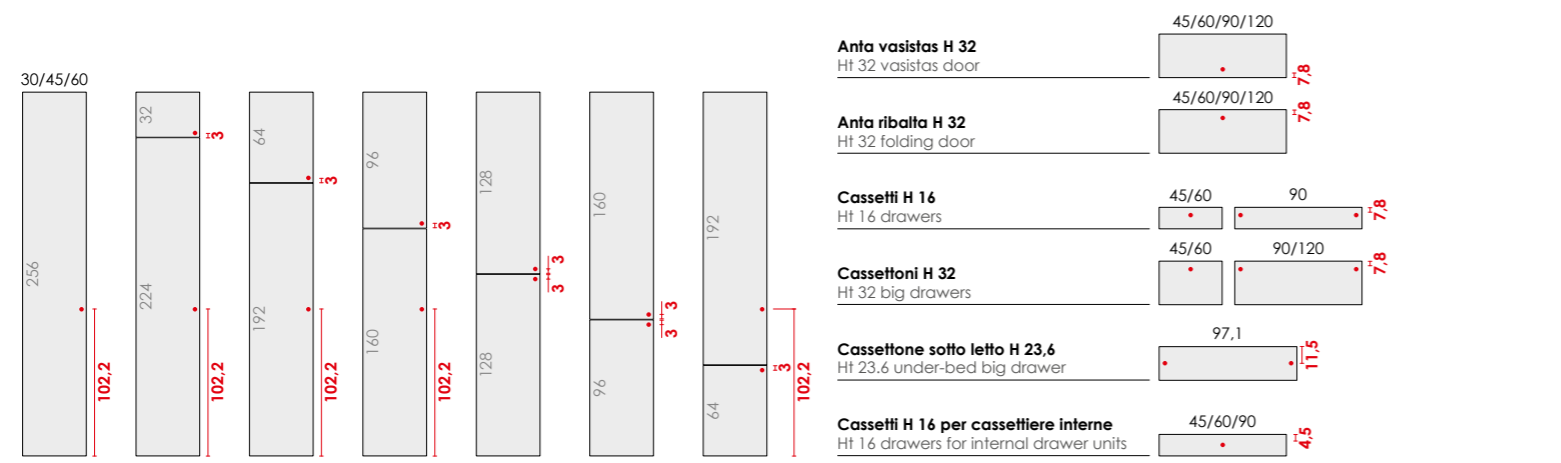

Schema pomelli SEED

SEED knobs diagram

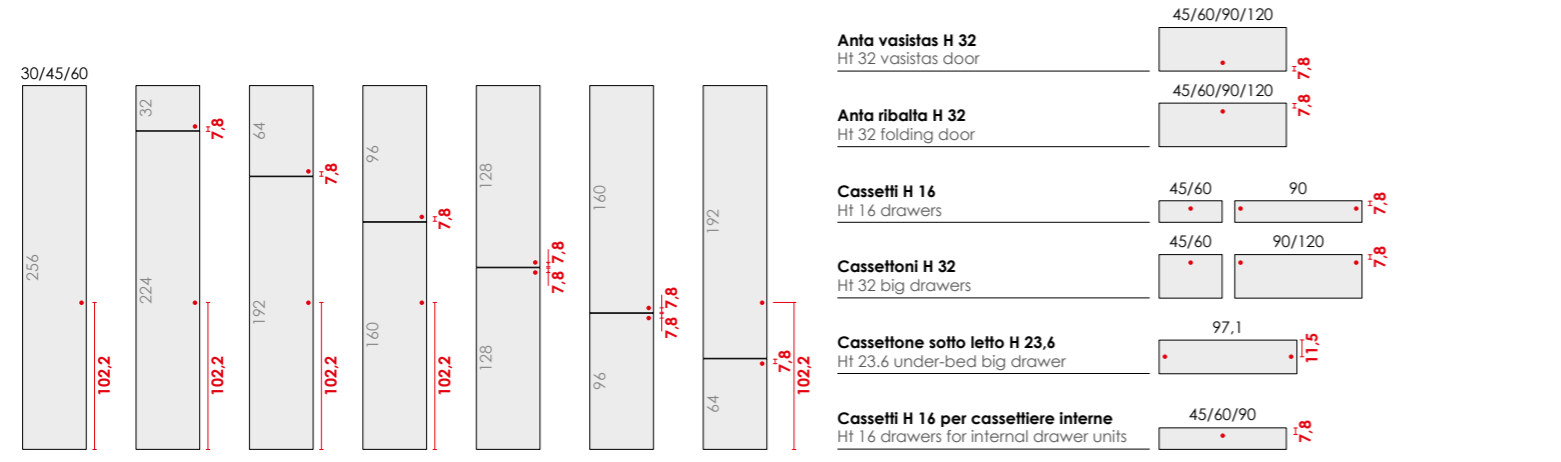
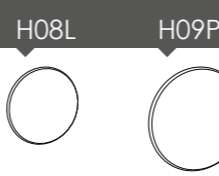

Schema maniglie passo 3,2

Pitch 3.2 handles diagram

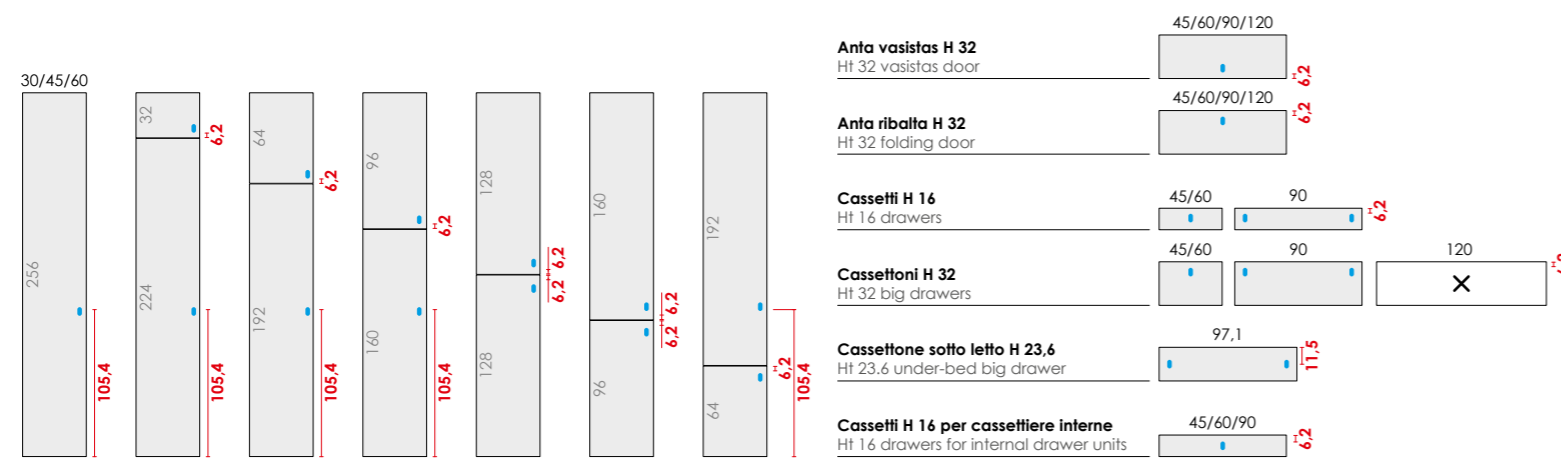
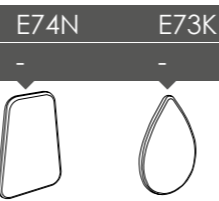

Maniglie con foratura VERTICALE
Handles with VERTICAL drilling

Maniglie con foratura ORIZZONTALE
Handles with HORIZONTAL drilling

Le maniglie non si possono montare
The handles indicated cannot be assembled

Schema maniglie passo 3,2

Pitch 3.2 handles diagram

H10S
H10S

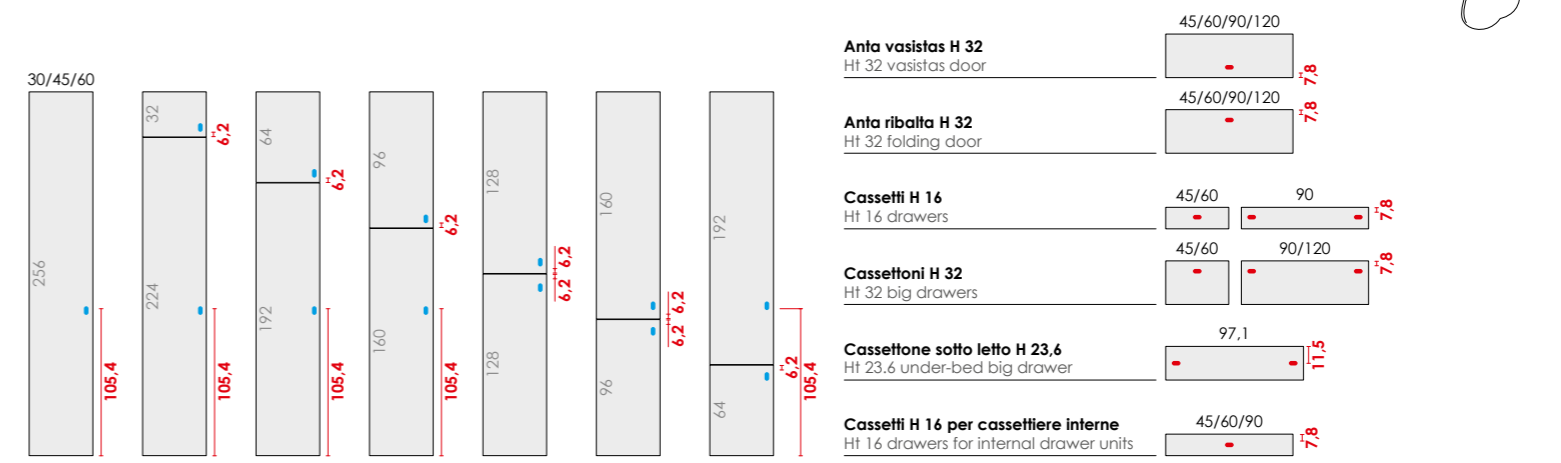
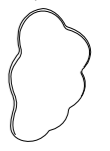

Schema maniglie passo 9,6

Pitch 9.6 handles diagram

E34P
E13F

E33K
E31Y

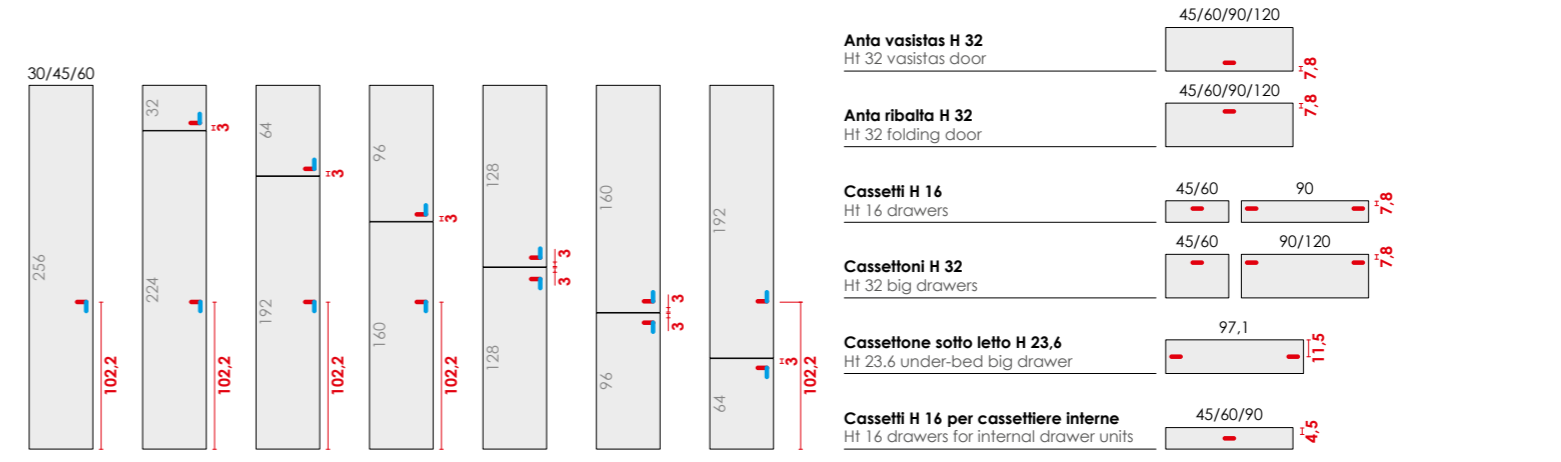
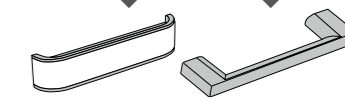

Schema maniglie passo 16

Pitch 16 handles diagram

E36R
T07C

T03C
G35F

E16C
E15A

T04L
U00V

G28P
G53Z

E76R
E75C

E04U
T06R

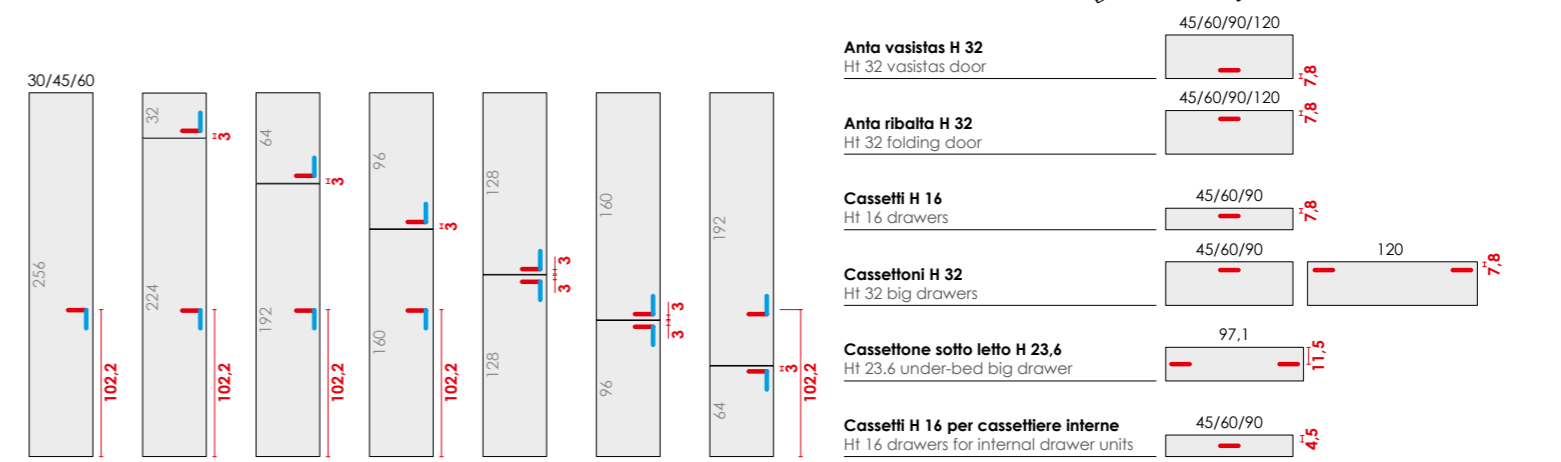
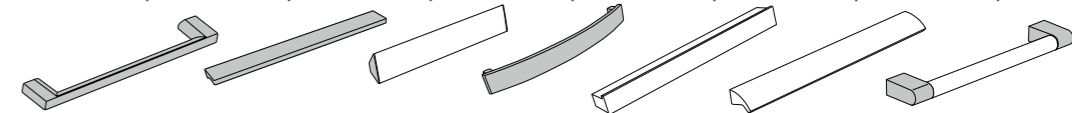

Maniglie, accessori,
sedie e tavoli
Handles, accessories,
chairs and tables

Posizionamento pomelli e maniglie

Knobs and handles position

Schema maniglie BLADE

BLADE handles diagram

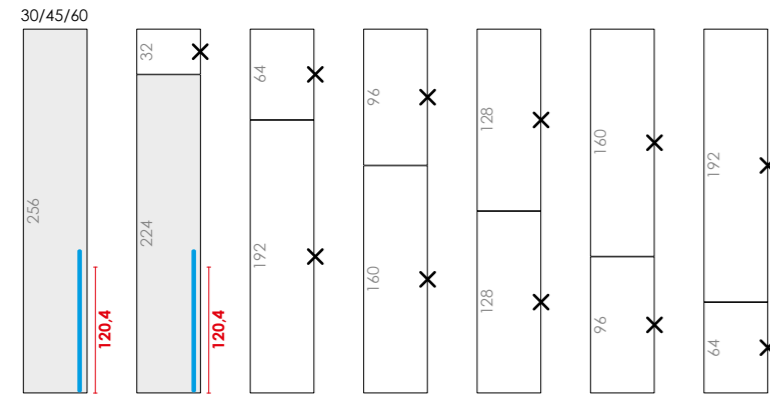
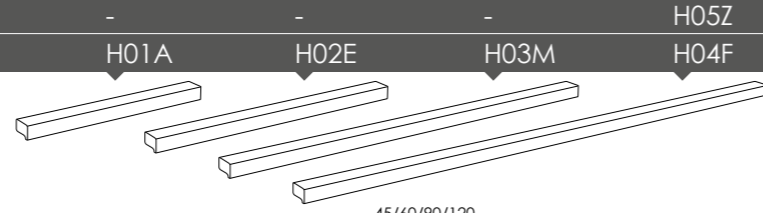

Anta vasistas H 32 Ht 32 vasistas door	45/60/90/120	
Anta ribalta H 32 Ht 32 folding door	45/60/90/120	3,5 3,5
Cassetti H 16 Ht 16 drawers	45/60/90	3,5
Cassettoni componibili H 32 Ht 32 modular units big drawers	45/60/90/120	3,5
Cassettone sotto letto H 23,6 Ht 23.6 under-bed big drawer	97,1	X
Cassetti H 16 per cassettiere interne Ht 16 drawers for internal drawer units	45/60/90	X

Schema maniglie BAND

BAND handles diagram



H11Q
H11Q

! Maniglie a tutta altezza/larghezza. Negli elementi con coppia ante è prevista una sola maniglia.
Full-height/width handles. Elements with two doors have only one handle.

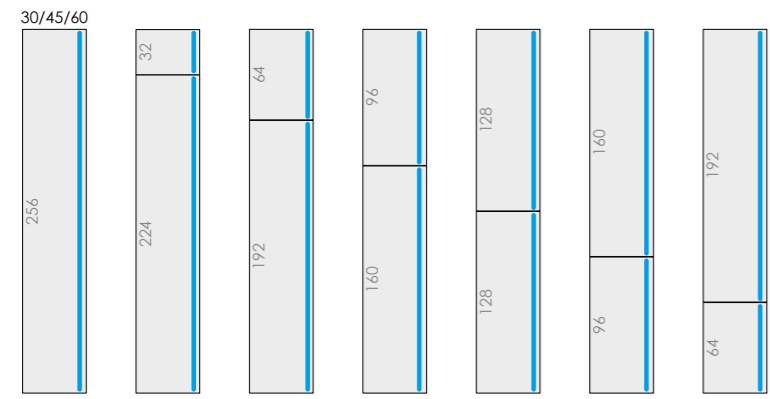

Anta vasistas H 32 Ht 32 vasistas door	45/60/90/120	
Anta ribalta H 32 Ht 32 folding door	45/60/90/120	
Cassetti H 16 Ht 16 drawers	45/60/90	
Cassettoni H 32 Ht 32 big drawers	45/60/90/120	
Cassettone sotto letto H 23,6 Ht 23.6 under-bed big drawer	97,1	X
Cassetti H 16 per cassettiere interne Ht 16 drawers for internal drawer units	45/60/90	X

Schema maniglie TALL

TALL handles diagram



H06B

! Maniglie a tutta altezza. Negli elementi con coppia ante è prevista una sola maniglia.
Full-height handles. Elements with two doors have only one handle.

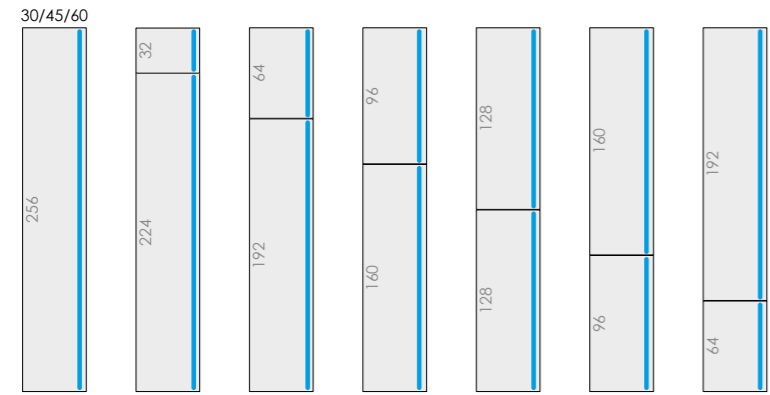

Anta vasistas H 32 Ht 32 vasistas door	45/60/90/120	X
Anta ribalta H 32 Ht 32 folding door	45/60/90/120	X
Cassetti H 16 Ht 16 drawers	45/60 90	
Cassettoni H 32 Ht 32 big drawers	45/60 90 120	X
Cassettone sotto letto H 23,6 Ht 23.6 under-bed big drawer	97,1	X
Cassetti H 16 per cassettiere interne Ht 16 drawers for internal drawer units	45/60/90	X

- Maniglie con foratura VERTICALE
Handles with VERTICAL drilling
- Maniglie con foratura ORIZZONTALE
Handles with HORIZONTAL drilling
- Le maniglie non si possono montare
The handles indicated cannot be assembled

Cerniere
Hinges

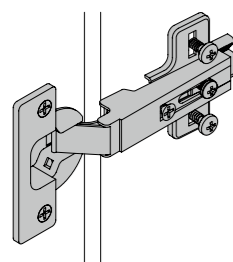

Rallentatore di chiusura per ante battente
Closing retainer for hinged doors

* Il rallentatore di chiusura è applicabile alle cerniere indicate.
The closing retainer is applicable to the indicated hinges.

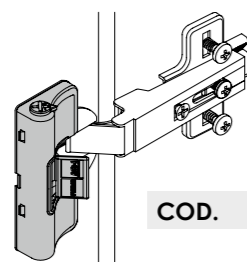

Singolo
(per ante H 32-64-96-128-160-192)
Single
(for doors Ht 32-64-96-128-160-192)

Doppio
(per ante H 224-256)
Double
(for doors Ht 224-256)

COD. VF32.00A

COD. VF32.01G

Descrizione: Description:	COD.	Da utilizzare su: To be used on:
Cerniera a 110° completa di basetta (4 pezzi) 110° hinge with mounting plate (4 pieces)	VF32.02P * 13,00	Ante armadi ed elementi soprabarra Doors for wardrobes and over bar elements
Cerniera a 180° completa di basetta (4 pezzi) 180° hinge with mounting plate (4 pieces)	VF32.03V 45,00	Ante angoli interi armadio Doors for corner wardrobes
Cerniera a 45° completa di basetta (4 pezzi) 45° hinge with mounting plate (4 pieces)	VF32.04B * 25,00	Ante cabine ad angolo Doors for corner walk-in wardrobes
Cerniera a 30° completa di basetta (4 pezzi) 30° hinge with mounting plate (4 pieces)	VF32.05H * 25,00	Ante terminali End units doors
Cerniera in luce completa di basetta (2 pezzi) Flush hinge with mounting plate (2 pieces)	VF32.06Q * 10,00	Ante scalette, armadio P 90 per letti a soppalco BRIDGE e cabina REVOLUTION Ladders, BRIDGE loft beds Dpt 90 and REVOLUTION walk-in wardrobe doors
Cerniera decelerata 110° completa di basetta (4 pezzi) 110° decelerate hinge with mounting plate (4 pieces)	VF32.07W 25,00	Ante libreria INFINITY Doors for INFINITY bookshelf
Cerniera a 110° completa di basetta (4 pezzi) 110° hinge with mounting plate (4 pieces)	VF32.08C * 13,00	Ante armadio REVOLUTION e componibili (no ante ribalta) REVOLUTION wardrobe and modular units doors (no folding door)

Guide metalliche standard
regolabili in altezza
Standard height-adjustable metal
runners

Per cassetti e cassettoni (2 pezzi)
For drawers and big drawers (2 pieces)



COD. VF32.12U

COD. VF32.13A

Rallentatore di chiusura per cassetto
Closing retainer for drawers

È sufficiente 1 rallentatore per i cassetti L 45 / 60 / 90 e cassettoni L 45 / 60. Sui cassettoni L 90 sono necessari 2 rallentatori.
1 closing retainer is sufficient for drawers W 45 / 60 / 90 and big drawers W 45 / 60. 2 closing retainers are required on big drawers W 90.

COD. VF32.11N

Guide metalliche tipo "Quadro"
regolabili in altezza
Type "Quadro" height-adjustable
metal runners

Per cassetti e cassettoni (2 pezzi)
For drawers and big drawers (2 pieces)

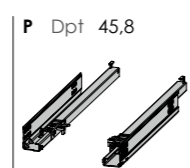

COD. VF35.01V

COD. VF35.02B

Rallentate
With slowed down

COD. VF35.64X

COD. VF35.65D

Con push pull
With push pull

Reggi fondino
per cassetti e cassettoni
Bottom panel support
for drawers and large drawers

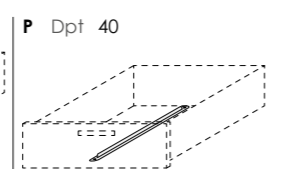
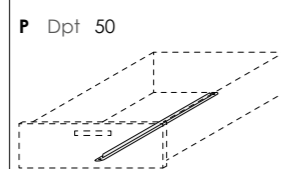

COD. VF32.14G

COD. VF32.15P

Cricchetto per
apertura push-pull
1 pezzo
Push-pull opening
system ratchet
1 piece

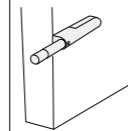

COD. VF32.16V

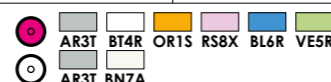
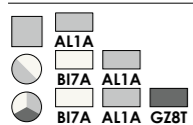

Provvisti di ferramenta per fissaggio a pannello.
In caso di fissaggio a muro la scelta del tipo di tassello da utilizzare dovrà essere fatta dal montatore sulla base delle caratteristiche della parete.
Complete with hardware for fixing to panel.
In case of wall fixing the choice of hardware depends on the wall conditions and should be made by the assembler.

Kit 4 piedini circolari salvamobile H 0,5 Ø 2 Kit 4 circular feet Ht 0.5 Ø 2	Kit 4 piedini rettangolari salvamobile H 0,7 Kit 4 rectangular feet Ht 0.7	Piedini regolabili per armadi (2 pezzi) 1 Kit ogni fianco Adjustable feet for wardrobes (2 pieces) 1 Kit per side panel	Piedini regolabili per armadi con ante scorrevoli (4 pezzi) Adjustable feet for wardrobes with sliding doors (4 pieces)	Piedini regolabili H 0,8 per libreria INFINITY (4 pezzi) Adjustable feet Ht 0.8 for INFINITY bookshelf (4 pieces)
COD. VF32.17B	COD. VF32.18H	COD. VF32.19Q	COD. VF32.20M	COD. VF32.21T

Piedini regolabili per pannelli ponte (2 pezzi per pannello) Adjustable feet for overhead structure panels (2 pieces for panel)	Reggipiani in metallo per ripiani in nobilitato (4 pezzi) Metal shelves supports for melamine shelves (4 pieces)	Reggipiani in metallo per ripiani in vetro (4 pezzi) Metal shelves supports for glass shelves (4 pieces)	Piastrine reggi rete in metallo per letti (4 pezzi) Metal plates for bed base support for beds (4 pieces)	Coppia staffe per aggancio testata al giroletto metallico Pair of brackets for fixing headboard to metal bed frame
COD. VF32.22Z	COD. VF32.23F	COD. VF32.24N	COD. VF32.25U	COD. VF32.26A

Coppie reggimensola Couple shelf holders A scomparsa Integrated	LAMPO L W 3,5 P Dpt 8 Apertura: Opening: min 1,5 max 3,5	KUB L W 3 P Dpt 4 Apertura: Opening: min 2 max 4	Appendi abiti scorrevole Sliding clothes rail Consigliati per armadi ridotti in profondità: P 40 = per profondità superiori a 40 cm. P 24,5 = per profondità inferiori a 40 cm. Recommended for wardrobes with small depth: Dpt 40 = for depth greater than 40 cm. Dpt 24.5 = for depth less than 40 cm.	
COD. VF32.27G	COD. VF32.28P	COD. VF32.29V	COD. VF32.30S	COD. VF32.31Y

Piedini regolabili - Confezione 4 pezzi Adjustable feet - Pack of 4				
ALFA 16 H Ht 1,6	ALFA 25 H Ht 2,5	ETA L W 10 H Ht 4	SIGMA L W 8,3 H Ht 11	GAMMA L W 3,6 H Ht 11 centrale central
COD. VF33.86N	COD. VF32.32E	COD. VF32.33M	COD. VF32.34T	COD. VF32.35Z

Coppia piedi cilindrici trasparenti Per letti Pair of transparent cylindrical feet For beds	Kit 2 ruote con freno Per letti Set 2 casters with brake For beds	Kit 4 ruote con freno Per cassettiere Set 4 casters with brake For chest of drawers	Kit 4 ruote senza freno Per cassettiere e porta PC Set 4 casters without brake For chest of drawers and PC holder	Parapolvere Dust blocker Per ante a battente Taglio a cura del montatore For hinged doors Cut by assembler
COD. VF32.36F	COD. VF32.37N	COD. VF32.38U	COD. VF32.39A	COD. VF32.40X

Campionari e vernici

Colour sample sets and paints

Campionario colori

Colour samples

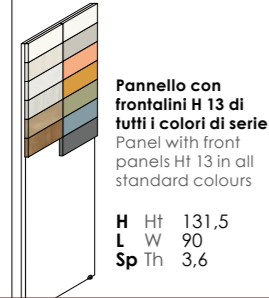

Aggiornamento per campionario colori

Update for colour specification chart

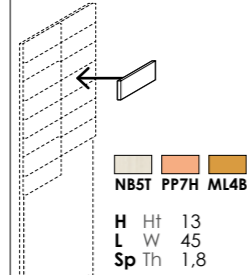

Ordinabili sulla divisione "Materiali punto vendita"
Can be ordered from the "Point of Sale Materials" division

Vernice in bottiglietta per ritocchi

Bottle of paint for repairs

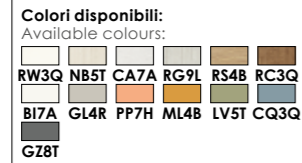

COD. VF32.44Y

Vernice e fondo all'acqua (2 barattoli da 500 ml cadauno)

Water-based primer and paint (2 tins of 500 ml each)

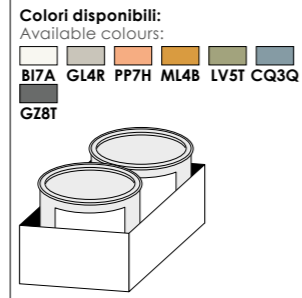

COD. VF32.45E

Pannelli e bordi

Panels and edged

L'altezza del pannello è definita dal disegno verticale della venatura del legno (se presente)
Height of panel is defined by the vertical matching of the wood grain (if any)

Pannelli bordati

Sp 1,8
Edged panels
Th 1,8

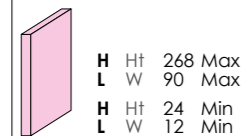

COD. VF32.46M

Pannelli bordati

Sp 2,5
Edged panels
Th 2,5

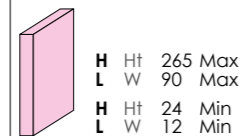

COD. VF32.47T

Pannelli non bordati

Sp 1,8
Panels without edge
Th 1,8

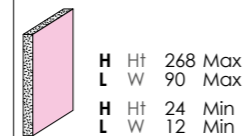

COD. VF32.48Z

Pannelli non bordati

Sp 2,5
Panels without edge
Th 2,5

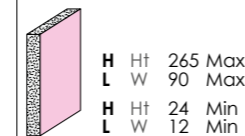

COD. VF32.49F

Bordo sfuso precollato per pannelli a misura e fianchi

Edging pre-glued for custom-made panels and side panels

H Ht 2,8
Sp Th 0,04

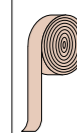

COD. VF32.50C

Bordo sfuso in ABS non adesivo

Edging in ABS not adhesive

H Ht 2,8
Sp Th 0,08

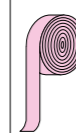

COD. VF32.51K

Coprifori adesivi

Sticky hole covers

(8 pezzi Ø 13 mm)
(8 pieces Ø 13 mm)

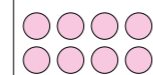

COD. VF32.53X

(8 pezzi Ø 20 mm)
(8 pieces Ø 20 mm)

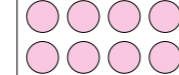

COD. VF32.54D

Illuminazione

Lighting

Faretto LED Ø 6,5

LED spotlights Ø 6,5

12 volt 1,7 watt.
12 volt 1.7 watt.

Da completare con alimentatore
To be completed with power pack

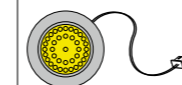

COD. VF32.55L

Alimentatore

Power pack

(cavo L 200 cm - 20 watt) in grado di supportare da 1 a 6 faretti
(cable W 200 cm - 20 watt) can power from 1 to 6 spotlights



COD. VF32.56S

Interruttore wireless

Wireless switch

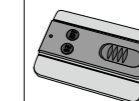

COD. VF32.57Y

Lampada LED

LED lamp

Dotata di batteria al litio integrata ricaricabile tramite cavo micro USB (non incluso). Applicabile con le viti fornite o con calamite adesive. Con sensore di presenza.
Equipped with integrated lithium battery rechargeable via micro USB cable (not included). Applied with the provided screws or with adhesive magnets. With presence sensor.

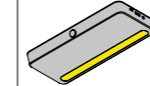

L W 15
P Dpt 6,5
H Ht 1,4

COD. VF32.58E

Lampada led SPARK

SPARK LED lighting

Interruttore manuale o sensore di luce azionabile con interruttore laterale. Applicabile con le viti fornite o con velcro biadesivo. 3 batterie da 1,5v AAA non incluse.
Manual switch or light sensor that can be operated with the side switch. Applied with the provided screws or with biadhesive velcro. 3 - 1.5v AAA batteries not included.

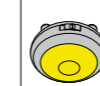

Ø 9,1
H Ht 4,4

COD. VF32.59M

Lampada led SMARTY

SMARTY led lamp

Dotata di batteria integrata ricaricabile tramite cavo USB (incluso). Si aggancia a due placche magnetiche applicabili con viti o biadesivo fornito. Con sensore di presenza.
Equipped with integrated battery rechargeable via USB cable (included). Attaches to two magnetic plates that can be applied with the screws or double-sided tape provided. With presence sensor.

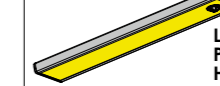

L W 40,5
P Dpt 4
H Ht 1

COD. VF34.99S

Kit illuminazione led per testate letti.

Led lighting kit for bed headboards.

Fascia led L 120, 1 interruttore, cablaggi
Led strip W 120, 1 switch, wiring

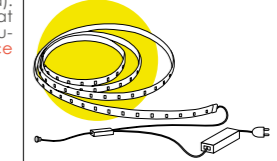

COD. VF34.00K

Illuminazione con sensore

Lighting with sensor

Kit completi di 1 alimentatore. Cover colore Alluminio e Titanio.
Complete kits with 1 power pack. Cover color Aluminum and Titanium.

L W 11,2
P Dpt 19,2
Sp Th 0,6

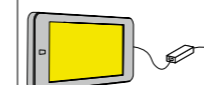

COD. VF32.63C

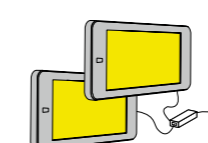

COD. VF32.64K

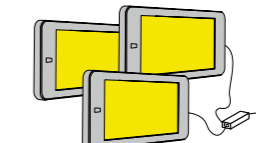

COD. VF32.65R

Appendiabiti

Clothes hook

BOLLINO

Ø 10
P Dpt 4

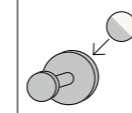

COD. VF32.61Q

PLUS

H Ht 6,5
L W 4,3
P Dpt 3



COD. VF32.62W

SEED Ø 5,2

3 appendiabiti
3 clothes hook

Ø 5,2
P Dpt 2,4

Da fissare a pannello
To be fixed to panel



COD. VF35.63R

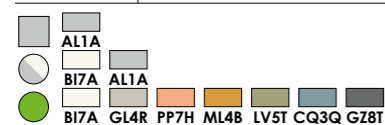

KART

Scocca in polipropilene termoformato. Struttura in tubolare metallico colore Alluminio (AL1A).
Thermoformed polypropylene seat.
Metal tubular structure in Aluminium (AL1A) colour.



H Ht 83 seduta
L W 43,5 seat
P Dpt 50 H Ht 46

Colori disponibili:
Available colours:
Y33R Z13K Z15L Z14G Z35F
Z16R

COD. VF32.66X

KART

Elevazione a gas. Scocca in polipropilene termoformato. Struttura colore nero.
Pneumatic suspension.
Thermoformed polypropylene shell. Black frame.



H Ht 93 seduta
L W 58 seat
P Dpt 58 H Ht 43+53

Colori disponibili:
Available colours:
Y33R Z13K Z15L Z14G Z35F
Z16R

COD. VF32.67D

NOEMI

Fondino e struttura in legno.
Wooden seat and structure.



H Ht 82 seduta
L W 44 seat
P Dpt 51 H Ht 45

Colori disponibili:
Available colours:
B17A GL4R ML4B LV5T CQ3Q
GZ8T

COD. VF32.74Q

ARIES

Fondino e struttura in propilene.
Propylene seat and structure.



H Ht 82 seduta
L W 48 seat
P Dpt 47 H Ht 46

COD.
JA11.03M Bianco ottico
JA11.05Z Tortora
JA11.06F Nero

TRAK

Con ruote e girevole
With wheels and swivel



Elevazione meccanica. Scocca in polipropilene termoformato. Struttura in metallo.
Mechanical lift system. Thermoformed polypropylene shell. Metal structure.

H Ht 92,5 seduta
L W 60 seat
P Dpt 60 H Ht 42+55

Colori struttura:
Structure colours:
B17A GL4R PP7H ML4B LV5T
CQ3Q GZ8T AL1A
Colori seduta:
Seat colours:
Y33R Z13K Z15L
Z14G Z35F Z16R

COD. VF32.71V

PUNTO

Con ruote e girevole
With wheels and swivel

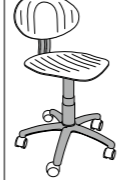

Elevazione a gas. Fondino e schienale in plastica atossica. Struttura colore grigio.
Pneumatic suspension. Back and seat in non-toxic plastic. Structure in grey colour.

H Ht 76-87,5 seduta
L W 60 seat
P Dpt 60 H Ht 39+50,5

Colori disponibili:
Available colours:
Z01B X27A X28D X29G Z02K
Z17W X31H X32M

COD. VF32.70P

STEP

Monoscocca in propilene.
Polypropylene body.



H Ht 80 seduta
L W 50,5 seat
P Dpt 55 H Ht 46,5

Colori struttura:
Structure colours:
K32W K33Z

COD. VF35.70B

NICE

Struttura e seduta in propilene.
Structure and seat in propylene.



H Ht 83 seduta
L W 43 seat
P Dpt 52 H Ht 46

Colori struttura:
Structure colours:
K38R K39U K40X
Ordinando il K39U (Sabbia Nice) la sedia risulterà bicolore, con seduta e schienale colore bianco e struttura colore sabbia.
By ordering the K39U (Sabbia Nice) the chair will be two-coloured, with a white seat and back and a sand-coloured structure.

COD. VF35.71H

LUNA

Scocca in polipropilene.
Polypropylene body.



H Ht 80 seduta
L W 54 seat
P Dpt 52 H Ht 45

Colori struttura:
Structure colours:
K28F K29K K30N K31T

COD. VF35.66L

LUNA

Con seduta imbottita
Scocca in polipropilene.
With cushion
Polypropylene body.



H Ht 80 seduta
L W 54 seat
P Dpt 52 H Ht 45

Colori struttura:
Structure colours:
K28F K29K K30N K31T
Rivestimento seduta imbottita
Cushion cover
Z86Y Z87B

COD. VF35.67S

LIPSIA

Non sfoderabile. Poliuretano flessibile densità 25 kg/m³.
Covers not removable. Flexible polyurethane, density 25 kg/m³.



H Ht 99 seduta
L W 45 seat
P Dpt 58 H Ht 49

Colori disponibili:
Available colours:
RW3Q GL4R

Colore seduta:
Seat colour:
0025 0021 0031
RITUAL - RV26RT

COD. VF32.73H

LUNA

Scocca in polipropilene.
With wheels
Polypropylene body.



H Ht 79 seduta
L W 70 seat
P Dpt 70 H Ht 45,5

Colori struttura:
Structure colours:
K28F K29K K30N K31T

COD. VF35.68Y

LUNA

Scocca in polipropilene.
With wheels and cushion
Polypropylene body.

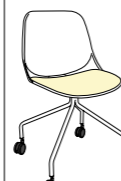

H Ht 79 seduta
L W 70 seat
P Dpt 70 H Ht 45,5

Colori struttura:
Structure colours:
K28F K29K K30N K31T
Rivestimento seduta imbottita
Cushion cover
Z86Y Z87B

COD. VF35.69E

RUNNER

Con ruote e girevole
With wheels and swivel



Elevazione a gas. Scocca in polipropilene termoformato. Struttura e ruote colore grigio.
Pneumatic suspension. Thermoformed polypropylene shell. Structure and wheels in grey colour.

H Ht 77+90 seduta
L W 44 seat
P Dpt 50 H Ht 42+55

Colori disponibili:
Available colours:
Z75N Z76R Z77U Z78X

COD. VF32.72B

GIROTONDO

Con ruote e girevole
With wheels and swivel



Elevazione meccanica. Fondino in tessuto. Struttura in metallo.
Mechanical lift system. Seat covered with fabric. Metal structure.

H Ht 93 seduta
L W 55 seat
P Dpt 55 H Ht 45,3+60

Colori struttura:
Structure colours:
B17A GL4R PP7H ML4B LV5T
CQ3Q GZ8T AL1A
Colore seduta:
Seat colour:
X22K

COD. VF32.75W

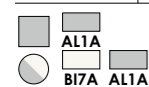

Tavoli DALLAS

DALLAS tables

QUADRATO
Tavoli con piano e telaio in nobilitato e gambe in legno

SQUARE
Tables with laminate top and frame and wooden legs

Colori disponibili:

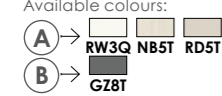

Fisso
Fixed

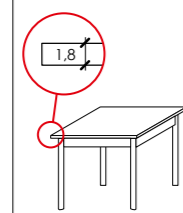

H Ht 77
L W 90
P Dpt 90



Raddoppiabile
Doubling-up

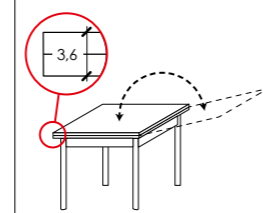

H Ht 78,6
L W 90 (180)
P Dpt 90

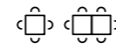

COD. VF35.11A



COD. VF35.12G

RETTANGOLARE
Tavoli con piano e telaio in nobilitato e gambe in legno

RECTANGULAR
Tables with laminate top and frame and wooden legs

Colori disponibili:



Fisso
Fixed

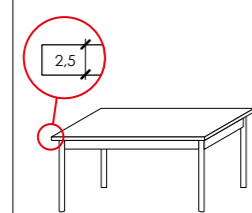

H Ht 77,5
L W 160
P Dpt 85



Allungabile
Extensible

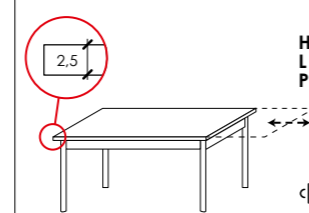

H Ht 77,5
L W 160 (200)
P Dpt 85

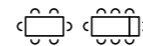

COD. VF35.13P



COD. VF35.14V

Ante Doors

per Armadi ed Elementi sopra-barra

for Wardrobes and
Over-bar elements



Specificare cerniera Sx o Dx
Specify hinge L or R

COD.			H Ht 224 4 cerniere 4 hinges	H Ht 256 4 cerniere 4 hinges
VOLO	(A)		VF30.19F	VF30.20C
WINDOW	(B)		-	-

per Armadi ed Elementi sopra-barra

for Wardrobes and
Over-bar elements



Specificare cerniera Sx o Dx
Specify hinge L or R

COD.		H Ht 32 2 cerniere 2 hinges	H Ht 64 2 cerniere 2 hinges	H Ht 96 2 cerniere 2 hinges	H Ht 128 3 cerniere 3 hinges	H Ht 160 3 cerniere 3 hinges	H Ht 192 4 cerniere 4 hinges	H Ht 224 4 cerniere 4 hinges	H Ht 256 4 cerniere 4 hinges
VOLO	(A)	VF30.30H	VF30.31Q	VF30.32W	VF30.33C	VF30.34K	VF30.35R	VF30.36X	VF30.37D
WINDOW	(B)								

per Armadi ed Elementi sopra-barra

for Wardrobes and
Over-bar elements



Specificare cerniera Sx o Dx
Specify hinge L or R

COD.		H Ht 32 2 cerniere 2 hinges	H Ht 64 2 cerniere 2 hinges	H Ht 96 2 cerniere 2 hinges	H Ht 128 3 cerniere 3 hinges	H Ht 160 3 cerniere 3 hinges	H Ht 192 4 cerniere 4 hinges	H Ht 224 4 cerniere 4 hinges	H Ht 256 4 cerniere 4 hinges
VOLO	(A)	VF30.38L	VF30.39S	VF30.40P	VF30.41V	VF30.42B	VF30.43H	VF30.44Q	VF30.45W
WINDOW	(B)								

per Armadi ed Elementi sopra-barra

for Wardrobes and
Over-bar elements



Specificare cerniera Sx o Dx
Specify hinge L or R

COD.		H Ht 32 4 cerniere 4 hinges	H Ht 64 4 cerniere 4 hinges	H Ht 96 4 cerniere 4 hinges	H Ht 128 6 cerniere 6 hinges	H Ht 160 6 cerniere 6 hinges	H Ht 192 8 cerniere 8 hinges	H Ht 224 8 cerniere 8 hinges	H Ht 256 8 cerniere 8 hinges
VOLO	(A)	VF30.46C	VF30.47K	VF30.48R	VF30.49X	VF30.50U	VF30.51A	VF30.52G	VF30.53P
WINDOW	(B)								



per Angoli interi for Corner wardrobes

Coppia ante Pair of doors

COD.		H Ht 224 8 cerniere 8 hinges	H Ht 256 8 cerniere 8 hinges
VOLO	(A)	VF30.54V	VF30.55B
	(B)		

per Armadi for Wardrobes

Ante specchio (dotate di pomello SEM)
La fascia prezzo è determinata dalla finitura del pannello sul quale viene applicato lo specchio
Mirror doors (equipped with SEM knob)
The price range is determined by the finish of the panel on which the mirror is applied



Specificare cerniera Sx o Dx
Specify hinge L or R

COD.		H Ht 224 4 cerniere 4 hinges	H Ht 256 4 cerniere 4 hinges
VOLO	(A)	VF30.21K	VF30.22R
	(B)		

per Armadi for Wardrobes

Ante specchio (dotate di pomello SEM)
La fascia prezzo è determinata dalla finitura del pannello sul quale viene applicato lo specchio
Mirror doors (equipped with SEM knob)
The price range is determined by the finish of the panel on which the mirror is applied



Specificare cerniera Sx o Dx
Specify hinge L or R

COD.		H Ht 224 6 cerniere 6 hinges	H Ht 256 6 cerniere 6 hinges
VOLO	(A)	VF30.23X	VF30.24D
	(B)		

per Armadi for Wardrobes

Ante specchio (dotate di pomello SEM)
La fascia prezzo è determinata dalla finitura del pannello sul quale viene applicato lo specchio
Mirror doors (equipped with SEM knob)
The price range is determined by the finish of the panel on which the mirror is applied



COD.		H Ht 224 8 cerniere 8 hinges	H Ht 256 8 cerniere 8 hinges
VOLO	(A)	VF30.25L	VF30.26S
	(B)		

Sovrapprezzi per rallentatore chiusura:
Surcharge for closing retainer:

ANTA (No su ante per angolo)
DOOR (No on the doors for corner units)

pag. 42

Posizionamento pomelli e maniglie
Knobs and handles position

Ante Doors

per Pensili
for Hanging units

L
W **30**

Specificare cerniera Sx o Dx
Specify hinge L or R

COD.	VF30.27Y	VF30.68B	VF30.69H	VF30.28E
VOLO	(A)	(B)		
WINDOW				

Ante
Doors

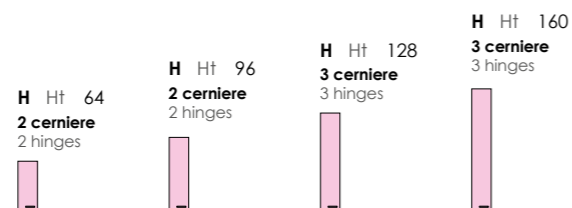

per Componibili e Pensili
for Modular units and Hanging units

L
W **45**

Specificare cerniera Sx o Dx
Specify hinge L or R

COD.	VF30.56H	VF30.57Q	VF30.58W	VF30.59C	VF30.29M
VOLO	(A)	(B)			
WINDOW					

Ante
Doors

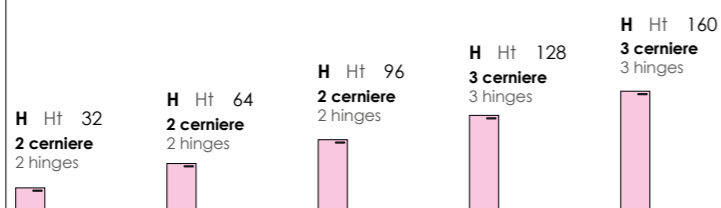

per Componibili e Pensili
for Modular units and Hanging units

L
W **60**

Specificare cerniera Sx o Dx
Specify hinge L or R

COD.	VF30.60Z	VF30.61F	VF30.62N	VF30.63U
VOLO	(A)	(B)		
WINDOW				

Ante
Doors

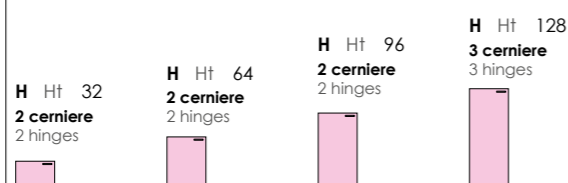

per Componibili e Pensili
for Modular units and Hanging units

L
W **90**

Specificare cerniera Sx o Dx
Specify hinge L or R

COD.	VF30.64A	VF30.65G	VF30.66P	VF30.67V
VOLO	(A)	(B)		
WINDOW				

Coppia ante
Pair of doors

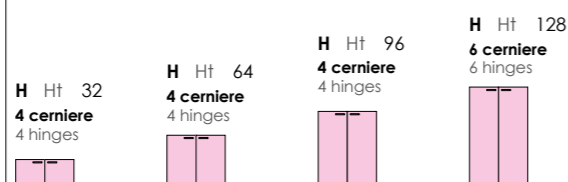

Cassetti e cassettoni VOLO VOLO drawers and big drawers

per Armadi P 56,3
for Wardrobes Dpt 56.3

P
Dpt **51,8**

L W	45	COD.	VF30.70E	VF30.71M	VF30.72T	VF30.73Z	VF30.74F
		VOLO	(A)	(B)			
L W	60	COD.	VF30.75N	VF30.76U	VF30.77A	VF30.78G	VF30.79P
		VOLO	(A)	(B)			
L W	90	COD.	VF30.80L	VF30.81S	VF30.82Y	VF30.83E	VF30.84M
		VOLO	(A)	(B)			
			45,00	90,00	180,00	64,00	128,00
			58,00	115,00	230,00	80,00	160,00

Cassetti H 16
Drawers Ht 16

Cassettoni H 32
Big drawers Ht 32

per Componibili P 45,8
for Modular units Dpt 45.8

P
Dpt **41,8**

L W	45	COD.	VF30.85T	VF30.86Z	VF30.87F	VF30.88N	VF30.89U
		VOLO	(A)	(B)			
L W	60	COD.	VF30.90R	VF30.91X	VF30.92D	VF30.93L	VF30.94S
		VOLO	(A)	(B)			
L W	90	COD.	VF30.95Y	VF30.96E	VF30.97M	VF30.98T	VF30.99Z
		VOLO	(A)	(B)			

Cassetti H 16
Drawers Ht 16

Cassettoni H 32
Big drawers Ht 32

Sovrapprezzi per cassetti/cassettoni P 45,8 con guide tipo "Quadro":
Surcharge for Dpt 45.8 drawers/big drawers with type "Quadro" metal runners:

RALLENTATE / PUSH-PULL
SLOWED DOWN / PUSH-PULL

Sovrapprezzi per rallentatore chiusura:
Surcharge for closing retainer:

ANTA
DOOR
CASSETTO / CASSETTONE
DRAWER / BIG DRAWER

pag. 42

Posizionamento pomelli e maniglie
Knobs and handles position

Pannello anta VOLO senza fori cerniera e maniglia

VOLO door panel without hinge and handle holes

Sp
Th **1,8**

In fase d'ordine specificare
altezza (H) e larghezza (L)
del pannello anta

When making the order specify
height (Ht) and width (W) of the
door panel

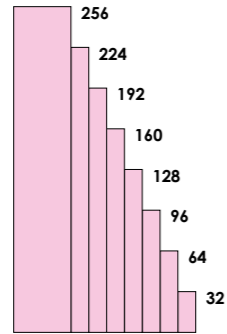

COD.		VF31.01C					
		L W 29,7 (30)		L W 44,7 (45)		L W 59,7 (60)	
H	Ht 31,6 (32)	<input type="radio"/> A					
		<input type="radio"/> B					
H	Ht 63,6 (64)	<input type="radio"/> A					
		<input type="radio"/> B					
H	Ht 95,6 (96)	<input type="radio"/> A					
		<input type="radio"/> B					
H	Ht 127,6 (128)	<input type="radio"/> A					
		<input type="radio"/> B					
H	Ht 159,6 (160)	<input type="radio"/> A					
		<input type="radio"/> B					
H	Ht 191,6 (192)	<input type="radio"/> A					
		<input type="radio"/> B					
H	Ht 223,6 (224)	<input type="radio"/> A					
		<input type="radio"/> B					
H	Ht 255,6 (256)	<input type="radio"/> A					
		<input type="radio"/> B					

Finiture GRUPPO 1
GROUP 1 finishes

Facciate Fronts
VOLO

Finiture GRUPPO 2
GROUP 2 finishes

Rovere white*

<div style="border: 1px solid #ccc; padding: 5px; margin-bottom: 5px;"> A ★ </div> <p style="font-size: 0.8em; margin: 0;">Rovere white RW3Q</p>	<div style="border: 1px solid #ccc; padding: 5px; margin-bottom: 5px;"> A ★ </div> <p style="font-size: 0.8em; margin: 0;">Noce brina NB5T</p>	<div style="border: 1px solid #ccc; padding: 5px; margin-bottom: 5px;"> A </div> <p style="font-size: 0.8em; margin: 0;">Bianco opaco BI7A</p>	<div style="border: 1px solid #ccc; padding: 5px; margin-bottom: 5px;"> A </div> <p style="font-size: 0.8em; margin: 0;">Grigio Dorian GL4R</p>	<div style="border: 1px solid #ccc; padding: 5px; margin-bottom: 5px;"> B ★ </div> <p style="font-size: 0.8em; margin: 0;">Cemento artico CA7A</p>	<div style="border: 1px solid #ccc; padding: 5px; margin-bottom: 5px;"> B ★ </div> <p style="font-size: 0.8em; margin: 0;">Rovere gesso RG9L</p>
<div style="border: 1px solid #ccc; padding: 5px; margin-bottom: 5px;"> B ★ </div> <p style="font-size: 0.8em; margin: 0;">Royal oak RS4B</p>	<div style="border: 1px solid #ccc; padding: 5px; margin-bottom: 5px;"> B ★ </div> <p style="font-size: 0.8em; margin: 0;">Rovere cognac RC3Q</p>	<div style="border: 1px solid #ccc; padding: 5px; margin-bottom: 5px;"> B </div> <p style="font-size: 0.8em; margin: 0;">Grigio titanio GZ8T</p>			
<div style="border: 1px solid #ccc; padding: 5px; margin-bottom: 5px;"> B </div> <p style="font-size: 0.8em; margin: 0;">Papaya PP7H</p>	<div style="border: 1px solid #ccc; padding: 5px; margin-bottom: 5px;"> B </div> <p style="font-size: 0.8em; margin: 0;">Miele ML4B</p>	<div style="border: 1px solid #ccc; padding: 5px; margin-bottom: 5px;"> B </div> <p style="font-size: 0.8em; margin: 0;">Oliva LV5T</p>	<div style="border: 1px solid #ccc; padding: 5px; margin-bottom: 5px;"> B </div> <p style="font-size: 0.8em; margin: 0;">Cadaques CQ3Q</p>		

Vetri
Glass

Ante Doors
WINDOW

<div style="border: 1px solid #ccc; padding: 5px; margin-bottom: 5px;"> A </div> <p style="font-size: 0.8em; margin: 0;">Trasparente TR9M</p>	<div style="border: 1px solid #ccc; padding: 5px; margin-bottom: 5px;"> A </div> <p style="font-size: 0.8em; margin: 0;">Trasparente fumé FT8P</p>	<div style="border: 1px solid #ccc; padding: 5px; margin-bottom: 5px;"> A </div> <p style="font-size: 0.8em; margin: 0;">Stop sol ST6P</p>	<div style="border: 1px solid #ccc; padding: 5px; margin-bottom: 5px;"> A </div> <p style="font-size: 0.8em; margin: 0;">Specchio SP7L</p>	<div style="border: 1px solid #ccc; padding: 5px; margin-bottom: 5px;"> A </div> <p style="font-size: 0.8em; margin: 0;">Alluminio AL1A</p>	<div style="border: 1px solid #ccc; padding: 5px; margin-bottom: 5px;"> A </div> <p style="font-size: 0.8em; margin: 0;">Titan grey TG7H</p>
---	--	--	--	---	--

Colori telaio
Frame colours

<div style="border: 1px solid #ccc; padding: 5px; margin-bottom: 5px;"> A </div> <p style="font-size: 0.8em; margin: 0;">Alluminio AL1A</p>	<div style="border: 1px solid #ccc; padding: 5px; margin-bottom: 5px;"> A </div> <p style="font-size: 0.8em; margin: 0;">Titan grey TG7H</p>
---	--

ARMADI CON ANTE BATTENTI E SCORREVOLI WARDROBES WITH HINGED AND SLIDING DOORS

Armadi con ante battenti - H 225,6 P 56,3	pag. 62
Wardrobes with hinged doors - Ht 225.6 Dpt 56.3	
Armadi con ante battenti - H 257,6 P 56,3	pag. 68
Wardrobes with hinged doors - Ht 257.6 Dpt 56.3	
Armadi porta TV con ante battenti - P 56,3	pag. 74
TV wardrobes with hinged doors - Dpt 56.3	
Elementi JOLLY	pag. 75
JOLLY elements	
Accessori per armadi con ante battenti	pag. 76
Wardrobes with hinged doors accessories	
Cabine ad angolo ELLE	pag. 78
ELLE corner walk-in wardrobes	
Cabine ad angolo ESSE	pag. 80
ESSE corner walk-in wardrobes	
Cabine ad angolo EFFE	pag. 82
EFFE corner walk-in wardrobes	
Angoli interi per armadi - P 56,3	pag. 84
Corner wardrobes - Dpt 56.3	
Terminali - P 56,3	pag. 85
End units - Dpt 56.3	
Librerie terminali ORDER - L 32,5 P 54,5 - con contenitore L 30 P 32,5	pag. 86
ORDER end bookshelves - W 32.5 Dpt 54.5 - with cabinet W 30 Dpt 32.5	
Librerie terminali OLA - L 30,7 P 53,6	pag. 87
OLA end bookshelves - W 30.7 Dpt 53.6	
Librerie terminali SLASH - L 26 P 54,5 - con porta scarpe	pag. 88
SLASH end bookshelves - W 26 Dpt 54.5 - with shoe rack	
Librerie terminali PILL - L 26 P 50,9	pag. 89
PILL end bookshelves - W 26 Dpt 50.9	
Armadi con ante scorrevoli FREE - H 225,3 P 61,5	pag. 90
Wardrobes with FREE sliding doors - Ht 225.3 Dpt 61.5	
Armadi con ante scorrevoli FREE - H 257,3 P 61,5	pag. 92
Wardrobes with FREE sliding doors - Ht 257.3 Dpt 61.5	
Accessori per armadi con ante scorrevoli	pag. 94
Wardrobes with sliding doors accessories	
Fasce di tamponamento	pag. 96
Filler strips	

Rovere white* Finitura unica per tutti i componenti in pannello presenti a listino non evidenziati con il colore Finiture GRUPPO 1 e/o Finiture GRUPPO 2.
Unique finish for all the panel components shown in the pricelist not highlighted with the color finishes GROUP 1 and/or finishes GROUP 2.

- A Finiture in fascia di prezzo A
Finishes in price range A
- B Finiture in fascia di prezzo B
Finishes in price range B
- ★ Finiture con effetto materico
Finishes with textured effect

Armadi con ante battenti - H 225,6 P 56,3

Wardrobes with hinged doors - Ht 225.6 Dpt 56.3



- Sono compresi i ripiani interni indicati con il tratteggio.
- 1 tubo appendiabiti è situato in corrispondenza delle ante H 96 - 128 - 160 - 192.
- 2 tubi appendiabiti sono situati in corrispondenza delle ante H 224.
- Sono dotati di piedini regolabili.

- Inner shelves included, indicated by the dotted line.
- With Ht 96 - 128 - 160 - 192 doors 1 clothes hanging rail is included.
- With Ht 224 doors 2 clothes hanging rails are included.
- They are equipped with adjustable feet.

Fianco finale
End panel
H Ht 225,6
P Dpt 54,5
Sp Th 1,8

L
W 30

Specificare
cerniera Sx o Dx
Specify hinge
L or R

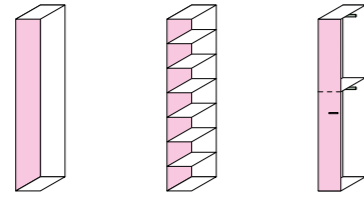

COD. VF00.90F VF00.91N VF00.92U

VOLO A B

WINDOW A B

VF00.99Q

L
W 45

Specificare
cerniera Sx o Dx
Specify hinge
L or R



COD. VF00.00G VF00.01P VF00.02V VF00.93A VF00.03B VF00.04H VF00.05Q VF00.06W VF00.07C VF00.08K VF00.09R VF00.10N VF00.11U VF00.12A VF00.13G VF00.14P

VOLO A B

WINDOW A B

Anta specchio
Mirror door

L
W 60

Specificare
cerniera Sx o Dx
Specify hinge
L or R



COD. VF00.15V VF00.16B VF00.17H VF00.94G VF00.18Q VF00.19W VF00.20T VF00.21Z VF00.22F VF00.23N VF00.24U VF00.25A VF00.26G VF00.27P VF00.28V VF00.29B

VOLO A B

WINDOW A B

Anta specchio
Mirror door

L
W 90

Specificare
cerniera Sx o Dx
Specify hinge
L or R

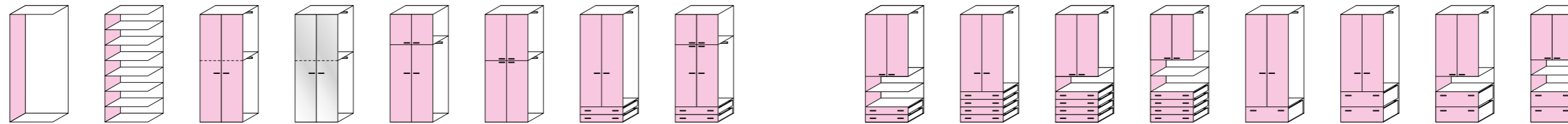

COD. VF00.30Y VF00.31E VF00.32M VF00.95P VF00.33T VF00.34Z VF00.35F VF00.36N VF00.37U VF00.38A VF00.39G VF00.40D VF00.41L VF00.42S VF00.43Y VF00.44E

VOLO A B

WINDOW A B

Anta specchio
Mirror doors



Sovrapprezzi:
Surcharge:

Per ripiano interno Sp 3,5
For inner shelf Th 3.5

Sovrapprezzi per rallentatore chiusura:
Surcharge for closing retainer:

ANTA
DOOR
CASSETTO / CASSETONE
DRAWER / BIG DRAWER

pag. 42
pag. 76
pag. 85
pag. 96

Posizionamento pomelli e maniglie
Knobs and handles position
Accessori per armadi con ante battenti
Wardrobes with hinged doors accessories
Elementi terminali
End elements
Fasce di tamponamento
Filler strips

Armadi con ante battenti - H 225,6 P 56,3

Wardrobes with hinged doors - Ht 225.6 Dpt 56.3



- Sono compresi i ripiani interni indicati con il tratteggio.
- 1 tubo appendiabiti è situato in corrispondenza delle ante H 96 - 128 - 160 - 192.
- 2 tubi appendiabiti sono situati in corrispondenza delle ante H 224.
- Sono dotati di piedini regolabili.

- Inner shelves included, indicated by the dotted line.
- With Ht 96 - 128 - 160 - 192 doors 1 clothes hanging rail is included.
- With Ht 224 doors 2 clothes hanging rails are included.
- They are equipped with adjustable feet.

L
W 121,8

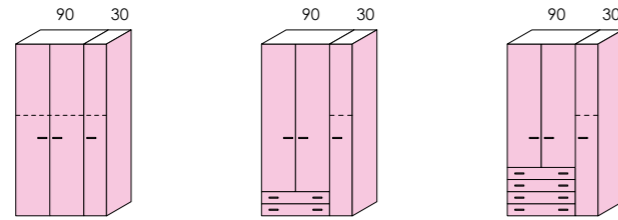

COD.	VF00.96V	VF00.97B	VF00.98H
VOLO	(A)	(B)	
WINDOW	(A)	(B)	

L
W 136,8

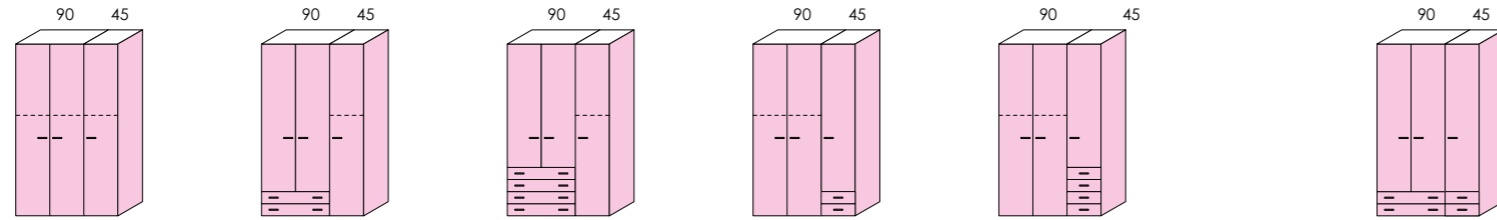

COD.	VF00.45M	VF00.46T	VF00.47Z	VF00.48F	VF00.49N	VF00.50K
VOLO	(A)	(B)				
WINDOW	(A)	(B)				

L
W 151,8

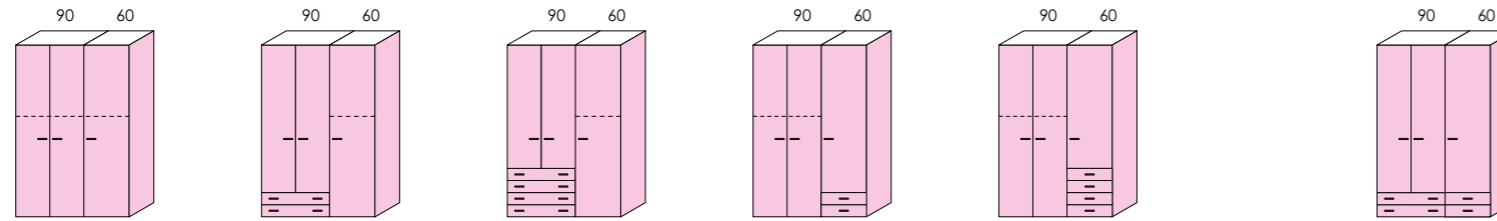

COD.	VF00.51R	VF00.52X	VF00.53D	VF00.54L	VF00.55S	VF00.56Y
VOLO	(A)	(B)				
WINDOW	(A)	(B)				

L
W 181,8

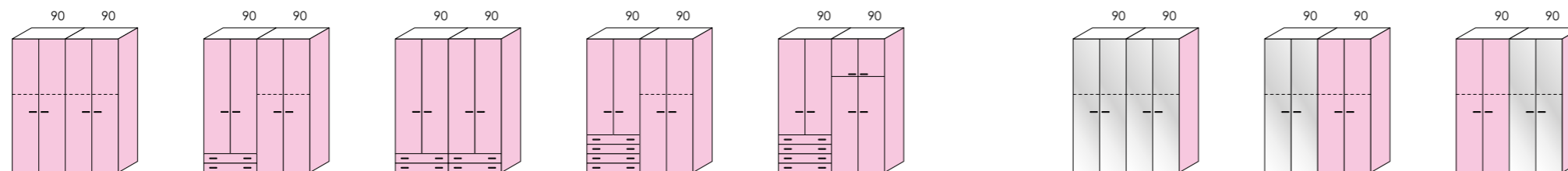

COD.	VF00.57E	VF00.58M	VF00.59T	VF00.60Q	VF00.61W	VF01.96Z	VF01.97F	VF01.98N
VOLO	(A)	(B)						
WINDOW	(A)	(B)						



Sovrapprezzi:
Surcharge:
Per ripiano interno Sp 3,5
For inner shelf Th 3.5

Sovrapprezzi per rallentatore chiusura:
Surcharge for closing retainer:
ANTA
DOOR
CASSETTO / CASSETONE
DRAWER / BIG DRAWER

pag. 42
pag. 76
pag. 85
pag. 96

Posizionamento pomelli e maniglie
Knobs and handles position
Accessori per armadi con ante battenti
Wardrobes with hinged doors accessories
Elementi terminali
End elements
Fasce di tamponamento
Filler strips

Armadi con ante battenti - H 225,6 P 56,3

Wardrobes with hinged doors - Ht 225.6 Dpt 56.3

- Sono compresi i ripiani interni indicati con il tratteggio.
- 1 tubo appendiabiti è situato in corrispondenza delle ante H 96 - 128 - 160 - 192.
- 2 tubi appendiabiti sono situati in corrispondenza delle ante H 224.
- Sono dotati di piedini regolabili.

- Inner shelves included, indicated by the dotted line.
- With Ht 96 - 128 - 160 - 192 doors 1 clothes hanging rail is included.
- With Ht 224 doors 2 clothes hanging rails are included.
- They are equipped with adjustable feet.

L
W 211,8

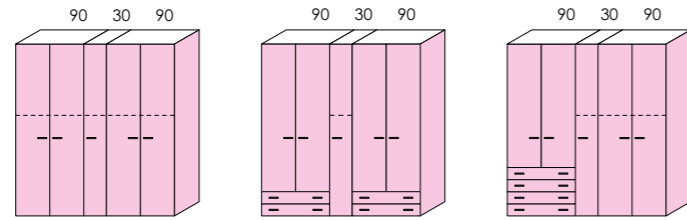

COD.	VF01.85N	VF01.86U	VF01.87A
VOLO	<input type="radio"/> A	<input type="radio"/> B	<input type="radio"/> B
WINDOW	<input type="radio"/> A	<input type="radio"/> B	<input type="radio"/> B

L
W 226,8

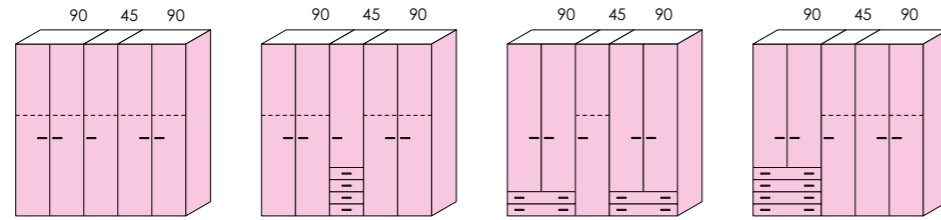

COD.	VF00.62C	VF00.63K	VF00.64R	VF00.65X
VOLO	<input type="radio"/> A	<input type="radio"/> B	<input type="radio"/> B	<input type="radio"/> B
WINDOW	<input type="radio"/> A	<input type="radio"/> B	<input type="radio"/> B	<input type="radio"/> B

L
W 241,8

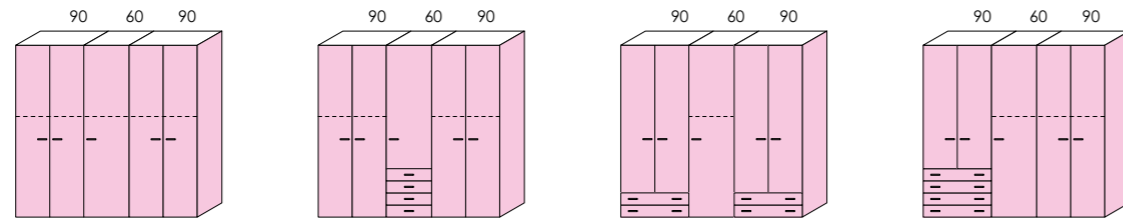

COD.	VF00.66D	VF00.67L	VF00.68S	VF00.69Y
VOLO	<input type="radio"/> A	<input type="radio"/> B	<input type="radio"/> B	<input type="radio"/> B
WINDOW	<input type="radio"/> A	<input type="radio"/> B	<input type="radio"/> B	<input type="radio"/> B

L
W 271,8

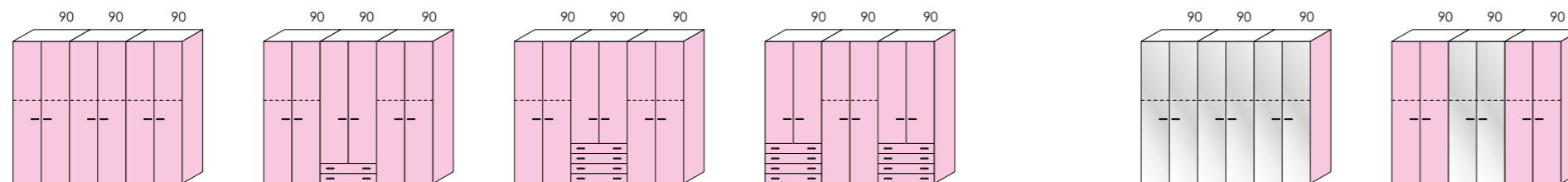

COD.	VF00.70V	VF00.71B	VF00.72H	VF00.73Q	VF01.88G	VF01.89P
VOLO	<input type="radio"/> A	<input type="radio"/> B	<input type="radio"/> B	<input type="radio"/> B	<input type="radio"/> B	<input type="radio"/> B
WINDOW	<input type="radio"/> A	<input type="radio"/> B	<input type="radio"/> B	<input type="radio"/> B	<input type="radio"/> B	<input type="radio"/> B



Sovrapprezzi:
Surcharge:
Per ripiano interno Sp 3,5
For inner shelf Th 3.5

Sovrapprezzi per rallentatore chiusura:
Surcharge for closing retainer:
ANTA
DOOR
CASSETTO / CASSETONE
DRAWER / BIG DRAWER

pag. 42
pag. 76
pag. 85
pag. 96

Posizionamento pomelli e maniglie
Knobs and handles position
Accessori per armadi con ante battenti
Wardrobes with hinged doors accessories
Elementi terminali
End elements
Fasce di tamponamento
Filler strips

Armadi con ante battenti - H 257,6 P 56,3

Wardrobes with hinged doors - Ht 257.6 Dpt 56.3



- Sono compresi i ripiani interni indicati con il tratteggio.
- 1 tubo appendiabiti è situato in corrispondenza delle ante H 96 - 128 - 160 - 192.
- 2 tubi appendiabiti sono situati in corrispondenza delle ante H 224 - 256.
- Sono dotati di piedini regolabili.

- Inner shelves included, indicated by the dotted line.
- With Ht 96 - 128 - 160 - 192 doors 1 clothes hanging rail is included.
- With Ht 224 - 256 doors 2 clothes hanging rails are included.
- They are equipped with adjustable feet.

Fianco finale
End panel
H Ht 257,6
P Dpt 54,5
Sp Th 1,8

L
W 30

Specificare
cerniera Sx o Dx
Specify hinge
L or R

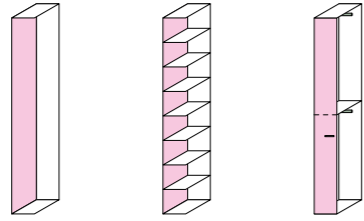

COD. VF01.90L VF01.91S VF01.92Y

VOLO A B

WINDOW A B

VF01.99U

L
W 45

Specificare
cerniera Sx o Dx
Specify hinge
L or R



COD. VF01.00M VF01.01T VF01.02Z VF01.93E VF01.03F VF01.04N VF01.05U VF01.06A VF01.07G VF01.08P VF01.09V VF01.10S VF01.11Y VF01.12E VF01.13M VF01.14T

VOLO A B

WINDOW A B

L
W 60

Specificare
cerniera Sx o Dx
Specify hinge
L or R

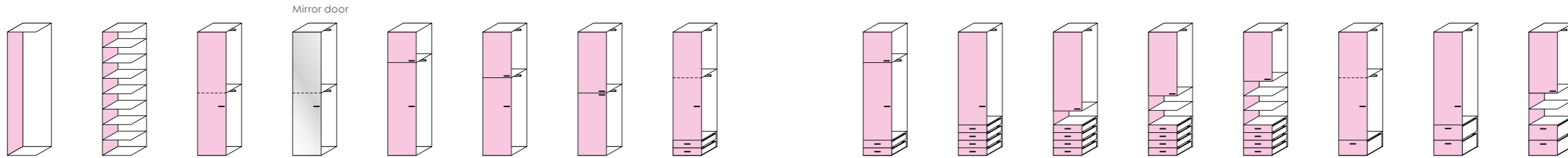

COD. VF01.15Z VF01.16F VF01.17N VF01.94M VF01.18U VF01.19A VF01.20X VF01.21D VF01.22L VF01.23S VF01.24Y VF01.25E VF01.26M VF01.27T VF01.28Z VF01.29F

VOLO A B

WINDOW A B

L
W 90

Specificare
cerniera Sx o Dx
Specify hinge
L or R

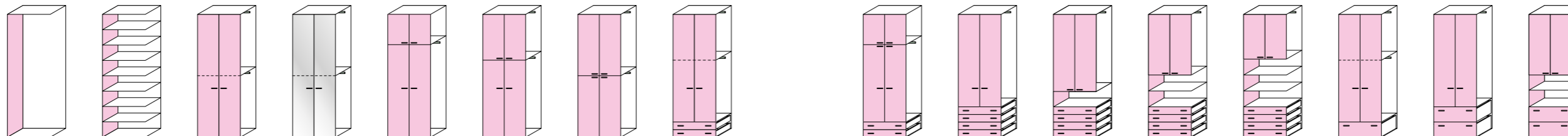

COD. VF01.30C VF01.31K VF01.32R VF01.95T VF01.33X VF01.34D VF01.35L VF01.36S VF01.37Y VF01.38E VF01.39M VF01.40H VF01.41Q VF01.42W VF01.43C VF01.44K

VOLO A B

WINDOW A B



Sovrapprezzi:
Surcharge:

Per ripiano interno Sp 3,5
For inner shelf Th 3.5

Sovrapprezzi per rallentatore chiusura:
Surcharge for closing retainer:

ANTA
DOOR
CASSETTO / CASSETONE
DRAWER / BIG DRAWER

pag. 42
pag. 76
pag. 85
pag. 96

Posizionamento pomelli e maniglie
Knobs and handles position
Accessori per armadi con ante battenti
Wardrobes with hinged doors accessories
Elementi terminali
End elements
Fasce di tamponamento
Filler strips

Armadi con ante battenti - H 257,6 P 56,3

Wardrobes with hinged doors - Ht 257.6 Dpt 56.3



- Sono compresi i ripiani interni indicati con il tratteggio.
- 1 tubo appendiabiti è situato in corrispondenza delle ante H 96 - 128 - 160 - 192.
- 2 tubi appendiabiti sono situati in corrispondenza delle ante H 224 - 256.
- Sono dotati di piedini regolabili.

- Inner shelves included, indicated by the dotted line.
- With Ht 96 - 128 - 160 - 192 doors 1 clothes hanging rail is included.
- With Ht 224 - 256 doors 2 clothes hanging rails are included.
- They are equipped with adjustable feet.

L
W 121,8

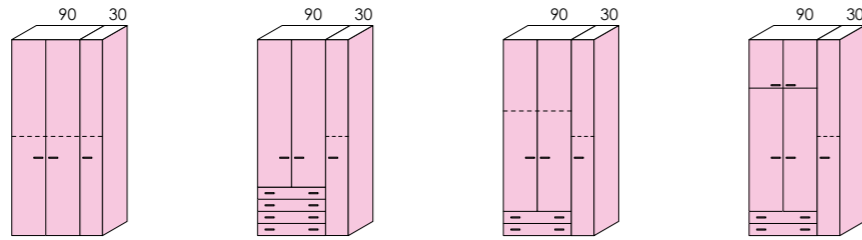

COD.	VF02.02D	VF02.03L	VF02.04S	VF02.05Y
VOLO	<input type="radio"/> A	<input type="radio"/> B	<input type="radio"/> A	<input type="radio"/> B
WINDOW	<input type="radio"/> A	<input type="radio"/> B	<input type="radio"/> A	<input type="radio"/> B

L
W 136,8

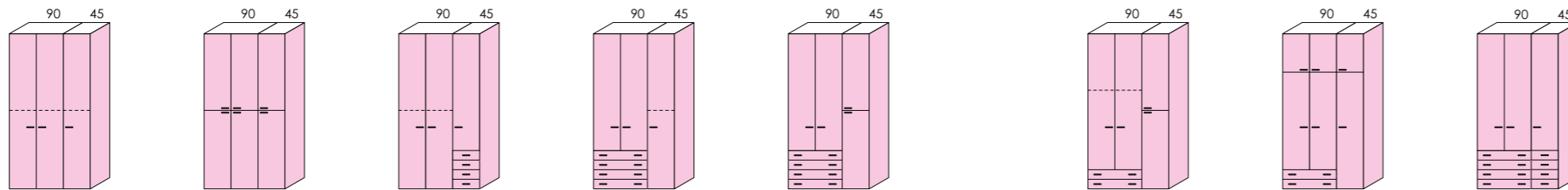

COD.	VF01.45R	VF01.46X	VF01.47D	VF01.48L	VF01.49S	VF01.50P	VF01.51V	VF01.52B
VOLO	<input type="radio"/> A	<input type="radio"/> B	<input type="radio"/> A	<input type="radio"/> B	<input type="radio"/> A	<input type="radio"/> B	<input type="radio"/> A	<input type="radio"/> B
WINDOW	<input type="radio"/> A	<input type="radio"/> B	<input type="radio"/> A	<input type="radio"/> B	<input type="radio"/> A	<input type="radio"/> B	<input type="radio"/> A	<input type="radio"/> B

L
W 151,8

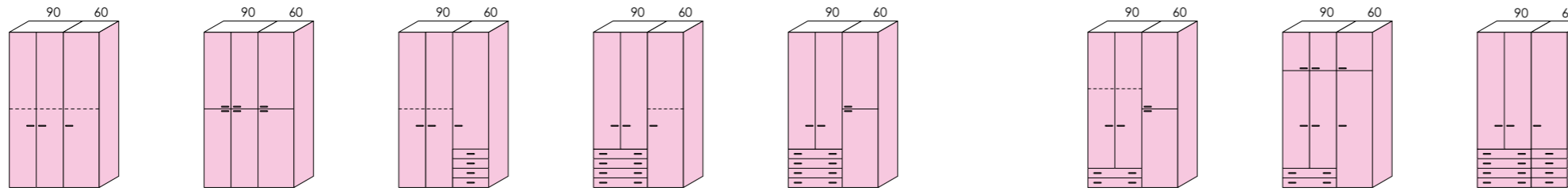

COD.	VF01.53H	VF01.54Q	VF01.55W	VF01.56C	VF01.57K	VF01.58R	VF01.59X	VF01.60U
VOLO	<input type="radio"/> A	<input type="radio"/> B	<input type="radio"/> A	<input type="radio"/> B	<input type="radio"/> A	<input type="radio"/> B	<input type="radio"/> A	<input type="radio"/> B
WINDOW	<input type="radio"/> A	<input type="radio"/> B	<input type="radio"/> A	<input type="radio"/> B	<input type="radio"/> A	<input type="radio"/> B	<input type="radio"/> A	<input type="radio"/> B

L
W 181,8

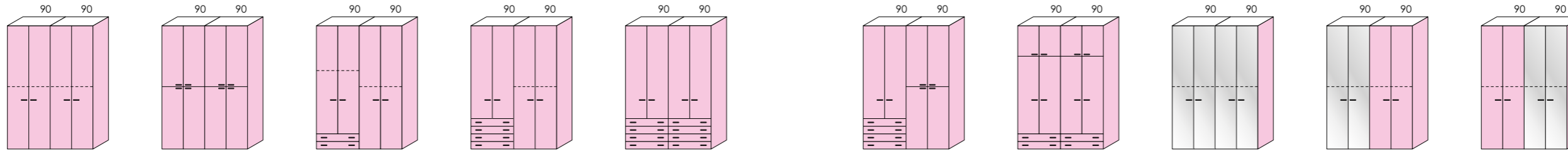

COD.	VF01.61A	VF01.62G	VF01.63P	VF01.64V	VF01.65B	VF01.66H	VF01.67Q	VF02.06E	VF02.07M	VF02.08T
VOLO	<input type="radio"/> A	<input type="radio"/> B	<input type="radio"/> A	<input type="radio"/> B	<input type="radio"/> A	<input type="radio"/> B	<input type="radio"/> A	<input type="radio"/> B	<input type="radio"/> A	<input type="radio"/> B
WINDOW	<input type="radio"/> A	<input type="radio"/> B	<input type="radio"/> A	<input type="radio"/> B	<input type="radio"/> A	<input type="radio"/> B	<input type="radio"/> A	<input type="radio"/> B	<input type="radio"/> A	<input type="radio"/> B



Sovrapprezzi:
Surcharge:
Per ripiano interno Sp 3,5
For inner shelf Th 3.5

Sovrapprezzi per rallentatore chiusura:
Surcharge for closing retainer:
ANTA
DOOR
CASSETTO / CASSETONE
DRAWER / BIG DRAWER

pag. 42
pag. 76
pag. 85
pag. 96

Posizionamento pomelli e maniglie
Knobs and handles position
Accessori per armadi con ante battenti
Wardrobes with hinged doors accessories
Elementi terminali
End elements
Fasce di tamponamento
Filler strips

Armadi con ante battenti - H 257,6 P 56,3

Wardrobes with hinged doors - Ht 257.6 Dpt 56.3

- Sono compresi i ripiani interni indicati con il tratteggio.
- 1 tubo appendiabiti è situato in corrispondenza delle ante H 96 - 128 - 160 - 192.
- 2 tubi appendiabiti sono situati in corrispondenza delle ante H 224 - 256.
- Sono dotati di piedini regolabili.

- Inner shelves included, indicated by the dotted line.
- With Ht 96 - 128 - 160 - 192 doors 1 clothes hanging rail is included.
- With Ht 224 - 256 doors 2 clothes hanging rails are included.
- They are equipped with adjustable feet.

L
W 211,8

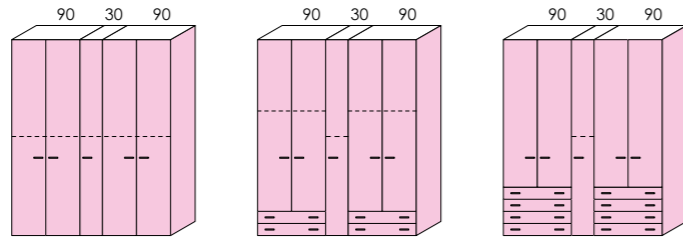

COD.	VF02.12K	VF02.13R	VF02.14X
VOLO	<input type="radio"/> A	<input type="radio"/> B	<input type="radio"/> B
WINDOW	<input type="radio"/> A	<input type="radio"/> B	<input type="radio"/> B

L
W 226,8

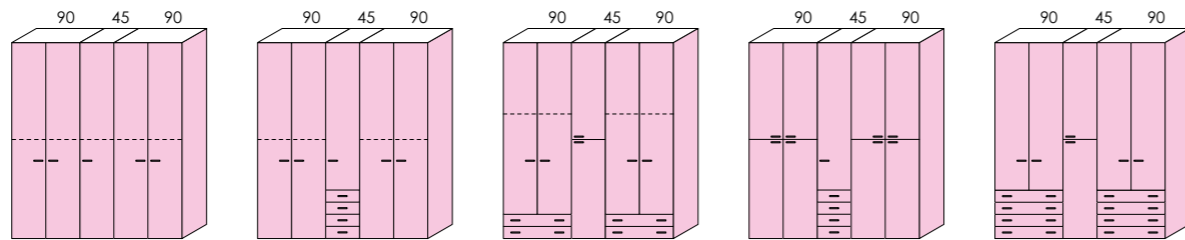

COD.	VF01.68W	VF01.69C	VF01.70Z	VF01.71F	VF01.72N
VOLO	<input type="radio"/> A	<input type="radio"/> B	<input type="radio"/> B	<input type="radio"/> B	<input type="radio"/> B
WINDOW	<input type="radio"/> A	<input type="radio"/> B	<input type="radio"/> B	<input type="radio"/> B	<input type="radio"/> B

L
W 241,8

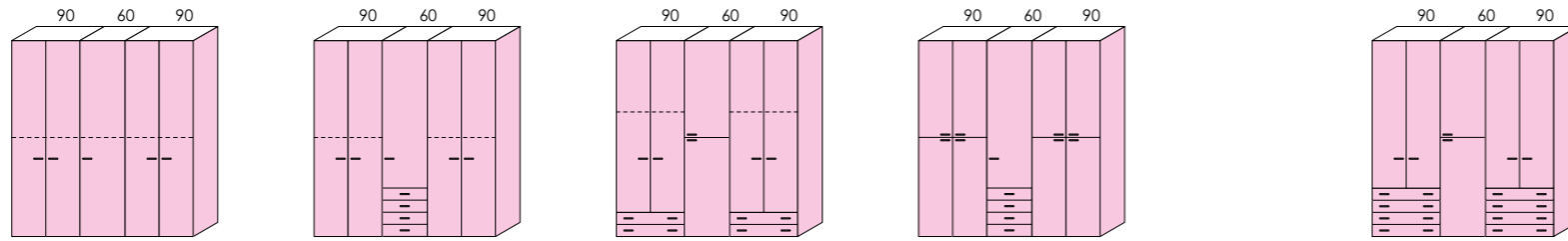

COD.	VF01.73U	VF01.74A	VF01.75G	VF01.76P	VF01.77V
VOLO	<input type="radio"/> A	<input type="radio"/> B	<input type="radio"/> B	<input type="radio"/> B	<input type="radio"/> B
WINDOW	<input type="radio"/> A	<input type="radio"/> B	<input type="radio"/> B	<input type="radio"/> B	<input type="radio"/> B

L
W 271,8

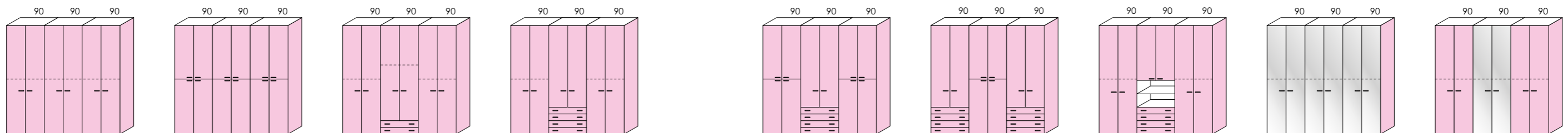

COD.	VF01.78B	VF01.79H	VF01.80E	VF01.81M	VF01.82T	VF01.83Z	VF01.84F	VF02.17S	VF02.18Y
VOLO	<input type="radio"/> A	<input type="radio"/> B	<input type="radio"/> B	<input type="radio"/> B	<input type="radio"/> B	<input type="radio"/> B	<input type="radio"/> B	<input type="radio"/> B	<input type="radio"/> B
WINDOW	<input type="radio"/> A	<input type="radio"/> B	<input type="radio"/> B	<input type="radio"/> B	<input type="radio"/> B	<input type="radio"/> B	<input type="radio"/> B	<input type="radio"/> B	<input type="radio"/> B



Sovrapprezzi:
Surcharge:
Per ripiano interno Sp 3,5
For inner shelf Th 3.5

Sovrapprezzi per rallentatore chiusura:
Surcharge for closing retainer:
ANTA
DOOR
CASSETTO / CASSETONE
DRAWER / BIG DRAWER

pag. 42
pag. 76
pag. 85
pag. 96

Posizionamento pomelli e maniglie
Knobs and handles position
Accessori per armadi con ante battenti
Wardrobes with hinged doors accessories
Elementi terminali
End elements
Fasce di tamponamento
Filler strips

Armadi porta TV con ante battenti - P 56,3

TV wardrobes with hinged doors - Dpt 56.3

- Sono compresi i ripiani interni indicati con il tratteggio.
- 1 tubo appendiabiti è situato in corrispondenza delle ante H 96.
- Sono dotati di piedini regolabili.

- Inner shelves included, indicated by the dotted line.
- With Ht 96 doors 1 clothes hanging rail is included.
- They are equipped with adjustable feet.

H
Ht 225,6

* Specificare cerniera anta porta tv Sx o Dx (disegno Sx)
Specify L or R tv door hinge (L drawing)

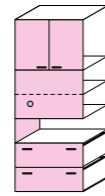
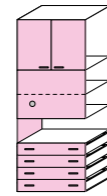
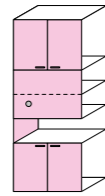
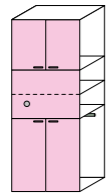

Fianco finale
End panel
H Ht 225,6
P Dpt 54,5
Sp Th 1,8

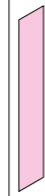

COD. VF02.70D VF02.71L VF02.72S VF02.73Y VF00.99Q

VOLO



H
Ht 257,6

* Specificare cerniera anta porta tv Sx o Dx (disegno Sx)
Specify L or R tv door hinge (L drawing)

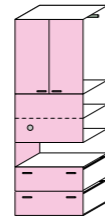
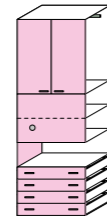
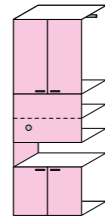
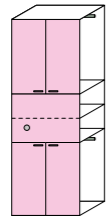

Fianco finale
End panel
H Ht 257,6
P Dpt 54,5
Sp Th 1,8

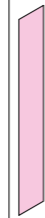

COD. VF02.74E VF02.75M VF02.76T VF02.77Z VF01.99U

VOLO

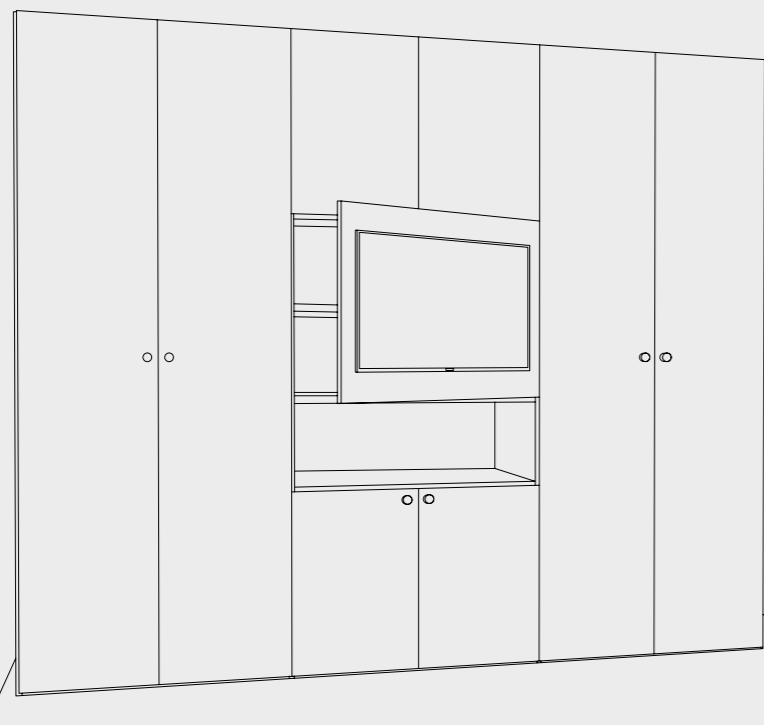

Dimensioni anta porta TV: L 89,7 - H 63,6 - Sp 1,8; portata massima 6 Kg.
L'anta porta tv è dotata di: apertura push-pull, foro passacavi e copriforo Ø 8.
Nelle versioni con vano a giorno è presente 1 copriforo per passacavi Ø 8 aggiuntivo, in modo da consentire il passaggio dei vari cablaggi dal vano a giorno al vano porta tv; il foro sul ripiano è a cura del cliente.

TV door dimension: L 89,7 - H 63,6 - Th 1,8; maximum load capacity 6 Kg.
The TV door is equipped with: push-pull opening, cable hole and hole cover Ø 8.
In the versions with open compartment there is an additional hole cover for Ø 8 cables, in order to allow the passage of the various wiring from the open compartment to the TV compartment; the hole on the shelf has to be made on site.

Sovrapprezzi:
Surcharge:

Per ripiano interno Sp 3,5 (per armadi porta TV)
For inner shelf Th 3.5 (for TV wardrobes)

Elementi JOLLY

JOLLY elements

- Sono compresi i ripiani interni indicati con il tratteggio.

- Inner shelves included, indicated by the dotted line.

P
Dpt 45,8

H
Ht 225,6

* Specificare cerniera Sx o Dx (disegno Sx)
Specify hinge L or R (L drawing)

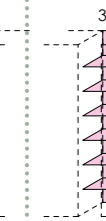
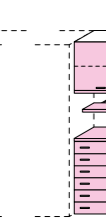
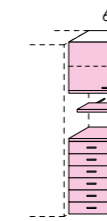
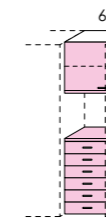
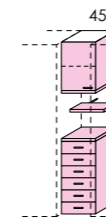
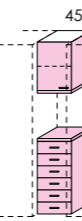

P
Dpt 54,5

COD. VF00.80F * VF00.74W * VF00.82U * VF00.76K * VF00.84G VF00.78X VF00.86Q

VOLO



Configurazioni di elementi predefiniti da posizionare fra due Armadi.

Configurations of predefined elements to be placed between two Wardrobes.

In fase d'ordine, completare con il fianco finale l'armadio che precede gli elementi JOLLY.
When ordering, complete the wardrobe that precedes the JOLLY elements with the final side.

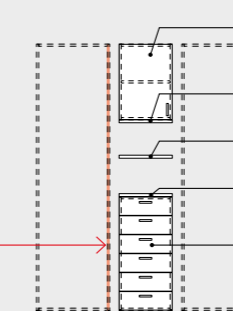

Componibile sospeso H 64
Suspended modular unit Ht 64

Top

Top

Mensole P 26 con reggimensola a scomparsa
Shelf Dpt 26 with integrated shelf holder

Top

Top

Componibile a terra H 96
Floor modular unit Ht 96

Floor modular unit Ht 96

Pannello retro Sp 1,8

Back panel Th 1.8

Ripiani P 52,7 Sp 1,8

Shelves Dpt 52.7 Th 1.8

P
Dpt 45,8

H
Ht 257,6

* Specificare cerniera Sx o Dx (disegno Sx)
Specify hinge L or R (L drawing)

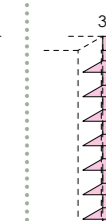
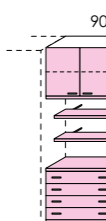
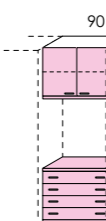
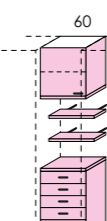
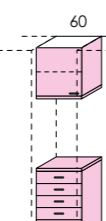
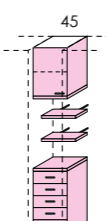
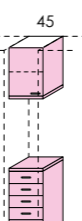

P
Dpt 54,5

COD. VF00.81N * VF00.75C * VF00.83A * VF00.77R * VF00.85P VF00.79D VF00.87W

VOLO



Configurazioni di elementi predefiniti da posizionare fra due Armadi.

Configurations of predefined elements to be placed between two Wardrobes.

In fase d'ordine, completare con il fianco finale l'armadio che precede gli elementi JOLLY.
When ordering, complete the wardrobe that precedes the JOLLY elements with the final side.



Componibile sospeso H 64
Suspended modular unit Ht 64

Top

Top

Mensole P 26 con reggimensola a scomparsa
Shelves Dpt 26 with integrated shelf holder

Top

Top

Componibile a terra H 96
Floor modular unit Ht 96

Floor modular unit Ht 96

Pannello retro Sp 1,8

Back panel Th 1.8

Ripiani Sp 1,8

Shelves Th 1.8

Sovrapprezzi per rallentatore chiusura:
Surcharge for closing retainer:

ANTA
DOOR
CASSETTO
DRAWER

pag. 42
pag. 76
pag. 85
pag. 96

Posizionamento pomelli e maniglie
Knobs and handles position
Accessori per armadi con ante battenti
Wardrobes with hinged doors accessories
Elementi terminali
End elements
Fasce di tamponamento
Filler strips

Accessori per armadi con ante battenti

Wardrobes with hinged doors accessories

	Ripiani interni Sp 2,5 Inner shelves Th 2,5		Ripiani interni Sp 3,5 Inner shelves Th 3,5		Tubi appendiabiti Clothes hanging rails		Cassettiere interne Inner chests of drawers		Divisorio interno Internal partition		Porta scarpe (piano inclinato) Shoe rack (inclined plane)	
	P Dpt 51,5	P Dpt 53	P Dpt 51,5	P Dpt 53	L W 28,1	L W 28,1	H Ht 36,3	H Ht 68,3	H Ht 22,5	H Ht 6,1	H Ht 6,1	H Ht 6,1
	L W -	L W 28,1	L W -	L W 28,1	L W 43,1	L W 43,1	P Dpt 45,8	P Dpt 45,8	P Dpt 45,8	P Dpt 54,5	P Dpt 54,5	P Dpt 54,5
	L W 43,1	L W 43,1	L W 43,1	L W 43,1	L W 58,1	L W 58,1	L W 43,1	L W 43,1	L W 43,1	L W 88,1	L W 88,1	L W 88,1
	L W 58,1	L W 58,1	L W 58,1	L W 58,1	L W 88,1	L W 88,1	L W 58,1	L W 58,1	L W 58,1	L W 88,1	L W 88,1	L W 88,1
	L W 88,1	L W 88,1	L W 88,1	L W 88,1	L W 88,1	L W 88,1	L W 88,1	L W 88,1	L W 88,1	L W 88,1	L W 88,1	L W 88,1
L	COD.		COD.		COD.		COD.		COD.		COD.	
W	-		VF31.02K		-		VF31.06L		-		-	
30	-		VF32.83P		-		VF32.09K		-		-	
45	VF32.80U		VF32.84V		VF31.03R		VF32.86H		-		-	
60	VF32.81A		VF32.85B		VF31.04X		VF32.87Q		-		-	
90	VF32.82G				VF31.05D		VF32.88W		VF32.93U		VF32.94A	
									VF32.95G		VF32.96P	

Accessori per L 90 Accessories for W 90		Saliscendi per abiti Slide rail for clothes	Porta pantaloni estraibile Pull-out trousers rack	Porta cravatte/cinture/ pantaloni estraibile ties/belts holders and pull-out trousers rack	Porta scarpe estraibile Pull-out shoe rack	Cestello estraibile in metallo Metal pull-out basket	2 porta biancheria estraibili in tessuto 2 pull-out fabric laundry baskets	Ganci porta cravatte Tie rack hooks	Svuota tasche Coin tray	Inseribili dove è presente l'icona Can be inserted where the icon is shown
		H Ht 84	H Ht 8 P Dpt 46,5 L W 85,5 ÷ 100	H Ht 8 P Dpt 46,5 L W 85,5 ÷ 100	H Ht 17,2 P Dpt 46,5 L W 85,5 ÷ 100	H Ht 12,4 P Dpt 46,5 L W 85,5 ÷ 100	H Ht 41,5 P Dpt 46,5 L W 85,5 ÷ 100	L W 42	L W 42	Esempio di porta pantaloni con ganci porta cravatte e svuota tasche. Example of pant rack with tie rack hooks and coin tray.
COD.		VF32.89C	VF32.90Z	VF32.91F	VF32.92N	VF33.01M	VF33.02T	VF33.03Z	VF33.04F	

Accessori comuni Shared accessories		Bastone prendi abito Reacher pole	Appendi abiti scorrevole Sliding clothes rail	Porta cravatte Tie hanging rack	Appendi scarpe Hanging shoes rack	Specchio interno Inner mirror
		H Ht 115	Consigliati per armadi ridotti in profondità: P 40 = per profondità superiori a 40 cm. P 24,5 = per profondità inferiori a 40 cm. Recommended for wardrobes with small depth: Dpt 40 = for depth greater than 40 cm. Dpt 24,5 = for depth less than 40 cm.	L W 35,2	L W 45 ÷ 70	H Ht 120 L W 28
		In metallo Metal		Applicabile sull'interno dell'anta Apply on inside of door	Applicabile sul fianco dell'armadio Apply to the side of the wardrobe	
COD.		VF32.97V	VF32.30S	VF32.98B	VF32.99H	VF33.00E

Accessori comuni Shared accessories		Illuminazione con sensore Lighting with sensor	Lampada LED LED lamp	Lampada led SPARK SPARK led lighting	Lampada led SMARTY SMARTY led lamp
		L W 11,2 P Dpt 19,2 Sp Th 0,6	L W 15 P Dpt 6,5 H Ht 1,4	Ø 9,1 H Ht 4,4	L W 40,5 P Dpt 4 H Ht 1
		Kit completi di 1 alimentatore. Cover colore Alluminio e Titanio. Complete kits with 1 Power pack. Cover color Aluminum and Titanium.	Dotata di batteria al litio integrata ricaricabile tramite cavo micro USB (non incluso). Applicabile con le viti fornite o con calamite adesive. Con sensore di presenza. Equipped with integrated lithium battery rechargeable via micro USB cable (not included). Applicable with the provided screws or with adhesive magnets. With presence sensor.	Interruttore manuale o sensore di luce azionabile con interruttore laterale. Applicabile con le viti fornite o con velcro biadesivo. 3 batterie da 1,5v AAA non incluse. Manual switch or light sensor that can be operated with the side switch. Applied with the provided screws or with biadhesive Velcro. 3 - 1.5v AAA batteries not included.	Dotata di batteria integrata ricaricabile tramite cavo USB (incluso). Si aggancia a due placche magnetiche applicabili con viti o biadesivo forniti. Con sensore di presenza. Equipped with integrated battery rechargeable via USB cable (included). Attaches to two magnetic plates that can be applied with the screws or double-sided tape provided. With presence sensor.
COD.		VF32.63C	VF32.65R	VF32.59M	VF34.99S

* Utilizzare solo come piano divisorio fra ante e fra ante e cassetti / cassettoni
Only for use as dividing surface between doors and between doors and drawers / big drawers



Sovrapprezzi per rallentatore chiusura:
Surcharge for closing retainer:

CASSETTO
DRAWER

pag. 42

Posizionamento pomelli e maniglie
Knobs and handles position

Cabine ad angolo ELLE

ELLE corner walk-in wardrobes

- Sono dotate di 2 ante L 45 fornite alla base di spazzolino ferma polvere.
- L'anta Sx è dotata di ferma polvere verticale.
- Sono prive di fondo.
- Sono dotate di piedini regolabili.

- They are equipped with 2 doors W 45 provided at the base with a dust-stop brush.
- L door is fitted with a vertical dust guard.
- They are bottomless.
- They are equipped with adjustable feet.

H
Ht 225,6

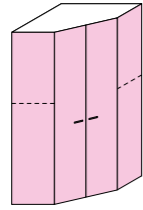

COD.	VF02.15D
VOLO	<input type="radio"/> A
	<input type="radio"/> B
WINDOW	<input type="radio"/> A
	<input type="radio"/> B

H
Ht 257,6

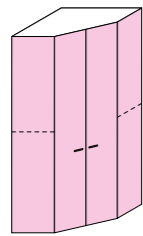

COD.	VF02.16L
VOLO	<input type="radio"/> A
	<input type="radio"/> B
WINDOW	<input type="radio"/> A
	<input type="radio"/> B

Misure d'ingombro

Overall dimensions

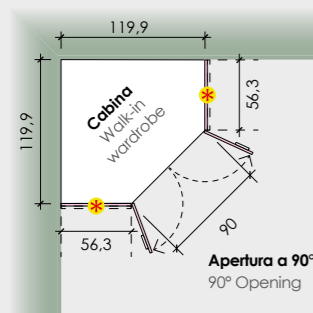

Attrezzatura interna

Internal equipment

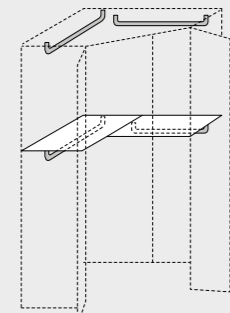

Esempi di utilizzo

Use example



⚠️ DOPPIO FIANCO: Gli armadi affiancati alla cabina ad angolo devono essere completi di fianco iniziale/fianale.

DOUBLE SIDE PANEL: Wardrobes flanked by corner walk-in wardrobe must be complete with initial/end unit side panel.

È dotata di un Ripiano interno con appendiabiti, di un Tubo appendiabiti LUNGO e di uno CORTO.

Walk-in wardrobe is fitted with a inner shelf with Clothes hanging rail, with a LONG clothes hanging rail and with a SHORT one.

Gli armadi L 30/45/60 affiancati alla cabina ad angolo, devono avere le cerniere rivolte verso la cabina. Non è possibile posizionare un letto, un divano o altri elementi con profondità superiore a 56,3 accanto ad una cabina ad angolo.

IMPORTANTI! Consigliamo l'utilizzo della cabina ad angolo affiancata, su entrambi i lati, ad un armadio o un altro elemento che contribuisca alla sua stabilità.

W 30/45/60 wardrobes flanked by corner walk-in wardrobe must have their hinges in the direction of the walk-in wardrobe. It is not possible to place a bed, a sofa or other items more than Dpt 56.3 beside a corner walk-in wardrobe.

IMPORTANTI! We recommend that the corner walk-in wardrobe is, on both sides, supported by a wardrobe or another element that will contribute to its stability.



Sovrapprezzi:
Surcharge:

Per ripiano interno Sp 3,5
For inner shelf Th 3.5

Accessori
Accessories

Sovrapprezzi per rallentatore chiusura:
Surcharge for closing retainer:

ANTA
DOOR

Ripiani interni mobili Sp 2,5

Movable inner shelves Th 2.5

LUNGO
LONG

P Dpt 41,7

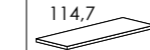

ANGOLO
CORNER

P Dpt 41,7

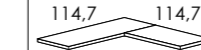

LUNGO con appendiabiti
LONG with clothes hanging rail

P Dpt 41,7



ANGOLO con appendiabiti
CORNER with clothes hanging rail

P Dpt 41,7

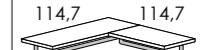

COD.	VF33.05N	VF33.06U	VF33.07A	VF33.08G
-------------	-----------------	-----------------	-----------------	-----------------

Ripiani interni mobili Sp 3,5

Movable inner shelves Th 3.5

LUNGO
LONG

P Dpt 41,7

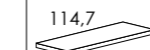

ANGOLO
CORNER

P Dpt 41,7



LUNGO con appendiabiti
LONG with clothes hanging rail

P Dpt 41,7

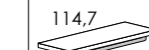

ANGOLO con appendiabiti
CORNER with clothes hanging rail

P Dpt 41,7



COD.	VF31.10B	VF31.11H	VF31.12Q	VF31.13W
-------------	-----------------	-----------------	-----------------	-----------------

Tubi appendiabiti

Clothes hanging rails

In fase d'ordine specificare se per ripiani Sp 2,5 o 3,5
When ordering, specify whether for Th 2.5 or 3.5 shelves

LUNGO
LONG

L W 108,7



CORTO
SHORT

L W 70



COD.	VF33.09P	VF33.10L	VF32.97V	VF33.00E
-------------	-----------------	-----------------	-----------------	-----------------

Bastone prendi abito

Reacher pole

H Ht 115

In metallo
Metal

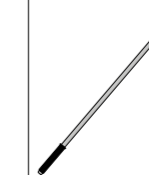

Specchio interno

Inner mirror

L W 28

H Ht 120



Appendi scarpe

Hanging shoes rack

L W 45 ÷ 70

Applicabile sul fianco dell'armadio
Apply to the side of the wardrobe



COD.	VF32.99H	VF32.58E	VF32.63C	VF34.99S
-------------	-----------------	-----------------	-----------------	-----------------

Lampada LED

LED lamp

L W 15

P Dpt 6,5

H Ht 1,4

Dotata di batteria al litio integrata ricaricabile tramite cavo micro USB (non incluso). Applicabile con le viti fornite o con calamite adesive. Con sensore di presenza.

Equipped with integrated lithium battery rechargeable via micro USB cable (not included). Applied with the supplied screws or with adhesive magnets. With presence sensor.

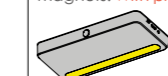

Illuminazione con sensore

Lighting with sensor

L W 11,2

P Dpt 19,2

Sp Th 0,6

Kit completo di 1 alimentatore. Cover colore Alluminio e Titanio. Complete kits with 1 Power pack. Cover color Aluminum and Titanium.

Dotata di batteria integrata ricaricabile tramite cavo USB (incluso). Si aggancia a due placche magnetiche applicabili con viti o biadesivo fornito. Con sensore di presenza.

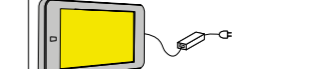

Lampada led SMARTY

SMARTY led lamp

L W 40,5

P Dpt 4

H Ht 1

Dotata di batteria integrata ricaricabile tramite cavo USB (incluso). Si aggancia a due placche magnetiche applicabili con viti o biadesivo fornito. Con sensore di presenza.

Equipped with integrated battery rechargeable via USB cable (included). Attaches to two magnetic plates that can be applied with the screws or double-sided tape provided. With presence sensor.



pag. 42
pag. 85

Posizionamento pomelli e maniglie
Knobs and handles position
Elementi terminali
End elements

Cabine ad angolo ESSE

ESSE corner walk-in wardrobes

- Sono dotate di un'anta L 60 fornita alla base di spazzolino ferma polvere.
- Sono prive di fondo.
- Sono dotate di piedini regolabili.

- They are equipped with W 60 door provided at the base with a dust-stop brush.
- They are bottomless.
- They are equipped with adjustable feet.

H
Ht 225,6

Specificare Sx o Dx
(disegno Dx)
Specify L or R
(drawings R)

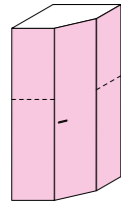

COD. VF02.10W

VOLO	A
	B
WINDOW	A
	B

H
Ht 257,6

Specificare Sx o Dx
(disegno Dx)
Specify L or R
(drawings R)

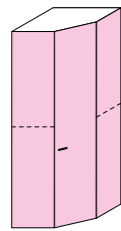

COD. VF02.11C

VOLO	A
	B
WINDOW	A
	B

Misure d'ingombro

Overall dimensions

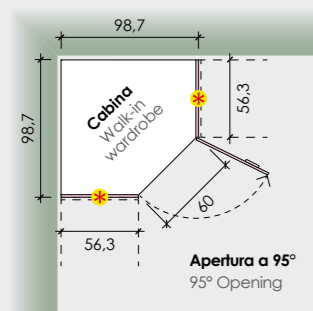

Attrezzatura interna

Internal equipment

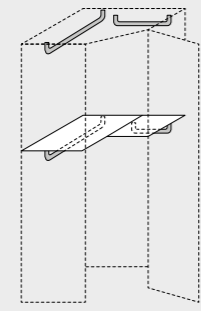

Esempi di utilizzo

Use example

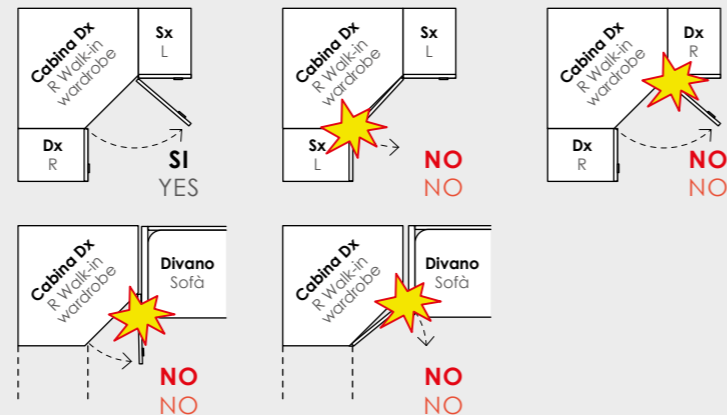

DOPPIO FIANCO: Gli armadi affiancati alla cabina ad angolo devono essere completi di fianco iniziale/fianco finale.
DOUBLE SIDE PANEL: Wardrobes flanked by corner walk-in wardrobe must be complete with initial/end unit side panel.

È dotata di un Ripiano interno con appendiabiti, di un Tubo appendiabiti LUNGO e di uno CORTO.
Walk-in wardrobe is fitted with a inner shelf with Clothes hanging rail, with a LONG clothes hanging rail and with a SHORT one.

Gli armadi L 30/45/60 affiancati alla cabina ad angolo, devono avere le cerniere rivolte verso la cabina. Non è possibile posizionare un letto, un divano o altri elementi con profondità superiore a 56,3 accanto ad una cabina ad angolo.
W 30/45/60 wardrobes flanked by corner walk-in wardrobe must have their hinges in the direction of the walk-in wardrobe. It is not possible to place a bed, a sofa or other items more than Dpt 56.3 beside a corner walk-in wardrobe.

Accessori

Accessories

Ripiani interni mobili Sp 2,5

Movable inner shelves Th 2,5

LUNGO
LONG

P Dpt 41,7

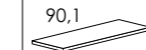

ANGOLO
CORNER

P Dpt 41,7

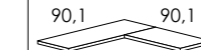

LUNGO con appendiabiti
LONG with clothes hanging rail

P Dpt 41,7



ANGOLO con appendiabiti
CORNER with clothes hanging rail

P Dpt 41,7

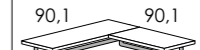

COD. VF34.28X

COD. VF34.29D

COD. VF34.30A

COD. VF34.31G

Ripiani interni mobili Sp 3,5

Movable inner shelves Th 3,5

LUNGO
LONG

P Dpt 41,7

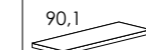

ANGOLO
CORNER

P Dpt 41,7



LUNGO con appendiabiti
LONG with clothes hanging rail

P Dpt 41,7

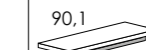

ANGOLO con appendiabiti
CORNER with clothes hanging rail

P Dpt 41,7

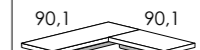

COD. VF31.14C

COD. VF31.15K

COD. VF31.16R

COD. VF31.17X

Tubi appendiabiti

Clothes hanging rails

In fase d'ordine specificare se per ripiani Sp 2,5 o 3,5
When ordering, specify whether for Th 2,5 or 3,5 shelves

LUNGO
LONG

L W 77,5



CORTO
SHORT

L W 47,8



COD. VF34.32P

COD. VF34.33V

Bastone prendi abito

Reacher pole

H Ht 115

In metallo
Metal



COD. VF32.97V

Specchio interno

Inner mirror

L W 28
H Ht 120



COD. VF33.00E

Appendi scarpe

Hanging shoes rack

L W 45 ÷ 70

Applicabile sul fianco dell'armadio
Apply to the side of the wardrobe

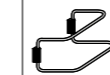

COD. VF32.99H

Lampada LED

LED lamp

L W 15
P Dpt 6,5
H Ht 1,4

Dotata di batteria al litio integrata ricaricabile tramite cavo micro USB (non incluso). Applicabile con le viti fornite o con calamite adesive. Con sensore di presenza.
Equipped with integrated lithium battery rechargeable via micro USB cable (not included). Applicable with the supplied screws or with adhesive magnets. With presence sensor.

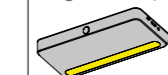

COD. VF32.58E

Illuminazione con sensore

Lighting with sensor

L W 11,2
P Dpt 19,2
Sp Th 0,6

Kit completo di 1 alimentatore. Cover colore Alluminio e Titanio.
Complete kits with 1 Power pack. Cover color Aluminum and Titanium.

Dotata di batteria integrata ricaricabile tramite cavo USB (incluso). Si aggancia a due placche magnetiche applicabili con viti o biadesivo fornito. Con sensore di presenza.
Equipped with integrated battery rechargeable via USB cable (included). Attaches to two magnetic plates that can be applied with the screws or double-sided tape provided. With presence sensor.

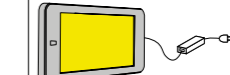

COD. VF32.63C

Lampada led SMARTY

SMARTY led lamp

L W 40,5
P Dpt 4
H Ht 1

Dotata di batteria integrata ricaricabile tramite cavo USB (incluso). Si aggancia a due placche magnetiche applicabili con viti o biadesivo fornito. Con sensore di presenza.
Equipped with integrated battery rechargeable via USB cable (included). Attaches to two magnetic plates that can be applied with the screws or double-sided tape provided. With presence sensor.

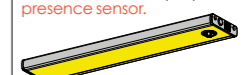

COD. VF34.99S

Sovrapprezzi:
Surcharge:

Per ripiano interno Sp 3,5
For inner shelf Th 3,5

Sovrapprezzi per rallentatore chiusura:
Surcharge for closing retainer:

ANTA
DOOR

pag. 42
pag. 85

Posizionamento pomelli e maniglie
Knobs and handles position
Elementi terminali
End elements

Cabine ad angolo EFFE

EFFE corner walk-in wardrobes

- Sono dotate di un'anta L 60 fornita alla base di spazzolino ferma polvere.
- Sono prive di fondo.
- Sono dotate di piedini regolabili.

- They are equipped with W 60 door provided at the base with a dust-stop brush.
- They are bottomless.
- They are equipped with adjustable feet.

	Sx L	Dx R
H Ht 225,6		
Indicare cerniera Dx o Sx Specify hinge R or L		
COD.	VF02.81R	VF02.85S
VOLO	<input type="radio"/> A <input type="radio"/> B	
WINDOW	<input type="radio"/> A <input type="radio"/> B	

	Sx L	Dx R
H Ht 257,6		
Indicare cerniera Dx o Sx Specify hinge R or L		
COD.	VF02.91W	VF02.95X
VOLO	<input type="radio"/> A <input type="radio"/> B	
WINDOW	<input type="radio"/> A <input type="radio"/> B	

Misure d'ingombro

Overall dimensions

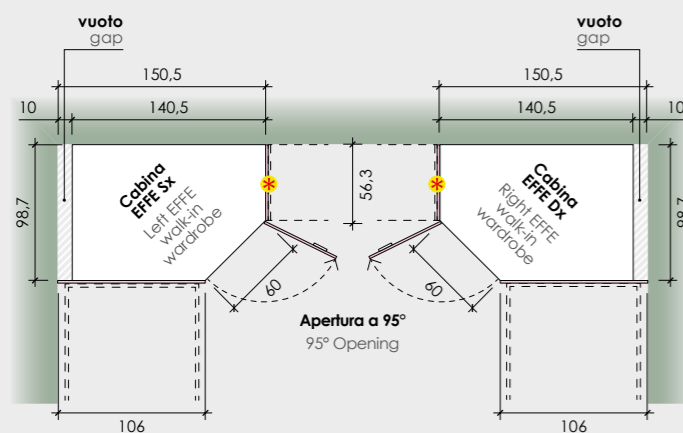

DOPPIO FIANCO: Gli armadi affiancati alla cabina ad angolo devono essere completi di fianco iniziale/fianale.

DOUBLE SIDE PANEL: Wardrobes flanked by corner walk-in wardrobe must be complete with initial/end unit side panel.

Attrezzatura interna

Internal equipment

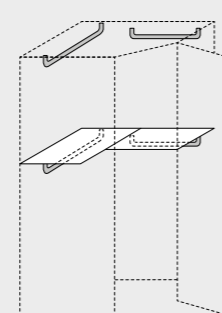

È dotata di un Ripiano interno con appendiabiti e di 2 Tubi appendiabiti.

Walk-in wardrobe is fitted with a inner shelf with Clothes hanging rail and 2 Clothes hanging rails.

Esempi di utilizzo

Use example



Gli armadi L 30/45/60 affiancati alla cabina ad angolo, devono avere le cerniere rivolte verso la cabina.

W 30/45/60 wardrobes flanked by corner walk-in wardrobe must have their hinges in the direction of the walk-in wardrobe.

Accessori

Accessories

	Ripiani interni mobili Sp 2,5 Movable inner shelves Th 2,5	ANGOLO CORNER	Con appendiabiti With clothes hanging rail	ANGOLO con appendiabiti CORNER with clothes hanging rail
P Dpt 41,7		P Dpt 41,7	P Dpt 41,7	P Dpt 41,7
COD.	VF35.46Z VF35.50R	VF35.47F VF35.51X	VF35.48N VF35.52D	VF35.49U VF35.53L

	Ripiani interni mobili Sp 3,5 Movable inner shelves Th 3,5	ANGOLO CORNER	Con appendiabiti With clothes hanging rail	ANGOLO con appendiabiti CORNER with clothes hanging rail
P Dpt 41,7		P Dpt 41,7	P Dpt 41,7	P Dpt 41,7
COD.	VF35.54S VF35.58T	VF35.55Y VF35.59Z	VF35.56E VF35.60W	VF35.57M VF35.61C

	Tubi appendiabiti Clothes hanging rails	Bastone prendi abito Reacher pole	Specchio interno Inner mirror
L W 77,5		H Ht 115	L W 28 H Ht 120
COD.	VF34.32P	VF32.97V	VF33.00E

	Appendi scarpe Hanging shoes rack	Lampada LED LED lamp	Illuminazione con sensore Lighting with sensor	Lampada led SMARTY SMARTY led lamp
L W 45 ÷ 70		L W 15 P Dpt 6,5 H Ht 1,4	L W 11,2 P Dpt 19,2 Sp Th 0,6	L W 40,5 P Dpt 4 H Ht 1
COD.	VF32.99H	VF32.58E	VF32.63C	VF34.99S

Sovrapprezzi:
Surcharge:
Per ripiano interno Sp 3,5
For inner shelf Th 3.5

Sovrapprezzi per rallentatore chiusura:
Surcharge for closing retainer:
ANTA
DOOR

pag. 42
pag. 85

Posizionamento pomelli e maniglie
Knobs and handles position
Elementi terminali
End elements

Angoli interi per armadi - P 56,3

Corner wardrobes - Dpt 56.3

- Non è possibile invertire gli ingombri. La maniglia è sempre posizionata sull'anta Dx.
- Rallentatori chiusura anta non previsti.
- Sono compresi i ripiani interni indicati con il tratteggio e 2 tubi appendiabiti.
- Sono dotati di piedini regolabili.

- Dimensions cannot be reversed. The handle is always fitted on the R door.
- Door closing retainers not provided.
- Inner shelves indicated by the dotted line and 2 clothes hanging rails included.
- They are equipped with adjustable feet.

H
Ht 225,6

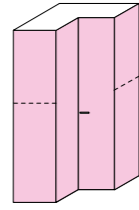

COD. VF02.00R

VOLO A

WINDOW B

H
Ht 257,6

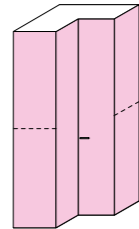

COD. VF02.01X

VOLO A

WINDOW B

Misure d'ingombro
Overall dimensions

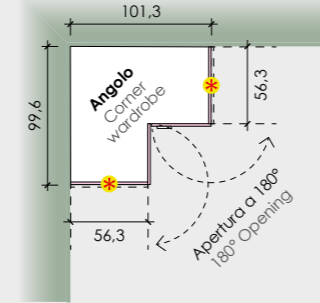

DOPPIO FIANCO: Gli armadi affiancati all'angolo ad angolo devono essere completi di fianco iniziale/finale.
DOUBLE SIDE PANEL: Wardrobes flanked by corner wardrobe must be complete with initial/end unit side panel.

Esempi di utilizzo
Use example

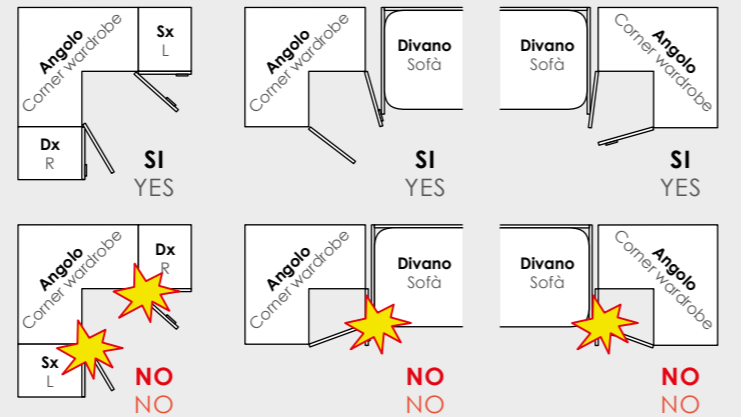

Per la totale apertura delle ante si consiglia di affiancare all'angolo elementi L 30/45/60 con cerniere rivolte verso l'angolo e/o elementi L 90 sprovvisti di cassetti.
Per il posizionamento di elementi di profondità superiore a 56,3 (es. letto, divano, etc.) accanto ad un angolo intero, rispettare le distanze minime indicate.

So as to be able to open the doors fully we recommend placing W 30/45/60 elements in the corner with the hinges facing the corner itself and/or W 90 elements without drawers.
For the positioning of elements that are of greater depth than 56,3 (bed, sofa, etc.) alongside corner wardrobe must respect the minimum distances indicated above.

Ripiano interno Sp 2,5
Inner shelf Th 2.5

P Dpt 51,5

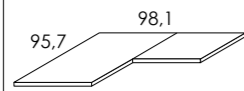

COD. VF34.34B

Ripiano interno Sp 3,5
Inner shelf Th 3.5

P Dpt 51,5

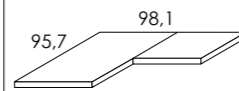

COD. VF31.18D

Tubo appendiabiti
Clothes hanging rail

L W 60

In fase d'ordine specificare se per ripiani Sp 2,5 o 3,5
When ordering, specify whether for Th 2.5 or 3.5 shelves



COD. VF34.35H

Bastone prendi abito
Reacher pole

H Ht 115

In metallo
Metal



COD. VF32.97V

Specchio interno
Inner mirror

L W 28
H Ht 120



COD. VF33.00E

Appendi scarpe
Hanging shoes rack

L W 45 ÷ 70

Applicabile sul fianco dell'armadio
Apply to the side of the wardrobe



COD. VF32.99H

Terminali - P 56,3

End units - Dpt 56.3

- Vanno sempre affiancati ad un armadio.
- Montano ante con cerniere 30° e basette dedicate.
- Sono compresi i ripiani interni indicati con il tratteggio.
- Non è possibile montare il tubo appendiabiti.
- Sono dotati di piedini regolabili.

- They always go side by side to a wardrobe.
- Fitted with doors with 30° opening hinges with mounting plates.
- Inner shelves included, indicated by the dotted line.
- Clothes hanging rail cannot be installed inside end units.
- They are equipped with adjustable feet.

Sx L

L W 38,8

Dx R

L W 40,6

H
Ht 225,6

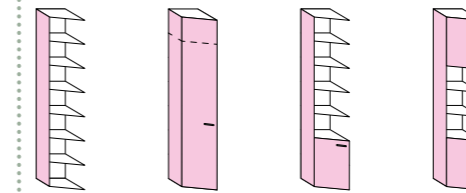

COD. VF02.20B VF02.21H VF02.22Q VF02.23W

VOLO A

WINDOW B

H
Ht 257,6

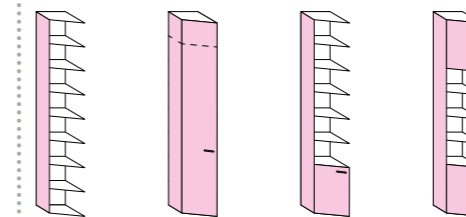

COD. VF02.28D VF02.29L VF02.30G VF02.31P

VOLO A

WINDOW B

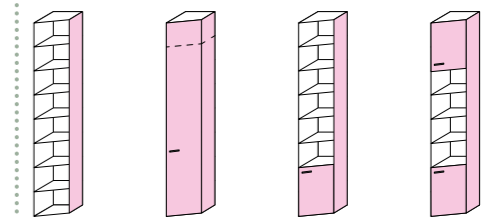

COD. VF02.32V VF02.33B VF02.34H VF02.35Q

Misure d'ingombro
Overall dimensions

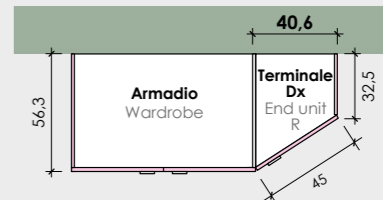
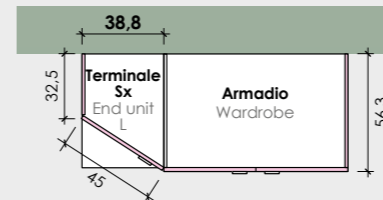

Accessori
Accessories

Ripiani per Terminali Sp 2,5
Shelves for End units Th 2.5

L W 37
P Dpt 53

Sx L



COD. VF34.36Q

Dx R



COD. VF34.37W

Ripiani per Terminali Sp 3,5
Shelves for End units Th 3.5

L W 37
P Dpt 53

Sx L



COD. VF31.19L

Dx R



COD. VF31.20G

Sovrapprezzi per rallentatore chiusura:
Surcharge for closing retainer:

ANTA (per Terminali)
DOOR (for End units)

pag. 42

Posizionamento pomelli e maniglie
Knobs and handles position

Librerie terminali ORDER - L 32,5 P 54,5 - con contenitore L 30 P 32,5

ORDER end bookshelves - W 32.5 Dpt 54.5 - with cabinet W 30 Dpt 32.5

- Sono compresi ripiani interni ogni 32 cm.
- Sono dotate di piedini regolabili.
- Per garantire la stabilità sono necessarie 4 mensole sagomate equidistanti.

- Includes inner shelves every 32 cm.
- They are equipped with adjustable feet.
- To ensure the stability 4 equally-spaced shaped shelves must be inserted.

	Sx L				Dx R			
H Ht 225,6								
COD.	VF02.50T	VF02.51Z	VF02.52F	VF02.53N	VF02.54U	VF02.55A	VF02.56G	VF02.57P
VOLO	(A)	(B)						
H Ht 257,6								
COD.	VF02.58V	VF02.59B	VF02.60Y	VF02.61E	VF02.62M	VF02.63T	VF02.64Z	VF02.65F
VOLO	(A)	(B)						

Librerie terminali OLA - L 30,7 P 53,6

OLA end bookshelves - W 30.7 Dpt 53.6

- Per garantire la stabilità sono necessarie 4 mensole sagomate equidistanti.
- Sono dotate di piedini regolabili.

- To ensure the stability 4 equally-spaced shaped shelves must be inserted.
- They are equipped with adjustable feet.

	Sx L		Dx R	
H Ht 225,6				
COD.	VF02.40N	VF02.41U	VF02.42A	VF02.43G
VOLO	(A)	(B)		
H Ht 257,6				
COD.	VF02.44P	VF02.45V	VF02.46B	VF02.47H
VOLO	(A)	(B)		

Accessori	Mensola ORDER	BOLLINO	PLUS	Specchio	Specchio
ORDER shelf	L W 24,4 P Dpt 30,6 Sp Th 2,5	Ø 10 P Dpt 4	L W 4,3 P Dpt 3 H Ht 6,5	Ø 30	L W 28 H Ht 120 * abbinabile matched
COD.	VF34.38C	VF32.61Q	VF32.62W	VF34.39K	VF33.00E
VOLO	(A)	(B)			

Accessori	Mensola OLA	BOLLINO	PLUS	Specchio	Specchio
OLA shelf	L W 51,8 P Dpt 29 Sp Th 2,5	Ø 10 P Dpt 4	L W 4,3 P Dpt 3 H Ht 6,5	Ø 30	L W 28 H Ht 120 * abbinabile matched
COD.	VF34.40F	VF32.61Q	VF32.62W	VF34.39K	VF33.00E
VOLO	(A)	(B)			

Sovrapprezzi per rallentatore chiusura:
Surcharge for closing retainer:

+ 9,00 ANTA
DOOR

pag. 42

Posizionamento pomelli e maniglie
Knobs and handles position

Librerie terminali SLASH - L 26 P 54,5 - con porta scarpe
 SLASH end bookshelves - W 26 Dpt 54.5 - with shoe rack

- Nella parte inferiore sono presenti 3 ante portascarpe.
- Sono dotate di piedini regolabili.

- In the lower part there are 3 shoe rack doors.
- They are equipped with adjustable feet.

H
Ht 225,6

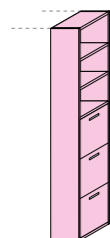

COD. VF02.48Q

VOLO

A
B

H
Ht 257,6

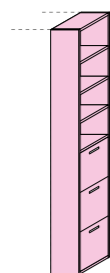

COD. VF02.49W

VOLO

A
B

Ante porta scarpe
 Shoe rack doors

Frontali e separatori interni in pannello, struttura con sistema di ribaltamento in plastica. È possibile montare tutte le maniglie della collezione ad eccezione di BLADE, BAND e TALL.

Panel fronts and internal separators, structure with plastic folding system. It is possible to install all the handles of the collection except for BLADE, BAND and TALL.

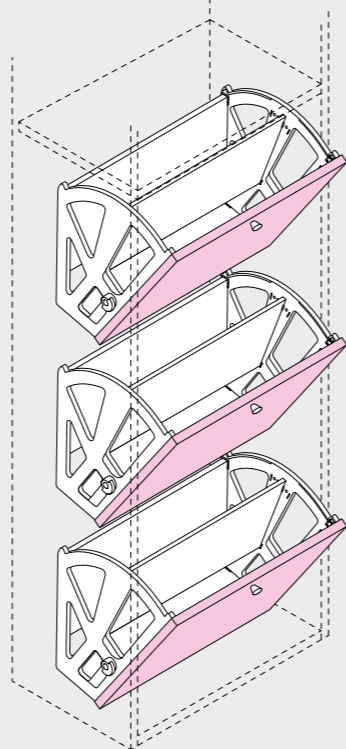

Librerie terminali PILL - L 26 P 50,9
 PILL end bookshelves - W 26 Dpt 50.9

H
Ht 225,6

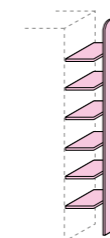

COD. VF02.36W

VOLO

A
B

H
Ht 257,6

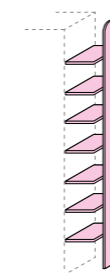

COD. VF02.37C

VOLO

A
B

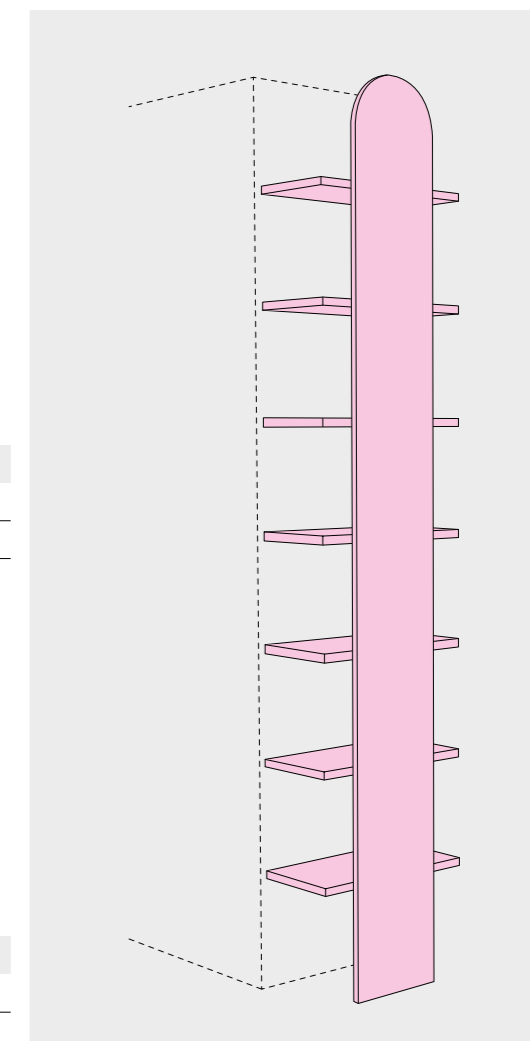

Arredi con ante
battenti e scorrevoli
Furniture with hinged
and sliding doors

Armadi con ante scorrevoli FREE - H 225,3 P 61,5

Wardrobes with FREE sliding doors - Ht 225.3 Dpt 61.5

- Sono compresi i ripiani interni indicati con il tratteggio.
- Sono dotati di 2 tubi appendiabiti per vano.
- Sono dotati di piedini regolabili e parapolvere superiore sull'anta sporgente.
- Lo specchio Sp 0,4 è applicato su un pannello in nobilitato Sp 1,4.

- Inner shelves included, indicated by the dotted line.
- Each compartment is equipped with 2 clothes hanging rails.
- They are equipped with adjustable feet and upper dust-cover on external door.
- Th 0.4 mirror is applied on a Th 1.4 melamine panel.

L 146,7
W

Ante L 75.
Indicare anta sporgente
Dx o Sx.
W 75 doors.
Indicate whether projecting
door is R or L.

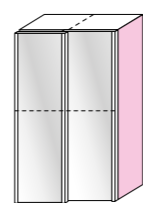
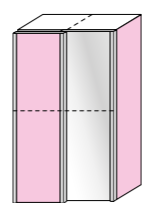
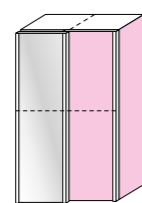
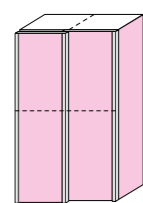

COD. VF03.44T VF03.45Z VF03.46F VF03.47N

A
B

L 178,7
W

Ante L 91.
Indicare anta sporgente
Dx o Sx.
W 91 doors.
Indicate whether projecting
door is R or L.

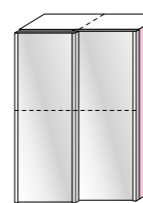
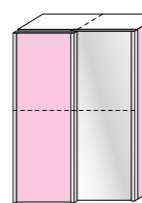
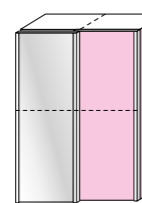
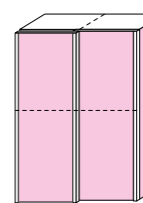

COD. VF03.00V VF03.01B VF03.02H VF03.24G

A
B

L 219,5
W

Ante L 75.
W 75 doors.

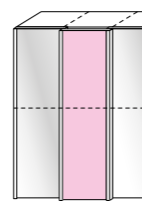
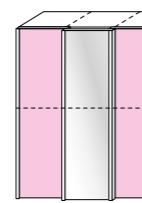
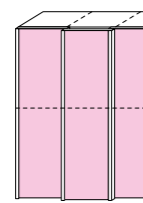

COD. VF03.48U VF03.49A VF03.50X VF03.51D

A
B

L 267,5
W

Ante L 91.
W 91 doors.

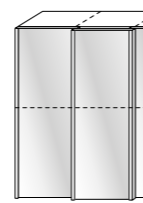
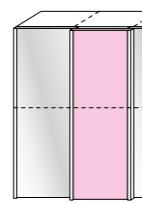
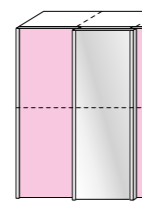
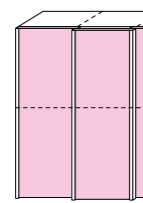

COD. VF03.03Q VF03.04W VF03.25P VF03.26V

A
B



SP7L

Sovrapprezzi:
Surcharge:

Per ripiano interno Sp 3,5
For inner shelf Th 3.5

Sovrapprezzi per rallentatore chiusura:
Surcharge for closing retainer:

2 ANTE SCORREVOLI
2 SLIDING DOORS
3 ANTE SCORREVOLI
3 SLIDING DOORS

Schema apertura ante scorrevoli

Opening diagram for sliding doors

Non è possibile invertire il verso di apertura.
The opening direction cannot be inverted.

L 146,7 - 178,7 (2 ante)
W (2 doors)

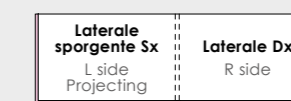

L 219,5 - 267,5 (3 ante)
W (3 doors)

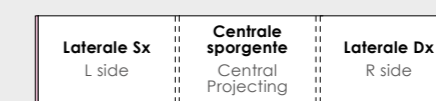

Profilo maniglia:
Handle groove strip:

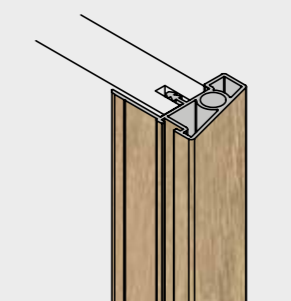

Colori disponibili:
Available colors:



Armadi con ante
battenti e scorrevoli
Wardrobes with hinged
and sliding doors

Armadi con ante scorrevoli FREE - H 257,3 P 61,5

Wardrobes with FREE sliding doors - Ht 257.3 Dpt 61.5

- Sono compresi i ripiani interni indicati con il tratteggio.
- Sono dotati di 2 tubi appendiabiti per vano.
- Sono dotati di piedini regolabili e parapolvere superiore sull'anta sporgente.
- Lo specchio Sp 0,4 è applicato su un pannello in nobilitato Sp 1,4.

- Inner shelves included, indicated by the dotted line.
- Each compartment is equipped with 2 clothes hanging rails.
- They are equipped with adjustable feet and upper dust-cover on external door.
- Th 0.4 mirror is applied on a Th 1.4 melamine panel.

L 146,7
W

Ante L 75.
Indicare anta sporgente
Dx o Sx.
W 75 doors.
Indicate whether projecting
door is R or L.

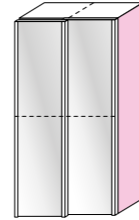
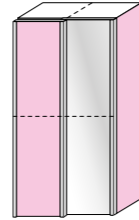
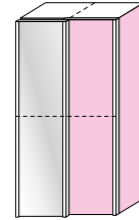
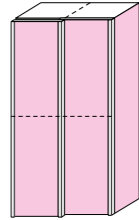

COD. VF03.52L VF03.53S VF03.54Y VF03.55E

A
B

L 178,7
W

Ante L 91.
Indicare anta sporgente
Dx o Sx.
W 91 doors.
Indicate whether projecting
door is R or L.

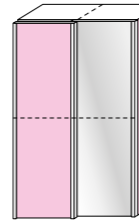
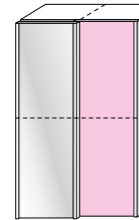
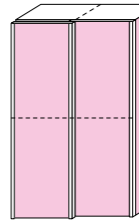

COD. VF03.10A VF03.11G VF03.12P VF03.28H

A
B

L 219,5
W

Ante L 75.
W 75 doors.

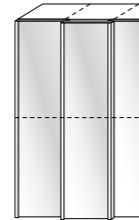
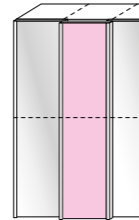
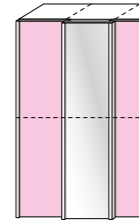
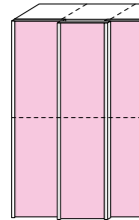

COD. VF03.56M VF03.57T VF03.58Z VF03.59F

A
B

L 267,5
W

Ante L 91.
W 91 doors.

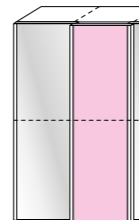
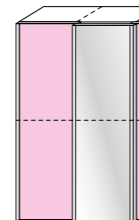
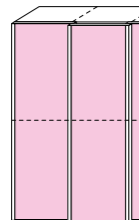

COD. VF03.13V VF03.14B VF03.29Q VF03.30M

A
B



Sovrapprezzi:
Surcharge:

Per ripiano interno Sp 3,5
For inner shelf Th 3.5

Sovrapprezzi per rallentatore chiusura:
Surcharge for closing retainer:

2 ANTE SCORREVOLI
2 SLIDING DOORS
3 ANTE SCORREVOLI
3 SLIDING DOORS

Schema apertura ante scorrevoli

Opening diagram for sliding doors

Non è possibile invertire il verso di apertura.
The opening direction cannot be inverted.

L 146,7 - 178,7 (2 ante)
W (2 doors)

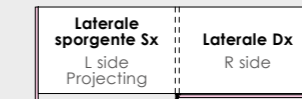

L 219,5 - 267,5 (3 ante)
W (3 doors)

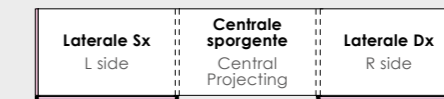

Profilo maniglia:
Handle groove strip:

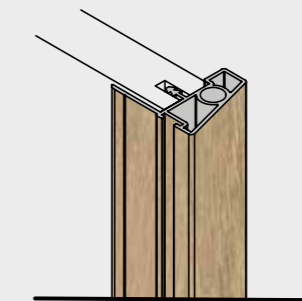

Colori disponibili:
Available colors:



Accessori per armadi con ante scorrevoli



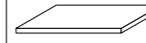
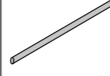

Wardrobes with sliding doors accessories

L
W 70,3

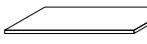
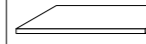
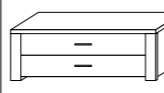
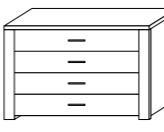
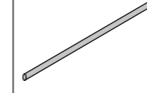
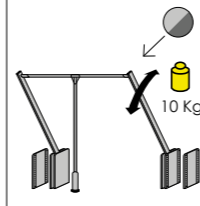
	Ripiano interno Sp 2,5 Inner shelf Th 2.5 P Dpt 51,5 	Ripiano interno Sp 3,5 Inner shelf Th 3.5 P Dpt 51,5 	Tubo appendiabiti Clothes hanging rail 
COD.	VF35.43E	VF35.44M	VF35.45T

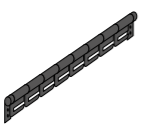
L
W 86,3

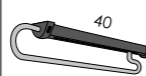
	Ripiano interno Sp 2,5 Inner shelf Th 2.5 P Dpt 51,5 	Ripiano interno Sp 3,5 Inner shelf Th 3.5 P Dpt 51,5 	Cassettiere interne P 46 Inner chests of drawers Dpt 46 H Ht 36,3 	Cassettiere interne P 46 Inner chests of drawers Dpt 46 H Ht 68,3 	Tubo appendiabiti Clothes hanging rail 	Saliscendi per abiti Slide rail for clothes H Ht 84 
COD.	VF34.41N	VF31.21P	VF34.42U	VF34.43A	VF34.44G	VF33.11S

	Porta cravatte Tie hanging rack L W 35,2 Applicabile sul fianco dell'armadio Apply to the side of wardrobe 	Appendi scarpe Hanging shoes rack L W 45 ÷ 70 Applicabile sul fianco dell'armadio Apply to the side of wardrobe 	Appendi abiti scorrevoli Sliding clothes rail Consigliati per armadi ridotti in profondità: P 40 = per profondità superiori a 40 cm. P 24,5 = per profondità inferiori a 40 cm. Recommended for wardrobes with small depth: Dpt 40 = for depth greater than 40 cm. Dpt 24.5 = for depth less than 40 cm.  	
COD.	VF32.98B	VF32.99H	VF32.30S	VF32.31Y

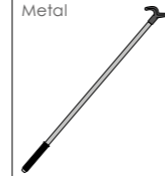
	Bastone prendi abito Reacher pole H Ht 115 In metallo Metal 
COD.	VF32.97V

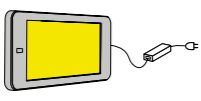
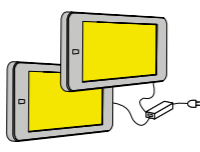
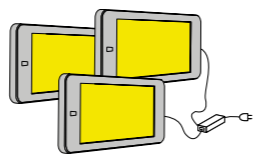
	Illuminazione con sensore Lighting with sensor L W 11,2 P Dpt 19,2 Sp Th 0,6 Kit completi di 1 alimentatore. Cover colore Alluminio e Titanio. Complete kits with 1 Power pack. Cover color Aluminum and Titanium. 		
COD.	VF32.63C	VF32.64K	VF32.65R

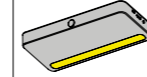
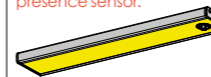
	Lampada led SPARK SPARK led lighting Ø 9,1 H Ht 4,4 Interruttore manuale o sensore di luce azionabile con interruttore laterale. Applicabile con le viti fornite o con velcro biadesivo. 3 batterie da 1,5v AAA non incluse. Manual switch or light sensor that can be operated with the side switch. Applied with the provided screws or with biadhesive Velcro. 3 - 1.5v AAA batteries not included. 	Lampada LED LED lamp L W 15 P Dpt 6,5 H Ht 1,4 Dotata di batteria al litio integrata ricaricabile tramite cavo micro USB (non incluso). Applicabile con le viti fornite o con calamite adesive. Con sensore di presenza. Equipped with integrated lithium battery rechargeable via micro USB cable (not included). Applied with the supplied screws or with adhesive magnets. With presence sensor. 	Lampada led SMARTY SMARTY led lamp L W 40,5 P Dpt 4 H Ht 1 Dotata di batteria integrata ricaricabile tramite cavo USB (incluso). Si aggancia a due placche magnetiche applicabili con viti o biadesivo fornito. Con sensore di presenza. Equipped with integrated battery rechargeable via USB cable (included). Attaches to two magnetic plates that can be applied with the screws or double-sided tape provided. With presence sensor. 
COD.	VF32.59M	VF32.58E	VF34.99S

Sovrapprezzi per rallentatore chiusura:
 Surcharge for closing retainer:

CASSETTO
 DRAWER

pag. 42

Posizionamento pomelli e maniglie
 Knobs and handles position

Fasce di tamponamento

Filler strips

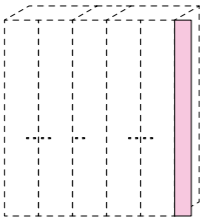
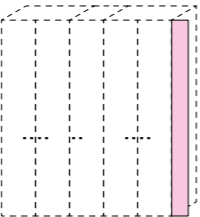
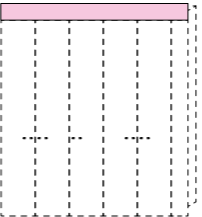
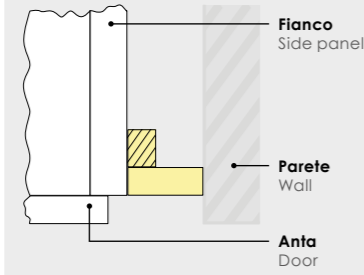
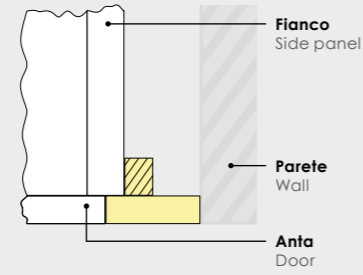
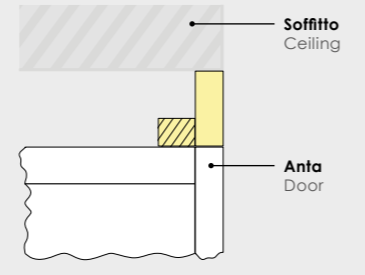
	Fascia di tamponamento verticale (vena verticale) per anta battente e scorrevole Vertical infill (vertical vein) for hinged door and sliding door	Fascia di tamponamento verticale con sormonto (vena verticale) per anta battente Vertical infill with overlap (vertical vein) for hinged door	Fascia di tamponamento orizzontale (vena orizzontale) per anta battente Horizontal infill (Horizontal vein) for hinged door
COD.	VF16.34D	VF16.35L	VF16.36S
A B			
	 <p> Fianco Side panel Parete Wall Anta Door </p> <p> Altezza minima: 320 mm Minimum height: Altezza massima: 3.000 mm Maximum height: Larghezza minima: 40 mm Minimum width: Larghezza massima: 250 mm Maximum width: </p>	 <p> Fianco Side panel Parete Wall Anta Door </p> <p> Altezza minima: 320 mm Minimum height: Altezza massima: 3.000 mm Maximum height: Larghezza minima: 40 mm Minimum width: Larghezza massima: 250 mm Maximum width: </p>	 <p> Soffitto Ceiling Anta Door </p> <p> Altezza minima: 40 mm Minimum height: Altezza massima: 250 mm Maximum height: Larghezza minima: 320 mm Minimum width: Larghezza massima: 3.000 mm Maximum width: </p>

Facciate Fronts
VOLO

Finiture GRUPPO 1
GROUP 1 finishes

Finiture GRUPPO 2
GROUP 2 finishes

Rovere white*

A ☆ Rovere white RW3Q	A ☆ Noce brina NB5T	A Bianco opaco B17A	A Grigio Dorian GL4R	B ☆ Cemento artico CA7A	B ☆ Rovere gesso RG9L
B ☆ Royal oak RS4B	B ☆ Rovere cognac RC3Q	B Grigio titanio GZ8T			
B Papaya PP7H	B Miele ML4B	B Oliva LV5T	B Cadaques CQ3Q		

Vetri Glass

Ante Doors
WINDOW

Colori telaio
Frame colours

Trasparente TR9M	Trasparente fumé FT8P	Stop sol ST6P	Specchio SP7L	Alluminio AL1A	Titan grey TG7H
----------------------------	---------------------------------	-------------------------	-------------------------	--------------------------	---------------------------

Rovere white* Finitura unica per tutti i componenti in pannello presenti a listino non evidenziati con il colore Finiture GRUPPO 1 e/o Finiture GRUPPO 2.
Unique finish for all the panel components shown in the pricelist not highlighted with the color finishes GROUP 1 and/or finishes GROUP 2.

- A** Finiture in fascia di prezzo A
Finishes in price range A
- B** Finiture in fascia di prezzo B
Finishes in price range B
- ☆ Finiture con effetto materico
Finishes with textured effect

ARMADI PONTE, LETTI A SOPPALCO E A CASTELLO
BRIDGE WARDROBES, LOFT AND BUNK BEDS

Armadi a ponte - H 257,6 P 56,3 Bridge wardrobes - Ht 257.6 Dpt 56.3	pag. 100
Letti a soppalco BRIDGE - H 257,6 P 95 - per scaletta in metallo BRIDGE loft beds - Ht 257.6 Dpt 95 - for metal ladder	pag. 102
Letti a soppalco BRIDGE - H 257,6 P 100 - con scaletta laterale BRIDGE loft beds - Ht 257.6 Dpt 100 - with side stair	pag. 104
Accessori per armadi ponte e letti a soppalco Bridge wardrobes and loft beds accessories	pag. 106
Letti a castello WINNER - H 187 L 101,5 - per scaletta in metallo WINNER bunk beds - Ht 187 W 101.5 - for metal ladder	pag. 108
Letti a castello WINNER - H 187 L 101,5 - con scaletta laterale WINNER bunk beds - Ht 187 W 101.5 - with side stair	pag. 109
Letti a castello REVOLUTION - H 198 L 210 REVOLUTION bunk beds - Ht 198 W 210	pag. 110
Letti a castello REVOLUTION - H 198 L 210 - con cabina REVOLUTION bunk beds - Ht 198 W 210 - with walk-in wardrobe	pag. 112
Letti a castello REVOLUTION - H 198 L 210 - con armadio REVOLUTION bunk beds - Ht 198 W 210 - with wardrobe	pag. 114
Accessori per letti a castello REVOLUTION REVOLUTION bunk beds accessories	pag. 116
Letti a castello TITANO - H 179,3 L 200 TITANO bunk beds - Ht 179.3 W 200	pag. 118

Armadio a ponte su misura:
 Custom-made bridge wardrobe:

per ogni singolo taglio, da sommare al costo dell'armadio a ponte di misura superiore.
 for each individual cut, to be added to the cost of the bridge wardrobe with a larger size.

Elementi sopra barra
 Over bar elements
 H Ht **128**

Vano ponte
 Niche of overhead structure
 H Ht **129,6**

L W	118	178	208	223	238		
COD.	VF04.00Z	VF04.01F	VF04.02N	VF04.03U	VF04.06P	VF04.04A	VF04.05G
VOLO	(A)	(B)	(A)	(B)	(A)	(B)	(A)
WINDOW	(A)	(B)	(A)	(B)	(A)	(B)	(A)

Fianchi di sostegno per pensile H 128
 Support side panels for wall unit Ht 128
 P Dpt 54,5
 Sp Th 1,8



Elementi sopra barra
 Over bar elements
 H Ht **96**

Vano ponte
 Niche of overhead structure
 H Ht **161,6**

L W	118	178	208	223	238		
COD.	VF04.10E	VF04.11M	VF04.12T	VF04.13Z	VF04.16U	VF04.14F	VF04.15N
VOLO	(A)	(B)	(A)	(B)	(A)	(B)	(A)
WINDOW	(A)	(B)	(A)	(B)	(A)	(B)	(A)

Fianchi di sostegno per pensile H 96
 Support side panels for wall unit Ht 96
 P Dpt 54,5
 Sp Th 1,8



Mensole sottoponte
 Shelves for use beneath overhead composition
 P Dpt 26,5
 Sp Th 2,5

L W	118	178	208	223	238		
COD.	VF04.20L	VF04.21S	VF04.22Y	VF04.23E	VF04.24M		

Con reggimensola
 With shelf holders

LAMPO KUB

Provvisti di ferramenta per fissaggio a pannello.
 In caso di fissaggio a muro la scelta del tipo di tassello da utilizzare dovrà essere fatta dal montatore sulla base delle caratteristiche della parete.
 Complete with hardware for fixing to panel.
 In case of wall fixing the choice of hardware depends on the wall conditions and should be made by the assembler.

Sovrapprezzi per rallentatore chiusura:
 Surcharge for closing retainer:

ANTA
 DOOR

Informazioni tecniche:
 Technical information:

- È indispensabile completare le composizioni con i fianchi di sostegno o gli armadi P 56,3.
- L'elemento sopra barra è costituito da cappello e fondo interi e da tramezzi interni (vedi tratteggi); ogni vano è dotato di 1 tubo appendiabiti.
- I pannelli retro sono dotati di piedini regolabili.
- It is absolutely necessary to complete compositions with side support panels or wardrobes Dpt 56.3.
- The over bar element consists of an inner top and bottom and internal partitions (see hatches); each compartment is equipped with 1 clothes hanging rail.
- Back panels are equipped with adjustable feet.

- | | | |
|---|----------------|--------------|
| 1 | Tramezzo | Partition |
| 2 | Cappello | Top |
| 3 | Fondo | Bottom panel |
| 4 | Pannello retro | Back panel |
| 5 | Barra ponte | Overhead bar |

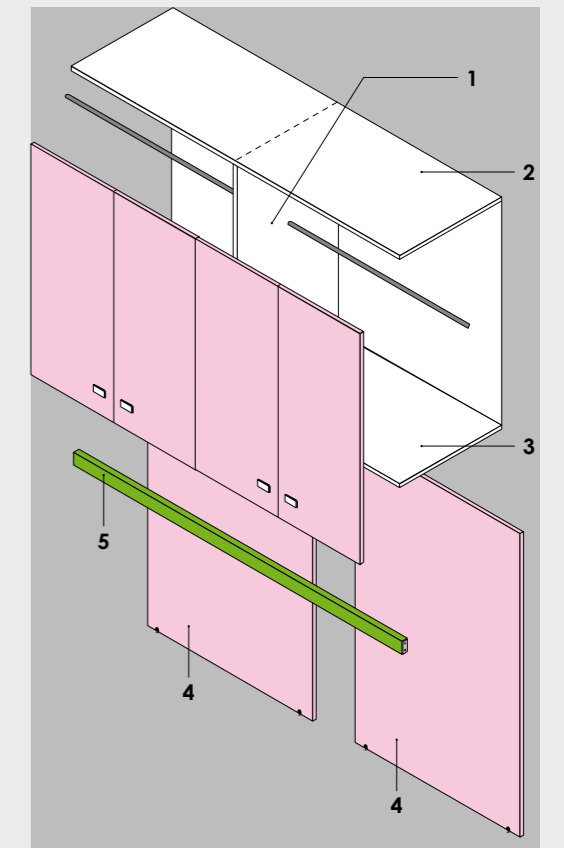

CARICO MASSIMO CONSIGLIATO
 (al netto delle mensole)
 MAXIMUM RECOMMENDED LOAD
 (shelves weight excluded)

30 Kg per ogni coppia di reggimensola
 for every pair of shelf holders

NB. Il carico si intende uniformemente distribuito sulla mensola. Tra 2 reggimensola ci deve essere una distanza non superiore a 135 cm.

NOTE. Load shall be evenly distributed on the shelf. The maximum distance between 2 shelf holders shall be 135 cm.

pag. 42
 pag. 106

Posizionamento pomelli e maniglie
 Knobs and handles position
 Accessori per armadi ponte e letti a soppalco
 Overhead wardrobes and loft beds accessories

Letti a soppalco BRIDGE - H 257,6 P 95 - per scaletta in metallo

BRIDGE loft beds - Ht 257.6 Dpt 95 - for metal ladder

L
W **257,3**

L
W **302,3**

CON 2 BARRE PONTE WITH 2 OVERHEAD BARS

Specificare Sx o Dx (disegno Dx)
Specify L or R (R drawing)

Elemento soprabarra Over bar element

H
Ht **128**

Vano ponte Niche of overhead structure

H
Ht **129,6** L
W **208**

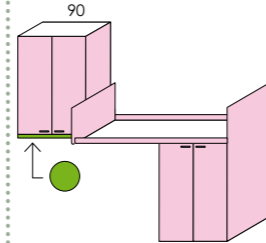
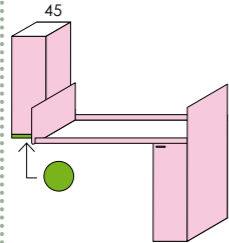

COD. **VF04.50B**

COD. **VF04.51H**

VOLO

A
B

CON PANNELLI RETRO WITH BACK PANELS

Specificare Sx o Dx (disegno Dx)
Specify L or R (R drawing)

Elemento soprabarra Over bar element

H
Ht **128**

Vano ponte Niche of overhead structure

H
Ht **129,6** L
W **208**

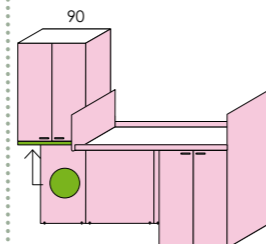
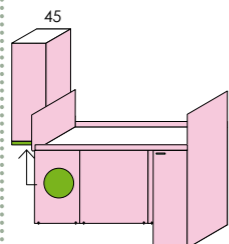

COD. **VF04.60G**

COD. **VF04.61P**

VOLO

A
B

Mensola sottoponte Shelf for use beneath overhead composition

P Dpt 26,5
Sp Th 2,5

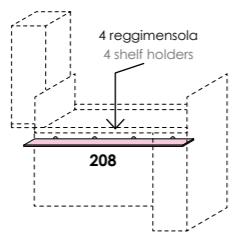

COD. Con reggimensola
With shelf holders **VF04.22Y**

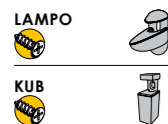

CARICO MASSIMO CONSIGLIATO (al netto delle mensole)

MAXIMUM RECOMMENDED LOAD
(shelves weight excluded)

30 Kg per ogni coppia di reggimensola
for every pair of shelf holders

NB. Il carico si intende uniformemente distribuito sulla mensola. Tra 2 reggimensola ci deve essere una distanza non superiore a 135 cm.

NOTE. Load shall be evenly distributed on the shelf. The maximum distance between 2 shelf holders shall be 135 cm.

Provvisti di ferramenta per fissaggio a pannello.
In caso di fissaggio a muro la scelta del tipo di tassello da utilizzare dovrà essere fatta dal montatore sulla base delle caratteristiche della parete.
Complete with hardware for fixing to panel.
In case of wall fixing the choice of hardware depends on the wall conditions and should be made by the assembler.

Fianchi di sostegno Support side panels

P Dpt 54,5
Sp Th 1,8



COD. **VF04.52Q**

Fianchi di sostegno Support side panels

P Dpt 54,5
Sp Th 1,8

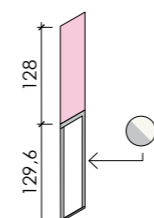

COD. **VF04.04A**

COD. **VF04.05G**

Informazioni tecniche: Technical information:

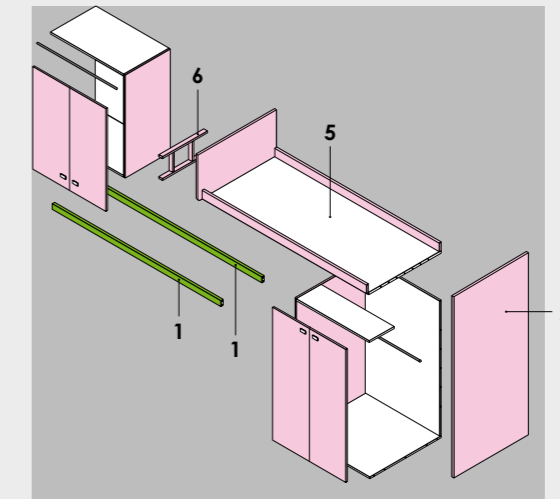

• È indispensabile completare le composizioni con i fianchi di sostegno o gli armadi P 56,3, la protezione e la scaletta in metallo.

- Posizionabili esclusivamente a parete.
- Sono dotati di 1 tubo appendiabiti per vano.
- Il letto è utilizzabile anche senza rete.
- I pannelli retro sono dotati di piedini regolabili.
- Vano ponte H 129,6 - L 208.

• It is absolutely necessary to complete compositions with side support panels or wardrobes Dpt 56.3, guard and the metal ladder.

- Can only be positioned against a wall.
- Each compartment is equipped with 1 clothes hanging rail.
- The bed can be used without bed base.
- Back panels are equipped with adjustable feet.
- Niche of overhead structure Ht 129.6 - W 208.

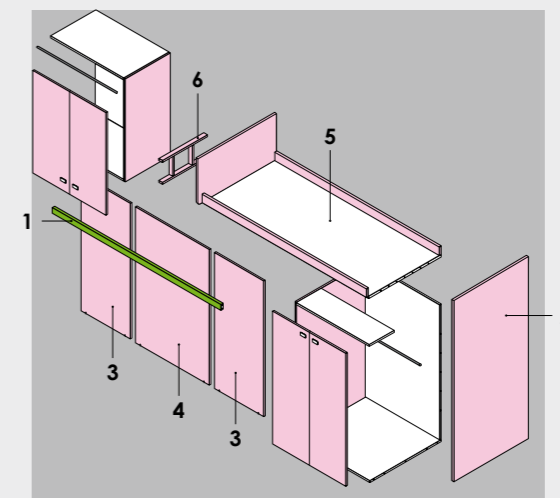

- | | | |
|---|--|--|
| 1 | Barra ponte | Overhead bar |
| 2 | Pediera letto, fianco strutturale armadio P 90 | Bed footboard, structural side wardrobe Dpt 90 |
| 3 | Pannello retro L 59 | Back panel W 59 |
| 4 | Pannello retro L 90 | Back panel W 90 |
| 5 | Interno letto 200,6 x 84,7
Per materasso 190 x 80 | Internal dimension 200.6 x 84.7
For mattress 190 x 80 |
| 6 | Portariviste | Magazine rack |

Protezioni (fisse) Guard (fixed)

WINNER

L W 150
H Ht 35
Sp Th 2,5

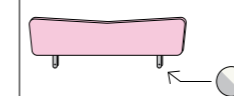

COD. **VF33.17F**

MASCHERA

L W 150
H Ht 24

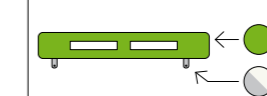

COD. **VF33.18N**

Scaletta in metallo Metal ladder

PEG

L W 35
H Ht 148,7

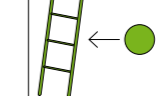

COD. **VF33.19U**

Con fissaggio
With fixing

Sovrapprezzi per rallentatore chiusura:
Surcharge for closing retainer:

+ 9,00 ANTA
DOOR

pag. 42
pag. 106
pag. 150

Posizionamento pomelli e maniglie
Knobs and handles position
Accessori per armadi ponte e letti a soppalco
Overhead wardrobes and loft beds accessories
Reti, materassi e guanciali
Bed bases, mattresses and pillows

Letti a soppalco BRIDGE - H 257,6 P 100 - con scaletta laterale

BRIDGE loft beds - Ht 257.6 Dpt 100 - with side stair

CON 2 BARRE PONTE
WITH 2 OVERHEAD BARS

Specificare Sx o Dx (disegno Dx)
Specify L or R (R drawing)

Elemento soprabarra
Over bar element

Ht **128**

Vano ponte
Niche of overhead structure

Ht **129,6** L **208**

L
W **304,8**

L
W **349,8**

COD.	VF04.70N	VF04.71U	VF04.72A	VF04.73G	VF04.52Q
VOLO	(A)	(B)			

CON PANNELLI RETRO
WITH BACK PANELS

Specificare Sx o Dx (disegno Dx)
Specify L or R (R drawing)

Elemento soprabarra
Over bar element

Ht **128**

Vano ponte
Niche of overhead structure

Ht **129,6** L **208**

L
W **304,8**

L
W **349,8**

COD.	VF04.80T	VF04.81Z	VF04.82F	VF04.83N	VF04.04A VF04.05G
VOLO	(A)	(B)			

Mensola sottoponte
Shelf for use beneath overhead composition

P Dpt **26,5**
Sp Th **2,5**

4 reggimensola
4 shelf holders

208

COD.	Con reggimensola With shelf holders	VF04.22Y
-------------	--	-----------------

CARICO MASSIMO CONSIGLIATO
(al netto delle mensole)
MAXIMUM RECOMMENDED LOAD
(shelves weight excluded)

30 Kg per ogni coppia di reggimensola
for every pair of shelf holders

NB. Il carico si intende uniformemente distribuito sulla mensola. Tra 2 reggimensola ci deve essere una distanza non superiore a 135 cm.

NOTE. Load shall be evenly distributed on the shelf. The maximum distance between 2 shelf holders shall be 135 cm.

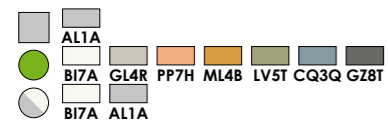

Provisti di ferramenta per fissaggio a pannello.
In caso di fissaggio a muro la scelta del tipo di tassello da utilizzare dovrà essere fatta dal montatore sulla base delle caratteristiche della parete.
Complete with hardware for fixing to panel.
In case of wall fixing the choice of hardware depends on the wall conditions and should be made by the assembler.

Fianchi di sostegno
Support side panels

P Dpt **54,5**
Sp Th **1,8**

COD.					
-------------	--	--	--	--	--

Fianchi di sostegno
Support side panels

P Dpt **54,5**
Sp Th **1,8**

COD.					
-------------	--	--	--	--	--

Informazioni tecniche:
Technical information:

- È indispensabile completare le composizioni con i fianchi di sostegno o gli armadi P 56,3 e la protezione.
- Posizionabili esclusivamente a parete.
- Sono dotati di 1 tubo appendiabiti per vano.
- Il letto è utilizzabile anche senza rete.
- La scaletta è strutturale: non è possibile escluderla.
- I pannelli retro sono dotati di piedini regolabili.
- Vano ponte H 129,6 - L 208.

- It is absolutely necessary to complete compositions with side support panels or wardrobes Dpt 56.3 and guard.
- Can only be positioned against a wall.
- Each compartment is equipped with 1 clothes hanging rail.
- The bed can be used without bed base.
- The stair are part of the structure: they cannot be excluded.
- Back panels are equipped with adjustable feet.
- Niche of overhead structure Ht 129.6 - W 208.

1	Barra ponte	Overhead bar
2	Pediera letto, fianco strutturale armadio P 90 e fianco strutturale scaletta in legno	Bed footboard, structural side wardrobe Dpt 90 and structural side wood stair
3	Pannello retro L 59	Back panel W 59
4	Pannello retro L 90	Back panel W 90
5	Interno letto 200,6 x 84,7 Per materasso 190 x 80	Internal dimension 200.6 x 84.7 For mattress 190 x 80
6	Portariviste	Magazine rack

Protezioni (fisse)
Guard (fixed)

WINNER	MASCHERA
L W 189	L W 183
H Ht 35	H Ht 24
Sp Th 2,5	

COD.					
	(A)	(B)			

Sovrapprezzi per rallentatore chiusura:
Surcharge for closing retainer:

ANTA DOOR

pag. **42**
pag. **106**
pag. **150**

Posizionamento pomelli e maniglie
Knobs and handles position
Accessori per armadi ponte e letti a soppalco
Overhead wardrobes and loft beds accessories
Reti, materassi e guanciali
Bed bases, mattresses and pillows

Accessori per armadi ponte e letti a soppalco

Bridge wardrobes and loft beds accessories

ACCESSORI PER ARMADI PONTE

BRIDGE WARDROBES ACCESSORIES

Ripiani interni

Inner shelves

Sp	Th	2,5
P	Dpt	51,5
L	W	43,1 58,1 88,1

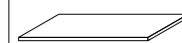

Tubi appendiabiti

Clothes hanging rails

L	W	43,1 58,1 88,1
---	---	----------------------

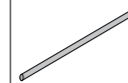

L W	COD.	COD.
45	VF32.80U	VF32.86H
60	VF32.81A	VF32.87Q
90	VF32.82G	VF32.88W

ACCESSORI PER LETTI A SOPPALCO

LOFT BEDS ACCESSORIES

Ripiani interni

Inner shelves

Sp	Th	2,5
P	Dpt	51,5
L	W	43,1 88,1

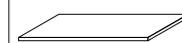

Ripiani interni

Inner shelves

Sp	Th	2,5
P	Dpt	29,2
L	W	45 90

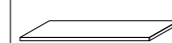

Per amadio P 90
For wardrobe Dpt 90

Tubi appendiabiti

Clothes hanging rails

L	W	43,1 88,1
---	---	--------------

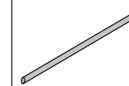

L	W	45 90
---	---	----------

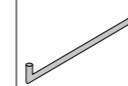

Per amadio P 90
For wardrobe Dpt 90

Reti a doghe

Slatted bed bases

L	W	80
P	Dpt	190

Avvolgibile
Roll-up



L	W	80
P	Dpt	190



L W	COD.	COD.	COD.	COD.	COD.	COD.
45	VF32.80U	VF33.12Y	VF32.86H	VF33.14M		
90	VF32.82G	VF33.13E	VF32.88W	VF33.15T	VF33.20R	VF33.66B

ACCESSORI COMUNI

SHARED ACCESSORIES

Saliscendi per abiti

Slide rail for clothes

H	Ht	84
---	----	----

Per elementi soprabarra L 90
For over-bar elements W 90

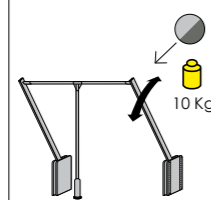

Bastone prendi abito

Reacher pole

H	Ht	115
---	----	-----

In metallo
Metal

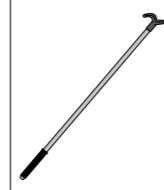

COD.	COD.	COD.
	VF32.89C	VF32.97V

Letti a castello WINNER - H 187 L 101,5 - per scaletta in metallo

WINNER bunk beds - Ht 187 W 101.5 - for metal ladder

Letti a castello WINNER - H 187 L 101,5 - con scaletta laterale

WINNER bunk beds - Ht 187 W 101.5 - with side stair

Rele estraibile L 80 (materasso H 12 max).
Pull-out bed base W 80 (mattress Ht 12 max).

Rele estraibile L 80 (materasso H 12 max).
Pull-out bed base W 80 (mattress Ht 12 max).

P Dpt **200**

P Dpt **247,5**

rete L bed base W	COD.	interno letto internal dimensions	COD.	interno letto internal dimensions	COD.	interno letto internal dimensions
90	VF04.90Y	91,5 x 194	VF04.91E	91,5 x 194	VF04.92M	91,5 x 194

rete L bed base W	COD.	interno letto internal dimensions	COD.	interno letto internal dimensions	COD.	interno letto internal dimensions
90	VF04.93T	91,5 x 194	VF04.94Z	91,5 x 194	VF04.95F	91,5 x 194

Protezioni (fisse) Guard (fixed)

WINNER

L W 150
H Ht 35
Sp Th 2,5

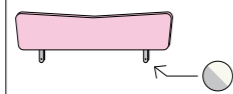

MASCHERA

L W 150
H Ht 24

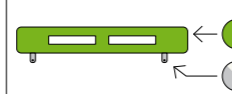

Scaletta in metallo Metal ladder

PEG

L W 35
H Ht 148,7



Con fissaggio
With fixing

COD.	VF33.17F	VF33.18N	VF33.19U
(A)			
(B)			

Protezioni (fisse) Guard (fixed)

WINNER

L W 189
H Ht 35
Sp Th 2,5

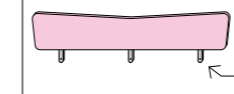

MASCHERA

L W 183
H Ht 24

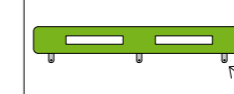

COD.	VF33.22D	VF33.23L
(A)		
(B)		

Informazioni tecniche: Technical information:

- È obbligatorio ordinare 1 o più protezioni e la scaletta in metallo PEG.
- 1 or more guards and the PEG metal ladder must be ordered.

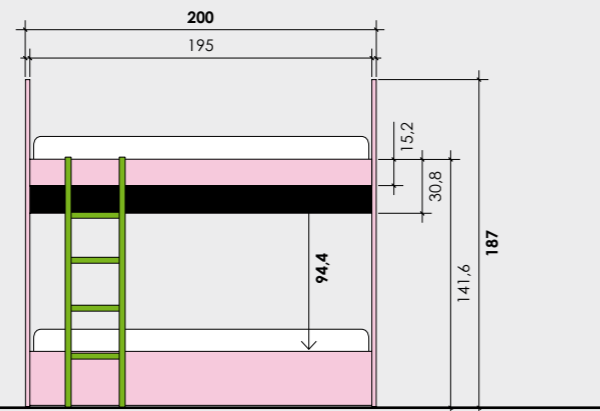

Pavimento
Floor

Informazioni tecniche: Technical information:

Esempio Sx
Left example

- È obbligatorio ordinare 1 o più protezioni.
- La scaletta è strutturale: non è possibile escluderla.
- 1 or more guards must be ordered.
- The stair are part of the structure: they cannot be excluded.

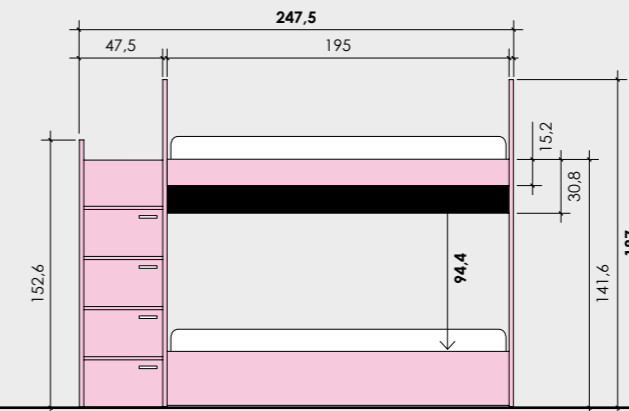

Pavimento
Floor

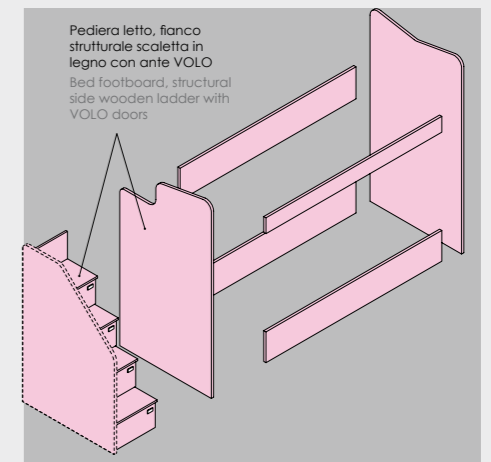

Accessori Accessories

Materasso in spugna Foam mattress

L W 81,5
P Dpt 189
H Ht 12

per rete inferiore estraibile
for pull-out lower base
con fodera
with cover

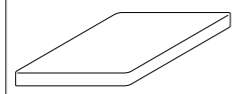

COD.	VF33.24S

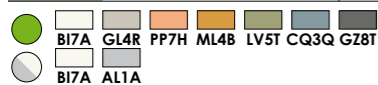

Accessori Accessories

Materasso in spugna Foam mattress

L W 81,5
P Dpt 189
H Ht 12

per rete inferiore estraibile
for pull-out lower base
con fodera
with cover

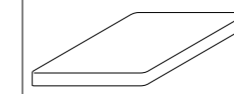

COD.	VF33.24S	172,00

Sovrapprezzi per rallentatore chiusura:
Surcharge for closing retainer:

ANTA
DOOR

pag. 42
pag. 150

Posizionamento pomelli e maniglie
Knobs and handles position
Reti, materassi e guanciali
Bed bases, mattresses and pillows

Letti a castello REVOLUTION - H 198 L 210

REVOLUTION bunk beds - Ht 198 W 210

- In fase di ordinazione è necessario aggiungere: una scaletta metallica o con fianchi sagomati e una protezione.
- Posizionabili esclusivamente a parete.
- Volta colore Rovere white (RW3Q).
- Rete a doghe strutturale L 90 o 120 P 205 (per materasso L 90 o 120 P 200).
- I disegni rappresentano i letti a castello P 127,3.

- When ordering, the metal ladder or the ladders with shaped sides and one or more guards have to be added.
- Positionable exclusively on the wall.
- Hidden base support in Rovere white (RW3Q) colour.
- Wooden slatted structural base W 90 or 120 Dpt 205 (for mattress W 90 or 120 Dpt 200).
- The drawings represent the bunk beds Dpt 127,3.

Fianchi REVOLUTION
REVOLUTION side panel

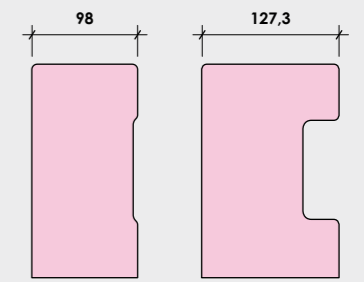

Vano per letto
L 205 H 151,5
Niche for bed
W 205 Ht 151,5

- Vuoto
Empty
- Con mensole
With shelves
- Con letti scorrevoli TRIS
With TRIS sliding beds
- Con scrivania e letto scorrevoli TRIS
With TRIS sliding desk and bed

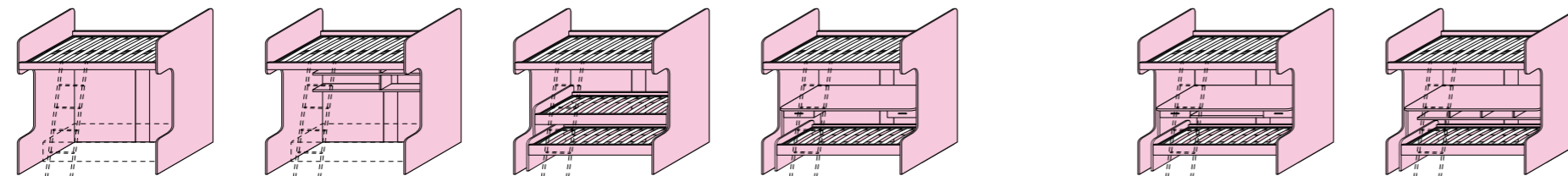

P Dpt 98
Rete superiore L 90
Upper bed base W 90

COD. VF05.00D VF05.01L VF05.02S VF05.03Y VF05.04E VF05.05M

(A)
(B)

P Dpt 127,3
Rete superiore L 120
Upper bed base W 120

COD. VF05.10K VF05.11R VF05.12X VF05.13D VF05.14L VF05.15S

(A)
(B)

Vano per letto
L 205 H 151,5
Niche for bed
W 205 Ht 151,5

Specificare Sx o Dx
(disegni Dx)
Specify L or R
(drawings R)

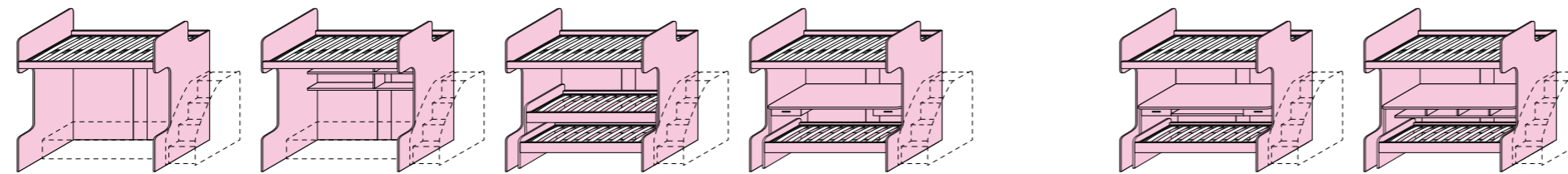

P Dpt 98
Rete superiore L 90
Upper bed base W 90

COD. VF05.20Q VF05.21W VF05.22C VF05.23K VF05.24R VF05.25X

(A)
(B)

P Dpt 127,3
Rete superiore L 120
Upper bed base W 120

COD. VF05.30V VF05.31B VF05.32H VF05.33Q VF05.34W VF05.35C

(A)
(B)

Mensole
Shelves

L W 205
P Dpt 30,8
H Ht 49

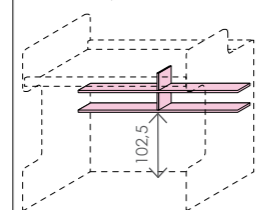

Scrittoi TRIS con ruote anteriori con freno
TRIS writing-desk with wheels with brake at front

Con 2 cassetti
With 2 drawers

L W 202,6
P Dpt 88,5
H Ht 71

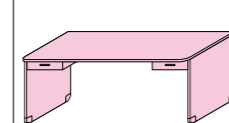

Con 2 cassetti e piano
With 2 drawers and top

L W 202,6
P Dpt 88,5
H Ht 71

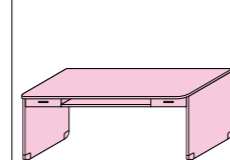

Con elemento sottopiano
With element below top

L W 202,6
P Dpt 88,5
H Ht 71

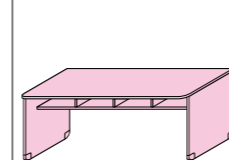

Letti TRIS con ruote autofrenanti
TRIS beds with self-braking wheels

Inferiore
Bottom

L W 196,4
P Dpt 89,8
H Ht 36

Rete L 80 (materasso L 80 x 190)
Bed base W 80 (mattress W 80 x 190)

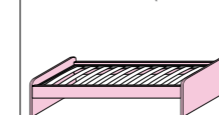

Centrale
Central

L W 202,2
P Dpt 93
H Ht 71

Rete L 80 (materasso L 80 x 190)
Bed base W 80 (mattress W 80 x 190)

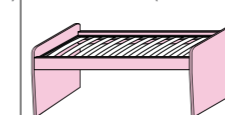

COD. VF33.31C

(A)
(B)

COD. VF33.27M

COD. VF33.28T

COD. VF33.29Z

COD. VF33.25Y

COD. VF33.26E

Sovrapprezzi per rallentatore chiusura:
Surcharge for closing retainer:

CASSETTO
DRAWER

pag. 42
pag. 116
pag. 150

Posizionamento pomelli e maniglie
Knobs and handles position
Accessori per letti a castello REVOLUTION
REVOLUTION bunk beds accessories
Reti, materassi e guanciali
Bed bases, mattresses and pillows

Letti a castello REVOLUTION - H 198 L 210 - con cabina

REVOLUTION bunk beds - Ht 198 W 210 - with walk-in wardrobe

- In fase di ordinazione è necessario aggiungere: una scaletta metallica o con fianchi sagomati e una protezione.
- Posizionabili esclusivamente a parete.
- Sono dotati di 1 tubo appendiabiti per vano.
- Volta colore Rovere white (RW3Q).
- Rete a doghe strutturale L 90 o 120 P 205 (per materasso L 90 o 120 P 200).
- Apertura ante a soffietto.
- I disegni rappresentano i letti a castello P 127,3.

- When ordering, the metal ladder or the ladders with shaped sides and one or more guards have to be added.
- Positionable exclusively on the wall.
- Each compartment is equipped with 1 clothes hanging rail.
- Hidden base support in Rovere white (RW3Q) colour.
- Wooden slatted structural base W 90 or 120 Dpt 205 (for mattress W 90 or 120 Dpt 200).
- Doors with folding opening.
- The drawings represent the bunk beds Dpt 127,3.

Fianchi REVOLUTION
REVOLUTION side panel

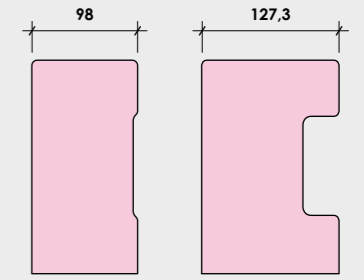

Vano per letto
L 205 H 151,5
Niche for bed
W 205 Ht 151,5

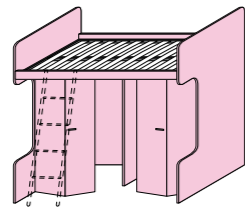

P Dpt 98 Rete superiore L 90 Upper bed base W 90	COD. VF05.06T
	VOLO (A) (B)
P Dpt 127,3 Rete superiore L 120 Upper bed base W 120	COD. VF05.16Y
	VOLO (A) (B)

Vano per letto
L 205 H 151,5
Niche for bed
W 205 Ht 151,5

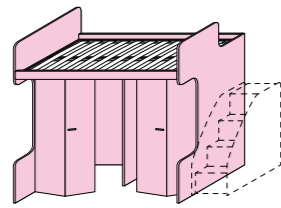

Specificare Sx o Dx (disegni Dx)
Specify L or R (drawings R)

P Dpt 98 Rete superiore L 90 Upper bed base W 90	COD. VF05.26D
	VOLO (A) (B)
P Dpt 127,3 Rete superiore L 120 Upper bed base W 120	COD. VF05.36K
	VOLO (A) (B)

Cabina REVOLUTION
REVOLUTION walk-in wardrobes

Esempio con quote e completo di attrezzatura interna (ripiano interno L 101,2 e cassetiera interna L 90)
Example with heights and complete with internal equipment (internal shelf L 101,2 and internal chest of drawers L 90)

- a Tubo appendiabiti
Clothes hanging rail
- b Tramezzo
Partition
- c Ripiano interno
Inner shelves
- d Cassetiera interna
Inner chests of drawers

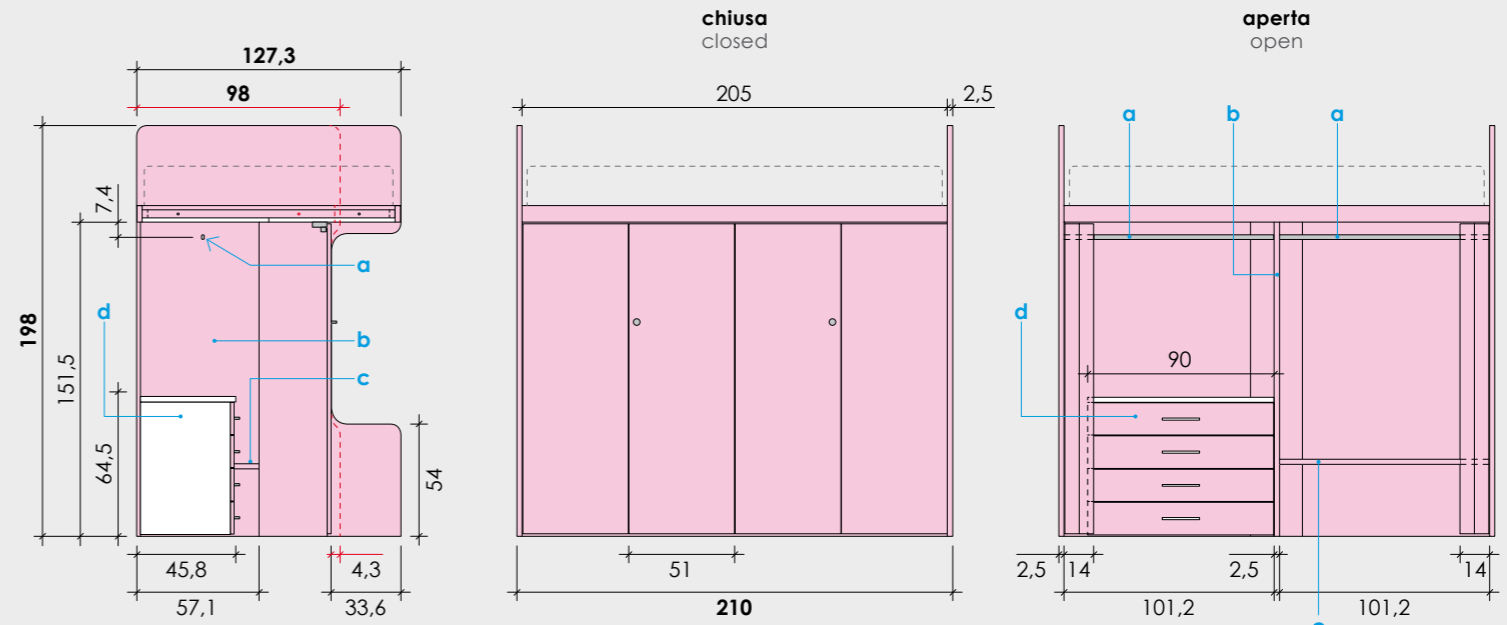

Armadi ponte, Letti a
soppalco e a castello
Bidge wardrobes,
Loft and bunk beds

Ripiano interno
Inner shelf
L W 101,2
P Dpt 57,1
Sp Th 2,5

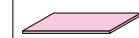

Cassettiere interne L 90 - P 45,8
Inner chests of drawers W 90 - Dpt 45,8

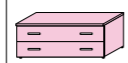

H Ht 67



H Ht 99

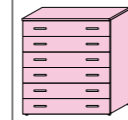

COD.	VF33.57C	VF33.58K	VF33.59R	VF33.60N
	(A) (B)			

Tubo appendiabiti
Clothes hanging rail

L W 101,2



VF33.61U

Sovrapprezzi per rallentatore chiusura:
Surcharge for closing retainer:

+ 13,00 **CASSETTO**
DRAWER

pag. 42
pag. 116
pag. 150

Posizionamento pomelli e maniglie
Knobs and handles position
Accessori per letti a castello
REVOLUTION bunk beds accessories
Reti, materassi e guanciali
Bed bases, mattresses and pillows

Letti a castello REVOLUTION - H 198 L 210 - con armadio

REVOLUTION bunk beds - Ht 198 W 210 - with wardrobe

- In fase di ordinazione è necessario aggiungere: una scaletta metallica o con fianchi sagomati e una protezione.
 - Posizionabili esclusivamente a parete.
 - Sono dotati di 1 tubo appendiabiti.
 - Gli armadi inseriti sotto il letto sopralco sono P 93,6.
 - Volta colore Rovere white (RW3G).
 - Rete a doghe strutturale L 90 o 120 P 205 (per materasso L 90 o 120 P 200).
 - I disegni rappresentano i letti a castello P 127,3.
- When ordering, the metal ladder or the ladders with shaped sides and one or more guards have to be added.
 - Positionable exclusively on the wall.
 - Each compartment is equipped with 1 clothes hanging rail.
 - Wardrobes inserted underneath platform beds are Dpt 93.7 cm.
 - Hidden base support in Rovere white (RW3G) colour.
 - Wooden slatted structural base W 90 or 120 Dpt 205 (for mattress W 90 or 120 Dpt 200).
 - The drawings represent the bunk beds Dpt 127.3.

Fianchi REVOLUTION
REVOLUTION side panel

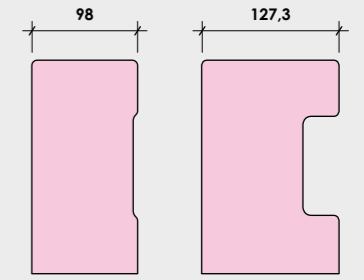

Vuoto
Empty

Con piano fisso
With fixed plane

Con anta ribalta
With pull-down door

Vano per letto
L 102,5 H 151,5
Niche for bed
W 102.5 Ht 151.5

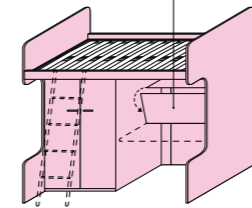
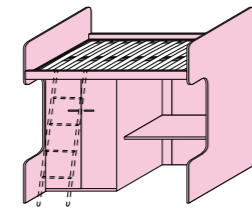
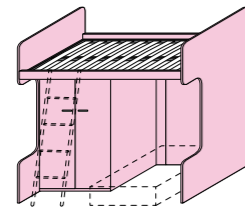

L'anta aperta ha la
funzione di piano scrittoio.
The open door has the
writing desk function.

PORTATA MASSIMA
MAXIMUM CAPACITY
10 Kg

P Dpt **98**
Rete superiore L 90
Upper bed base W 90

COD. VF05.07Z VF05.08F VF05.09N

VOLO (A) (B)

P Dpt **127,3**
Rete superiore L 120
Upper bed base W 120

COD. VF05.17E VF05.18M VF05.19T

VOLO (A) (B)

Vano per letto
L 102,5 H 151,5
Niche for bed
W 102.5 Ht 151.5

Specificare Sx o Dx
(disegni Dx)
Specify L or R
(drawings R)

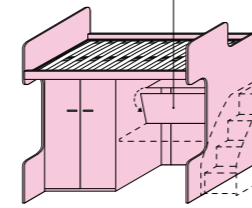
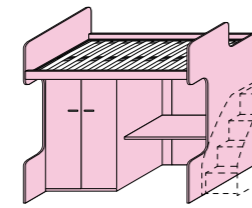
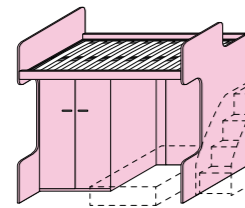

L'anta aperta ha la
funzione di piano scrittoio.
The open door has the
writing desk function.

PORTATA MASSIMA
MAXIMUM CAPACITY
10 Kg

P Dpt **98**
Rete superiore L 90
Upper bed base W 90

COD. VF05.27L VF05.28S VF05.29Y

VOLO (A) (B)

P Dpt **127,3**
Rete superiore L 120
Upper bed base W 120

COD. VF05.37R VF05.38X VF05.39D

VOLO (A) (B)

Ripiano interno
Inner shelf
L W 98,8
P Dpt 51,5
Sp Th 2,5

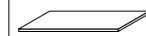

Tubo appendiabiti
Clothes hanging rail
L W 98,8

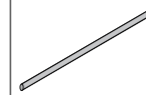

COD. VF33.62A

COD. VF33.65V

ALTA
Frontali disponibili con apertura PUSH-PULL
Fronts available with PUSH-PULL opening

Sovrapprezzi per rallentatore chiusura:
Surcharge for closing retainer:

ANTA
DOOR

pag. 42
pag. 116
pag. 150

Posizionamento pomelli e maniglie
Knobs and handles position
Accessori per letti a castello REVOLUTION
REVOLUTION bunk beds accessories
Reti, materassi e guanciali
Bed bases, mattresses and pillows

Accessori per letti a castello REVOLUTION

REVOLUTION bunk beds accessories

Scaletta in metallo MAO

MAO metal ladder

con fissaggio
with fixing

L W 35
H Ht 162,8

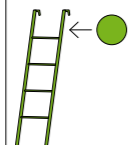

COD. VF33.32K

Scalette con fianchi sagomati LEA

LEA ladders with shaped side panels

con ante
with doors

L W 50
P Dpt 105,3
H Ht 120

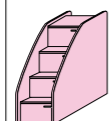

con ante e corrimano
with doors and handrail

L W 54
P Dpt 105,3
H Ht 184,3

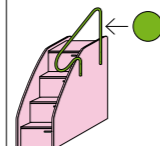

Corrimano per LEA

Handrail for LEA

Ø 3,2
P Dpt 92
H Ht 100

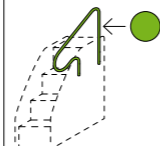

Specificare cerniera Sx o Dx
(disegno Sx)
Specify hinge L or R
(drawing L)

COD. VF35.08R

COD. VF35.09X

COD. VF35.10U

VOLO ^A
_B

Protezioni per scaletta MAO

Guards for MAO ladder

SHAPE

L W 163
H Ht 38

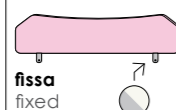

fissa
fixed



reclinabile
reclining

Protezioni per scaletta LEA

Guards for LEA ladder

SHAPE

L W 204
H Ht 38

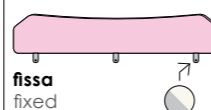

fissa
fixed



reclinabile
reclining

COD. VF33.36L

COD. VF33.38Y

COD. VF33.35D

COD. VF33.37S

VOLO ^A
_B

Lampada led SPARK

SPARK led lighting

Ø 9,1
H Ht 4,4

Interruttore manuale o sensore di luce azionabile con interruttore laterale. Applicabile con le viti fornite o con velcro biadesivo. 3 batterie da 1,5v AAA non incluse.

Manual switch or light sensor that can be operated with the side switch. Applied with the provided screws or with biadhesive Velcro. 3 - 1.5v AAA batteries not included.



COD. VF32.59M

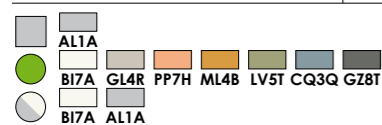

Sovrapprezzi per rallentatore chiusura:
Surcharge for closing retainer:

ANTA
DOOR

Letti a castello TITANO - H 179,3 L 200

TITANO bunk beds - Ht 179.3 W 200

- Letto superiore L 80 (per materasso L 80 P 190).
- Il letto superiore è utilizzabile anche senza rete.
- In fase di ordinazione è necessario aggiungere: una scaletta metallica o con fianchi sagomati, una o più protezioni.
- Retrofiniti, posizionabili anche a centro stanza.
- Volta colore Rovere white (RW3Q).

- Upper bed W 80 (for mattress W 80 Dpt 190).
- The upper bed can also be used without a bed base.
- When ordering, a metal ladder or the ladders with shaped sides and one or more guards have to be added.
- With finished back panel, can also be placed in centre of room.
- Hidden base support in Rovere white (RW3Q) colour.

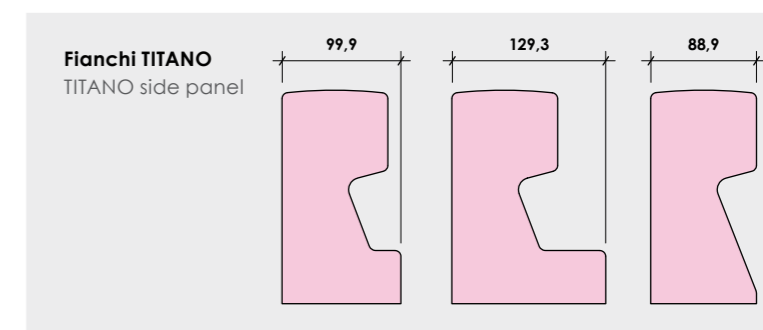

2 reti
2 bed bases

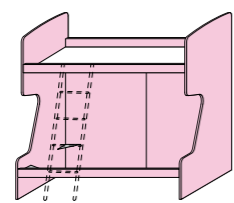

Con rete estraibile
materasso L 80 H 17 max
With extractable bed base
mattress W 80 Ht 17 max

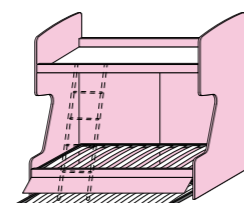

Con cassettoni
With big drawers

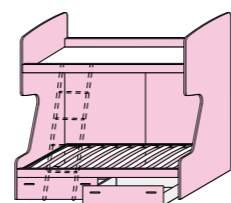

Vuoto
Empty

Vano L 195 H 131,1
Niche W 195 Ht 131,1

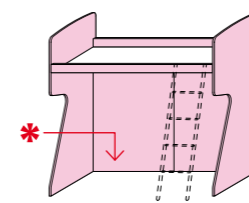

PEG
scaletta
in metallo
metal ladder

con fissaggio
with fixing
L W 35
H Ht 148,7

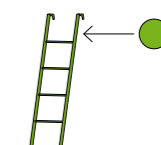

P Dpt 99,9

COD. VF05.40A

A
B

Rete inferiore L 90 x 190
Bottom bed base W 90 x 190

COD. VF05.41G

COD. VF05.42P

P Dpt 88,9

COD. VF05.55P

A
B

COD. VF33.19U

Specificare Sx o Dx
(disegni Dx)
Specify L or R
(drawings R)

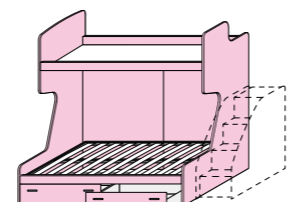
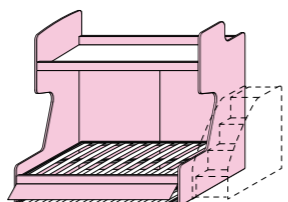
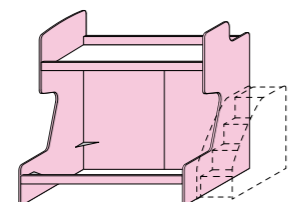

P Dpt 99,9

COD. VF05.45H

A
B

Rete inferiore L 90 x 190
Bottom bed base W 90 x 190

COD. VF05.46Q

COD. VF05.47W

P Dpt 129,3

COD. VF05.50F

A
B

Rete inferiore L 120 x 190
Bottom bed base W 120 x 190

COD. VF05.51N

COD. VF05.52U

Vano L 195 H 131,1
Niche W 195 Ht 131,1

Specificare Sx o Dx
(disegni Dx)
Specify L or R
(drawings R)

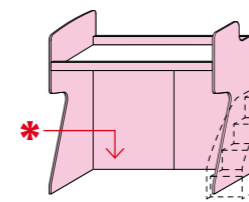

P Dpt 88,9

COD. VF05.56V

A
B

LEA
scalette con fianchi
sagomati
ladders with shaped
side panels

con ante
with doors
L W 50
P Dpt 105,3
H Ht 120

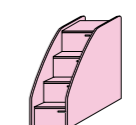

con ante
e corrimano
with doors
and handrail
L W 54
P Dpt 105,3
H Ht 184,3

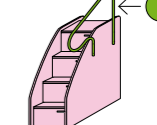

COD. VF35.08R

COD. VF35.09X

VOLO A
B

Giroletti metallici *
Metal bed frames

L W 88
P Dpt 193
H Ht 29

Con 4 ruote piroettanti con freno
With 4 turning wheels with brake

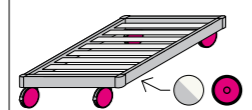

COD. VF33.69W

Con 4 piedi cilindrici trasparenti
With 4 transparent cylindrical feet

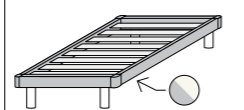

COD. VF33.70T

Corrimano per LEA
Handrail for LEA

Ø 3,2
P Dpt 92
H Ht 100

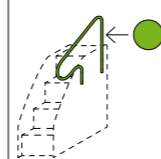

COD. VF35.10U

Protezioni (fisse) per scaletta PEG
Guards (fixed) for PEG ladder

WINNER
L W 150
H Ht 35
Sp Ht 2,5

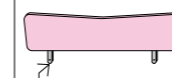

COD. VF33.17F

A
B

MASCHERA
L W 150
H Ht 24

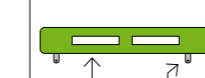

COD. VF33.18N

Protezioni (fisse) per scaletta LEA
Guards (fixed) for LEA ladder

WINNER
L W 189
H Ht 35
Sp Ht 2,5

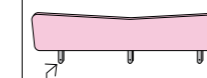

COD. VF33.22D

MASCHERA
L W 183
H Ht 24

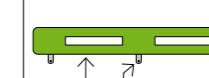

COD. VF33.23L

Sovrapprezzi per rallentatore chiusura:
Surcharge for closing retainer:

ANTA
DOOR

pag. 42
pag. 150

Posizionamento pomelli e maniglie
Knobs and handles position
Reti, materassi e guanciali
Bed bases, mattresses and pillows

Facciate Fronts
VOLO

Finiture GRUPPO 1
GROUP 1 finishes

Finiture GRUPPO 2
GROUP 2 finishes

Rovere white*

Rovere white
RW3Q

Noce brina
NB5T

Bianco opaco
B17A

Grigio Dorian
GL4R

Cemento artico
CA7A

Rovere gesso
RG9L

Royal oak
RS4B

Rovere cognac
RC3Q

Grigio titanio
GZ8T

Papaya
PP7H

Miele
ML4B

Oliva
LV5T

Cadaques
CQ3Q

Vetri Glass

Ante Doors
WINDOW

Colori telaio
Frame colours

Trasparente
TR9M

Trasparente fumé
FT8P

Stop sol
ST6P

Specchio
SP7L

Alluminio
AL1A

Titan grey
TG7H

Rovere white* Finitura unica per tutti i componenti in pannello presenti a listino non evidenziati con il colore Finiture GRUPPO 1 e/o Finiture GRUPPO 2.
Unique finish for all the panel components shown in the pricelist not highlighted with the color finishes GROUP 1 and/or finishes GROUP 2.

- A** Finiture in fascia di prezzo A
Finishes in price range A
- B** Finiture in fascia di prezzo B
Finishes in price range B
- ☆** Finiture con effetto materico
Finishes with textured effect

LETTI E GRUPPI
BEDS AND GROUPS

Letti singoli Single beds	pag. 122
Letti singoli imbottiti Padded single beds	pag. 130
Turche Ottomans	pag. 132
Divani letto Sofa beds	pag. 134
Giroletti metallici Beds with metal frame	pag. 135
Letti matrimoniali Double beds	pag. 136
Letti matrimoniali imbottiti Padded double beds	pag. 144
Letti scorrevoli NEW ROLL NEW ROLL sliding beds	pag. 146
Letti scorrevoli EDGE EDGE sliding beds	pag. 147
Letti scorrevoli SPIKE SPIKE sliding beds	pag. 148
Accessori per letti Beds accessories	pag. 149
Reti, materassi e guanciali Bed bases, mattresses and pillows	pag. 150
Gruppi Groups	pag. 154
Specchiere Mirrors	pag. 156

Tutte le misure sono espresse in centimetri; con tolleranza ± 2 cm per gli imbottiti.
I pesi massimi consigliati dei materassi per letti con rete alzante, sono indicati nella tabella a fianco.

All measurements are expressed in centimeters; with tolerance ± 2 cm for upholstered items.
The recommended maximum weights of mattresses for beds with lift-up bed base are shown in the table alongside.

Larghezza rete alzante Lifting bed base width	Peso max materasso Max mattress weight
80 - 90	20 Kg
120	30 Kg
140 - 150	35 Kg
160 - 180	40 Kg
200	45 Kg



Con testata e pediera
With headboard and footboard

Con due reti
With two bed bases

Con rete e cassettoni
With bed base and big drawers

Con rete rialzabile
With lifting base

Con giroletto legno
With wooden bed frame

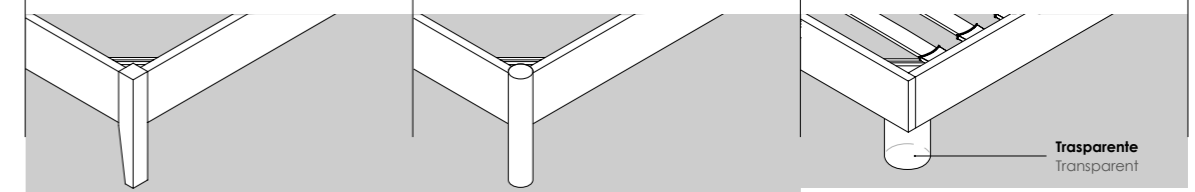

BANNER

Sp Th 1,8

H Ht 90
P Dpt 195,6
205,6
L W 91
101
131

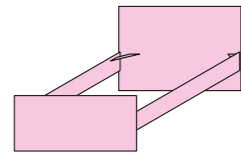

H Ht 90
P Dpt 198,6
-
L W 91
101
131

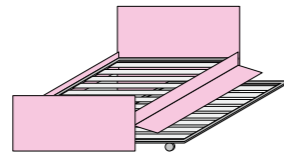

H Ht 90
P Dpt 198,6
-
L W 91
101
131

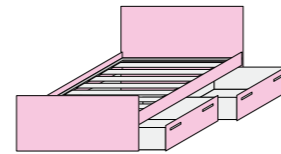

H Ht 90
P Dpt 200,6
-
L W 101
131

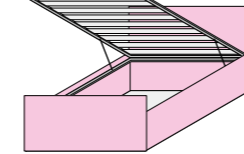

H Ht 90
P Dpt 198,8
208,8
L W 91
101
131

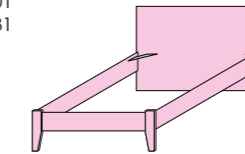

H Ht 90
P Dpt 198,3
208,3
L W 91
101
131

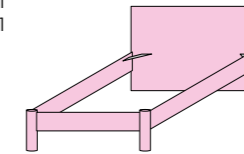

H Ht 90
P Dpt 198,3
208,3
L W 91
101
131

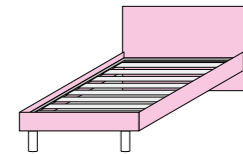

H Ht 90
P Dpt 198,6
-
L W 91
101
131

rete L bed base W	COD.	interno letto internal dimensions	COD.	interno letto internal dimensions	COD.	interno letto internal dimensions	COD.	interno letto internal dimensions	COD.	interno letto internal dimensions	COD.	interno letto internal dimensions	COD.	interno letto internal dimensions
80 x 190	VF20.00P	81,5 x 191	VF20.03H	81,5 x 194	VF20.06C	81,5 x 194	-	-	VF20.11A	81,5 x 191,5	VF25.50N	81,5 x 191,5	VF20.17Q	82,7 x 195
90 x 190 200	VF20.01V	91,5 x 191 91,5 x 201	VF20.04Q	91,5 x 194 -	VF20.07K	91,5 x 194 -	VF20.09X	91,5 x 195 -	VF20.12G	91,5 x 191,5 91,5 x 201,5	VF25.51U	91,5 x 191,5 91,5 x 201,5	VF20.18W	92,7 x 195 -
120 x 190 200	VF20.02B	121,5 x 191 121,5 x 201	VF20.05W	121,5 x 194 -	VF20.08R	121,5 x 194 -	VF20.10U	121,5 x 195 -	VF20.13P	121,5 x 191,5 121,5 x 201,5	VF25.52A	121,5 x 191,5 121,5 x 201,5	VF20.19C	122,1 x 195 -

EDGE

Sp Th 2,5

H Ht 120
P Dpt 197
207
L W 90
100
129,4

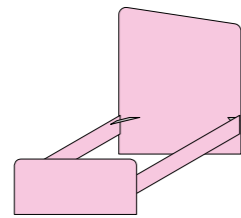

H Ht 120
P Dpt 200
-
L W 90
100
129,4

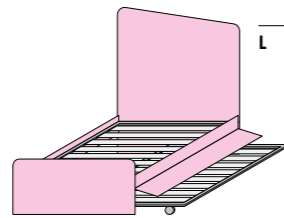

H Ht 120
P Dpt 200
-
L W 90
100
129,4

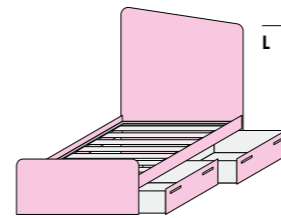

H Ht 120
P Dpt 202
-
L W 100
129,4

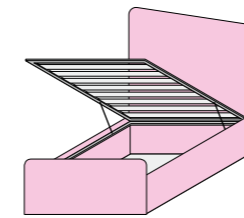

H Ht 120
P Dpt 199,5
209,5
L W 90
100
129,4

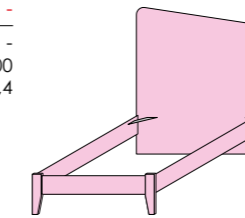

H Ht 120
P Dpt 199
209
L W 90,7
100,7
130,1

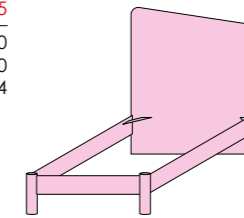

H Ht 120
P Dpt 199,3
-
L W 90
100
129,4

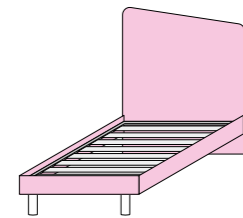

H Ht 120
P Dpt 199,3
-
L W 90
100
129,4

rete L bed base W	COD.	interno letto internal dimensions	COD.	interno letto internal dimensions	COD.	interno letto internal dimensions	COD.	interno letto internal dimensions	COD.	interno letto internal dimensions	COD.	interno letto internal dimensions	COD.	interno letto internal dimensions
80 x 190	VF20.20Z	81,5 x 191	VF20.23U	81,5 x 194	VF20.26P	81,5 x 194	-	-	VF20.31M	81,5 x 191,5	VF25.53G	81,5 x 191,5	VF20.37A	82,7 x 195
90 x 190 200	VF20.21F	91,5 x 191 91,5 x 201	VF20.24A	91,5 x 194 -	VF20.27V	91,5 x 194 -	VF20.29H	91,5 x 195 -	VF20.32T	91,5 x 191,5 91,5 x 201,5	VF25.54P	91,5 x 191,5 91,5 x 201,5	VF20.38G	92,7 x 195 -
120 x 190 200	VF20.22N	121,5 x 191 121,5 x 201	VF20.25G	121,5 x 194 -	VF20.28B	121,5 x 194 -	VF20.30E	953,00 121,5 x 195 -	VF20.33Z	121,5 x 191,5 121,5 x 201,5	VF25.55V	121,5 x 191,5 121,5 x 201,5	VF20.39P	122,1 x 195 -

EDGE PLUS

Sp Th 2,5

Mensole L 30 P 26
Shelves W 30 Dpt 26

H Ht 120
P Dpt 197
207
L W 120
130
159,4

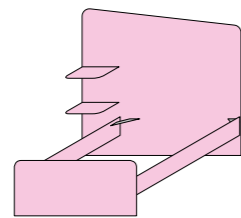

H Ht 120
P Dpt 200
-
L W 120
130
159,4

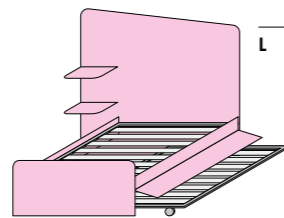

H Ht 120
P Dpt 200
-
L W 120
130
159,4

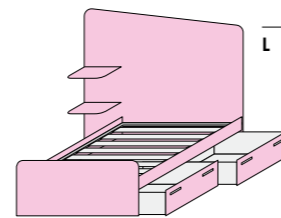

H Ht 120
P Dpt 202
-
L W 130
159,4

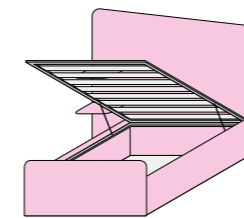

H Ht 120
P Dpt 199,5
209,5
L W 120
130
159,4

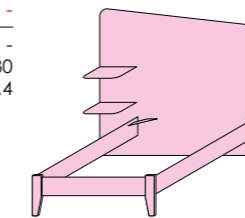

H Ht 120
P Dpt 199
209
L W 120
130
159,4

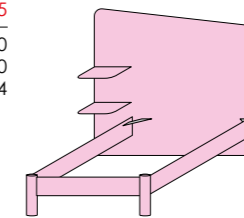

H Ht 120
P Dpt 199,3
-
L W 120
130
159,4

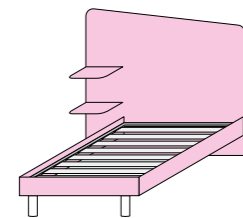

H Ht 120
P Dpt 199,3
-
L W 120
130
159,4

rete L bed base W	COD.	interno letto internal dimensions	COD.	interno letto internal dimensions	COD.	interno letto internal dimensions	COD.	interno letto internal dimensions	COD.	interno letto internal dimensions	COD.	interno letto internal dimensions	COD.	interno letto internal dimensions
80 x 190	VF20.40L	81,5 x 191	VF20.43E	81,5 x 194	VF20.46Z	81,5 x 194	-	-	VF20.51X	81,5 x 191,5	VF25.56B	81,5 x 191,5	VF20.57M	82,7 x 195
90 x 190 200	VF20.41S	91,5 x 191 91,5 x 201	VF20.44M	91,5 x 194 -	VF20.47F	91,5 x 194 -	VF20.49U	91,5 x 195 -	VF20.52D	91,5 x 191,5 91,5 x 201,5	VF25.57H	91,5 x 191,5 91,5 x 201,5	VF20.58T	92,7 x 195 -
120 x 190 200	VF20.42Y	121,5 x 191 121,5 x 201	VF20.45T	121,5 x 194 -	VF20.48N	121,5 x 194 -	VF20.50R	121,5 x 195 -	VF20.53L	121,5 x 191,5 121,5 x 201,5	VF25.58Q	121,5 x 191,5 121,5 x 201,5	VF20.59Z	122,1 x 195 -

In fase d'ordine specificare per rete P 190 o 200.
When ordering, specify for bed base Dpt 190 or 200.

pag. 42
pag. 149
pag. 150

Posizionamento pomelli e maniglie
Knobs and handles position
Accessori per letti
Beds accessories
Reti, materassi e guanciali
Bed bases, mattresses and pillows



Con testata e pediera
With headboard and footboard

Con due reti
With two bed bases

Con rete e cassettoni
With bed base and big drawers

Con rete rialzabile
With lifting base

Con giroletto legno
With wooden bed frame

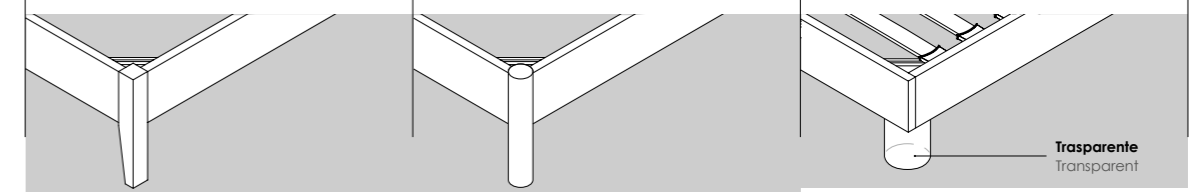

FOLDER

Sp Th 2,5

H Ht 85
P Dpt 197
207
L W 91
101
131

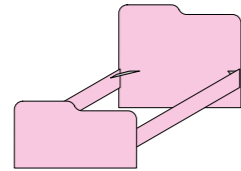

H Ht 85
P Dpt 200
-
L W 91
101
131

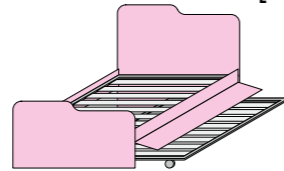

H Ht 85
P Dpt 200
-
L W 91
101
131

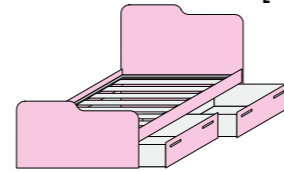

H Ht 85
P Dpt 202
-
L W 101
131

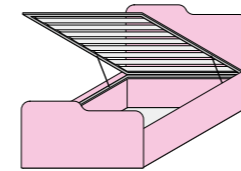

H Ht 85
P Dpt 199,5
209,5
L W 91
101
131

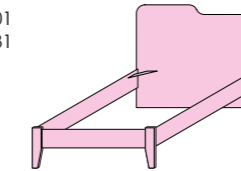

H Ht 85
P Dpt 199
209
L W 91
101
131

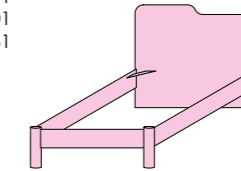

H Ht 85
P Dpt 199,3
-
L W 91
101
131

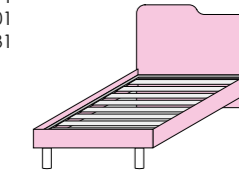

rete L bed base W	COD.	interno letto internal dimensions	COD.	interno letto internal dimensions	COD.	interno letto internal dimensions	COD.	interno letto internal dimensions	COD.	interno letto internal dimensions	COD.	interno letto internal dimensions
80 x 190	VF20.60W	81,5 x 191	VF20.63R	81,5 x 194	VF20.66L	81,5 x 194	-	-	VF20.71H	81,5 x 191,5	VF25.59W	81,5 x 191,5
90 x 190 200	VF20.61C	91,5 x 191 91,5 x 201	VF20.64X	91,5 x 194 -	VF20.67S	91,5 x 194 -	VF20.69E	91,5 x 195 -	VF20.72Q	91,5 x 191,5 91,5 x 201,5	VF25.60T	91,5 x 191,5 91,5 x 201,5
120 x 190 200	VF20.62K	121,5 x 191 121,5 x 201	VF20.65D	121,5 x 194 -	VF20.68Y	121,5 x 194 -	VF20.70B	121,5 x 195 -	VF20.73W	121,5 x 191,5 121,5 x 201,5	VF25.61Z	121,5 x 191,5 121,5 x 201,5
											VF20.77X	82,7 x 195
											VF20.78D	92,7 x 195 -
											VF20.79L	122,1 x 195 -

LAYER

Sp Th 2,5

H Ht 110
P Dpt 197
207
L W 90
100
129,4

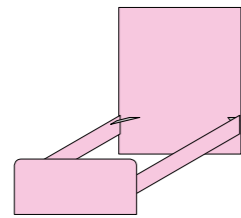

H Ht 110
P Dpt 200
-
L W 90
100
129,4

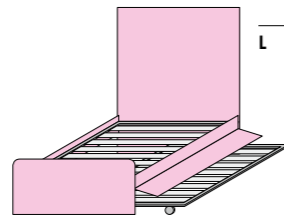

H Ht 110
P Dpt 200
-
L W 90
100
129,4

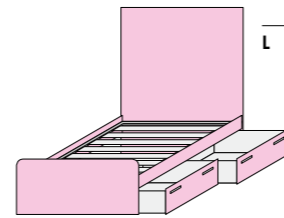

H Ht 110
P Dpt 202
-
L W 100
129,4

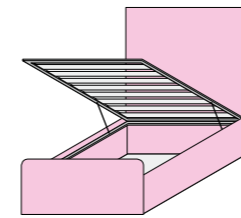

H Ht 110
P Dpt 199,5
209,5
L W 90
100
129,4

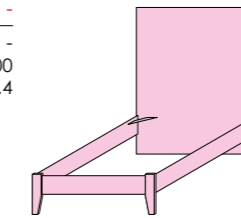

H Ht 110
P Dpt 199
209
L W 90,7
100,7
130,1

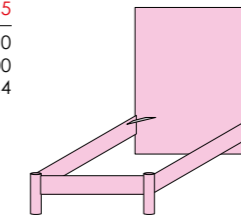

H Ht 110
P Dpt 199,3
-
L W 90
100
129,4

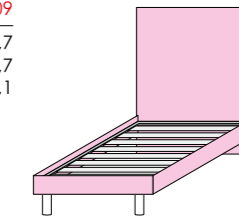

rete L bed base W	COD.	interno letto internal dimensions	COD.	interno letto internal dimensions	COD.	interno letto internal dimensions	COD.	interno letto internal dimensions	COD.	interno letto internal dimensions	COD.	interno letto internal dimensions
80 x 190	VF23.26B	81,5 x 191	VF23.29W	81,5 x 194	VF23.32F	81,5 x 194	-	-	VF23.37P	81,5 x 191,5	VF23.40Y	81,5 x 191,5
90 x 190 200	VF23.27H	91,5 x 191 91,5 x 201	VF23.30T	91,5 x 194 -	VF23.33N	91,5 x 194 -	VF23.35A	91,5 x 195 -	VF23.38V	91,5 x 191,5 91,5 x 201,5	VF23.41E	91,5 x 191,5 91,5 x 201,5
120 x 190 200	VF23.28Q	121,5 x 191 121,5 x 201	VF23.31Z	121,5 x 194 -	VF23.34U	121,5 x 194 -	VF23.36G	121,5 x 195 -	VF23.39B	121,5 x 191,5 121,5 x 201,5	VF23.42M	121,5 x 191,5 121,5 x 201,5
											VF23.43T	82,7 x 195
											VF23.44Z	92,7 x 195 -
											VF23.45F	122,1 x 195 -

PILL

Sp Th 5

La testata può essere bicolore
Headboard can be two-colored

Specificare Sx o Dx (disegni Sx)
Specify L or R (drawings L)

H Ht 116,3
P Dpt 199,5
209,5
L W 107
117
146,4

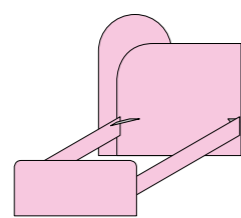

H Ht 116,3
P Dpt 202,5
-
L W 107
117
146,4

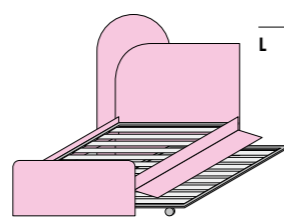

H Ht 116,3
P Dpt 202,5
-
L W 107
117
146,4

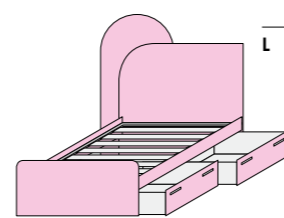

H Ht 116,3
P Dpt 204,5
-
L W 117
146,4

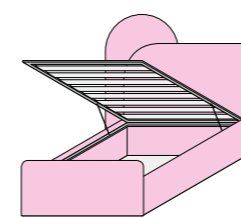

H Ht 116,3
P Dpt 202
212
L W 107
117
146,4

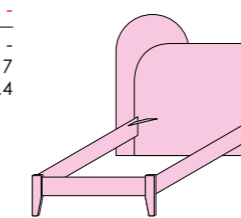

H Ht 116,3
P Dpt 201,5
211,5
L W 107
117
146,4

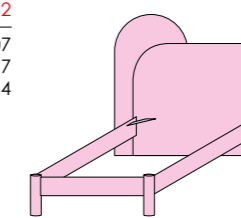

H Ht 116,3
P Dpt 201,8
-
L W 107
117
146,4

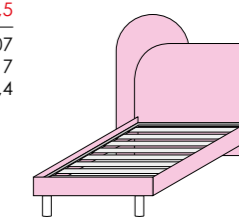

rete L bed base W	COD.	interno letto internal dimensions	COD.	interno letto internal dimensions	COD.	interno letto internal dimensions	COD.	interno letto internal dimensions	COD.	interno letto internal dimensions	COD.	interno letto internal dimensions
80 x 190	VF23.46N	81,5 x 191	VF23.49G	81,5 x 194	VF23.52S	81,5 x 194	-	-	VF23.57Z	81,5 x 191,5	VF23.60K	81,5 x 191,5
90 x 190 200	VF23.47U	91,5 x 191 91,5 x 201	VF23.50D	91,5 x 194 -	VF23.53Y	91,5 x 194 -	VF23.55M	91,5 x 195 -	VF23.58F	91,5 x 191,5 91,5 x 201,5	VF23.61R	91,5 x 191,5 91,5 x 201,5
120 x 190 200	VF23.48A	121,5 x 191 121,5 x 201	VF23.51L	121,5 x 194 -	VF23.54E	121,5 x 194 -	VF23.56T	121,5 x 195 -	VF23.59N	121,5 x 191,5 121,5 x 201,5	VF23.62X	121,5 x 191,5 121,5 x 201,5
											VF23.63D	82,7 x 195
											VF23.64L	92,7 x 195 -
											VF23.65S	122,1 x 195 -

In fase d'ordine specificare per rete P 190 o 200.
When ordering, specify for bed base Dpt 190 or 200.

pag. 42
pag. 149
pag. 150

Posizionamento pomelli e maniglie
Knobs and handles position
Accessori per letti
Beds accessories
Reti, materassi e guanciali
Bed bases, mattresses and pillows



Con testata e pediera
With headboard and footboard

Con due reti
With two bed bases

Con rete e cassettoni
With bed base and big drawers

Con rete rialzabile
With lifting base

Con giroletto legno
With wooden bed frame

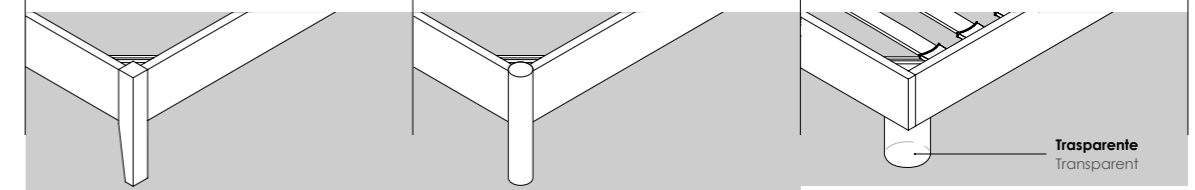

SERVER

Sp Th 2,5

H Ht 87,4
P Dpt 197
207
L W 98
108
137,4

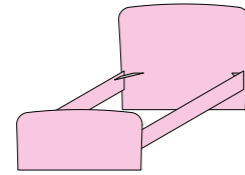

H Ht 87,4
P Dpt 200
-
L W 98
108
137,4

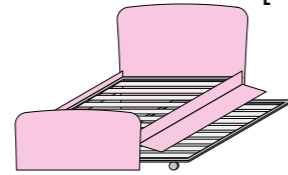

H Ht 87,4
P Dpt 200
-
L W 98
108
137,4

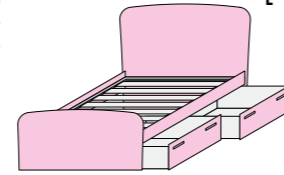

H Ht 87,4
P Dpt 202
-
L W 108
137,4

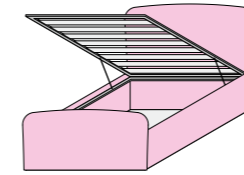

H Ht 87,4
P Dpt 199,5
209,5
L W 98
108
137,4

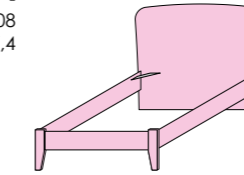

H Ht 87,4
P Dpt 199
209
L W 98
108
137,4

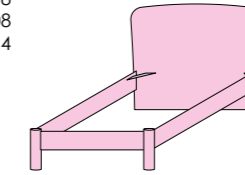

H Ht 87,4
P Dpt 199
209
L W 98
108
137,4

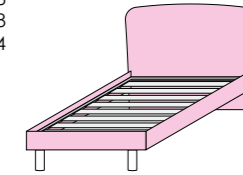

H Ht 87,4
P Dpt 199,3
-
L W 98
108
137,4

rete L bed base W	COD.	interno letto internal dimensions	COD.	interno letto internal dimensions	COD.	interno letto internal dimensions	COD.	interno letto internal dimensions	COD.	interno letto internal dimensions	COD.	interno letto internal dimensions	COD.	interno letto internal dimensions
80 x 190 (A, B)	VF20.80G	81,5 x 191	VF20.83B	81,5 x 194	VF20.86W	81,5 x 194	-	-	VF20.91U	81,5 x 191,5	VF25.62F	81,5 x 191,5	VF20.97H	82,7 x 195
90 x 190 (A, B)	VF20.81P	91,5 x 191 91,5 x 201	VF20.84H	91,5 x 194 -	VF20.87C	91,5 x 194 -	VF20.89R	91,5 x 195 -	VF20.92A	91,5 x 191,5 91,5 x 201,5	VF25.63N	91,5 x 191,5 91,5 x 201,5	VF20.98Q	92,7 x 195 -
120 x 190 (A, B)	VF20.82V	121,5 x 191 121,5 x 201	VF20.85Q	121,5 x 194 -	VF20.88K	121,5 x 194 -	VF20.90N	121,5 x 195 -	VF20.93G	121,5 x 191,5 121,5 x 201,5	VF25.64U	121,5 x 191,5 121,5 x 201,5	VF20.99W	122,1 x 195 -

SOY

Sp Th 2,5

H Ht 105,3
P Dpt 197
207
L W 110
120
149,4

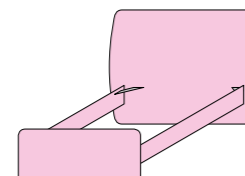

H Ht 105,3
P Dpt 200
-
L W 110
120
149,4

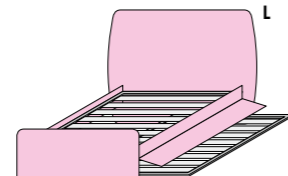

H Ht 105,3
P Dpt 200
-
L W 110
120
149,4

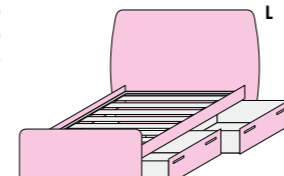

H Ht 105,3
P Dpt 202
-
L W 120
149,4

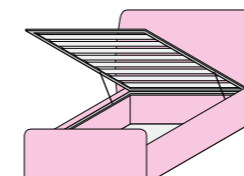

H Ht 105,3
P Dpt 199,5
209,5
L W 110
120
149,4

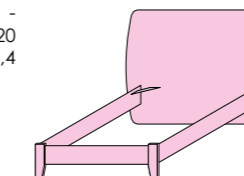

H Ht 105,3
P Dpt 199
209
L W 110
120
149,4

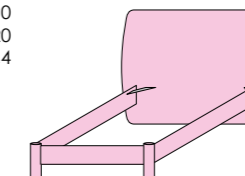

H Ht 105,3
P Dpt 199
209
L W 110
120
149,4

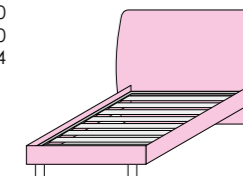

H Ht 105,3
P Dpt 199,3
-
L W 110
120
149,4

rete L bed base W	COD.	interno letto internal dimensions	COD.	interno letto internal dimensions	COD.	interno letto internal dimensions	COD.	interno letto internal dimensions	COD.	interno letto internal dimensions	COD.	interno letto internal dimensions	COD.	interno letto internal dimensions
80 x 190 (A, B)	VF23.66Y	81,5 x 191	VF23.69T	81,5 x 194	VF23.72C	81,5 x 194	-	-	VF23.77L	81,5 x 191,5	VF23.80V	81,5 x 191,5	VF23.83Q	82,7 x 195
90 x 190 (A, B)	VF23.67E	91,5 x 191 91,5 x 201	VF23.70Q	91,5 x 194 -	VF23.73K	91,5 x 194 -	VF23.75X	91,5 x 195 -	VF23.78S	91,5 x 191,5 91,5 x 201,5	VF23.81B	91,5 x 191,5 91,5 x 201,5	VF23.84W	92,7 x 195 -
120 x 190 (A, B)	VF23.68M	121,5 x 191 121,5 x 201	VF23.71W	121,5 x 194 -	VF23.74R	121,5 x 194 -	VF23.76D	121,5 x 195 -	VF23.79Y	121,5 x 191,5 121,5 x 201,5	VF23.82H	121,5 x 191,5 121,5 x 201,5	VF23.85C	122,1 x 195 -

START

Sp Th 1,8

H Ht 31,8
P Dpt 198,6
L W 86,3
96,3
125,7

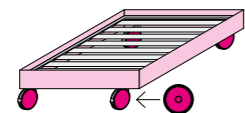

H Ht 31,8
P Dpt 198,6
L W 86,3
96,3
125,7

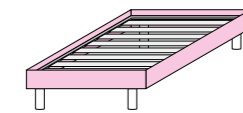

rete L bed base W	COD.	interno letto internal dimensions	COD.	interno letto internal dimensions
80 x 190 (A, B)	VF21.00T	81,5 x 191	VF21.03N	82,7 x 195
90 x 190 (A, B)	VF21.01Z	91,5 x 191	VF21.04U	92,7 x 195
120 x 190 (A, B)	VF21.02F	121,5 x 191	VF21.05A	122,1 x 195



In fase d'ordine specificare per rete P 190 o 200.
When ordering, specify for bed base Dpt 190 or 200.

pag. 42
pag. 149
pag. 150

Posizionamento pomelli e maniglie
Knobs and handles position
Accessori per letti
Beds accessories
Reti, materassi e guanciali
Bed bases, mattresses and pillows

Letti singoli

Single beds

Con testata e pediera
With headboard and footboard

Con due reti
With two bed bases

Con rete e cassettoni
With bed base and big drawers

Con rete rialzabile
With lifting base

Con giroletto legno
With wooden bed frame

NETTUNO

LIND

START

SUNRISE

Sp Th 4,3
La testata può essere bicolore
Headboard can be two-colored

Specificare Sx o Dx (disegni Sx)
Specify L or R (drawings L)

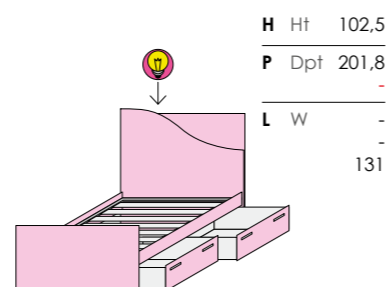
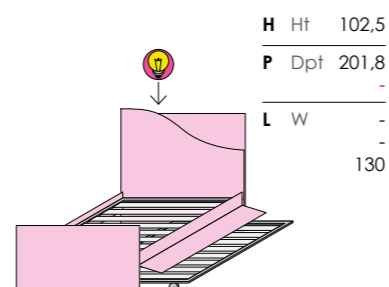
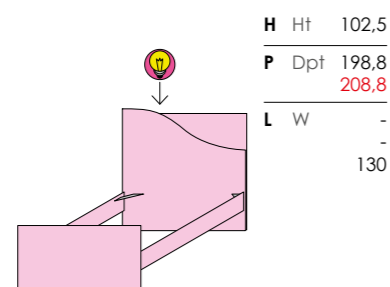

rete L bed base W	COD.	interno letto internal dimensions
80 x 190	-	-
90 x 190 200	-	-
120 x 190 200	VF21.06G	121,5 x 191 121,5 x 201

rete L bed base W	COD.	interno letto internal dimensions
80 x 190	-	-
90 x 190 200	-	-
120 x 190 200	VF21.07P	121,5 x 194 -

rete L bed base W	COD.	interno letto internal dimensions
80 x 190	-	-
90 x 190 200	-	-
120 x 190 200	VF21.08V	121,5 x 194 -

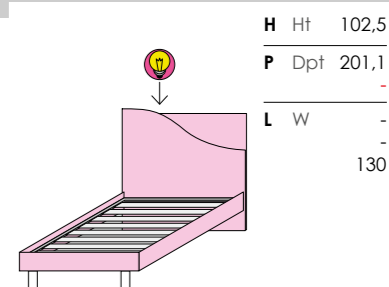
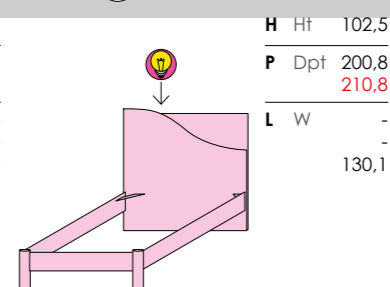
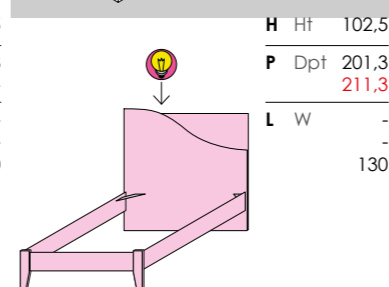
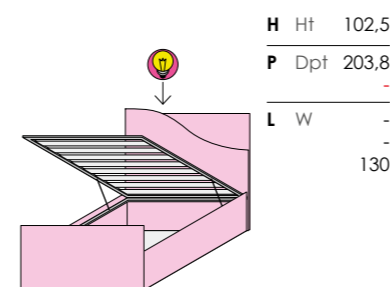

rete L bed base W	COD.	interno letto internal dimensions
80 x 190	-	-
90 x 190 200	-	-
120 x 190 200	VF21.09B	121,5 x 195 -

rete L bed base W	COD.	interno letto internal dimensions
80 x 190	-	-
90 x 190 200	-	-
120 x 190 200	VF21.10Y	121,5 x 191,5 121,5 x 201,5

rete L bed base W	COD.	interno letto internal dimensions
80 x 190	-	-
90 x 190 200	-	-
120 x 190 200	VF25.65A	121,5 x 191,5 121,5 x 201,5

rete L bed base W	COD.	interno letto internal dimensions
80 x 190	-	-
90 x 190 200	-	-
120 x 190 200	VF21.12M	122,1 x 195 -

TULIP

Sp Th 2,5
La testata può essere bicolore
Headboard can be two-colored

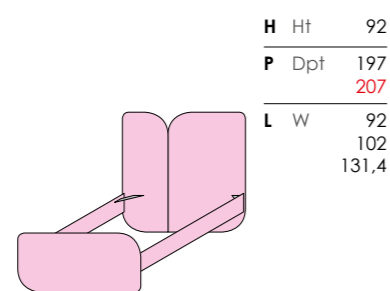

rete L bed base W	COD.	interno letto internal dimensions
80 x 190	VF21.13T	81,5 x 191
90 x 190 200	VF21.14Z	91,5 x 191 91,5 x 201
120 x 190 200	VF21.15F	121,5 x 191 121,5 x 201

rete L bed base W	COD.	interno letto internal dimensions
80 x 190	-	-
90 x 190 200	-	-
120 x 190 200	-	-

rete L bed base W	COD.	interno letto internal dimensions
80 x 190	-	-
90 x 190 200	-	-
120 x 190 200	-	-

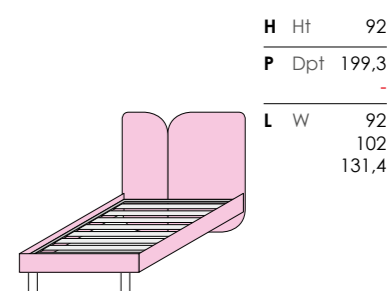
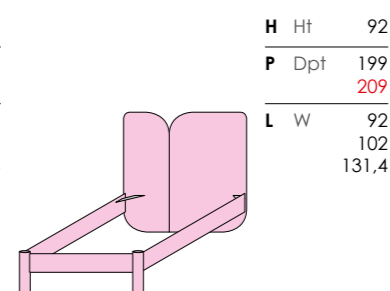
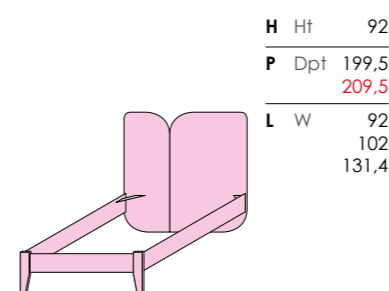

rete L bed base W	COD.	interno letto internal dimensions
80 x 190	VF21.16N	81,5 x 191,5
90 x 190 200	VF21.17U	91,5 x 191,5 91,5 x 201,5
120 x 190 200	VF21.18A	121,5 x 191,5 121,5 x 201,5

rete L bed base W	COD.	interno letto internal dimensions
80 x 190	-	-
90 x 190 200	-	-
120 x 190 200	-	-

rete L bed base W	COD.	interno letto internal dimensions
80 x 190	VF25.66G	81,5 x 191,5
90 x 190 200	VF25.67P	91,5 x 191,5 91,5 x 201,5
120 x 190 200	VF25.68V	121,5 x 191,5 121,5 x 201,5

rete L bed base W	COD.	interno letto internal dimensions
80 x 190	VF21.22S	82,7 x 195
90 x 190 200	VF21.23Y	92,7 x 195 -
120 x 190 200	VF21.24E	122,1 x 195 -

WINNER

Sp Th 2,5

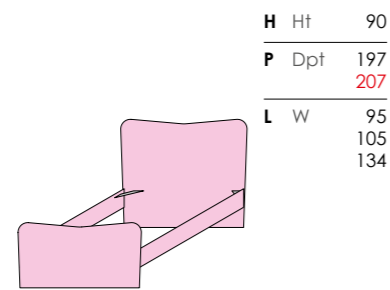

rete L bed base W	COD.	interno letto internal dimensions
80 x 190	VF21.45X	81,5 x 191
90 x 190 200	VF21.46D	91,5 x 191 91,5 x 201
120 x 190 200	VF21.47L	121,5 x 191 121,5 x 201

rete L bed base W	COD.	interno letto internal dimensions
80 x 190	-	-
90 x 190 200	-	-
120 x 190 200	-	-

rete L bed base W	COD.	interno letto internal dimensions
80 x 190	-	-
90 x 190 200	-	-
120 x 190 200	-	-

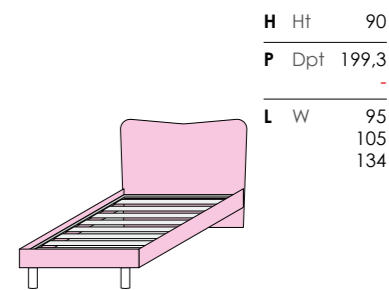
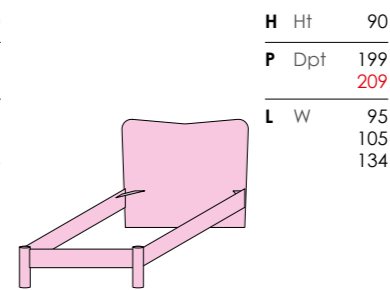
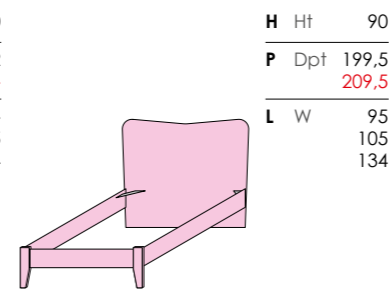
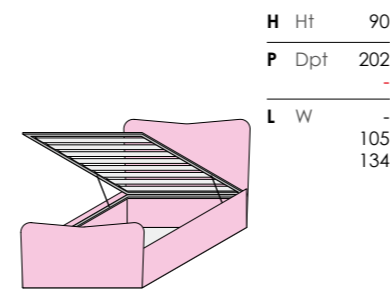

rete L bed base W	COD.	interno letto internal dimensions
80 x 190	VF21.48S	91,5 x 195 -
90 x 190 200	VF21.49Y	121,5 x 195 -

rete L bed base W	COD.	interno letto internal dimensions
80 x 190	VF21.50V	81,5 x 191,5
90 x 190 200	VF21.51B	91,5 x 191,5 91,5 x 201,5
120 x 190 200	VF21.52H	121,5 x 191,5 121,5 x 201,5

rete L bed base W	COD.	interno letto internal dimensions
80 x 190	VF25.69B	81,5 x 191,5
90 x 190 200	VF25.70Y	91,5 x 191,5 91,5 x 201,5
120 x 190 200	VF25.71E	121,5 x 191,5 121,5 x 201,5

rete L bed base W	COD.	interno letto internal dimensions
80 x 190	VF21.56K	82,7 x 195
90 x 190 200	VF21.57R	92,7 x 195 -
120 x 190 200	VF21.58X	122,1 x 195 -

In fase d'ordine specificare per rete P 190 o 200.
When ordering, specify for bed base Dpt 190 or 200.

Sovrapprezzi:
Surcharge:
per kit illuminazione led (fascia led L 120, 1 interruttore, cablaggi)
for led lighting kit (led strip W 120, 1 switch, wiring)

pag. 42
pag. 149
pag. 150

Posizionamento pomelli e maniglie
Knobs and handles position
Accessori per letti
Beds accessories
Reti, materassi e guanciali
Bed bases, mattresses and pillows

Letti singoli imbottiti

Padded single beds

Con rete fissa
With fixed base

Con rete rialzabile
With lifting base

Vano contenitore:
H 20 - P 195 - L 92/122
Space inside container:
Ht 20 - Dpt 195 - W 92/122

GALAXY

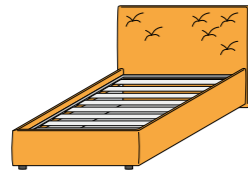

H Ht 109
P Dpt 208
215
L W 109
139

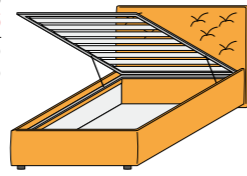

H Ht 109
P Dpt 208
215
L W 109
139

rete L bed base W		COD.	interno letto internal dimensions	COD.	interno letto internal dimensions
90 x	190 200	VF21.60A	92 x 195 92 x 202	VF21.62P	90 x 190 90 x 200
120 x	190 200	VF21.61G	122 x 195 122 x 202	VF21.63V	120 x 190 120 x 200

GALLERY

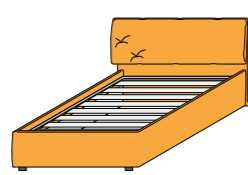

H Ht 95
P Dpt 202
209
L W 106
136

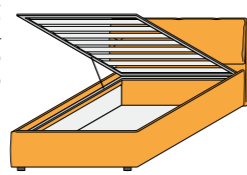

H Ht 95
P Dpt 202
209
L W 106
136

rete L bed base W		COD.	interno letto internal dimensions	COD.	interno letto internal dimensions
90 x	190 200	VF21.64B	92 x 195 92 x 202	VF21.66Q	90 x 190 90 x 200
120 x	190 200	VF21.65H	122 x 195 122 x 202	VF21.67W	120 x 190 120 x 200

KANT

Sfoderabili
Removable covers

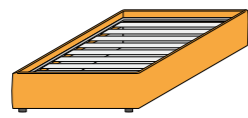

H Ht 37
P Dpt 201
208
L W 98
128

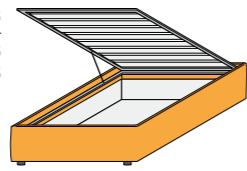

H Ht 37
P Dpt 201
208
L W 98
128

rete L bed base W		COD.	interno letto internal dimensions	COD.	interno letto internal dimensions
90 x	190 200	VF21.68C	92 x 195 92 x 202	VF21.70F	90 x 190 90 x 200
120 x	190 200	VF21.69K	122 x 195 122 x 202	VF21.71N	120 x 190 120 x 200

Tessuto ECOCHIC
ECOCHIC fabric
Similpelle ECOCHIC
ECOCHIC faux leather

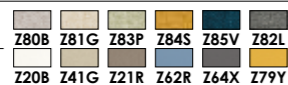

In fase d'ordine specificare per rete P 190 o 200.
When ordering, specify for bed base Dpt 190 or 200.

Con rete fissa
With fixed base

Con rete rialzabile
With lifting base

Vano contenitore:
H 20 - P 195 - L 92/122
Space inside container:
Ht 20 - Dpt 195 - W 92/122

KISS

Letti con cuciture a contrasto
(vedi tabella riepilogativa a inizio listino).
Beds with contrasting seams
(see the summary table at the top of the price list).

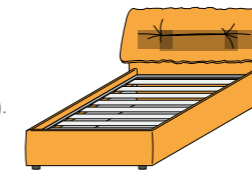

H Ht 107
P Dpt 208
215
L W 108
138

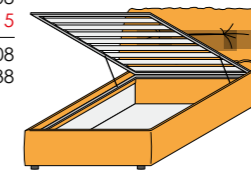

H Ht 107
P Dpt 208
215
L W 108
138

rete L bed base W		COD.	interno letto internal dimensions	COD.	interno letto internal dimensions
90 x	190 200	VF22.71S	92 x 195 92 x 202	VF22.73E	90 x 190 90 x 200
120 x	190 200	VF22.72Y	122 x 195 122 x 202	VF22.74M	120 x 190 120 x 200

RAPSODY

Le testate del letto prevedono:
versione L 90 - 2 cuciture verticali equidistanti,
versione L 120 - 3 cuciture verticali equidistanti.
The headboards of the bed include:
W 90 version - 2 equidistant vertical seams,
W 120 version - 3 equidistant vertical seams.

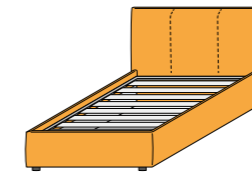

H Ht 109
P Dpt 208
215
L W 109
139

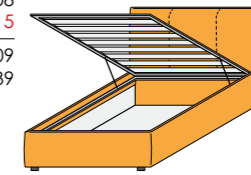

H Ht 109
P Dpt 208
215
L W 109
139

rete L bed base W		COD.	interno letto internal dimensions	COD.	interno letto internal dimensions
90 x	190 200	VF21.72U	92 x 195 92 x 202	VF21.74G	90 x 190 90 x 200
120 x	190 200	VF21.73A	1110,00 122 x 202	VF21.75P	120 x 190 120 x 200

TWIN

Sfoderabili
Removable covers

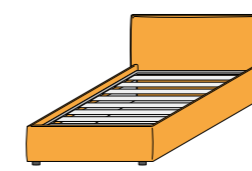

H Ht 98
P Dpt 206
213
L W 109
139

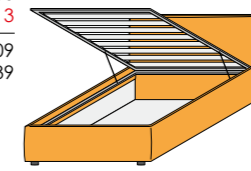

H Ht 98
P Dpt 206
213
L W 109
139

rete L bed base W		COD.	interno letto internal dimensions	COD.	interno letto internal dimensions
90 x	190 200	VF21.76V	92 x 195 92 x 202	VF21.78H	90 x 190 90 x 200
120 x	190 200	VF21.77B	122 x 195 122 x 202	VF21.79Q	120 x 190 120 x 200

Con testata e pediera
With headboard and footboard

Con due reti
With two bed bases

Con rete e cassettoni
With bed base and big drawers

Con rete rialzabile
With lifting base

Vano contenitore:
H 19,5 - P 195 - L 83
Space inside container:
Ht 19,5 - Dpt 195 - W 83

Per rete estraibile materasso L 80 H 17 max.
Mattress W 80 Ht 17 cm max for pull-out bed base.

BANNER

Sp Th 1,8

H Ht 45
P Dpt 195,6
L W 91

H Ht 45
P Dpt 198,6
L W 91

H Ht 45
P Dpt 198,6
L W 91

H Ht 45
P Dpt 198,6
L W 91

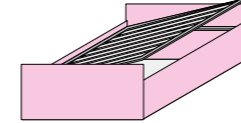
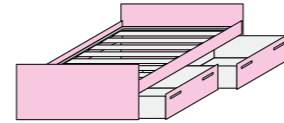
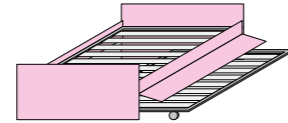
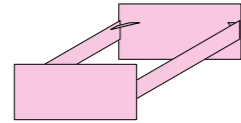

rete L bed base W	COD.	interno letto internal dimensions	COD.	interno letto internal dimensions	COD.	interno letto internal dimensions	COD.	interno letto internal dimensions
80	VF21.80M	81,5 x 191	VF21.81T	81,5 x 194	VF21.82Z	81,5 x 194	VF21.83F	81,5 x 194

FOLDER

Sp Th 2,5

H Ht 55,3
P Dpt 197
L W 91

H Ht 55,3
P Dpt 200
L W 91

H Ht 55,3
P Dpt 200
L W 91

H Ht 55,3
P Dpt 200
L W 91

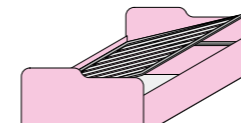
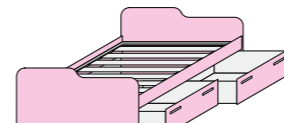
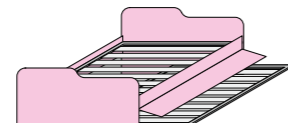
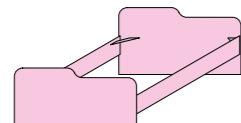

rete L bed base W	COD.	interno letto internal dimensions	COD.	interno letto internal dimensions	COD.	interno letto internal dimensions	COD.	interno letto internal dimensions
80	VF21.84N	81,5 x 191	VF21.85U	81,5 x 194	VF21.86A	81,5 x 194	VF21.87G	81,5 x 194

SERVER

Sp Th 2,5

H Ht 50
P Dpt 197
L W 93,9

H Ht 50
P Dpt 200
L W 93,9

H Ht 50
P Dpt 200
L W 93,9

H Ht 50
P Dpt 200
L W 93,9

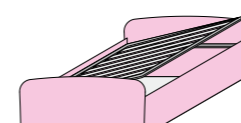
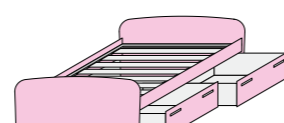
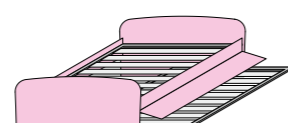
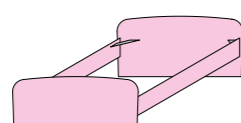

rete L bed base W	COD.	interno letto internal dimensions	COD.	interno letto internal dimensions	COD.	interno letto internal dimensions	COD.	interno letto internal dimensions
80	VF21.88P	81,5 x 191	VF21.89V	81,5 x 194	VF21.90S	81,5 x 194	VF21.91Y	81,5 x 194

Divani letto

Sofa beds

Con testata e pediera
With headboard and footboard

Con due reti
With two bed bases

Con rete e cassettoni
With bed base and big drawers

Per rete estraibile materasso L 80 H 12 max.
Mattress W 80 Ht 12 cm max for pull-out bed base.

FOLDER

Sp Th 2,5

H Ht 55,5
P Dpt 200
L W 91

H Ht 55,5
P Dpt 200
L W 91

H Ht 55,5
P Dpt 200
L W 91

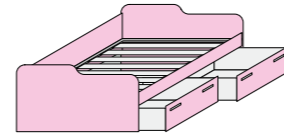
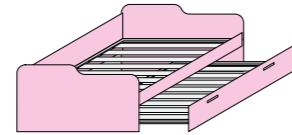
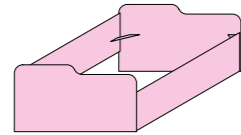

rete L bed base W	COD.	interno letto internal dimensions	COD.	interno letto internal dimensions	COD.	interno letto internal dimensions
80	VF21.97N	81,5 x 194	VF21.98U	81,5 x 194	VF21.99A	81,5 x 194

WINNER

Sp Th 2,5

H Ht 70,5
P Dpt 200
L W 93

H Ht 70,5
P Dpt 200
L W 93

H Ht 70,5
P Dpt 200
L W 93

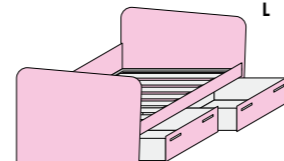
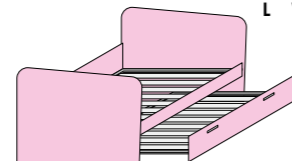
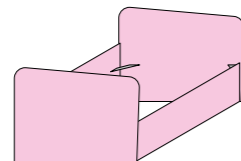

rete L bed base W	COD.	interno letto internal dimensions	COD.	interno letto internal dimensions	COD.	interno letto internal dimensions
80	VF22.01D	81,5 x 194	VF22.02L	81,5 x 194	VF22.03S	81,5 x 194

Coppia poggiaschiena in spugna
Pair of foam back cushions

L W 197
P Dpt 33
H Ht 35

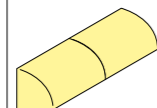

COD. VF33.87U

L W 198
P Dpt 33,5
H Ht 36

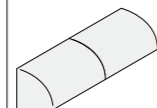

COD. VF33.88A

grezzo
raw

Fodera per poggiaschiena
Back cushions clothing cover

per coppia poggiaschiena in spugna
for pair of foam back cushions

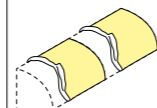

COD. VF33.89G

Materasso in spugna
Foam mattress

L W 81,5
P Dpt 189
H Ht 12



COD. VF33.24S

con elastici
Bedsread with elastic

per materassi H 12 e H 17
for mattress Ht 12 and Ht 17

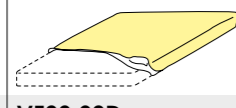

COD. VF33.90D

Cotton fabric
H Ht 140



COD. VF33.91L

Giroletti metallici

Metal bed frames

Con 4 ruote piroettanti con freno
With 4 turning wheels with brake

Con 4 piedi cilindrici trasparenti
With 4 transparent cylindrical feet

H Ht 29

H Ht 29

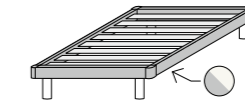
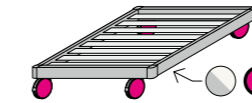

rete L bed base W	COD.	interno letto internal dimensions	COD.	interno letto internal dimensions
88 x 193	VF33.69W	84 x 189	VF33.70T	84 x 189
98 x 193	VF33.82M	94 x 189	VF33.84Z	94 x 189
127,4 x 193	VF33.83T	124 x 189	VF33.85F	124 x 189

Accessori
Accessories

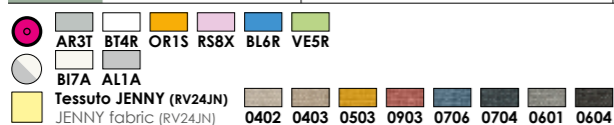

pag. 42
pag. 150

Posizionamento pomelli e maniglie
Knobs and handles position
Reti, materassi e guanciali
Bed bases, mattresses and pillows



Con testata e pediera
With headboard and footboard

Con rete rialzabile
With lifting base

Con giroletto legno
With wooden bed frame
NETTUNO

LIND

BANNER

Sp Th 1,8

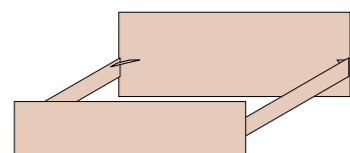

H Ht 90
P Dpt 195,6
205,6
L W 170

rete L bed base W	COD.	interno letto internal dimensions
190 (A)	VF19.75V	161,5 x 191
160 x (B)		
200 (A)		161,5 x 201
(B)		

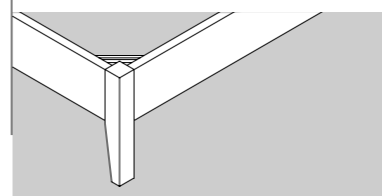

H Ht 90
P Dpt 198,8
208,8
L W 170

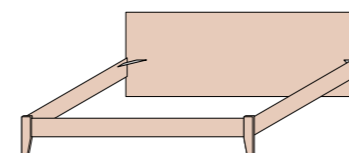

COD.	interno letto internal dimensions
VF19.76B	161,5 x 191,5
	161,5 x 201,5

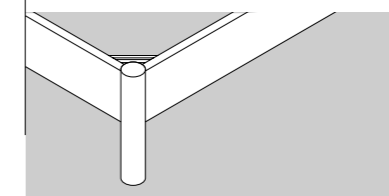

H Ht 90
P Dpt 198,3
208,3
L W 170,7

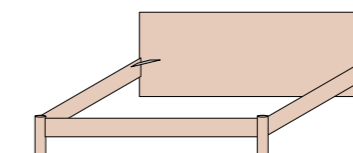

COD.	interno letto internal dimensions
VF25.72M	161,5 x 191,5
	161,5 x 201,5

BENT

Sp Th 2,5

La testata può essere bicolore
Headboard can be two-colored

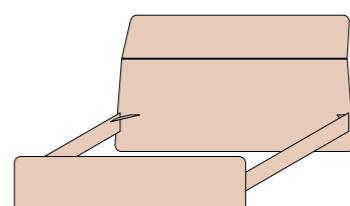

H Ht 105,6
P Dpt 203,2
213,2
L W 180

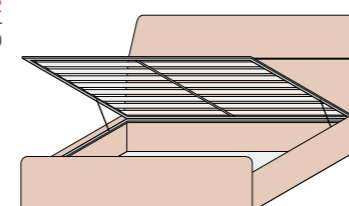

H Ht 105,6
P Dpt 208,2
218,2
L W 180

rete L bed base W	COD.	interno letto internal dimensions
190 (A)	VF19.77H	161,5 x 191
160 x (B)		
200 (A)		161,5 x 201
(B)		

COD.	interno letto internal dimensions
VF19.78Q	161,5 x 195
	161,5 x 205

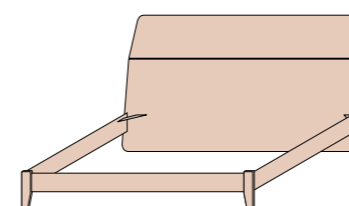

H Ht 105,6
P Dpt 205,7
215,7
L W 180

COD.	interno letto internal dimensions
VF19.79W	161,5 x 191,5
	161,5 x 201,5

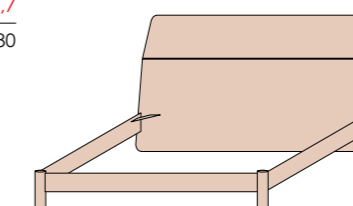

H Ht 105,6
P Dpt 205,2
215,2
L W 180

COD.	interno letto internal dimensions
VF25.73T	161,5 x 191,5
	161,5 x 201,5

EDGE

Sp Th 2,5

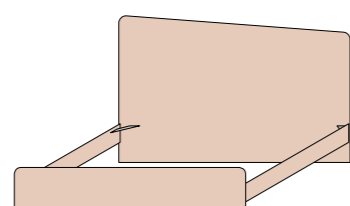

H Ht 120
P Dpt 197
207
L W 170

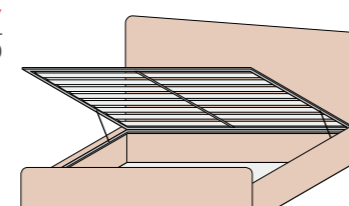

H Ht 120
P Dpt 202
212
L W 170

rete L bed base W	COD.	interno letto internal dimensions
190 (A)	VF19.80T	161,5 x 191
160 x (B)		
200 (A)		161,5 x 201
(B)		

COD.	interno letto internal dimensions
VF19.81Z	161,5 x 195
	161,5 x 205

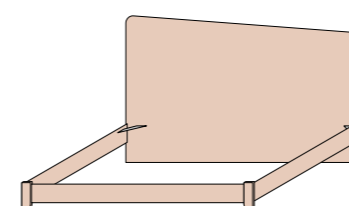

H Ht 120
P Dpt 199,5
209,5
L W 170

COD.	interno letto internal dimensions
VF19.82F	161,5 x 191,5
	161,5 x 201,5

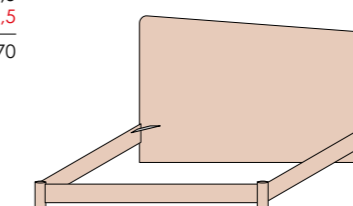

H Ht 120
P Dpt 199
209
L W 170,7

COD.	interno letto internal dimensions
VF25.74Z	161,5 x 191,5
	161,5 x 201,5

In fase d'ordine specificare per rete P 190 o 200.
When ordering, specify for bed base Dpt 190 or 200.

pag. 149
pag. 150

Accessori per letti
Beds accessories
Reti, materassi e guanciali
Bed bases, mattresses and pillows



Con testata e pediera
With headboard and footboard

Con rete rialzabile
With lifting base

Con giroletto legno
With wooden bed frame
NETTUNO

LIND

EDGE PLUS

Sp Th 2,5
Mensole L 30 P 26
Shelves W 30 Dpt 26

Specificare Sx o Dx (disegni Sx)
Specify L or R (drawings L)

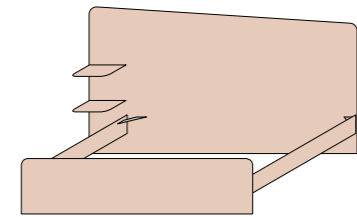

H Ht 120
P Dpt 197
207
L W 200

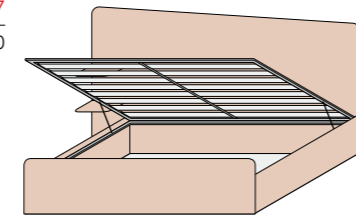

H Ht 120
P Dpt 202
212
L W 200

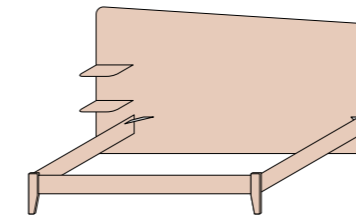

H Ht 120
P Dpt 199,5
209,5
L W 200

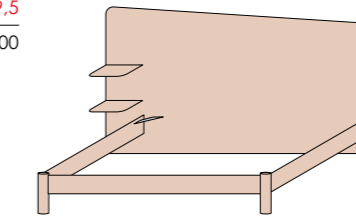

H Ht 120
P Dpt 199
209
L W 200

rete L bed base W	COD.	interno letto internal dimensions	COD.	interno letto internal dimensions	COD.	interno letto internal dimensions	COD.	interno letto internal dimensions
190 (A)	VF19.83N	161,5 x 191	VF19.84U	161,5 x 195	VF19.85A	161,5 x 191,5	VF25.75F	161,5 x 191,5
160 x (B)		161,5 x 201		161,5 x 205		161,5 x 201,5		161,5 x 201,5
200 (A)								
(B)								

FOLDER

Sp Th 2,5

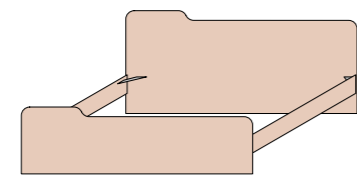

H Ht 98
P Dpt 197
207
L W 171

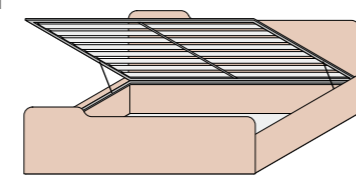

H Ht 98
P Dpt 202
212
L W 171

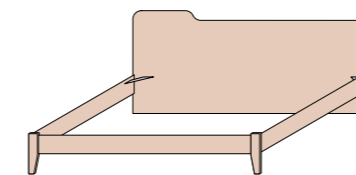

H Ht 98
P Dpt 199,5
209,5
L W 171

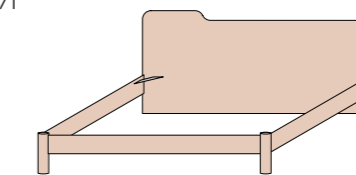

H Ht 98
P Dpt 199
209
L W 171

rete L bed base W	COD.	interno letto internal dimensions	COD.	interno letto internal dimensions	COD.	interno letto internal dimensions	COD.	interno letto internal dimensions
190 (A)	VF19.86G	161,5 x 191	VF19.87P	161,5 x 195	VF19.88V	161,5 x 191,5	VF25.76N	161,5 x 191,5
160 x (B)		161,5 x 201		161,5 x 205		161,5 x 201,5		161,5 x 201,5
200 (A)								
(B)								

LAYER

Sp Th 2,5

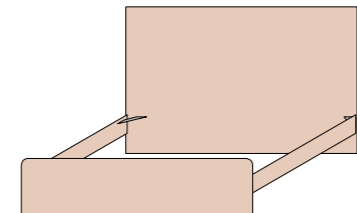

H Ht 110
P Dpt 197
207
L W 170

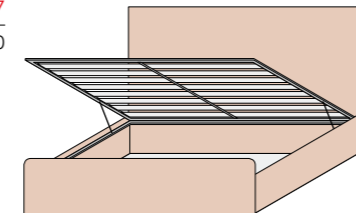

H Ht 110
P Dpt 202
212
L W 170

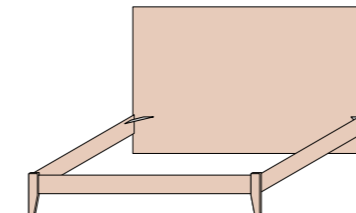

H Ht 110
P Dpt 199,5
209,5
L W 170

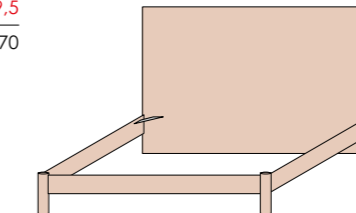

H Ht 110
P Dpt 199
209
L W 170,7

rete L bed base W	COD.	interno letto internal dimensions	COD.	interno letto internal dimensions	COD.	interno letto internal dimensions	COD.	interno letto internal dimensions
190 (A)	VF23.86K	161,5 x 191	VF23.87R	161,5 x 195	VF23.88X	161,5 x 191,5	VF23.89D	161,5 x 191,5
160 x (B)		161,5 x 201		161,5 x 205		161,5 x 201,5		161,5 x 201,5
200 (A)								
(B)								

In fase d'ordine specificare per rete P 190 o 200.
When ordering, specify for bed base Dpt 190 or 200.

pag. 149
pag. 150

Accessori per letti
Beds accessories
Reti, materassi e guanciali
Bed bases, mattresses and pillows



Con testata e pediera
With headboard and footboard

Con rete rialzabile
With lifting base

Con giroletto legno
With wooden bed frame
NETTUNO

LIND

PILL

Sp Th 2,5
La testata può essere bicolore
Headboard can be two-colored

Specificare Sx o Dx (disegni Sx)
Specify L or R (drawings L)

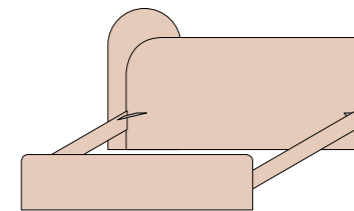

H Ht 116,3
P Dpt 199,5
209,5
L W 187

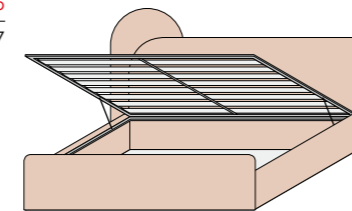

H Ht 116,3
P Dpt 204,5
214,5
L W 187

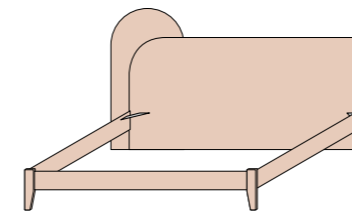

H Ht 116,3
P Dpt 202
212
L W 187

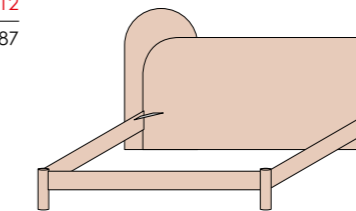

H Ht 116,3
P Dpt 199
209
L W 187

rete L bed base W	COD.	interno letto internal dimensions	COD.	interno letto internal dimensions	COD.	interno letto internal dimensions	COD.	interno letto internal dimensions
190 (A)	VF23.90A	161,5 x 191	998,00	161,5 x 195	417,00	161,5 x 191,5	439,00	161,5 x 191,5
160 x (B)		494,00	1110,00	495,00	519,00	519,00	519,00	
(A)		399,00	1097,00	417,00	439,00	439,00	439,00	
200 (B)		494,00	1204,00	495,00	519,00	519,00	519,00	

SERVER

Sp Th 2,5

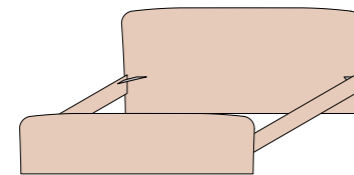

H Ht 88
P Dpt 197
207
L W 178

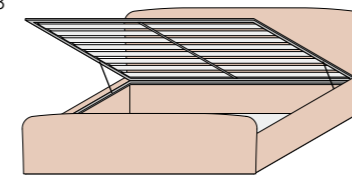

H Ht 88
P Dpt 202
212
L W 178

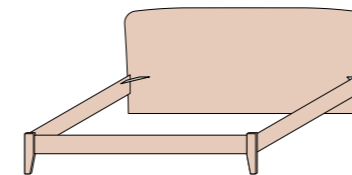

H Ht 88
P Dpt 199,5
209,5
L W 178

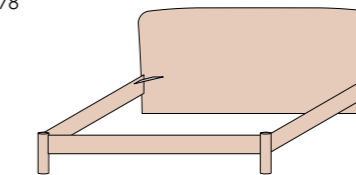

H Ht 88
P Dpt 199
209
L W 178

rete L bed base W	COD.	interno letto internal dimensions	COD.	interno letto internal dimensions	COD.	interno letto internal dimensions	COD.	interno letto internal dimensions
190 (A)	VF19.89B	161,5 x 191	937,00	161,5 x 195	357,00	161,5 x 191,5	379,00	161,5 x 191,5
160 x (B)		390,00	1028,00	419,00	443,00	443,00	443,00	
(A)		317,00	1035,00	357,00	379,00	379,00	379,00	
200 (B)		390,00	1122,00	419,00	443,00	443,00	443,00	

SOY

Sp Th 2,5

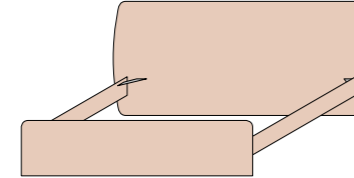

H Ht 105,3
P Dpt 197
207
L W 190

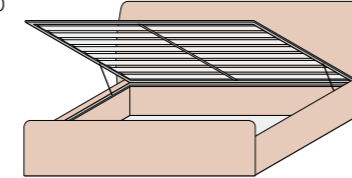

H Ht 105,3
P Dpt 202
212
L W 190

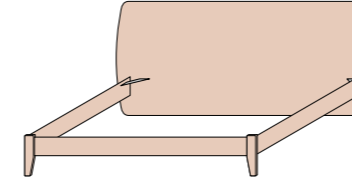

H Ht 105,3
P Dpt 199,5
209,5
L W 190

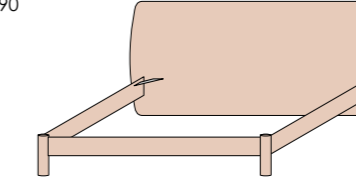

H Ht 105,3
P Dpt 199
209
L W 190

rete L bed base W	COD.	interno letto internal dimensions	COD.	interno letto internal dimensions	COD.	interno letto internal dimensions	COD.	interno letto internal dimensions
190 (A)	VF23.94B	161,5 x 191	982,00	161,5 x 195	400,00	161,5 x 191,5	423,00	161,5 x 191,5
160 x (B)		474,00	1090,00	475,00	499,00	499,00	499,00	
(A)		383,00	1080,00	400,00	423,00	423,00	423,00	
200 (B)		474,00	1184,00	475,00	499,00	499,00	499,00	

In fase d'ordine specificare per rete P 190 o 200.
When ordering, specify for bed base Dpt 190 or 200.

pag. 149
pag. 150

Accessori per letti
Beds accessories
Reti, materassi e guanciali
Bed bases, mattresses and pillows

Letti matrimoniali

Double beds

Con testata e pediera
With headboard and footboard

Con rete rialzabile
With lifting base

Con giroletto legno
With wooden bed frame
NETTUNO

LIND

SUNRISE

Sp Th 4,3

La testata può essere bicolore
Headboard can be two-colored

Specificare Sx o Dx (disegni Sx)
Specify L or R (drawings L)

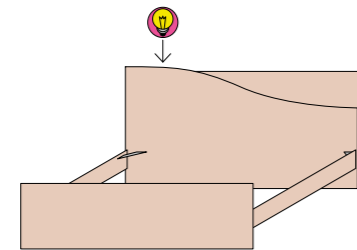

H Ht 102,5
P Dpt 198,8
208,8
L W 170

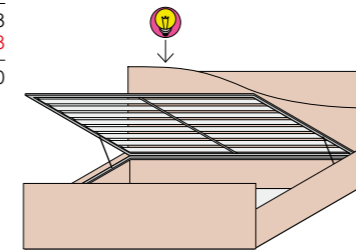

H Ht 102,5
P Dpt 203,8
213,8
L W 170

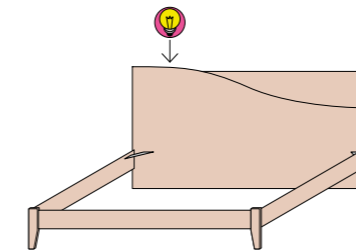

H Ht 102,5
P Dpt 201,3
211,3
L W 170

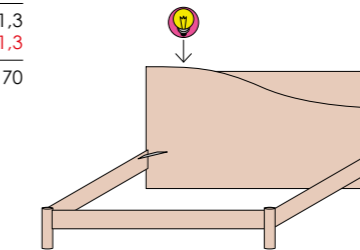

H Ht 102,5
P Dpt 200,8
210,8
L W 170,7

rete L bed base W	COD.	interno letto internal dimensions	COD.	interno letto internal dimensions	COD.	interno letto internal dimensions	COD.	interno letto internal dimensions
190 (A)	VF19.92M	161,5 x 191	VF19.93T	161,5 x 195	VF19.94Z	161,5 x 191,5	VF25.78A	161,5 x 191,5
160 x (B)		161,5 x 201		161,5 x 205		161,5 x 201,5		161,5 x 201,5
200 (A)								
(B)								

TULIP

Sp Th 2,5

La testata può essere bicolore
Headboard can be two-colored

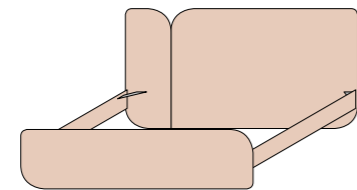

H Ht 92
P Dpt 197
207
L W 172

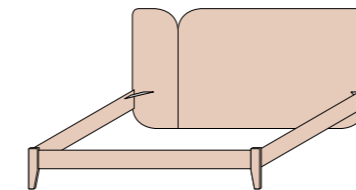

H Ht 92
P Dpt 199,5
209,5
L W 172

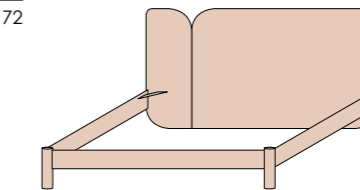

H Ht 92
P Dpt 199
209
L W 172

rete L bed base W	COD.	interno letto internal dimensions	COD.	interno letto internal dimensions	COD.	interno letto internal dimensions
190 (A)	VF19.95F	161,5 x 191	VF19.96N	161,5 x 191,5	VF25.79G	161,5 x 191,5
160 x (B)		161,5 x 201		161,5 x 201,5		161,5 x 201,5
200 (A)						
(B)						

WINNER

Sp Th 2,5

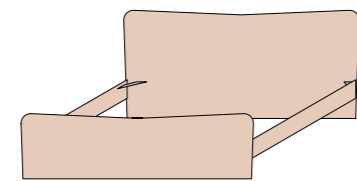

H Ht 90
P Dpt 197
207
L W 175

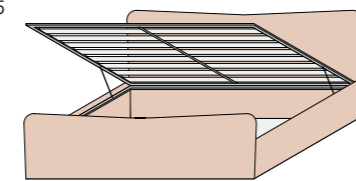

H Ht 90
P Dpt 202
212
L W 175

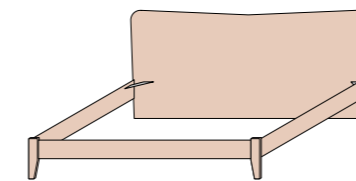

H Ht 90
P Dpt 199,5
209,5
L W 175

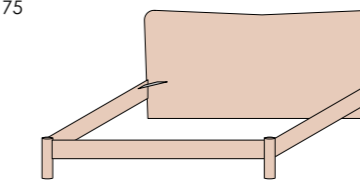

H Ht 90
P Dpt 199
209
L W 175

rete L bed base W	COD.	interno letto internal dimensions	COD.	interno letto internal dimensions	COD.	interno letto internal dimensions	COD.	interno letto internal dimensions
190 (A)	VF19.97U	161,5 x 191	VF19.98A	161,5 x 195	VF19.99G	161,5 x 191,5	VF25.80D	161,5 x 191,5
160 x (B)		161,5 x 201		161,5 x 205		161,5 x 201,5		161,5 x 201,5
200 (A)								
(B)								

In fase d'ordine specificare per rete P 190 o 200.
When ordering, specify for bed base Dpt 190 or 200.

Sovrapprezzi:
Surcharge:
+ 74,00 per kit illuminazione led (fascia led L 120, 1 interruttore, cablaggi)
for led lighting kit (led strip W 120, 1 switch, wiring)

pag. 149
pag. 150

Accessori per letti
Beds accessories
Reti, materassi e guanciali
Bed bases, mattresses and pillows

Letti matrimoniali imbottiti

Padded double beds

Con rete fissa
With fixed base

Con rete rialzabile
With lifting base

Vano contenitore:
H 20 - P 195 - L 162
Space inside container:
Ht 20 - Dpt 195 - W 162

Con rete rialzabile
With lifting base

Vano contenitore:
H 20 - P 195 - L 162
Space inside container:
Ht 20 - Dpt 195 - W 162

GALAXY

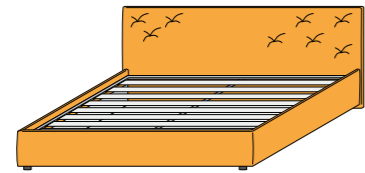

H Ht 109
P Dpt 208
215
L W 179

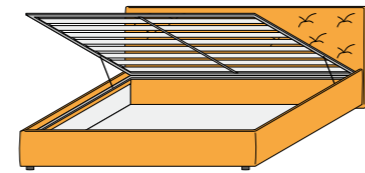

H Ht 109
P Dpt 208
215
L W 179

rete L bed base W	COD.	interno letto internal dimensions	COD.	interno letto internal dimensions
160 x 190 200	VF22.39X	162 x 195 162 x 202	VF22.40U	160 x 190 160 x 200

KISS

Letti con cuciture a contrasto
(vedi tabella riepilogativa a inizio listino).
Beds with contrasting seams
(see the summary table at the top of the price list).

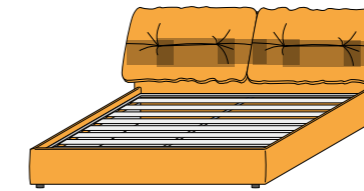

H Ht 107
P Dpt 208
215
L W 158
168
178
198
218*

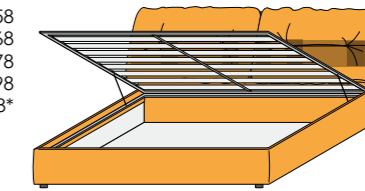

H Ht 107
P Dpt 208
215
L W 158
168
178
198
218*

* H Ht 114,5

rete L bed base W	COD.	interno letto internal dimensions	COD.	interno letto internal dimensions
140 x 200	VF22.75T	142 x 202	VF22.80R	140 x 200
150 x 200	VF22.76Z	152 x 202	VF22.81X	150 x 200
160 x 190 200	VF22.77F	162 x 195 162 x 202	VF22.82D	160 x 190 160 x 200
180 x 200	VF22.78N	182 x 202	VF22.83L	180 x 200
200 x 200	VF22.79U	202 x 202	VF22.84S	200 x 200

GALLERY

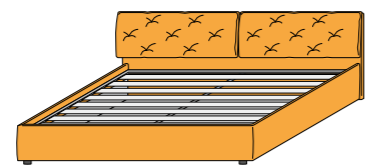

H Ht 95
P Dpt 202
209
L W 176

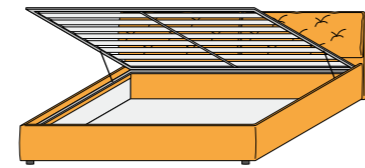

H Ht 95
P Dpt 202
209
L W 176

rete L bed base W	COD.	interno letto internal dimensions	COD.	interno letto internal dimensions
160 x 190 200	VF22.41A	162 x 195 162 x 202	VF22.42G	160 x 190 160 x 200

RAPSODY

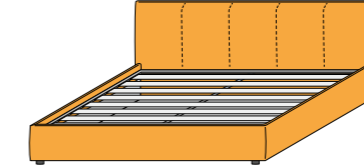

H Ht 109
P Dpt 208
215
L W 179

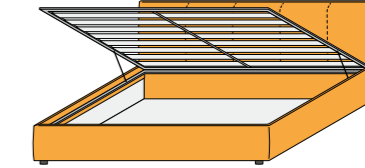

H Ht 109
P Dpt 208
215
L W 179

rete L bed base W	COD.	interno letto internal dimensions	COD.	interno letto internal dimensions
160 x 190 200	VF22.47Q	162 x 195 162 x 202	VF22.48W	160 x 190 160 x 200

KANT

Sfoderabili
Removable covers

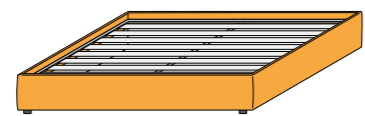

H Ht 37
P Dpt 201
208
L W 168

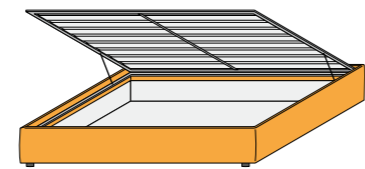

H Ht 37
P Dpt 201
208
L W 168

rete L bed base W	COD.	interno letto internal dimensions	COD.	interno letto internal dimensions
160 x 190 200	VF22.43P	162 x 195 162 x 202	VF22.44V	160 x 190 160 x 197

TWIN

Sfoderabili
Removable covers

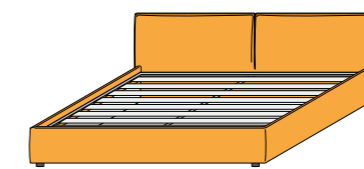

H Ht 98
P Dpt 206
213
L W 159
169
179
199
219*

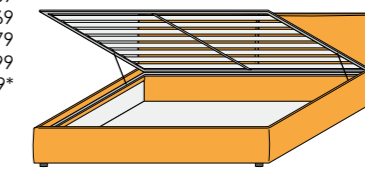

H Ht 98
P Dpt 206
213
L W 159
169
179
199
219*

* H Ht 105,5

rete L bed base W	COD.	interno letto internal dimensions	COD.	interno letto internal dimensions
140 x 200	VF22.63Z	142 x 202	VF22.67A	140 x 200
150 x 200	VF22.64F	152 x 202	VF22.68G	150 x 200
160 x 190 200	VF22.49C	162 x 195 162 x 202	VF22.50Z	160 x 190 160 x 200
180 x 200	VF22.65N	182 x 202	VF22.69P	180 x 200
200 x 200	VF22.66U	202 x 202	VF22.70L	200 x 200

Tessuto ECOCHIC
ECOCHIC fabric
Similpelle ECOCHIC
ECOCHIC faux leather

Z80B	Z81G	Z83P	Z84S	Z85V	Z82L
Z20B	Z41G	Z21R	Z62R	Z64X	Z79Y

Consegna 5 settimane circa dal ricevimento dell'ordine.
Delivery approximately 5 weeks from order receipt.

In fase d'ordine specificare per rete P 190 o 200.
When ordering, specify for bed base Dpt 190 or 200.

pag. 149
pag. 150

Accessori per letti
Beds accessories
Reti, materassi e guanciali
Bed bases, mattresses and pillows

Letti scorrevoli NEW ROLL

NEW ROLL sliding beds

Letti scorrevoli EDGE

EDGE sliding beds

Informazioni tecniche:
Technical information:

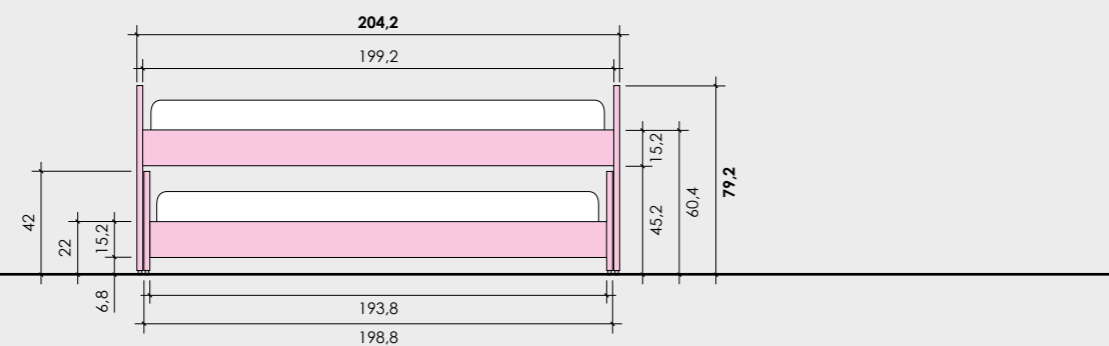

Informazioni tecniche:
Technical information:

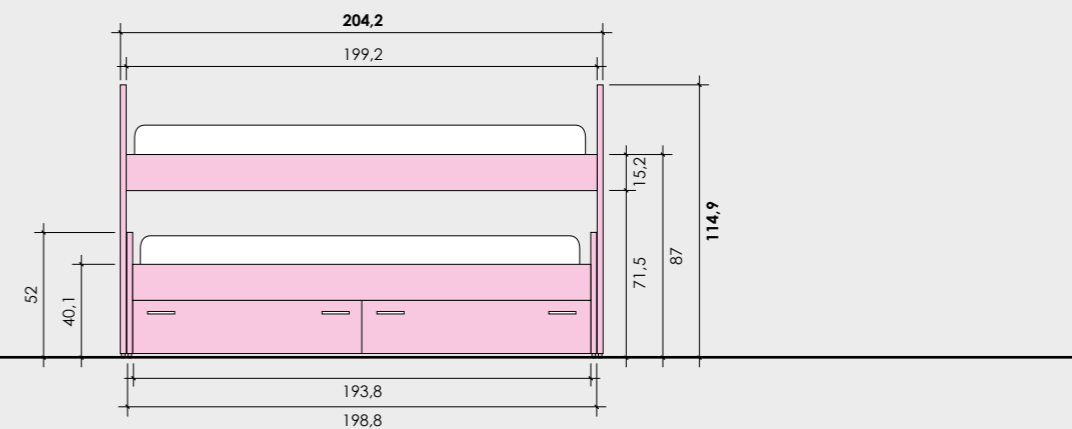

Letti scorrevoli con ruote autofrenanti.
Sliding beds with self-braking wheels.

Coppia letti
Pair of beds

H	Ht	79,2
P	Dpt	204,2
L	W	89,8

Letto superiore
Higher bed

H	Ht	79,2
P	Dpt	204,2
L	W	89,8

Letto inferiore
Lower bed

H	Ht	42
P	Dpt	198,8
L	W	89,8

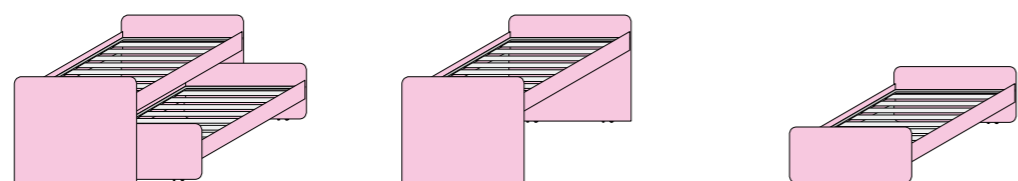

reti L bed bases W	COD.	COD.	interno letto internal dimensions	COD.	interno letto internal dimensions
80 x 190	VF22.51F	VF22.52N	198,2 x 79,9	VF22.53U	192,8 x 79,9

Letto superiore scorrevole con ruote autofrenanti.
Higher sliding bed with self-braking wheels.

H	Ht	114,9
P	Dpt	204,2
L	W	89,8

Utilizzabile anche senza rete
Can also be used without a net

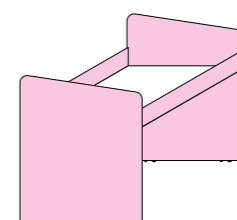

Scala in metallo SHORT
SHORT metal ladder
con fissaggio
with fixing

L	W	35
H	Ht	88

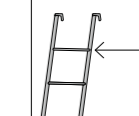

reti L bed bases W	COD.	COD.
80 x 190	VF22.58B	VF22.62T
		107,00

Letti inferiori scorrevoli con ruote autofrenanti.
Lower sliding beds with self-braking wheels.

H	Ht	52
P	Dpt	198,8
L	W	88,2

Per rete estraibile materasso
L 80 H 17 max.
Mattress W 80 Ht 17 cm max
for pull-out bed base.

H	Ht	52
P	Dpt	198,8
L	W	88,2

I cassettoni sono fissati alla
struttura tramite guide.
The big drawers are fixed to
the structure by means of
runners.

H	Ht	52
P	Dpt	198,8
L	W	88,2

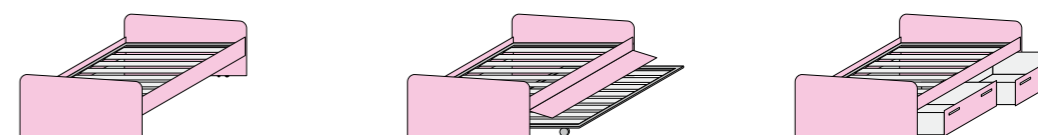

reti L bed bases W	COD.	interno letto internal dimensions	COD.	interno letto internal dimensions	COD.	interno letto internal dimensions
80 x 190	VF22.59H	198,2 x 79,9	VF22.60E	198,2 x 79,9	VF22.61M	192,8 x 79,9

Protezioni (fisse) per scaletta SHORT
Guards (fixed) for SHORT ladder

WINNER
L W 150
H Ht 35
Sp Ht 2,5

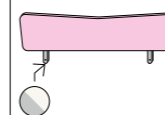

MASCHERA
L W 150
H Ht 24

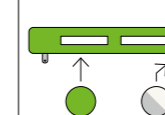

Protezioni (fisse)
Guards (fixed)

WINNER
L W 189
H Ht 35
Sp Ht 2,5

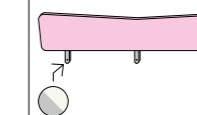

MASCHERA
L W 183
H Ht 24

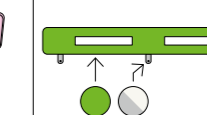

COD.	VF33.17F	VF33.18N	VF33.22D	VF33.23L
A				
B				

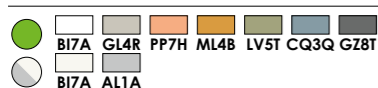

pag. 42
pag. 150

Posizionamento pomelli e maniglie
Knobs and handles position
Reti, materassi e guanciali
Bed bases, mattresses and pillows

Letti scorrevoli SPIKE

SPIKE sliding beds

Accessori per letti

Beds accessories

Informazioni tecniche:

Technical information:

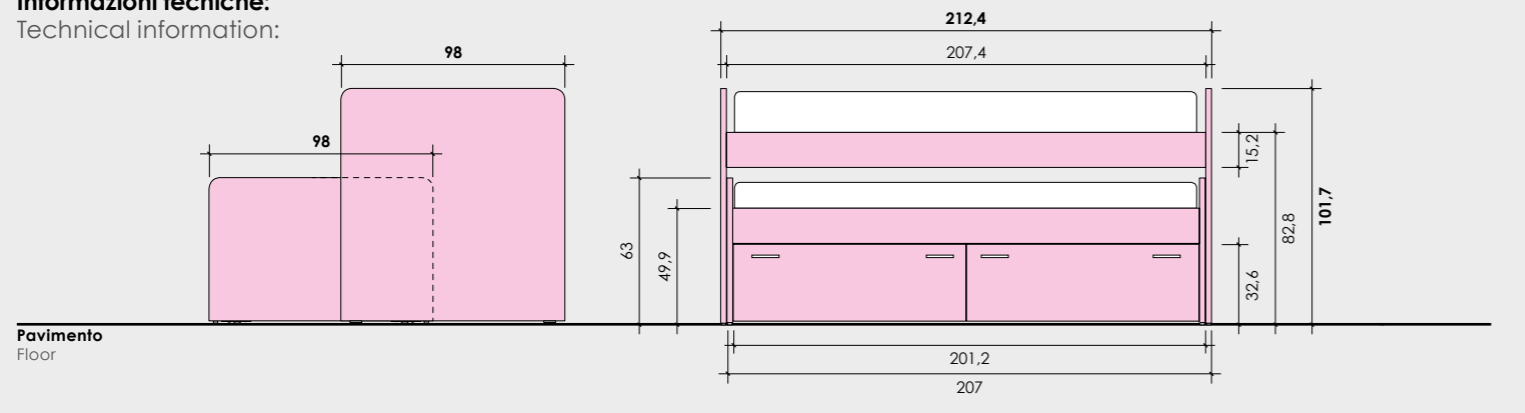

Coppie letti. Letti superiori fissi, inferiori con ruote autofrenanti.

Couples beds. Fixed upper beds, lower beds with self-braking wheels.

Letto inferiore con due reti

Lower bed with two bed bases

H	Ht	101,7
P	Dpt	212,4
L	W	98

Letto inferiore con cassettoni

Lower bed with bed big drawers

H	Ht	101,7
P	Dpt	212,4
L	W	98

Reti estraibile L 90.
Materasso L 90 H 23 max.
Pull-out bed base W 90.
Mattress W 90 Ht 23 cm max.

I cassettoni sono fissati alla struttura tramite guide.
The big drawers are fixed to the structure by means of runners.

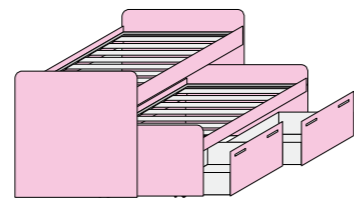
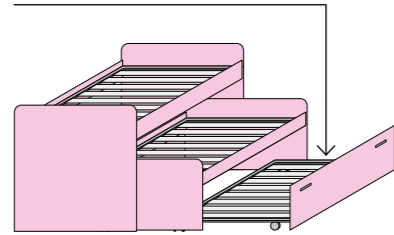

reti L bed bases W	COD.	COD.
90 x 200	VF22.85Y	VF22.86E

Scaletta in metallo SHORT

SHORT metal ladder

con fissaggio
with fixing

L	W	35
H	Ht	88



COD.	VF22.62T
-------------	----------

Protezioni (fisse) per scaletta SHORT

Guards (fixed) for SHORT ladder

WINNER

L	W	150
H	Ht	35
Sp	Ht	2,5

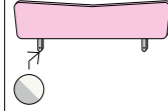

MASCHERA

L	W	150
H	Ht	24

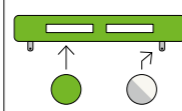

Protezioni (fisse)

Guards (fixed)

WINNER

L	W	189
H	Ht	35
Sp	Ht	2,5

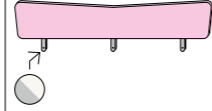

MASCHERA

L	W	183
H	Ht	24

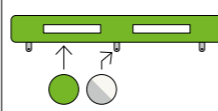

COD.	VF33.17F	VF33.18N	VF33.22D	VF33.23L
-------------	----------	----------	----------	----------

● B17A	■ GL4R	■ PP7H	■ ML4B	■ LV5T	■ CQ3Q	■ GZ8T
● B17A	■ AL1A					

■ Tessuto ECOCHIC	■ Z80B	■ Z81G	■ Z83P	■ Z84S	■ Z85V	■ Z82L
ECOCHIC fabric	■ Z20B	■ Z41G	■ Z21R	■ Z62R	■ Z64X	■ Z79Y
■ Similpelle ECOCHIC						
ECOCHIC faux leather						

Sponde su misura

Customized side panels

Reti a cura del cliente. In fase d'ordine è indispensabile indicare L della rete.

Base to be supplied by the customer. When ordering, you must state the width of base.

senza piastre per rete con piedi
without plates for base with feet

H	Ht	15,2
Sp	Th	2,5

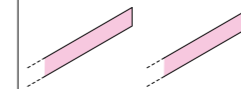

con piastre per rete senza piedi
with plates for base without feet

H	Ht	15,2
Sp	Th	2,5

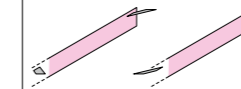

Coppia cassettoni sottoletto

Pair of under-bed big drawers

Con ruote
With wheels

H	Ht	24,6
L	W	97 x 2



L W	COD.	COD.	COD.	VF31.00W
95÷230	VF33.92S	VF33.93Y	VOLO	

Fodere di rivestimento in tessuto o similpelle

Fabric and faux leather covers

In fase d'ordine specificare per rete P 190 o 200.
When ordering, specify for bed base Dpt 190 or 200.

Per letti con rete fissa e rialzabile
For beds with fixed and lifting base

KANT

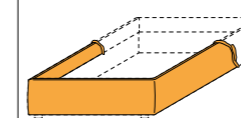

TWIN

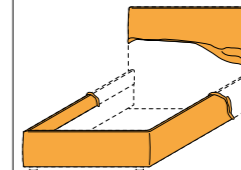

L W	COD.	P Dpt 190	P Dpt 200	COD.	P Dpt 190	P Dpt 200
90	VF33.94E			VF33.95M		
120	VF33.96T			VF33.97Z		
140	-			VF35.39P		
150	-			VF35.40L		
160	VF33.98F			VF33.99N		
180	-			VF35.41S		
200	-			VF35.42Y		

Kit illuminazione led per testate letti.

Led lighting kit for bed headboards.

Fascia led L 120, 1 interruttore, cablaggi
Led strip W 120, 1 switch, wiring

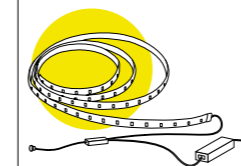

COD.	VF34.00K
-------------	----------

pag. 42
pag. 150

Posizionamento pomelli e maniglie
Knobs and handles position
Reti, materassi e guanciali
Bed bases, mattresses and pillows



Reti a doghe
Slatted bed bases

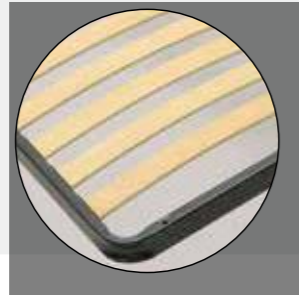

- **TUBOLARE:** tubolare 40 x 28 mm con traverse 30 x 30 ad alta resistenza.
- **DOGHE:** doghe in betulla 68 x 8 mm.
- **VERNICIATURA:** verniciatura polvere epossidica nera.

- **TUBULAR MEMBERS:** 40 x 28 mm tubular members with high strength 30 x 30 cross bars.
- **SLATS:** birch slats of 68x8 mm.
- **PAINTING:** black epoxy powder painted finish.

- A** Rete senza piedi
Base without feet
- B** Rete con piedi (pieghevoli)
Base with feet (foldable)
- C** Rete con piedi (smontabili)
Base with feet (removable)
- D** Rete estraibile con ruote (con piedi pieghevoli)
Pull-out base with wheels (with foldable feet)

H Ht	P Dpt	L W	COD.
-	190	80	VF33.66B
		90	VF34.18S
		120	VF34.19Y
		160	VF34.20V
-	200	80	-
		90	VF35.15B
		120	VF35.16H
29	190	80	VF34.23Q
		90	VF34.24W
		120	VF34.25C
29	190	160	VF34.26K
		120	-
29	200	160	VF34.27R
		5÷30	190
5÷30	200	90	VF35.62K

Rete a doghe avvolgibile
Roll-up slatted base

L W 80
P Dpt 190



COD.	VF33.20R
	127,00



CAPRI

Materasso 400 molle biconiche Bonnell
400 Bonnell hourglass springs mattress

- **1 TESSUTO:** Elasticizzato con trattamento anallergico. Fisso.
- **2 IMBOTTITURA:** Lato invernale: Fibra PolyFill Termal (lana selezionata + fibra poliestere anallergica). Lato estivo: Fibra PolyFill Fresh (cotone selezionato + fibra poliestere anallergica).
- **3 STRUTTURA:** Molle biconiche Bonnell "400" (densità circa 400 molle, nella versione matrimoniale) + poliuretano alto spessore con profilo sagomato.
- **PORTANZA:** Rigido.
- **SPESORE:** H cm. 21 ca: con maniglie. H cm. 17 ca: senza maniglie.

- **1 FABRIC:** Stretch with anti-allergy treatment. Fixed.
- **2 UPHOLSTERY:** Winter side: PolyFill Termal fibre (high grade wool + anti-allergy polyester fibre). Summer side: PolyFill Fresh fibre (high grade cotton + anti-allergy polyester fibre).
- **3 STRUCTURE:** Bonnell "400" hourglass springs (density approximately 400 springs in the Double version) + thick polyurethane with shaped profile.
- **RIGIDITY:** Firm.
- **THICKNESS:** Ht 21 cm approx. with handles. Ht 17 cm approx. without handles.

H Ht	P Dpt	L W	Kg	COD.
17	190	80	11,5	VF33.39E
		90	12,9	VF33.71Z
21	190	80	13	VF33.40B
		90	14,6	VF33.72F
		120	19,5	VF33.77P
21	190	160	26	VF34.01R
		80	14	VF33.44C
		90	15,8	VF33.76G
21	190	120	21	VF33.81E
		160	28	VF34.02X
		80	-	-
		90	15,4	VF33.45K
21	200	120	20,5	VF33.50G
		140	23,9	VF35.18W
		150	25,7	VF35.22N
		160	27,4	VF34.03D
		180	30,8	VF35.26P
		200	34,2	VF35.33Z
21	200	80	-	-
		90	16,6	VF33.49L
		120	-	-
		160	29,5	VF34.04L
180	33,2	VF35.27V		



LIPARI

Materasso in Ecofoam (schiumato ad acqua, cellula aperta traspirante)
Ecofoam mattress (water foamed, breathable open cell)

- **COVER:** Sfoderabile e lavabile in acqua a 30°C.
- **TESSUTO:** Elasticizzato, trattamento anallergico e cerniera centrale su tre lati.
- **IMBOTTITURA:** 100% fibra Polyfill anallergica traspirante.
- **STRUTTURA:** 1 Strato di EcoFoam (poliuretano espanso a cellula aperta, schiumato ad acqua) con profilo multizona. 2 Strato in alto spessore in EcoFoam (poliuretano a cellula aperta, schiumato ad acqua) profilo ad ondine.
- **PORTANZA:** 1 Rigido. 2 Medio.
- **SPESORE:** H cm. 17 ca: (lastra spessore cm. 15,5 ca).

- **COVER:** Covers can be removed and washed in water at 30°C.
- **FABRIC:** Stretch with anti-allergy treatment and central zip fastener on three sides.
- **UPHOLSTERY:** 100% breathable anti-allergy Polyfill fibre.
- **STRUCTURE:** 1 Layer of EcoFoam (water-foamed open-cell polyurethane foam) with multizone profile. 2 Thick layer of EcoFoam (water-foamed open-cell polyurethane) with wave profile.
- **RIGIDITY:** 1 Firm. 2 Medium.
- **THICKNESS:** Ht 17 cm approx. (main body 15.5 cm approx.).

H Ht	P Dpt	L W	Kg	COD.
17	190	80	8	VF33.41H
		90	9	VF33.73N
		120	12	VF33.78V
17	200	160	16	VF34.05S
		80	-	-
		90	9,5	VF33.46R
17	200	120	12,6	VF33.51P
		140	14,7	VF35.19C
		150	15,8	VF35.23U
		160	16,8	VF34.06Y
		180	18,9	VF35.28B
		200	21,1	VF35.34F



ELBA

Materasso in Ecofoam + Termo-visco memory foam
Ecofoam mattress + Visco-elastic memory foam

- **COVER:** Silver Air: tessuto anallergico con trattamento a base di argento, sfoderabile e lavabile in acqua 30°C.
- **TESSUTO:** Elasticizzato trattamento Silver Fresh.
- **FASCIA PERIMETRALE:** Air System in tessuto riflettere alta traspirazione, sfoderabile, con maniglie e doppia cerniera perimetrale con divisibile.
- **IMBOTTITURA:** 100% fibra Polyfill anallergica traspirante antipolvere (sui due lati).
- **STRUTTURA:** 1 Strato di Termo Visco Memory Foam (termosensibile Viscoelastico) H cm 3 multizona (lato invernale) profilo ad ondine multizona. 2 Strato in alto spessore in EcoFoam (poliuretano a cellula aperta, schiumato ad acqua, densità medio/alta).
- **3 Strato di EcoFoam Ultrasoff** H 2,5 cm (lato estivo) profilo ad ondine multizona.
- **PORTANZA:** Medio/alta comfort.
- **SPESORE:** H 21 cm ca: (lastra Sp 18 cm ca).

- **COVER:** SilverAir: silver-treated anti-allergy fabric, can be removed and washed in water at 30°C.
- **FABRIC:** Stretch, Silver Fresh treatment.
- **EDGE BAND:** Air System in highly breathable mesh fabric, removable, with handles and twin edge zip fasteners for separation.
- **UPHOLSTERY:** 100% breathable, dust-proof anti-allergy Polyfill fibre (on both sides).
- **STRUCTURE:** 1 Layer of temperature-sensitive Visco-Elastic Memory Foam Ht 3 cm, multizone (winter side), multizone wave profile. 2 Thick layer of EcoFoam (medium/high density water-foamed open-cell polyurethane). 3 Layer of Ultrasoff EcoFoam Ht 2.5 cm (summer side) with multizone wave profile.
- **RIGIDITY:** Medium/high comfort.
- **THICKNESS:** Ht 21 cm approx. (main body 18 cm approx.).

H Ht	P Dpt	L W	Kg	COD.
21	190	80	10	VF33.42Q
		90	11,3	VF33.74U
		120	15	VF33.79B
21	190	160	20	VF34.07E
		80	-	-
		90	11,8	VF33.47X
21	200	120	15,8	VF33.52V
		140	18,4	VF35.20Z
		150	19,7	VF35.24A
		160	21,1	VF34.08M
		180	23,7	VF35.29H
		200	26,3	VF35.35N

- Anallergico**
Non-allergenic
- Antistatico**
Antistatic
- Ecologico e riciclabile**
Ecological and recyclable

- Bonnell system**
Bonnell system
- Sfoderabile e lavabile in acqua**
Removable and washable in water
- Schiumato ad acqua**
Water foam

- Non pieghevole**
Not folding
- Pieghevole**
Folding
- Totale ergonomia**
Complete ergonomics

- Doppia portanza**
Double support
- Termo memory foam**
Termo memory foam

Ignifugo in Classe 11M (Omologato dal Ministero degli Interni) con graffatura a punto metallico degli strati interni
Fireproof Class 11M (approved by the Ministry of the Interior) with metal point seams on the inner layers



ALICUDI

Materasso 1600 molle insacchettate micropocket
1600 micro-pocket springs mattress

- **1** TESSUTO: Elasticizzato con trattamento allergico. Fisso.
- **2** IMBOTTITURA: Lato invernale: strato di 100% pura fibra PolyFill Termal (lana selezionata + fibra poliestere anallergica) + strato di poliuretano. Lato estivo: strato di 100% pura fibra PolyFill Fresh (cotone selezionato + fibra poliestere anallergica) + strato di poliuretano.
- **3** STRUTTURA: Micro-molle insacchettate (densità circa 1600 molle, nella versione matrimoniale) a movimento indipendente con strato di poliuretano alto spessore con profilo ad ondine sui due lati.
- PORTANZA: Medio-alta.
- SPESSORE: H cm. 23 ca.



SALINA

Materasso pocket memory
Mattress pocket memory

- TESSUTO: Elasticizzato con trattamento allergico Aloe Vera. Fisso.
- IMBOTTITURA: Lato invernale/estivo: doppio strato di 100% pura fibra PolyFill anallergica ad alta traspirazione.
- STRUTTURA: **1** Molle insacchettate a zone differenziate (circa 800/1000 molle nella versione matrimoniale) a movimento indipendente. **2** Strato di Termo Visco Memory H 3 cm (su un lato) con profilo ad ondine multizona e strato di EcoFoam H 2,5 cm ca con profilo multizona (su un lato).
- PORTANZA: Media-alta.
- SPESSORE: H 23 cm ca.



PALMAROLA

Materasso high comfort memory
Mattress high comfort memory

- TESSUTO: Elasticizzato con trattamento allergico Aloe Vera. Cover sfoderabile e lavabile in acqua 30° C.
- IMBOTTITURA: Lato invernale/estivo: doppio strato di 100% pura fibra PolyFill anallergica ad alta traspirazione.
- STRUTTURA: **1** Strato di Termo Visco Memory (termosensibile - viscoelastico) H 5 cm multizona (lato invernale); **2** Strato centrale in EcoFoam (poliuretano a cellula aperta, schiumato ad acqua) ad alta portanza, con profilo ad ondine **3** Strato di EcoFoam Alta elasticità H 2 cm (lato estivo).
- PORTANZA: Differenziata sui due lati.
- SPESSORE: H 22 cm ca (lastra spessore 19 cm ca).



PONZA

Guanciale
Pillow

- TESSUTO: Fisso puro cotone 100%.
- STRUTTURA: Anima in fibra anallergica, antipolvere.
- LAVABILITÀ: Interamente lavabile in acqua a 30°C.
- DIMENSIONI IN cm: 80 x 50 x 10 ca.
- Guanciale in fibra anallergica. Ideale per chi gradisce un cuscino di buona consistenza e di media altezza, per tutti. L'imbottitura in fibra anallergica a struttura cava a 3 vie permette la massima circolazione d'aria, senza infeltrire e rimanendo morbida e confortevole nel tempo.
- FABRIC: Fixed, 100% pure cotton.
- STRUCTURE: Anti-allergy, dust-proof fibre core.
- WASHABILITY: Completely washable in water at 30°C.
- DIMENSIONS IN cm: 80 x 50 x 10 approx.
- Anti-allergy fibre pillow. Ideal for those who prefer a medium-high, firm pillow, suitable for all. The anti-allergy three-way hollow fibre filling allows excellent air circulation without felting, and stays soft and comfortable over time.

COD.	
VF34.15X	



PROCIDA

Guanciale
Pillow

- TESSUTO: Elasticizzato traspirante, anallergico. Fisso.
- STRUTTURA: Anima in EcoFoam UltraSoft a saponetta con inserto massaggiante in Thermo-Visco Memory Touch nella zona accoglienza nuca.
- DIMENSIONI IN cm: 68 x 38 x 10/11 approx.
- Guanciale anallergico in EcoFoam UltraSoft, a saponetta con inserto massaggiante in Thermo-Visco Memory Touch nella zona di accoglienza nuca (sui due lati).
- FABRIC: Stretch, breathable, anti-allergy. Fixed.
- STRUCTURE: UltraSoft EcoFoam block core with Memory Touch Visco-Elastic massaging insert in the neck area.
- DIMENSIONS IN cm: 68 x 38 x 10/11 approx.
- Anti-allergy pillow in UltraSoft EcoFoam core with Memory Touch Visco-Elastic massaging insert in the neck area (on both sides).

COD.	
VF34.16D	



MALVA

Guanciale
Pillow

- TESSUTO: Elasticizzato traspirante, anallergico. Fisso.
- STRUTTURA: Anima in lattice microforato con forma a saponetta.
- DIMENSIONI IN cm: 72 x 42 x 10 ca.
- Guanciale anallergico in lattice microforato. Il guanciale in lattice è molto confortevole ed antibatterico.
- FABRIC: Stretch, breathable, anti-allergy. Fixed.
- STRUCTURE: Micro-perforated latex block core.
- DIMENSIONS IN cm: 72 x 42 x 10 approx.
- Micro-perforated latex anti-allergy pillow. Latex pillows are very comfortable and bacteria-resistant.

COD.	
VF34.17L	

H Ht	P Dpt	L W	Kg	COD.
23	190	80	14,8	VF33.43W
		90	16,6	VF33.75A
		120	22,1	VF33.80Y
		160	29,5	VF34.09T
23	200	80	-	-
		90	17,5	VF33.48D
		120	23,3	VF33.53B
		140	27,2	VF35.21F
		150	29,1	VF35.25G
		160	31,1	VF34.10Q
		180	34,9	VF35.30E
200	38,8	VF35.36U		

H Ht	P Dpt	L W	Kg	COD.
23	190	160	35	VF34.11W
23	200	160	36,8	VF34.12C
		180	41,4	VF35.31M
		200	46,1	VF35.37A

H Ht	P Dpt	L W	Kg	COD.
22	190	160	20	VF34.13K
22	200	160	21,1	VF34.14R
		180	23,7	VF35.32T
		200	26,3	VF35.38G

- Anallergico Non-allergenic
- Antistatico Antistatic
- Ecologico e riciclabile Ecological and recyclable

- Micro-pocket 800-1000 Micro-pocket 800-1000
- Micro-pocket 1600 Micro-pocket 1600
- Sfoderabile e lavabile in acqua Removable and washable in water

- Schiumato ad acqua Water foam
- Lattice Latex
- Non pieghevole Not folding

- Pieghevole Folding
- Totale ergonomia Complete ergonomics
- Doppia portanza Double support

- Termo memory foam Termo memory foam
- Aloe vera Aloe vera

Tutti i Comò e Settimini sono dotati di ferramenta per fissaggio a muro antiribaltamento.
All the Dressers and Tallboys are equipped with anti-overturning wall fixing hardware.

FUSION

Apertura cassetti con pomelli e maniglie di serie o push-pull. La scelta della maniglia push-pull determinerà le guide tipo "Quadro" push-pull.
Drawers opening with standard knob and handle or push-pull. Selecting a push-pull handle will determine the need for "Quadro" type push-pull runners.

Piede ALFA non disponibile.
ALFA foot not available.

Cassetti con guide metalliche tipo "Quadro" rallentate di serie.
Drawers with slowed "Quadro" type metal runners as standard.

Comodino Bedside table

L W 45
P Dpt 45,8
H Ht 37,7



COD. VF06.70W

Comò Dresser

L W 120
P Dpt 57,1
H Ht 77,7

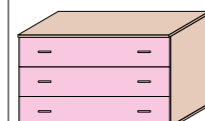

COD. VF06.71C

Settimino Tallboy

L W 45
P Dpt 45,8
H Ht 117,7

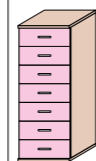

COD. VF06.73R

A
B

MASTER

Apertura cassetti con pomelli e maniglie di serie (no push-pull).
(maniglia BLADE non disponibile)
Drawers opening with standard knob and handle (no push-pull).
(BLADE handle not available)

Comodini Bedside tables

L W 45
P Dpt 45
H Ht 34,5



COD. VF06.30Z



COD. VF06.31F

Comò Dresser

L W 105
P Dpt 57,1
H Ht 70,6

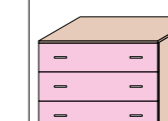

COD. VF06.32N

L W 120
P Dpt 57,1
H Ht 75,2

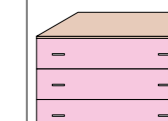

COD. VF06.34A

Settimino Tallboy

L W 45
P Dpt 45
H Ht 114,5

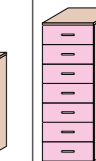

COD. VF06.35G

A
B

LINK

Apertura cassetto con presa laterale disponibile nei colori:
Drawer opening with lateral grip available in colors:

B17A
G28T

Cassetti con guide metalliche tipo "Quadro" rallentate di serie.
Drawers with slowed "Quadro" type metal runners as standard.

Comodino Bedside table

L W 45
P Dpt 47,3
H Ht 34,5



COD. VF06.03C

Comò Dresser

L W 120
P Dpt 58,6
H Ht 74,5

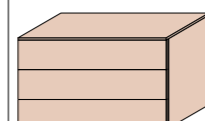

COD. VF06.04K

Settimino Tallboy

L W 45
P Dpt 47,3
H Ht 114,5

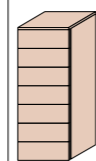

COD. VF06.05R

A
B

TRAY

Apertura cassetti con pomelli e maniglie di serie (no push-pull).
Drawers opening with standard knob and handle (no push-pull).

Comodino Bedside table

L W 48,6
P Dpt 47,4
H Ht 39,5



COD. VF06.63L

Comò Dresser

L W 123,6
P Dpt 58,4
H Ht 79,5



COD. VF06.64S

Settimino Tallboy

L W 63,6
P Dpt 47,4
H Ht 119,5

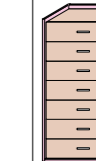

COD. VF06.65Y

A
B

LUKE

Apertura cassetti con maniglia gola, disponibile nei colori:
Drawers opening with groove is available in colors:

B17A
G28T

Cassetti con chiusura rallentata di serie.
Drawers with soft closing as standard.

Comodino Bedside table

L W 48,7
P Dpt 45
H Ht 39,1



COD. VF06.20U

Comò Dresser

L W 110,1
P Dpt 57,1
H Ht 78,4

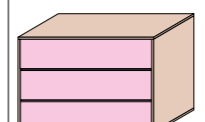

COD. VF06.21A

A
B

Accessori
Accessories

I Gruppi sono dotati di pattini salvamobile H 0,7.
A discrezione, se non diversamente indicato è possibile applicare i Piedini regolabili.
The Groups are equipped with H 0,7 "save furniture" feet.
At discretion, the Adjustable feet can be applied unless otherwise indicated.

Piedini regolabili - Confezione 4 pezzi Adjustable feet - Pack of 4 pieces

ALFA 25
L W 2,5

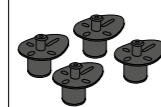

COD. VF32.32E

ETA
L W 10
H Ht 4

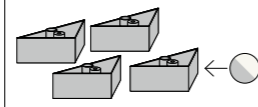

COD. VF32.33M

SIGMA
L W 8,3
H Ht 11

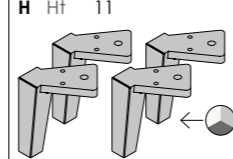

COD. VF32.34T

B17A AL1A G28T
B17A AL1A

Sovrapprezzi per rallentatore chiusura:
Surcharge for closing retainer:

+ 13,00 CASSETTO Comodino e Settimino (MASTER)
Bedside table and Tallboy DRAWER (MASTER)
+ 25,00 CASSETTO Comò (MASTER)
Dresser DRAWER (MASTER)

pag. 42

Posizionamento pomelli e maniglie
Knobs and handles position

Specchiere Mirrors

• Posizionabili sia verticali che orizzontali

• Positioned both vertical and horizontal

Con cornice

With frame

PINTA 1

L W 80
H Ht 80
Sp Th 2,5

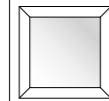

Colori disponibili:
Available colours:
NB5T BI7A GL4R

PINTA 2

L W 80
H Ht 190
Sp Th 2,5



Colori disponibili:
Available colours:
NB5T BI7A GL4R

PINTA 3

L W 60
H Ht 112
Sp Th 2,5



Colori disponibili:
Available colours:
NB5T BI7A GL4R

COD.	VF06.80B	VF06.81H	VF06.82Q
------	----------	----------	----------

Con specchio Sp 0,4 applicato su pannello in nobilitato Sp 1,8

With mirror Th 0,4 on melamine panel Th 1,8

QUADRO 1

L W 95,6
H Ht 68,7
Sp Th 2,2

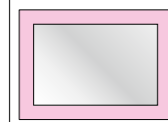

QUADRO 2

L W 95,6
H Ht 68,7
Sp Th 2,2

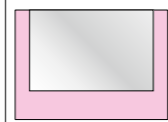

QUADRO 3

L W 95,6
H Ht 68,7
Sp Th 2,2



QUADRO 4

L W 95,6
H Ht 68,7
Sp Th 2,2

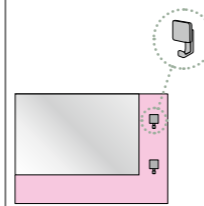

COD.	VF06.83W	VF06.84C	VF06.85K	VF06.86R
	(A)			
	(B)			

Con specchio Sp 0,4 applicato su pannello in nobilitato

With mirror Th 0,4 on melamine panel

WINNER

L W 104
H Ht 79
Sp Th 2,2

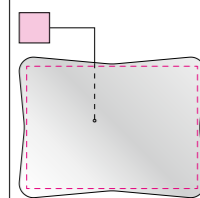

COD.	VF06.87X
	(A)
	(B)

Accessori Accessories

PLUS appendiabiti clothes hook

L W 4,3
P Dpt 3
H Ht 6,5



SEED Ø 5,2 3 appendiabiti 3 clothes hook

Ø 5,2
P Dpt 2,4



COD.	VF32.62W	VF35.63R
------	----------	----------



Facciate Fronts
VOLO

Finiture GRUPPO 1
GROUP 1 finishes

Finiture GRUPPO 2
GROUP 2 finishes

Rovere white*

(A) ☆	(A) ☆	(A)	(A)	(B) ☆	(B) ☆
Rovere white RW3Q	Noce brina NB5T	Bianco opaco B17A	Grigio Dorian GL4R	Cemento artico CA7A	Rovere gesso RG9L
(B) ☆	(B) ☆	(B)			
Royal oak RS4B	Rovere cognac RC3Q	Grigio titanio GZ8T			
(B)	(B)	(B)	(B)		
Papaya PP7H	Miele ML4B	Oliva LV5T	Cadaques CQ3Q		

Vetri Glass

Ante Doors
WINDOW

				Colori telaio Frame colours	
Trasparente TR9M	Trasparente fumé FT8P	Stop sol ST6P	Specchio SP7L		
				Alluminio AL1A	Titan grey TG7H

SCRIVANIE, MENSOLE E CUBOLOTTI
DESKS, SHELVES AND CUBES

Scrivanie BANNER - H 77,6 P 57,1 BANNER desks - Ht 77.6 Dpt 57.1	pag. 160
Scrivanie WINNER - H 77,6 P 63,5 WINNER desks - Ht 77.6 Dpt 63.5	pag. 162
Scrivanie SWITCH - H 77,6 P 63,3 SWITCH desks - Ht 77.6 Dpt 63.3	pag. 164
Scrivanie ICS - H 77,6 P 57,1 ICS desks - Ht 77.6 Dpt 57.1	pag. 166
Scrivanie CORNER - H 77,6 P 90 CORNER desks - Ht 77.6 Dpt 90	pag. 167
Scrivanie ARCON con carrello H 77,6 - P 59,5 ARCON desks with trolley Ht 77.6 - Dpt 59.5	pag. 168
Scrivanie ALPA - H 77,6 ALPA desks - Ht 77.6	pag. 169
Scrivanie sospesa FLOW - L 120 P 47,3 FLOW suspended desk - W 120 Dpt 47.3	pag. 170
Accessori per scrivanie Desks accessories	pag. 171
Mensole - Sp 2,5 P 26 Shelves - Th 2.5 Dpt 26	pag. 172
Cubolotti Cubes	pag. 174
Pannelli attrezzati STRIP - P 20 STRIP equipped panels - Dpt 20	pag. 176
Pannelli attrezzati BING - P 28,5 BING equipped panels - Dpt 28.5	pag. 176
Pannelli attrezzati PILL - P 28,5 PILL equipped panels - Dpt 28.5	pag. 177
Pannelli attrezzati DROP - P 20,5 DROP equipped panels - Dpt 20.5	pag. 177
Pannelli attrezzati EXPILON - P 28,5 EXPILON equipped panels - Dpt 28.5	pag. 178
Pannelli attrezzati porta TV - H 90 Equipped panels for TV - Ht 90	pag. 179
Pannelli attrezzati STRANGE - H 90 STRANGE equipped panels - Ht 90	pag. 180

Rovere white* Finitura unica per tutti i componenti in pannello presenti a listino non evidenziati con il colore Finiture GRUPPO 1 e/o Finiture GRUPPO 2.
Unique finish for all the panel components shown in the pricelist not highlighted with the color finishes GROUP 1 and/or finishes GROUP 2.

- A** Finiture in fascia di prezzo A
Finishes in price range A
- B** Finiture in fascia di prezzo B
Finishes in price range B
- ☆ Finiture con effetto materico
Finishes with textured effect

Scrivanie BANNER - H 77,6 P 57,1

BANNER desks - Ht 77.6 Dpt 57.1

Piano BANNER Sp 2,5 bordato in ABS
Fianchi in pannello Sp 1,8

BANNER top Th 2.5 with ABS edging
Side panels Th 1.8

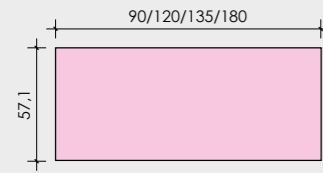

- In presenza di due gambe ONE o THREE si consiglia di fissare la scrivania al muro con la ferramenta in dotazione.
- In the presence of two legs "ONE" or "THREE" it is advisable to fix the desk to the wall with the hardware supplied.

Nel momento in cui si ordina una scrivania L120-135-180 è possibile dotarla di accessori integrati per i quali è necessaria l'esecuzione di fori sui piani (foratura a nostra cura). Possono essere scelti uno o più accessori:



• Ricarica wireless + presa USB
Wireless charging + USB socket



• Copriforo per passacavi
Cover for wire leads

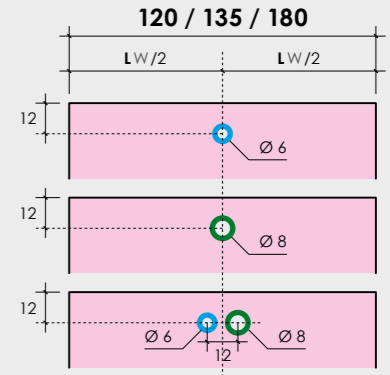

L
W 90

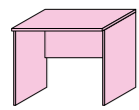

COD. VF15.00G

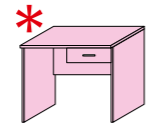

COD. VF15.01P

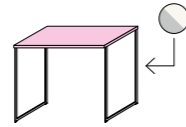

COD. VF15.02V

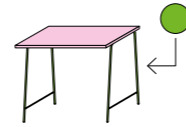

COD. VF15.03B

A
B

L
W 120

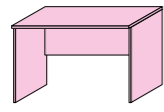

COD. VF15.04H

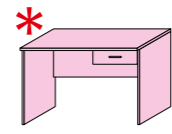

COD. VF15.05Q

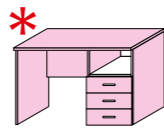

COD. VF15.06W

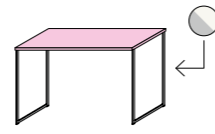

COD. VF15.07C

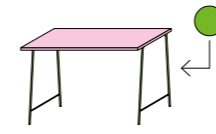

COD. VF15.08K

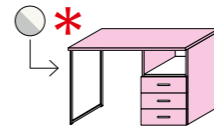

COD. VF15.09R

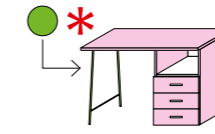

COD. VF15.10N

A
B

L
W 135

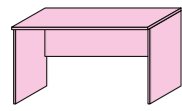

COD. VF15.11U

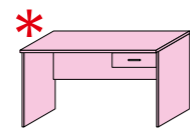

COD. VF15.12A

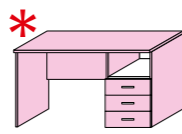

COD. VF15.13G

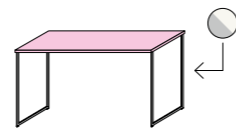

COD. VF15.14P

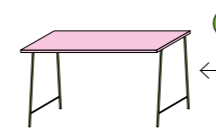

COD. VF15.15V

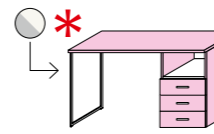

COD. VF15.16B

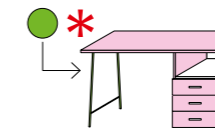

COD. VF15.17H

A
B

L
W 180

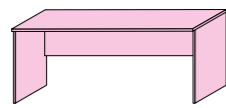

COD. VF15.18Q

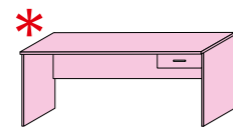

COD. VF15.19W

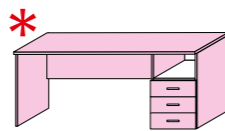

COD. VF15.20T

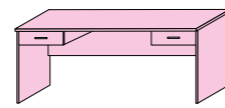

COD. VF15.21Z

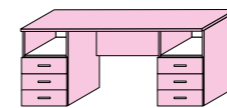

COD. VF15.22F

A
B

L su misura
Custom W

min 45 - max 220

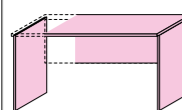

COD. VF15.23N

min 91 - max 220

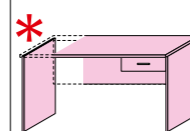

COD. VF15.24U

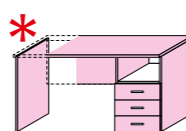

COD. VF15.25A

A
B

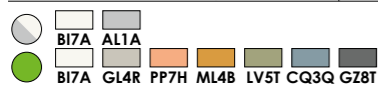

* Specificare Sx o Dx (disegno Dx)
Specify L or R (R drawing)

Sovrapprezzi per rallentatore chiusura:
Surcharge for closing retainer:

CASSETTO
DRAWER

pag. 42
pag. 171

Posizionamento pomelli e maniglie
Knobs and handles position
Accessori per scrivanie
Desks accessories

Scrivanie WINNER - H 77,6 P 63,5

WINNER desks - Ht 77.6 Dpt 63.5

Piano WINNER Sp 2,5 bordato in ABS
Fianchi in pannello Sp 1,8

WINNER top Th 2.5 with ABS edging
Side panels Th 1.8

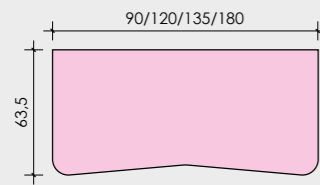

- In presenza di due gambe ONE o THREE si consiglia di fissare la scrivania al muro con la ferramenta in dotazione.
- In the presence of two legs "ONE" or "THREE" it is advisable to fix the desk to the wall with the hardware supplied.

Nel momento in cui si ordina una scrivania è possibile dotarla di accessori integrati per i quali è necessaria l'esecuzione di fori sui piani (foratura a nostra cura).
Possono essere scelti uno o più accessori:

When ordering a desk, it can be fitted with built-in accessories requiring holes to be drilled in the tops (drilled by us).
One or more accessories can be chosen:



• Ricarica wireless + presa USB
Wireless charging + USB socket



• Copriforo per passacavi
Cover for wire leads

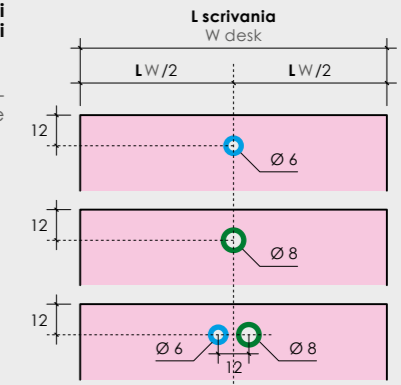

L
W 90

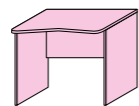

COD. VF15.30Y

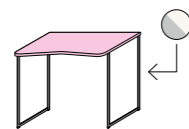

COD. VF15.31E

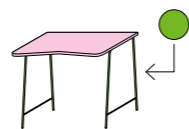

COD. VF15.32M

A
B

L
W 120

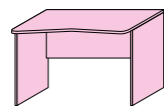

COD. VF15.33T

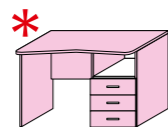

COD. VF15.34Z

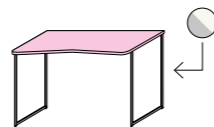

COD. VF15.35F



COD. VF15.36N

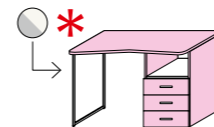

COD. VF15.37U

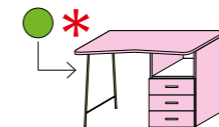

COD. VF15.38A

A
B

L
W 135

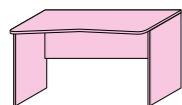

COD. VF15.39G

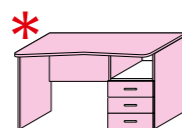

COD. VF15.40D

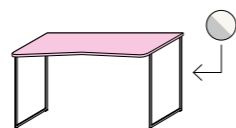

COD. VF15.41L

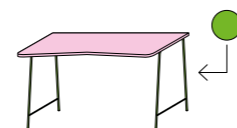

COD. VF15.42S

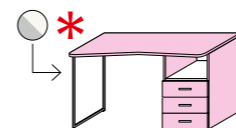

COD. VF15.43Y

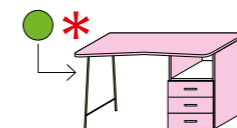

COD. VF15.44E

A
B

L
W 180

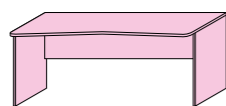

COD. VF15.45M

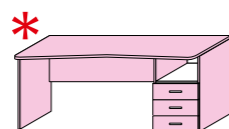

COD. VF15.46T

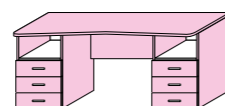

COD. VF15.47Z

A
B

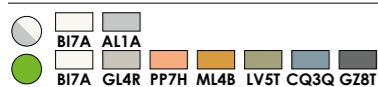

* Specificare Sx o Dx (disegno Dx)
Specify L or R (R drawing)

Sovrapprezzi per rallentatore chiusura:
Surcharge for closing retainer:

CASSETTO
DRAWER

pag. 42
pag. 171

Posizionamento pomelli e maniglie
Knobs and handles position
Accessori per scrivanie
Desks accessories

Scrivanie SWITCH - H 77,6 P 63,3

SWITCH desks - Ht 77.6 Dpt 63.3

Piano SWITCH Sp 2,5 bordato in ABS
Fianchi sagomati in pannello Sp 2,5
SWITCH top Th 2.5 with ABS edging
Shaped side panels Th 2.5

• In presenza di due gambe ONE o THREE si consiglia di fissare la scrivania al muro con la ferramenta in dotazione.
• In the presence of two legs "ONE" or "THREE" it is advisable to fix the desk to the wall with the hardware supplied.

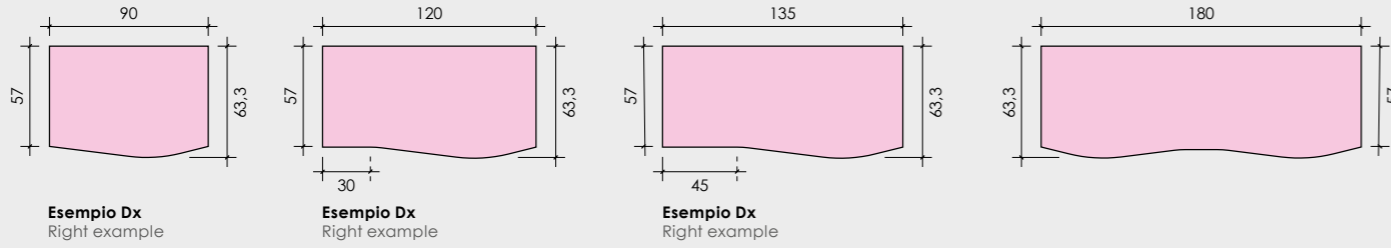

Nel momento in cui si ordina una scrivania è possibile dotarla di accessori integrati per i quali è necessaria l'esecuzione di fori sui piani (foratura a nostra cura).
Possono essere scelti uno o più accessori:
When ordering a desk, it can be fitted with built-in accessories requiring holes to be drilled in the tops (drilled by us).
One or more accessories can be chosen:

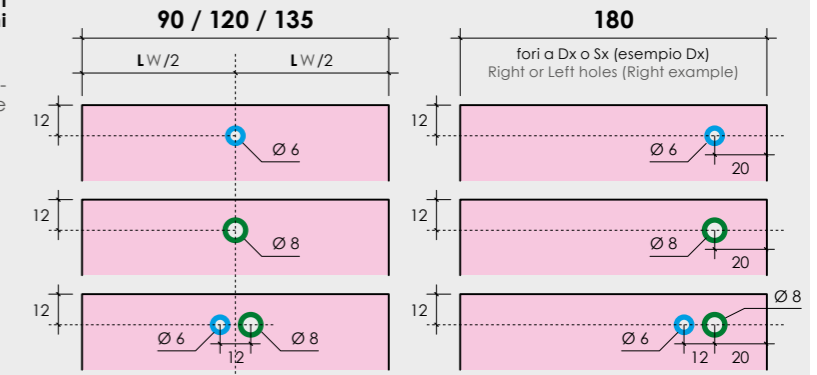
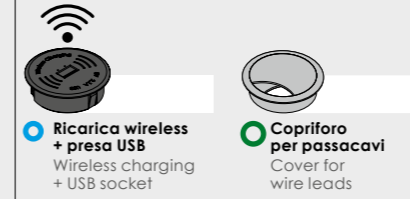

L
W 90

Specificare Sx o Dx (disegno Dx)
Specify L or R (R drawing)

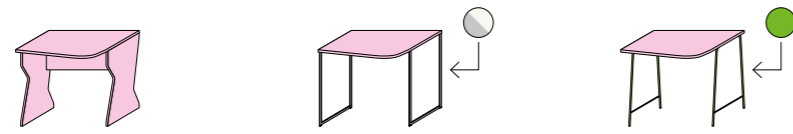

COD. VF15.50K VF15.51R VF15.52X

A
B

L
W 120

Specificare Sx o Dx (disegno Dx)
Specify L or R (R drawing)

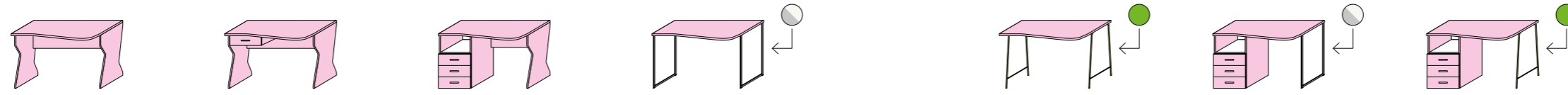

COD. VF15.53D VF15.54L VF15.55S VF15.56Y VF15.57E VF15.58M VF15.59T

A
B

L
W 135

Specificare Sx o Dx (disegno Dx)
Specify L or R (R drawing)

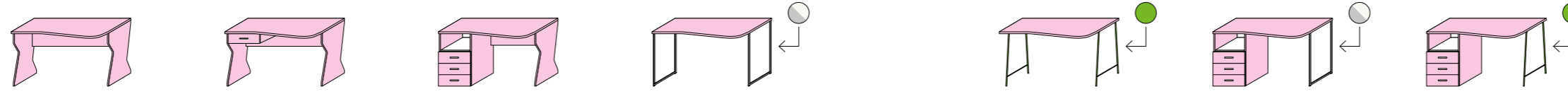

COD. VF15.60Q VF15.61W VF15.62C VF15.63K VF15.64R VF15.65X VF15.66D

A
B

L
W 180

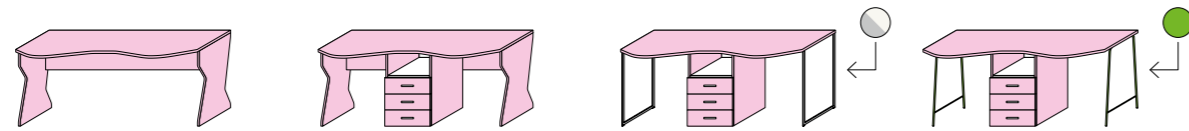

COD. VF15.67L VF15.68S VF15.69Y VF15.70V

A
B

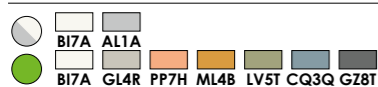

Sovrapprezzi per rallentatore chiusura:
Surcharge for closing retainer:

CASSETTO
DRAWER

pag. 42
pag. 171

Posizionamento pomelli e maniglie
Knobs and handles position
Accessori per scrivanie
Desks accessories

Scrivanie ICS - H 77,6 P 57,1

ICS desks - Ht 77.6 Dpt 57.1

Piano ICS Sp 2,5 bordato in ABS
Fianchi sagomati in pannello Sp 2,5
ICS top Th 2.5 with ABS edging
Shaped side panels Th 2.5

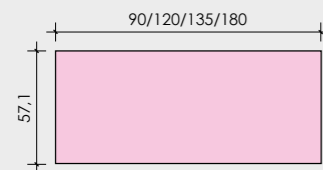

Nel momento in cui si ordina una scrivania è possibile dotarla di accessori integrati per i quali è necessaria l'esecuzione di fori sui piani (foratura a nostra cura).
Possono essere scelti uno o più accessori:
When ordering a desk, it can be fitted with built-in accessories requiring holes to be drilled in the tops (drilled by us).
One or more accessories can be chosen:



Ricarica wireless + presa USB
Wireless charging + USB socket



Copriforo per passacavi
Cover for wire leads

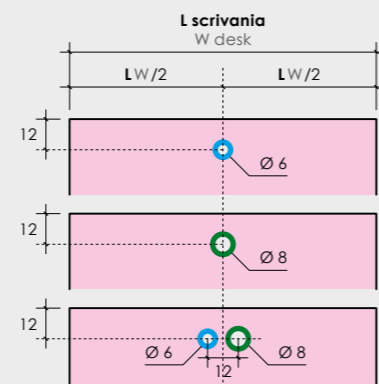

Scrivanie CORNER - H 77,6 P 90

CORNER desks - Ht 77.6 Dpt 90

Piano sagomato CORNER Sp 2,5 bordato in ABS (Sx)
CORNER shaped top Th 2.5 with ABS edging (L)

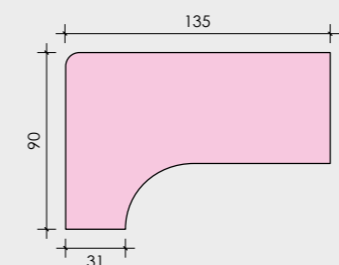

Nel momento in cui si ordina una scrivania è possibile dotarla di accessori integrati per i quali è necessaria l'esecuzione di fori sui piani (foratura a nostra cura).
Possono essere scelti uno o più accessori:
When ordering a desk, it can be fitted with built-in accessories requiring holes to be drilled in the tops (drilled by us).
One or more accessories can be chosen:



Ricarica wireless + presa USB
Wireless charging + USB socket



Copriforo per passacavi
Cover for wire leads

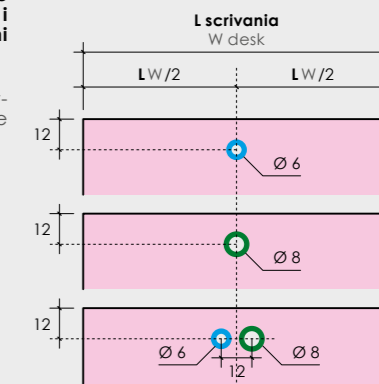

L
W **90**



COD. VF15.80A

A
B

L
W **120**

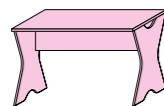

COD. VF15.81G VF15.82P

A
B

L
W **135**

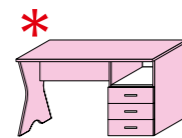
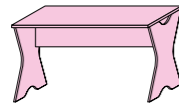

COD. VF15.83V VF15.84B

A
B

L
W **180**

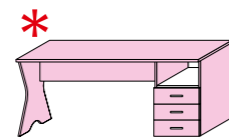
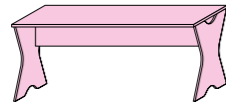

COD. VF15.85H VF15.86Q

A
B

L
W **135**

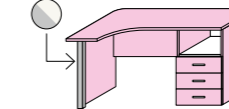
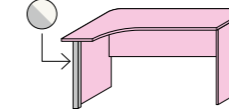

Sx L

COD. VF16.00M VF16.01T

A
B

L
W **135**

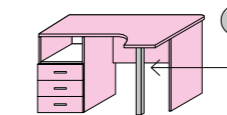
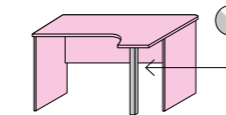

Dx R

COD. VF16.02Z VF16.03F

A
B

Scrivanie ARCON con carrello H 77,6 - P 59,5

ARCON desks with trolley Ht 77.6 - Dpt 59.5

Piano sagomato ARCON Sp 2,5 bordato in ABS.
ARCON shaped top Th 2.5 with ABS edging.

Si possono accostare:

- Letti START L 86,3/96,3
- Giroletto imbottito KANT L 98
- Turche
- Giroletti metallici L 88/98

Can be placed next to:

- START bed W 86,3/96,3
- KANT padded bed frame W 98
- Ottomans
- Metal bed frames W 88/98

Nel momento in cui si ordina una scrivania è possibile dotarla di accessori integrati per i quali è necessaria l'esecuzione di fori sui piani (foratura a nostra cura).

Possono essere scelti uno o più accessori:
When ordering a desk, it can be fitted with built-in accessories requiring holes to be drilled in the tops (drilled by us).
One or more accessories can be chosen:



Ricarica wireless + presa USB
Wireless charging + USB socket



Copriforo per passacavi
Cover for wire leads

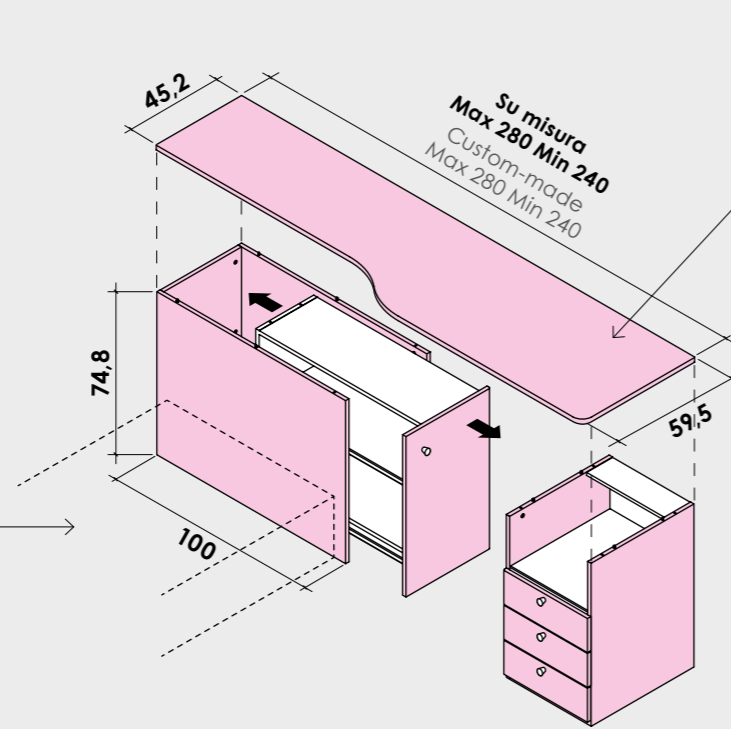
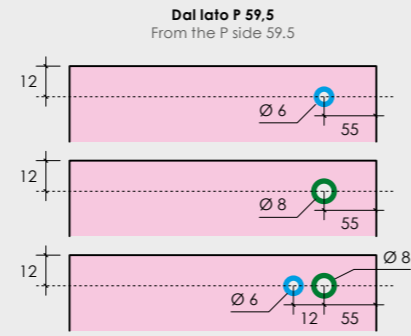

Scrivanie ALPA - H 77,6

ALPA desks - Ht 77.6

Piano ALPA Sp 2,5 bordato in ABS
Fianchi in pannello Sp 1,8
ALPA top Th 2.5 with ABS edging
Side panels Th 1.8

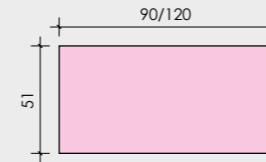

- Pannello retro sagomato Sp 2,5 bordato in ABS.
- Completo di kit di fissaggio a muro o a pannello.
- Shaped back panel Th 2.5 with ABS edging.
- Including wall or panel-fixing kit.

Nel momento in cui si ordina una scrivania è possibile dotarla di accessori integrati per i quali è necessaria l'esecuzione di fori sui piani (foratura a nostra cura).

Possono essere scelti uno o più accessori:
When ordering a desk, it can be fitted with built-in accessories requiring holes to be drilled in the tops (drilled by us).
One or more accessories can be chosen:



Ricarica wireless + presa USB
Wireless charging + USB socket



Copriforo per passacavi
Cover for wire leads

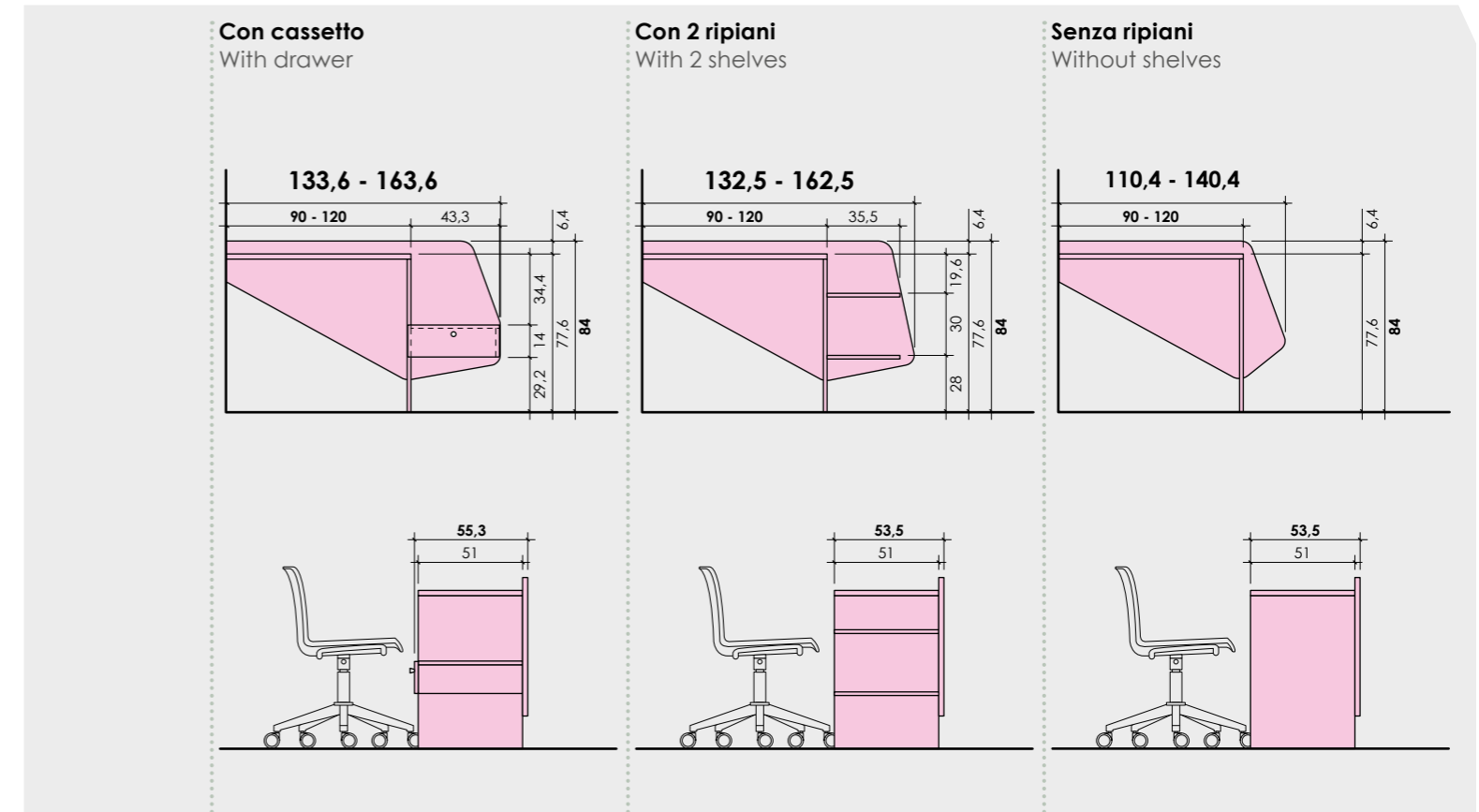
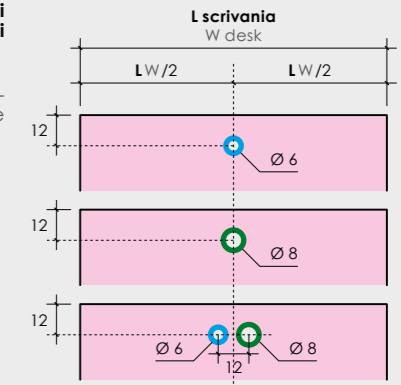

Piano scrivania
Desk top

L W 90

Specificare Sx o Dx (disegno Sx)
Specify L or R (R drawing)

COD.	VF15.90F	VF15.91N	VF15.92U
A			
B			

Piano scrivania
Desk top

L W 120

Specificare Sx o Dx (disegno Sx)
Specify L or R (R drawing)

COD.	VF15.93A	VF15.94G	VF15.95P
A			
B			

Sovrapprezzi per rallentatore chiusura:
Surcharge for closing retainer:

CASSETTO
DRAWER

pag. 42
pag. 171

Posizionamento pomelli e maniglie
Knobs and handles position
Accessori per scrivanie
Desks accessories

	L su misura (min 240 - max 280) W custom-made (min 240 - max 280)	L su misura (min 220 - max 280) W custom-made (min 220 - max 280)	L su misura (min 220 - max 280) W custom-made (min 220 - max 280)
COD.	VF15.71B	VF15.72H	VF15.73Q
A			
B			

Specificare Sx o Dx (disegno Sx)
Specify L or R (L drawing)

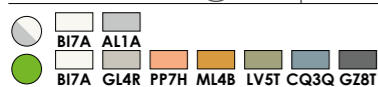

Scrivania sospesa FLOW - L 120 P 47,3

FLOW suspended desk - W 120 Dpt 47.3

Pannello retro Sp 1,8 bordato in ABS.
Completo di kit di fissaggio a muro.
I cassetti sono dotati di guide tipo "Quadro" rallentate o push-pull di serie. Possono montare tutte le maniglie della collezione ad eccezione di TALL e BAND.

Rear panel Th 1.8 edged in ABS.
Complete with wall fixing kit.
The drawers are equipped with slowed down or push-pull "Quadro" type guides as standard. They can fit all the handles in the collection except for TALL and BAND.

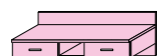
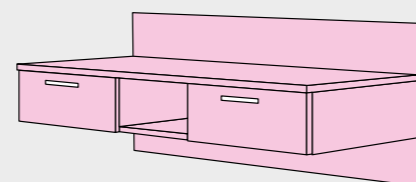
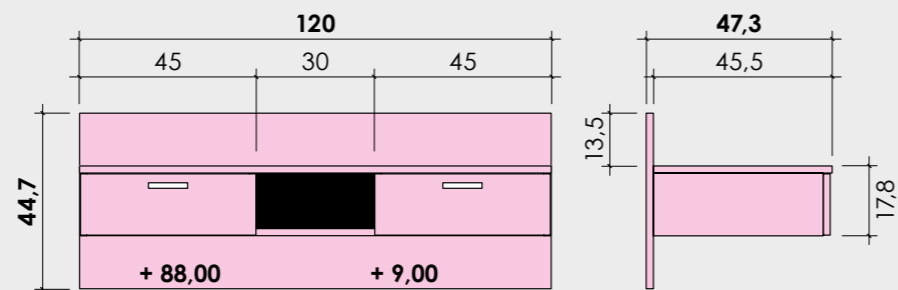

COD. VF15.96V

A
B

Accessori per scrivanie

Desks accessories

Portatastiera estraibile in metallo

Pull-out metal keyboard holder

L W 59
P Dpt 29,5
H Ht 6

Per un corretto utilizzo, verificare la sagoma del piano su cui viene fissato
For a proper employment, check top shape on which it will be fixed

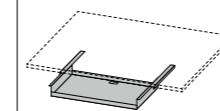

COD. VF34.45P

Porta PC con ruote

PC holder with castors

L W 29
P Dpt 50
H Ht 39

Posizionabile all'esterno o all'interno delle scrivanie
Can be placed outside or inside desks

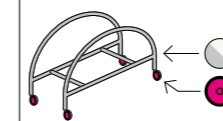

COD. VF34.46V

Porta PC sospeso regolabile

Adjustable suspended PC holder

L W 16/22
P Dpt 26,5
H Ht 58

Con attacco sottopiano
With under-top attachment

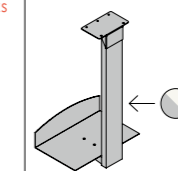

COD. VF34.47B

Barra antiriflessione

Anti-reflection bar

L W 105
P Dpt 8

Per rinforzare piani scrivania maggiori di 120 cm
To reinforce tops larger than 120 cm



COD. VF34.48H

presa USB da incasso

Wireless charging + USB socket

Ø 6

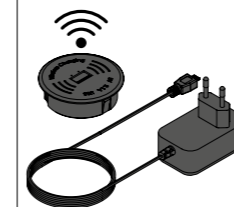

COD. VF34.49Q

Cover for wire leads

Ø 8

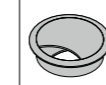

COD. VF34.50M

Gamba di sostegno ONE

ONE supporting leg

L W 2,5
P Dpt 55,5
H Ht 75,1

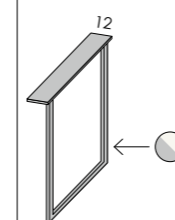

COD. VF34.51T

Gamba di sostegno THREE

THREE supporting leg

Ø 2,8
P Dpt 56,5
H Ht 75,1

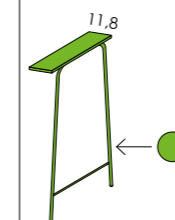

COD. VF34.52Z

Gamba di sostegno TWO

TWO supporting leg

L W 5
P Dpt 5
H Ht 75,1

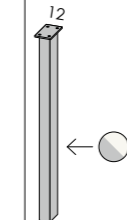

COD. VF34.53F

Cassettiere

Chest of drawers

L W 45
P Dpt 45,8
H Ht 51,2

Ruote con freno
Casters with brakes



COD. VF34.54N

L W 45
P Dpt 45,8
H Ht 51,2

Ruote senza freno
Casters without brakes



COD. VF34.55U

Sovrapprezzi per rallentatore chiusura:
Surcharge for closing retainer:

+ 13,00 CASSETTO
DRAWER

pag. 42

Posizionamento pomelli e maniglie
Knobs and handles position

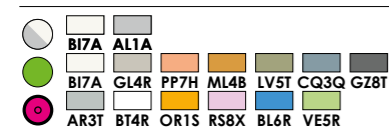

Mensole - Sp 2,5 P 26

Shelves - Th 2.5 Dpt 26

	L W 45	L W 60	L W 90	L W 118	L W 120	L W 135	L W 178
COD. Senza reggimensola Without shelf holder	VF16.10S	VF16.30C	VF16.11Y	VF16.12E	VF16.13M	VF16.18U	VF16.19A
COD. Con reggimensola With shelf holders	VF16.14T ²	VF16.31K ²	VF16.15Z ²	VF16.16F ²	VF16.17N ²	VF16.22L ²	VF16.23S ²
A scomparsa Integrated							
LAMPO							
KUB							

	L W 180	L W 208	L W 223	L W 238	Su misura Custom-made L W min 30 - max 360	
COD. Senza reggimensola Without shelf holder	VF16.20X	VF16.21D	VF16.26M	VF16.32R	VF16.27T	
COD. Con reggimensola With shelf holders	VF16.24Y ²	VF16.25E ⁴	VF16.28Z ⁴	VF16.33X ⁴	VF16.29F ²	
A scomparsa Integrated						
LAMPO						
KUB						
						<div style="border: 1px dashed red; padding: 5px;"> <p>Per mensole su misura superiori a L 180 vengono forniti 2 reggimensola aggiuntivi For custom-made shelves over W 180, 2 additional shelf holders are supplied</p> <p> + 10,00</p> <p> + 18,00</p> <p> + 20,00</p> </div>

CARICO MASSIMO CONSIGLIATO (al netto delle mensole)
MAXIMUM RECOMMENDED LOAD (shelves weight excluded)
30 Kg per ogni coppia di reggimensola
for every pair of shelf holders

NB. Il carico si intende uniformemente distribuito sulla mensola. Tra 2 reggimensola ci deve essere una distanza non superiore a 135 cm
NOTE. Load shall be evenly distributed on the shelf. The maximum distance between 2 shelf holders shall be 135 cm

Accessori Accessories	Coppie di reggimensola Pair of shelf holders		
	A scomparsa Integrated	LAMPO L W 3,5 P Dpt 8	KUB L W 3 P Dpt 4
		 Apertura: Opening: min 1,5 max 3,5	 Apertura: Opening: min 2 max 4
COD.	VF32.27G	VF32.28P	VF32.29V

2 4 **Numero di reggimensola in dotazione**
Number of shelf holders supplied

Provisti di ferramenta per fissaggio a pannello.
In caso di fissaggio a muro la scelta del tipo di tassello da utilizzare dovrà essere fatta dal montatore sulla base delle caratteristiche della parete.
Complete with hardware for fixing to panel.
In case of wall fixing the choice of hardware depends on the wall conditions and should be made by the assembler.

AIR

Lamiera Sp 0,2.
Applicabili a muro. Ferramenta inclusa.
È possibile creare una composizione accostando più elementi.

Sheet metal Th 0,2.
Can be applied to wall. Hardware included. A composition can be created by lining up several elements.

Specificare Sx o Dx (disegno Dx)
Specify L or R (R drawing)

CARICO MASSIMO CONSIGLIATO
MAXIMUM RECOMMENDED LOAD
10 Kg a muro
on wall

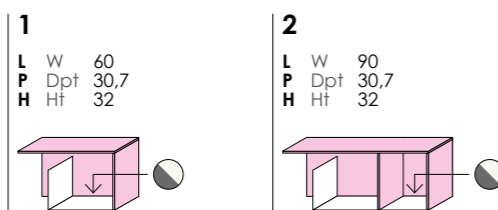

COD.	VF16.51V	VF16.52B
	(A)	(B)

NET

Applicabili a muro e pannello.
Ferramenta inclusa. È possibile creare una composizione accostando e ruotando più elementi.

Can be applied to wall or panel.
Hardware included. A composition can be created by rotating and lining up several elements.

CARICO MASSIMO CONSIGLIATO
MAXIMUM RECOMMENDED LOAD
30 Kg a muro
on wall **10 Kg** a pannello
on panel

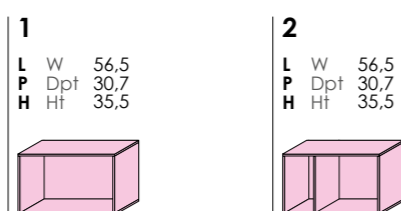

COD.	VF16.41Q	VF16.42W
	(A)	(B)

PILL

Applicabile a muro. Ferramenta inclusa.
Apertura anta tramite presa laterale, il vano portaoggetti lateralmente rimane a vista.

Can be applied to wall. Hardware included.
Door opening via side grip, the storage compartment remains visible on the side.

Specificare cerniera Sx o Dx (disegno Sx)
Specify hinge L or R (L drawing)

CARICO MASSIMO CONSIGLIATO
MAXIMUM RECOMMENDED LOAD
10 Kg a muro
on wall

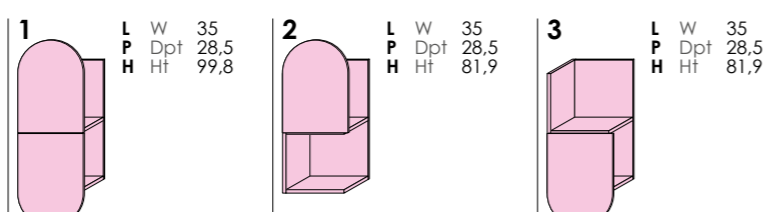

COD.	VF16.54Q	VF16.58R	VF16.59X
	(A)	(B)	

ROBIN

Applicabile a muro, a pannello o in appoggio. Ferramenta inclusa. È possibile creare una composizione accostando, sovrapponendo e ruotando più elementi.

Applicable to wall, to panel or laid.
Hardware included. It is possible to create a composition by combining, superpositioning and rotating more elements.

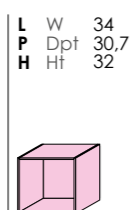

CARICO MASSIMO CONSIGLIATO
MAXIMUM RECOMMENDED LOAD
30 Kg a muro
on wall **10 Kg** a pannello
on panel

COD.	VF16.40H
	(A)
	(B)

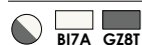

TIXE

Lamiera Sp 0,2, schiena in pannello Sp 1,8. Applicabili a muro. Ferramenta inclusa. È possibile creare una composizione accostando più elementi.

Sheet metal Th 0,2, back panel Th 1,8.
Can be applied to wall. Hardware included. A composition can be created by lining up several elements.

CARICO MASSIMO CONSIGLIATO
MAXIMUM RECOMMENDED LOAD
15 Kg

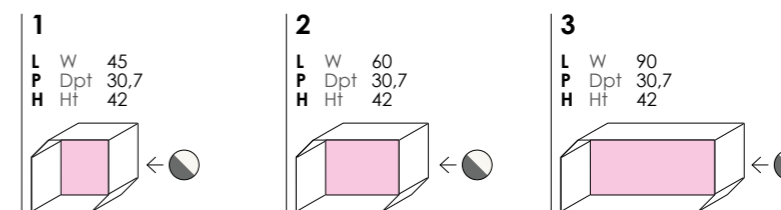

COD.	VF16.47D	VF16.48L	VF16.49S
	(A)	(B)	

WEB

Applicabili a muro e pannello.
Ferramenta inclusa. È possibile creare una composizione accostando e ruotando più elementi.

Can be applied to wall or panel.
Hardware included. A composition can be created by rotating and lining up several elements.

CARICO MASSIMO CONSIGLIATO
MAXIMUM RECOMMENDED LOAD
15 Kg

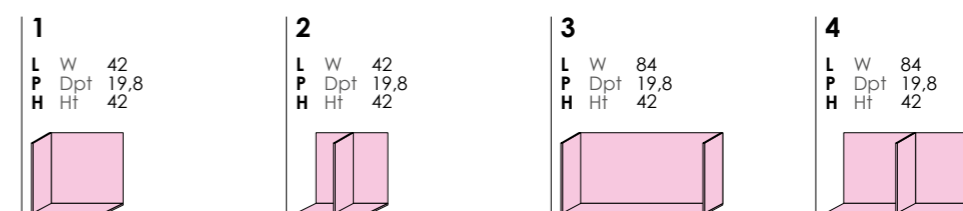

COD.	VF16.43C	VF16.44K	VF16.45R	VF16.46X
	(A)	(B)		

Pannelli attrezzati STRIP - P 20

STRIP equipped panels - Dpt 20

- Elementi predisposti per le configurazioni presentate a listino
- In dotazione ferramenta per fissaggio a muro
- Mensole P 18; lamiera Sp 0,2

- Units designed for use in the configurations shown in the catalogue
- Supplied hardware for wall mounting
- Shelves Dpt 18; Sheet metal Th 0,2

	STRIP A	STRIP B	STRIP C	STRIP D
	L W 60 H Ht 32	L W 90 H Ht 32	L W 60 H Ht 32	L W 90 H Ht 32
			Specificare Sx o Dx (disegno Dx) Specify L or R (R drawing)	Specificare Sx o Dx (disegno Dx) Specify L or R (R drawing)
Mensola e pannello retro sempre dello stesso colore. Shelf and back panel always in the same color.				
COD.	VF17.06E	VF17.07M	VF17.08T	VF17.09Z
	(A)			
	(B)			

Pannelli attrezzati PILL - P 28,5

PILL equipped panels - Dpt 28.5

- In dotazione ferramenta per fissaggio a muro
- Mensole P 26

- Supplied hardware for wall mounting
- Shelves Dpt 26

	PILL A	PILL B	PILL C	PILL D	PILL E
	L W 45 H Ht 32	L W 45 H Ht 64	L W 45 H Ht 84,5	L W 45 H Ht 84,5	L W 45 H Ht 84,5
				Specchio Ø 30 Mirror Ø 30	Specchio Ø 30 Mirror Ø 30
					3 appendibili SEED Ø 5,2 3 SEED Ø 5.2 clothes hook
COD.	VF17.01X	VF17.02D	VF17.03L	VF17.04S	VF17.05Y
	(A)				
	(B)				

Appendibili
Clothes hook

BOLLINO

Ø 10
P Dpt 4

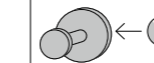

COD.	VF32.61Q
------	----------

Pannelli attrezzati BING - P 28,5

BING equipped panels - Dpt 28.5

- In dotazione ferramenta per fissaggio a muro
- Mensole P 26

- Supplied hardware for wall mounting
- Shelves Dpt 26

	BING A	BING B	BING C
	L W 53,8 H Ht 64	L W 59 H Ht 41,6	L W 103,7 H Ht 41,6
COD.	VF16.72N	VF16.73U	VF16.74A
	(A)		
	(B)		

Pannelli attrezzati DROP - P 20,5

DROP equipped panels - Dpt 20.5

- In dotazione ferramenta per fissaggio a muro
- Mensole P 18

- Supplied hardware for wall mounting
- Shelves Dpt 18

	DROP A	DROP B
	L W 71 H Ht 111,7	L W 111,7 H Ht 71
COD.	VF16.75G	VF16.76P
	(A)	
	(B)	

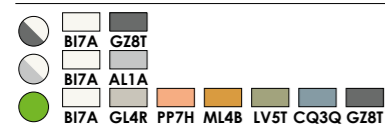



Pannelli attrezzati EXPILON - P 28,5

EXPILON equipped panels - Dpt 28.5

- In dotazione ferramenta per fissaggio a muro
- Mensole P 26

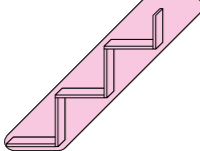
- Supplied hardware for wall mounting
- Shelves Dpt 26

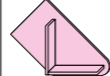
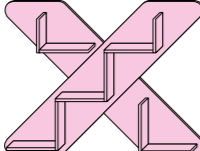
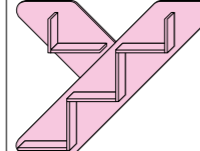
Componenti		EXPILON A	EXPILON B	EXPILON C
Components		L W 129,3 H Ht 100,2	L W 64,6 H Ht 50,1	L W 64,6 H Ht 50,1
				
COD.		VF16.77V	VF16.78B	VF16.79H
	(A)			
	(B)			
Composizioni		EXPILON X	EXPILON Y	
Compositions		L W 129,3 H Ht 100,2	L W 129,3 H Ht 100,2	
				
COD.		VF16.80E	VF16.81M	
	(A)			
	(B)			

I componenti possono essere colorati a discrezione del cliente
I componenti possono essere colorati a discrezione del cliente

Esempio
Example

Miele ML4B

Bianco opaco B17A

Papaya PP7H

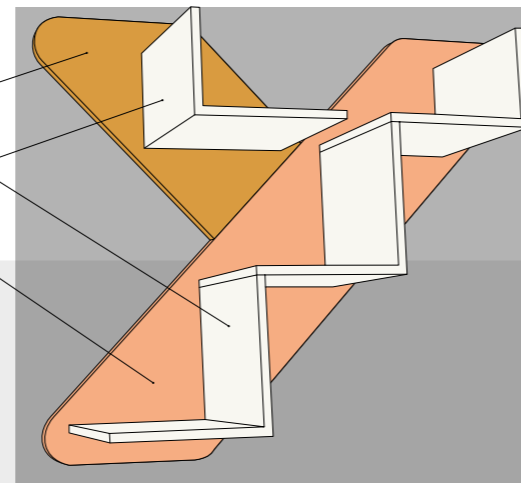

Misure d'ingombro

Overall dimensions

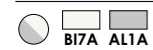
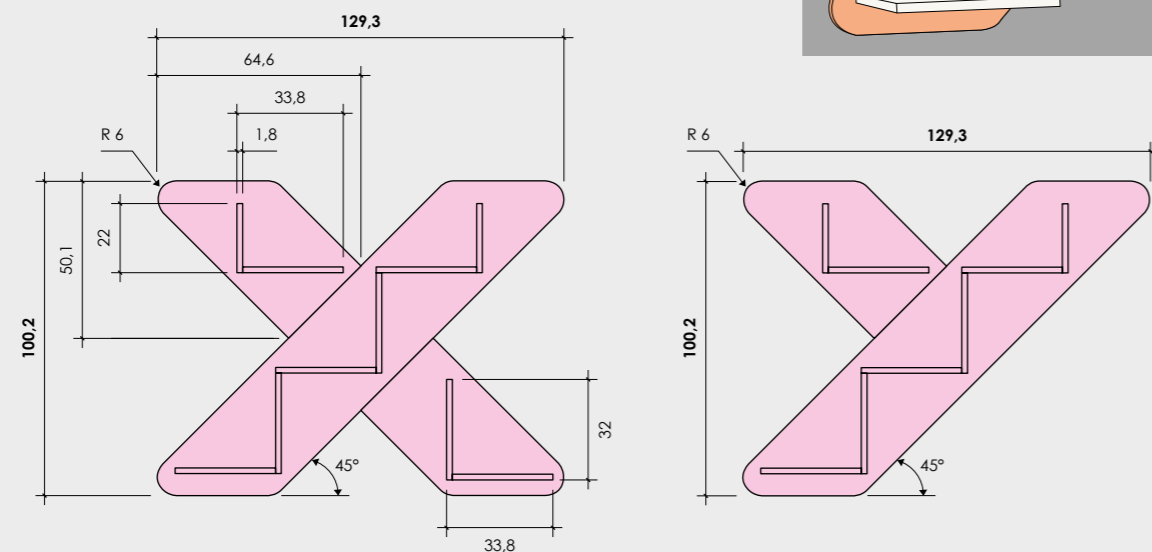

Pannelli attrezzati porta TV - H 90

Equipped panels for TV - Ht 90

- Pannello frontale Sp 1,8. Mensole Sp 2,5.
- Completati di attaccaglie per fissaggio a muro dotate di antisganciamento.
- Kit illuminazione opzionale costituito da: una strip LED, alimentatore e interruttore.

- Front panel Th 1,8. Shelves Th 2,5.
- Including wall-fastening hangers with anti-release mechanism.
- Optional lighting kit consisting of: one LED strip, power supply and switch.

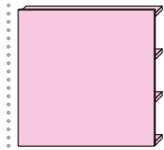
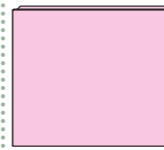
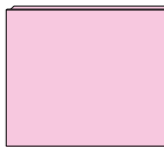
		L W 90	L W 135	L W 150
				
P Dpt		27,8		
COD.		VF16.98N	VF16.99U	VF17.00R
SENZA illuminazione WITHOUT lighting	(A)			
	(B)			
CON illuminazione WITH lighting	(A)			
	(B)			

Misure d'ingombro

Overall dimensions

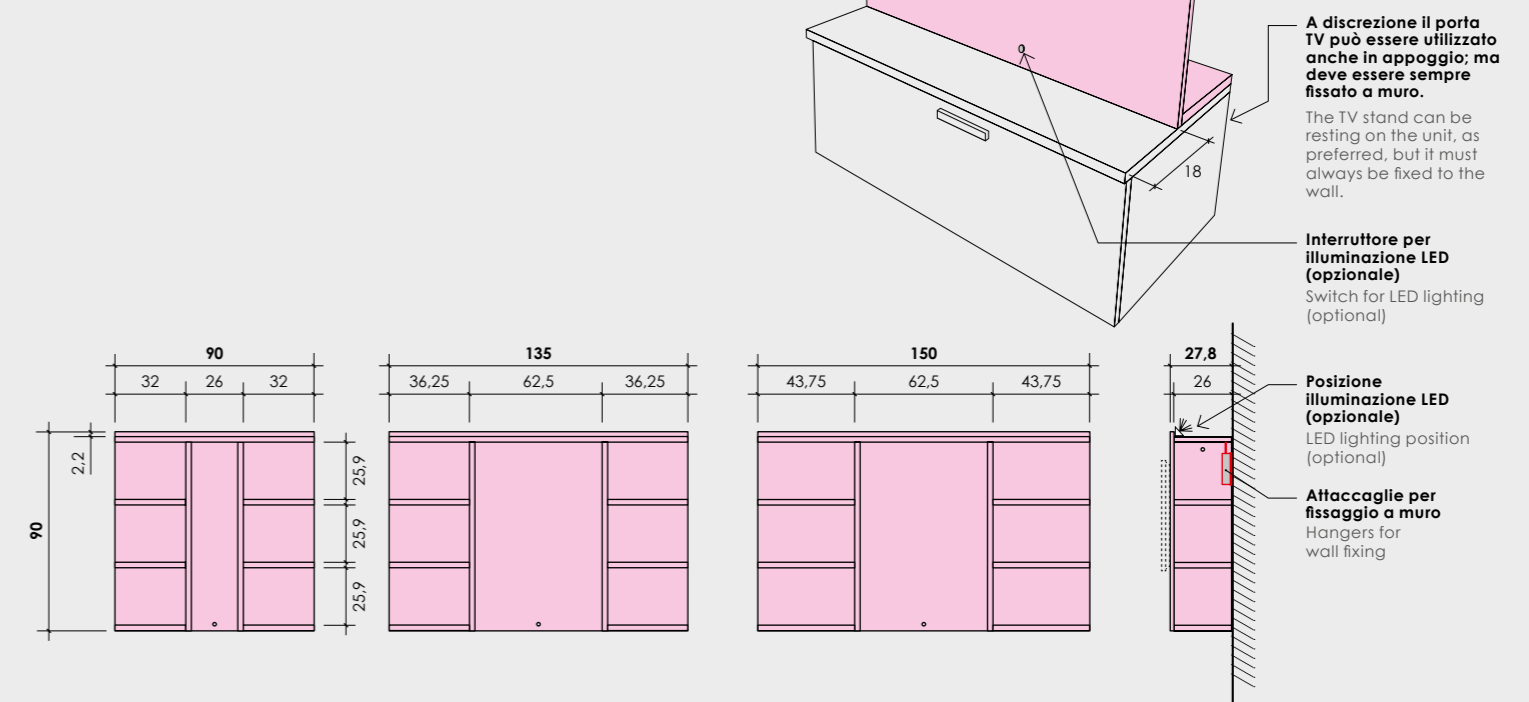

A discrezione il porta TV può essere utilizzato anche in appoggio; ma deve essere sempre fissato a muro.
The TV stand can be resting on the unit, as preferred, but it must always be fixed to the wall.

Interruttore per illuminazione LED (opzionale)
Switch for LED lighting (optional)

Posizione illuminazione LED (opzionale)
LED lighting position (optional)

Attaccaglie per fissaggio a muro
Hangers for wall fixing

Pannelli attrezzati STRANGE - H 90

STRANGE equipped panels - Ht 90

• Elementi predisposti per le configurazioni presentate a listino
 • In dotazione ferramenta per fissaggio a muro

• Units designed for use in the configurations shown in the catalogue
 • Supplied hardware for wall mounting

	L W 90	L W 120	L W 135	Su misura Custom L W min 45 max 180
STRANGE Semplice senza fori Plain without drillings				
P Dpt 1,85				
COD.	VF16.85N	VF16.88G	VF16.91S	VF16.94M
STRANGE A Con mensole lineari P 26 With linear shelves Dpt 26				
P Dpt 28,3				
COD.	VF16.86U	VF16.89P	VF16.92Y	VF16.95T
STRANGE B Con mensola lineare, mensola a "L" e cubolotto ROBIN With linear shelf, "L" shelves and ROBIN cube				
P Dpt 33				
COD.	VF16.87A	VF16.90L	VF16.93E	

Accessori Accessories	Mensola lineare su misura Custom-made linear shelf	Coppia mensola a "L" Pair of "L" shelves	ROBIN cubolotto cube	Specchio Mirror	BOLLINO Mirror	PLUS	SEED Ø 5,2 3 appendiabiti 3 clothes hook
	L W min 45 max 180 P Dpt 26	L W 56 P Dpt 26 H Ht 15	L W 34 P Dpt 30,7 H Ht 32	Ø 30	Ø 4 P Dpt 10	L W 4,3 P Dpt 3 H Ht 6,5	Ø 5,2 P Dpt 2,4
COD.	VF16.96Z	VF16.97F	VF16.40H	VF34.39K	VF32.61Q	VF32.62W	VF35.63R

Scrivanie, mensole e cubolotti
Desks, shelves and cubes

Facciate Fronts
VOLO

Finiture GRUPPO 1
GROUP 1 finishes

Finiture GRUPPO 2
GROUP 2 finishes







Rovere white*

 (A) ☆ Rovere white RW3Q	 (A) ☆ Noce brina NB5T	 (A) Bianco opaco B17A	 (A) Grigio Dorian GL4R	 (B) ☆ Cemento artico CA7A	 (B) ☆ Rovere gesso RG9L
 (B) ☆ Royal oak RS4B	 (B) ☆ Rovere cognac RC3Q	 (B) Grigio titanio GZ8T			
 (B) Papaya PP7H	 (B) Miele ML4B	 (B) Oliva LV5T	 (B) Cadaques CQ3Q		

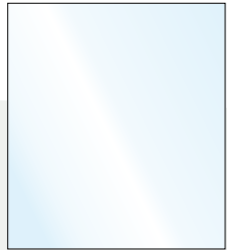
Vetri Glass

Ante Doors
WINDOW

Colori telaio
Frame colours

 Trasparente TR9M	 Trasparente fumé FT8P	 Stop sol ST6P	 Specchio SP7L	 Alluminio AL1A	 Titan grey TG7H
--	---	---	--	--	---

Rovere white* Finitura unica per tutti i componenti in pannello presenti a listino non evidenziati con il colore Finiture GRUPPO 1 e/o Finiture GRUPPO 2.
Unique finish for all the panel components shown in the pricelist not highlighted with the color finishes GROUP 1 and/or finishes GROUP 2.

- (A) Finiture in fascia di prezzo A
Finishes in price range A
- (B) Finiture in fascia di prezzo B
Finishes in price range B
- (☆) Finiture con effetto materico
Finishes with textured effect

LIBRERIA INFINITY
INFINITY BOOKSHELF

Libreria INFINITY - Informazioni tecniche INFINITY bookshelf - Technical information	pag. 184
Libreria INFINITY - Ante e cassetti INFINITY bookshelf - Doors and drawers	pag. 188
Libreria INFINITY - H 195,3 P 33,3 INFINITY bookshelf - Ht 195.3 Dpt 33.3	pag. 190
Libreria INFINITY - H 227,3 P 33,3 INFINITY bookshelf - Ht 227.3 Dpt 33.3	pag. 192
Libreria INFINITY - H 259,3 P 33,3 INFINITY bookshelf - Ht 259.3 Dpt 33.3	pag. 194
Libreria INFINITY - Schiene, ripiani e accessori INFINITY bookshelf - Backs, shelves and accessories	pag. 196
Libreria INFINITY angolo intero - P 33,3 Full corner INFINITY bookshelf - Dpt 33.3	pag. 198
Libreria INFINITY terminale - P 33,3 End-bookshelf INFINITY - Dpt 33.3	pag. 199



COMPONENTI

Tutti i componenti sono retro finiti.
I fianchi hanno foratura personalizzata con passo per ripiani a 32 cm; su richiesta è possibile il posizionamento a 16 cm.
Il posizionamento della ferramenta è personalizzato in base alla posizione dei componenti.
La schiena, in luce rispetto ai fianchi, può essere inserita all'interno della struttura frontalmente (in caso di libreria a muro) o dal retro (in caso di libreria a centro stanza).
Le ante sono dotate di cerniere decelerate.
Le ante vasistas/ribalta sono dotate di cerniere a scomparsa e braccio di tipo meccanico modello snodo.
Le ante possono essere dotate di apertura PUSH-PULL.
I Cassetti sono dotati di guide metalliche di tipo "QUADRO" a chiusura rallentata regolabili in altezza con interno in finitura CHARM.
I ripiani in legno e vetro, per libreria con schiena, possono essere dotati di illuminazione.
Ripiani in vetro temperato secondo la norma UNI EN 12150-1.

NOTE DI SICUREZZA

Tutte le librerie vengono sempre fornite di piastrino per l'ancoraggio a muro ma non di tasselli fisher per il fissaggio del piastrino a parete. La scelta del tipo di tassello da utilizzare dovrà essere fatta dal montatore sulla base delle caratteristiche della parete.
Ancoraggio obbligatorio a parete o a soffitto per garantire la stabilità.

COMPONENTS

The back of each component is properly finished.
Side panels have customized holes for shelves every 32 cm; upon request holes can be done every 16 cm.
The hardware is placed in a personalized fashion according to the position of the components.
The back panel, in between the side panels, can be assembled frontally (if it's for wall bookcase) or from the back (if it's for a centrally-positioned bookcase).
The doors are equipped with hinges decelerate.
The vasistas/folding doors are provided with concealed hinges and joint lid stay arm.
The doors are also available with PUSH-PULL.
Drawers are provided with "QUADRO" metal runners which have adjustable height and soft close system with interior CHARM finish.
An illumination system can be assembled on wood or glass shelves of bookcases with back panel.
The tempered glass shelves comply with the UNI EN 12150-1 standard.

SAFETY NOTES

Each bookcase is provided with a metal plate for wall fixing, but not with the hardware for the wall positioning of the plate. The choice of hardware depends on the wall conditions and should be made by the assembler.
Fixing to wall or to ceiling is required to guarantee stability.

LIBRERIA A TERRA
SELF STANDING BOOKCASE

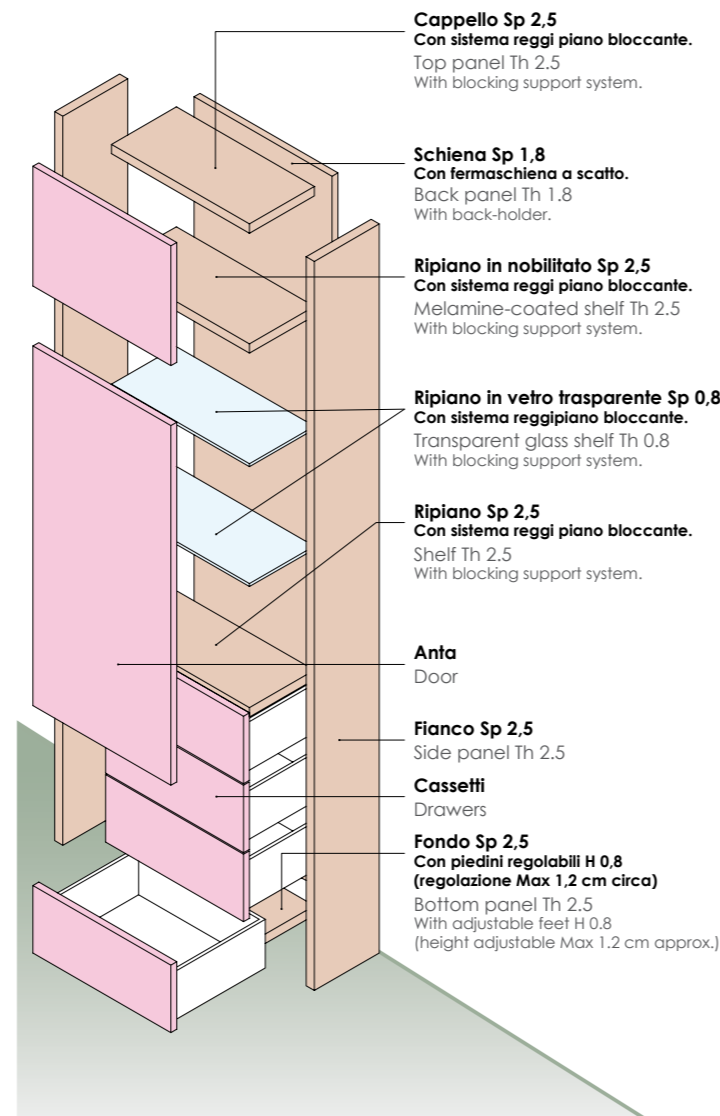

LIBRERIA CON SCHIENA
Ancoraggio obbligatorio a parete o a soffitto per garantire la stabilità.
Le librerie con schiena proposte a listino prevedono lo schienale intero a tutta altezza.

BOOKCASE WITH BACK PANEL
Fixing to wall or to ceiling is required to guarantee stability.
The bookcases with back panel proposed in the price list include a all in one and full height back panel.

LIBRERIA PASSANTE
Ancoraggio obbligatorio a parete o a soffitto per garantire la stabilità.
Sono attrezzabili con ante battenti, cassette, ribalte e vasistas.
Vani a giorno bifrontali.
Vani con frontali accessibili solo da un lato.
Sono composte da ripiani P 33,3; in corrispondenza di vani chiusi con schiena da ripiani P 30,8.

PASS-THROUGH BOOKCASE
Fixing to wall or to ceiling is required to guarantee stability.
They can be equipped with hinged doors, drawers, bottom-hinged doors and top-hinged doors.
Two-sided open compartments.
Compartments with only one accessible side.
They are composed of Dpt 33.3 shelves; where the compartment is closed with back panel, the shelves assembled are Dpt 30.8.

LIBRERIA BIFACCIALE
Ancoraggio obbligatorio a parete o a soffitto per garantire la stabilità.
Sono composte interamente da ripiani P 33,3.
Sono attrezzabili con ante battenti, cassette, ribalte e vasistas.
Vani a giorno bifrontali.
Vani con frontali accessibili da entrambi i lati, ECCETTO vani attrezzati con cassette accessibili solo da un lato e sempre dotati di schiena.
Non disponibile su Angoli e Terminali.

TWO-SIDED BOOKCASE
Fixing to wall or to ceiling is required to guarantee stability.
They are entirely composed of Dpt 33.3 shelves.
They can be equipped with hinged doors, drawers, bottom-hinged doors and top-hinged doors.
Two-sided open compartments.
Both side accessible compartments, EXCEPT for those which have drawers which are accessible only from one side and have always back panel.
Not available on Corner units and End units.

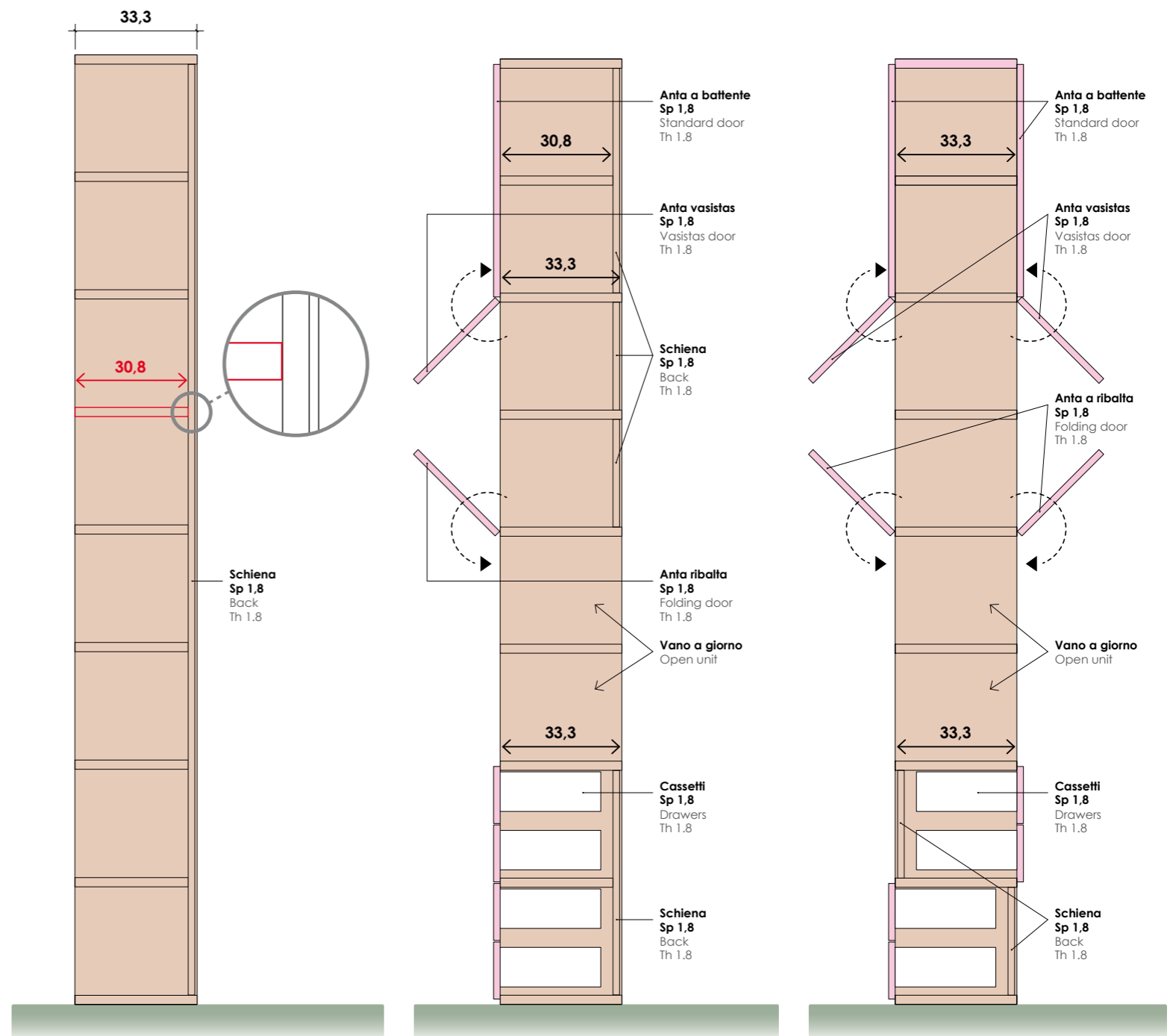

ANGOLO INTERO
FULL CORNER

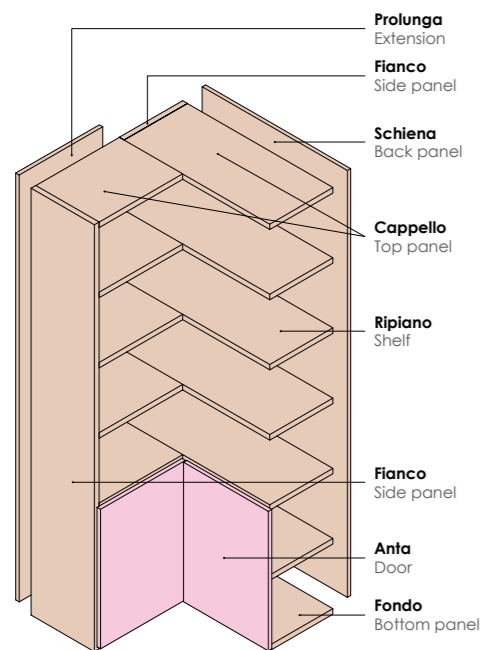

LIBRERIA TERMINALE CURVO
CURVED BOOKCASE END UNIT

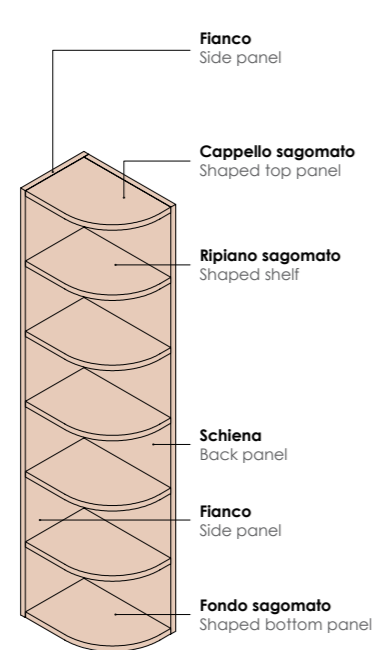

Libreria INFINITY - Informazioni tecniche

INFINITY bookshelf - Technical information

LARGHEZZE E PROFONDITÀ

WIDTH AND DEPTH

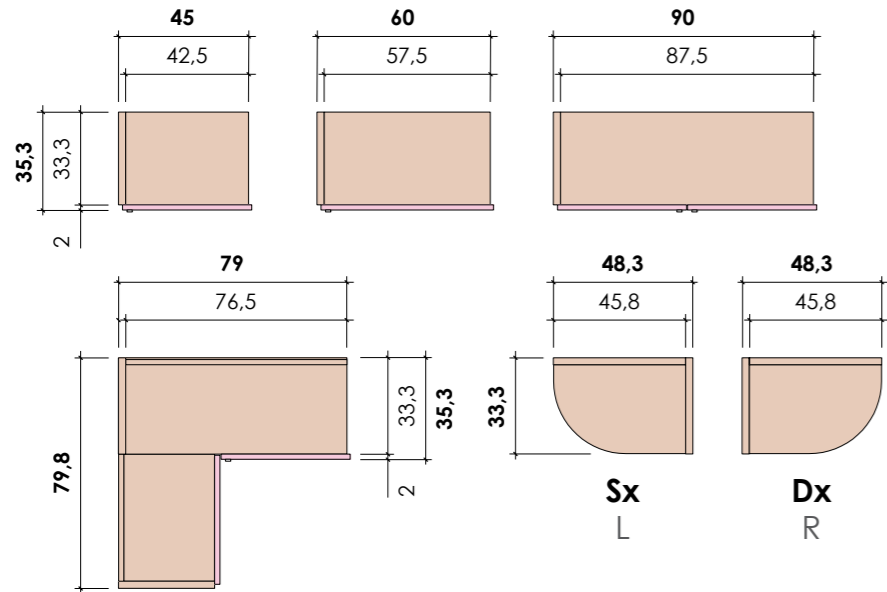

ALTEZZE
Il posizionamento standard del ripiano è a passo 32 cm. A richiesta c'è la possibilità di inserire un ripiano a passo 16 cm. Altezze comprensive di piedino regolabile H 0,8 cm.

HEIGHT
The standard distance between each shelf is 32 cm. Upon request, shelves can be positioned every 16 cm. Ht 0.8 cm adjustable foot included in heights.

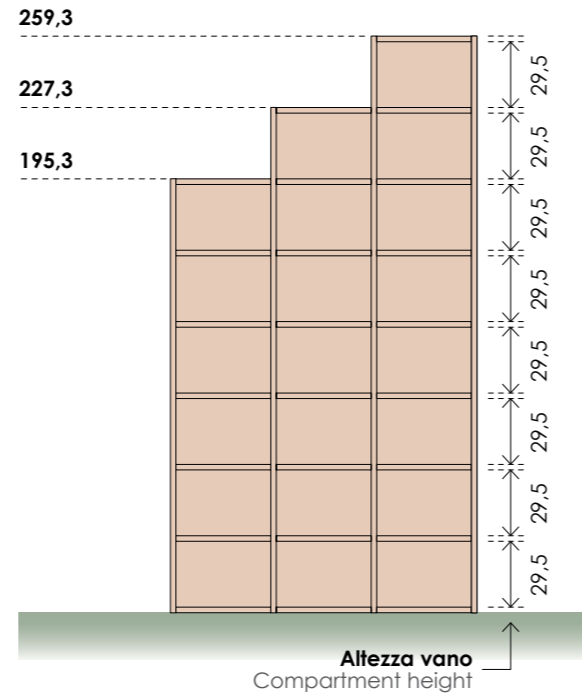

ALCUNI ESEMPI DI COMPONIBILITÀ

SOME COMPOSITION EXAMPLES

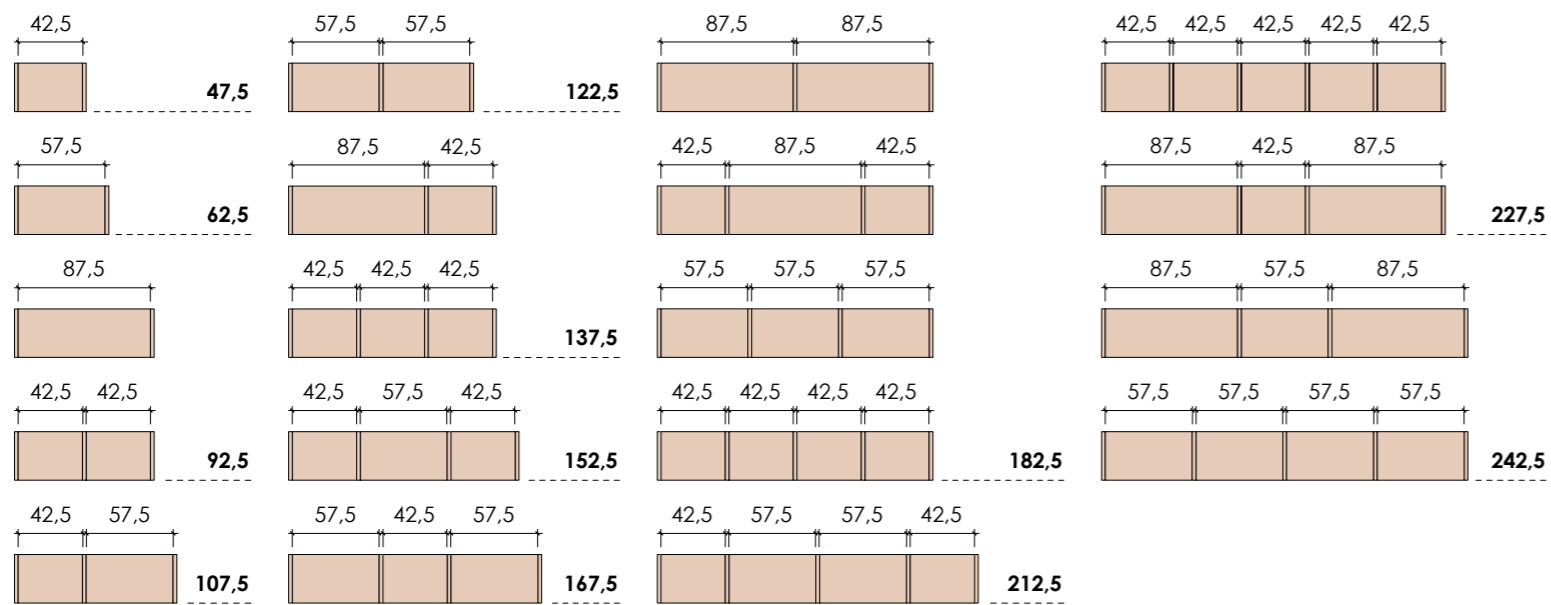

DISTANZE MINIME PER IL MONTAGGIO

MINIMUM DISTANCES FOR ASSEMBLING

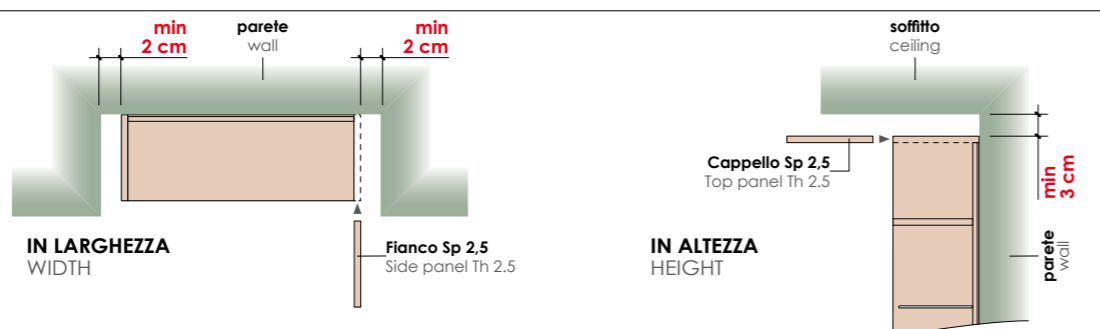

RIPIANO IN LEGNO CON LUCE LED
L'illuminazione per ripiano in legno è costituita da una strip led (60 led/mt) posizionata nella parte retro del ripiano. Lunga come tutto il ripiano, permette di illuminare riflettendosi nella schiena sia il vano superiore che inferiore. La tipologia di illuminazione è naturale. Si consiglia l'utilizzo di tale tipologia di illuminazione in presenza di schiena. Viene fornito un alimentatore (con sovrapprezzo) in grado di sostenere da 1 a 6 ripiani L 45/60 o da 1 a 4 ripiani L 90.

WOODEN SHELF WITH LED LIGHT
The wooden shelf light is a led strip (60 led/m) assembled on the back side of the shelf. The strip shares the same length with the shelf and by reflecting the light on the back panel, it enlightens the compartments above and below. The colour tone of the LED strip is natural. We recommend using this type of light system when there is a back panel. We provide a power pack (with a surcharge) able to support from 1 to 6 shelves W 45/60 or from 1 to 4 shelves W 90.

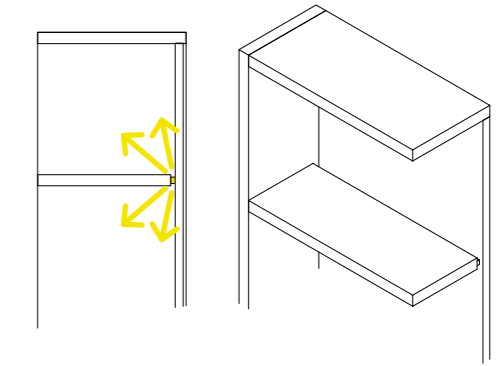

RIPIANO IN VETRO TRASPARENTE CON LUCE LED
L'illuminazione per ripiano in vetro è costituita da un profilo in PVC con strip led (60 led/mt), posizionata nella parte retro del ripiano. Lunga come tutto il ripiano, permette di illuminare riflettendosi nella schiena sia il vano superiore che inferiore, ma anche frontale. La tipologia di illuminazione è naturale. Si consiglia l'utilizzo di tale tipologia di illuminazione in presenza di schiena. Viene fornito un alimentatore (con sovrapprezzo) in grado di sostenere da 1 a 6 ripiani L 45/60 o da 1 a 4 ripiani L 90.

TRANSPARENT GLASS SHELF WITH LED LIGHT
The glass shelf light system consists in a PVC profile with led strip (60 led/m) assembled on the back side of the shelf. The strip shares the same length with the shelf, it gives a front lighting and by reflecting the light on the back panel, it enlightens the compartments above and below. The colour tone of the LED strip is natural. We recommend using this type of light system when there is a back panel. We provide a power pack (with a surcharge) able to support from 1 to 6 shelves W 45/60 or from 1 to 4 shelves W 90.

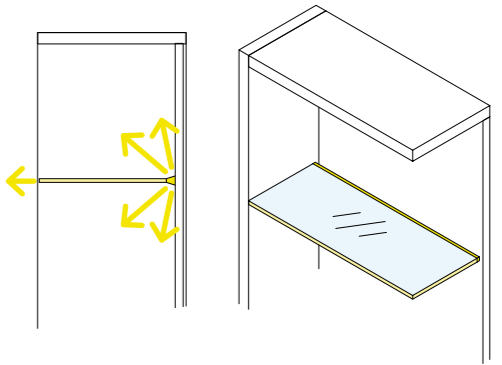

FARETTO LED
La tipologia di illuminazione è naturale. Viene fornito un alimentatore (con sovrapprezzo) in grado di sostenere da 1 a 6 faretti. Si consiglia l'utilizzo di tale tipologia di illuminazione nel cappello. I faretti vengono posizionati nel modo sotto indicato (cablaggi a vista).

LED SPOTLIGHT
The colour tone of the LED strip is natural. We provide a power pack (with a surcharge) able to support from 1 to 6 spotlights. We recommend using this type of light system only on top panel. Spotlights are assembled as showed below (wiring in sight).

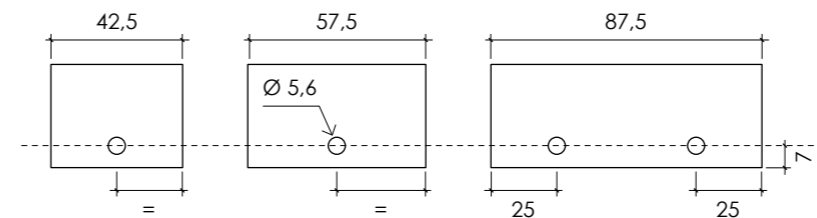
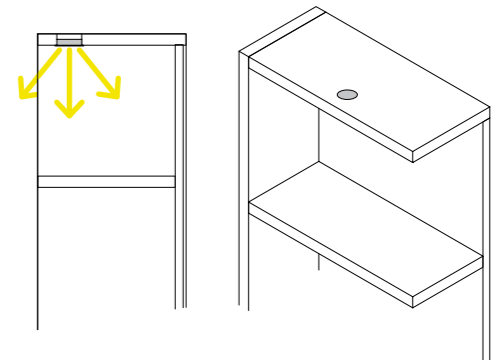

INTERRUTTORE

L'accensione di tali ripiani può avvenire in 2 modi:
ON/OFF SWITCH

The on/off switching of the shelves can be done in 2 different ways:

1) Collegando l'alimentatore alla spina di casa, usando come accensione l'interruttore di casa.

By connecting the power supply unit to your home electrical system and using your own standard power switch.

2) Ordinando un interruttore wireless presente nel listino.

Tale interruttore permette l'accensione o spegnimento di tutti i punti luce presenti nella libreria, contemporaneamente, sino ad un massimo di 30 ripiani o faretti.

By ordering our wireless on/off switch from catalogue. This switch allows you to turn on or off all the LED lights in the bookcase, up to a maximum of 30 shelves or spotlights.

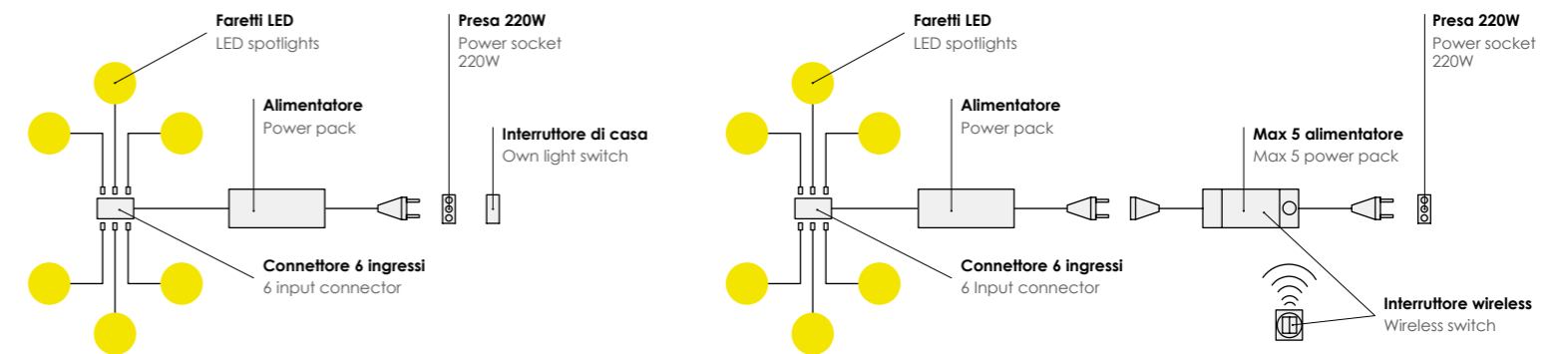

Libreria INFINITY - Ante e cassetti

INFINITY bookshelf - Doors and drawers

- Sono dotate di cerniere decelerate.
- Le ante VOLO sono disponibili anche con apertura push-pull.
- Su richiesta le ante VOLO possono essere fornite senza maniglia e senza fori maniglia.

- The doors are equipped with hinges decelerate.
- The VOLO doors are also available with push-pull opening.
- Upon request, the VOLO doors can be supplied without a handle and without handle holes.

- Le ante vasistas e ribalta sono dotate di cerniere a scomparsa e braccio di tipo meccanico modello snodo.
- Le ante VOLO vasistas e ribalta sono disponibili anche con apertura PUSH-PULL.

- The vasistas/folding doors are provided with concealed hinges and joint lid stay arm.
- The VOLO vasistas/folding doors can be supplied with PUSH-PULL system.

L W	Ante Doors							
	H Ht 32	H Ht 64	H Ht 96	H Ht 128	H Ht 160	H Ht 192	H Ht 224	H Ht 256
45	2 cerniere 2 hinges	2 cerniere 2 hinges	2 cerniere 2 hinges	3 cerniere 3 hinges	3 cerniere 3 hinges	4 cerniere 4 hinges	4 cerniere 4 hinges	4 cerniere 4 hinges
COD.	VF08.60Z	VF08.61F	VF08.62N	VF08.63U	VF08.64A	VF08.65G	VF08.66P	VF08.67V
VOLO	(A)	(A)	(A)	(A)	(A)	(A)	(A)	(A)
WINDOW	(B)	(B)	(B)	(B)	(B)	(B)	(B)	(B)

L W	Ante Doors							
	H Ht 32	H Ht 64	H Ht 96	H Ht 128	H Ht 160	H Ht 192	H Ht 224	H Ht 256
60	2 cerniere 2 hinges	2 cerniere 2 hinges	2 cerniere 2 hinges	3 cerniere 3 hinges	3 cerniere 3 hinges	4 cerniere 4 hinges	4 cerniere 4 hinges	4 cerniere 4 hinges
COD.	VF08.68B	VF08.69H	VF08.70E	VF08.71M	VF08.72T	VF08.73Z	VF08.74F	VF08.75N
VOLO	(A)	(A)	(A)	(A)	(A)	(A)	(A)	(A)
WINDOW	(B)	(B)	(B)	(B)	(B)	(B)	(B)	(B)

L W	Coppia ante Pair of doors							
	H Ht 32	H Ht 64	H Ht 96	H Ht 128	H Ht 160	H Ht 192	H Ht 224	H Ht 256
90	4 cerniere 4 hinges	4 cerniere 4 hinges	4 cerniere 4 hinges	6 cerniere 6 hinges	6 cerniere 6 hinges	8 cerniere 8 hinges	8 cerniere 8 hinges	8 cerniere 8 hinges
COD.	VF10.26L	VF10.27S	VF10.28Y	VF10.29E	VF10.30B	VF10.31H	VF10.32Q	VF10.33W
VOLO	(A)	(A)	(A)	(A)	(A)	(A)	(A)	(A)
WINDOW	(B)	(B)	(B)	(B)	(B)	(B)	(B)	(B)

L W	Coppia ante Pair of doors							
	H Ht 32	H Ht 64	H Ht 96	H Ht 128	H Ht 160	H Ht 192	H Ht 224	H Ht 256
per Angoli interi for Corner wardrobes	4 cerniere 4 hinges	4 cerniere 4 hinges	4 cerniere 4 hinges	6 cerniere 6 hinges	6 cerniere 6 hinges	8 cerniere 8 hinges	8 cerniere 8 hinges	8 cerniere 8 hinges
COD.	VF08.76U	VF08.77A	VF08.78G	VF08.79P	VF08.80L	VF08.81S	VF08.82Y	VF08.83E
VOLO	(A)	(A)	(A)	(A)	(A)	(A)	(A)	(A)
WINDOW	(B)	(B)	(B)	(B)	(B)	(B)	(B)	(B)

L W	Ante vasistas e a ribalta H 32 Vasistas and folding doors Ht 32	
	45	
COD.	VF08.84M	VF08.88N
VOLO	(A)	(A)
WINDOW	(B)	(B)

L W	Ante vasistas e a ribalta H 32 Vasistas and folding doors Ht 32	
	60	
COD.	VF08.85T	VF08.89U
VOLO	(A)	(A)
WINDOW	(B)	(B)

L W	Ante vasistas e a ribalta H 32 Vasistas and folding doors Ht 32	
	90	
COD.	VF08.86Z	VF08.90R
VOLO	(A)	(A)
WINDOW	(B)	(B)

L W	Ante vasistas e a ribalta H 32 Vasistas and folding doors Ht 32	
	120	
COD.	VF08.87F	VF08.91X
VOLO	(A)	(A)
WINDOW	(B)	(B)

- I cassetti sono dotati di guide metalliche tipo "QUADRO" rallentate regolabili in altezza.

- Drawers are provided with "Quadro" slowed down metal runners which have adjustable height.

L W	Cassetti H 16 - P 29,8 Drawers Ht 16 - Dpt 29.8		
	45		
COD.	VF08.92D	VF08.93L	VF08.94S
VOLO	(A)	(A)	(A)
WINDOW	(B)	(B)	(B)
60			
COD.	VF08.95Y	VF08.96E	VF08.97M
VOLO	(A)	(A)	(A)
WINDOW	(B)	(B)	(B)
90			
COD.	VF08.98T	VF08.99Z	VF09.00W
VOLO	(A)	(A)	(A)
WINDOW	(B)	(B)	(B)

ATTENZIONE:
Per un corretto funzionamento del sistema a ribalta o vasistas seguire le regole sotto riportate.

WARNING:
For a correct operation of folding and vasistas system, follow the instructions below.

Le ante ribalta/vasistas L 90 e 120 si possono montare anche su 2 elementi affiancati esclusivamente come da esempio.
Folding/vasistas doors W 90 and 120 can be mounted also on 2 juxtaposed elements exclusively as indicated in the example.

Libreria INFINITY - H 195,3 P 33,3
 INFINITY bookshelf - Ht 195.3 Dpt 33.3

CON SCHIENA
 WITH BACK PANEL

L
W **45**

Specificare
cerniera Sx o Dx
Specify hinge
L or R

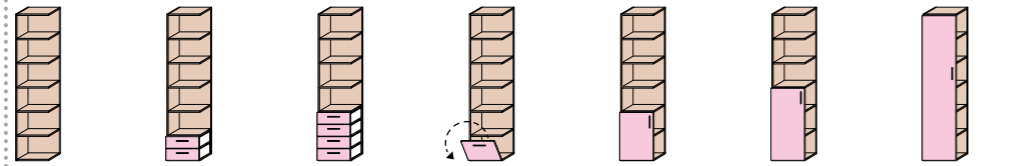

COD. VF08.00S VF09.04X VF09.05D VF09.06L VF09.07S VF09.08Y VF09.09E

VOLO A B

WINDOW A B

L
W **60**

Specificare
cerniera Sx o Dx
Specify hinge
L or R

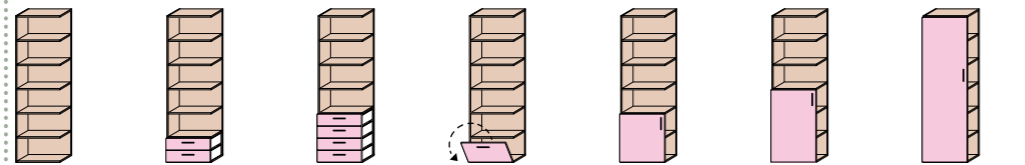

COD. VF08.03M VF09.10B VF09.11H VF09.12Q VF09.13W VF09.14C VF09.15K

VOLO A B

WINDOW A B

L
W **90**

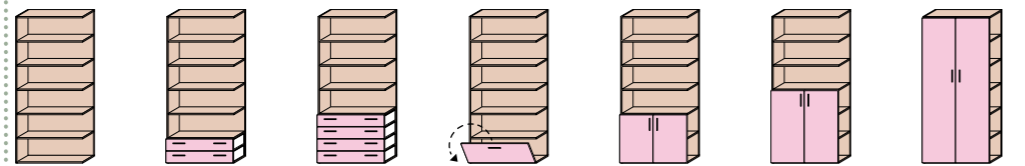

COD. VF08.06F VF09.26W VF09.27C VF09.28K VF09.29R VF09.30N VF09.31U

VOLO A B

WINDOW A B

PASSANTI
 SEE-THROUGH

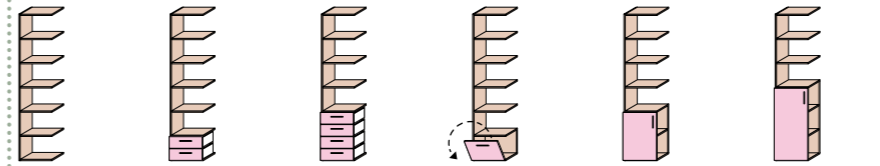

COD. VF08.09A VF09.16R VF09.17X VF09.18D VF09.19L VF09.20G

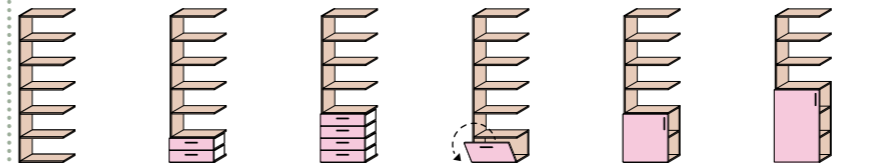

COD. VF08.12L VF09.21P VF09.22V VF09.23B VF09.24H VF09.25Q

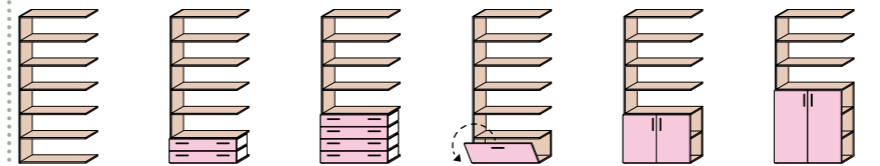

COD. VF08.15E VF09.32A VF09.33G VF09.34P VF09.35V VF09.36B

Fianco
 (piede H 0.8 escluso)
 Side panel
 (Ht 0.8 foot not included)

H Ht 195,3
 P Dpt 33,3
 Sp Th 2,5

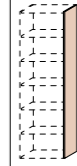

COD. VF08.42B

! Consigliamo l'utilizzo del nostro software grafico. È indispensabile graficare e/o inviare un disegno della composizione completa. Per la corretta personalizzazione dei fianchi si raccomanda di vestire i moduli librerie con ante, cassetti, ripiani e schiene. Tutte le composizioni devono essere completate con fianco finale.

We recommend using our graphic software. It is necessary to plot and/or send a drawing of the whole composition. For a correct customization of the side panels, we recommend you to integrate the modular bookcase units with doors, drawers, shelves and back panels. Each composition must be completed with end side panel.

pag. 42
 pag. 188
 pag. 196

Posizionamento pomelli e maniglie
 Knobs and handles position
Ante e cassetti
 Doors and drawers
Schiene e accessori
 Backs and accessories

CON SCHIENA
 WITH BACK PANEL

L
W **45**

Specificare
cerniera Sx o Dx
Specify hinge
L or R

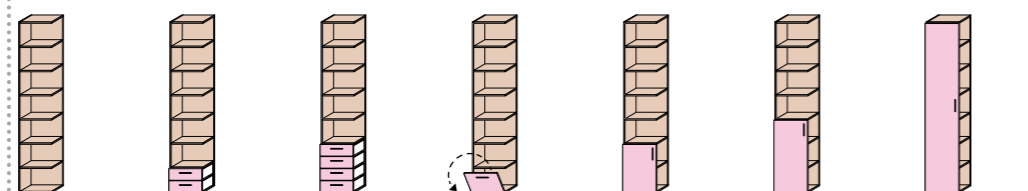

COD. VF08.01Y VF09.37H VF09.38Q VF09.39W VF09.40T VF09.41Z VF09.42F

VOLO (A) (B)
 WINDOW (A) (B)

L
W **60**

Specificare
cerniera Sx o Dx
Specify hinge
L or R

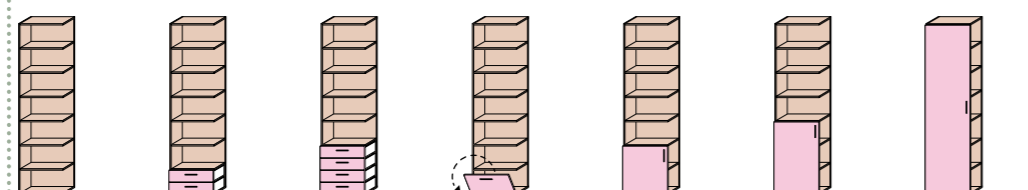

COD. VF08.04T VF09.43N VF09.44U VF09.45A VF09.46G VF09.47P VF09.48V

VOLO (A) (B)
 WINDOW (A) (B)

L
W **90**

Specificare
cerniera Sx o Dx
Specify hinge
L or R

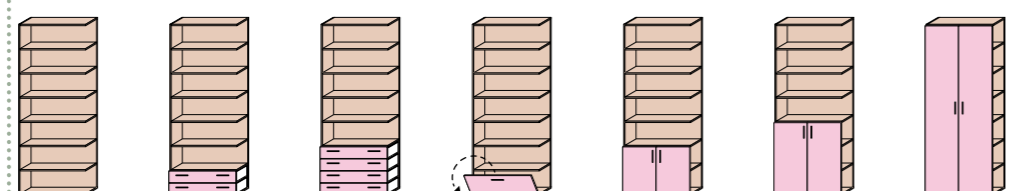

COD. VF08.07N VF09.59G VF09.60D VF09.61L VF09.62S VF09.63Y VF09.64E

VOLO (A) (B)
 WINDOW (A) (B)

PASSANTI
 SEE-THROUGH

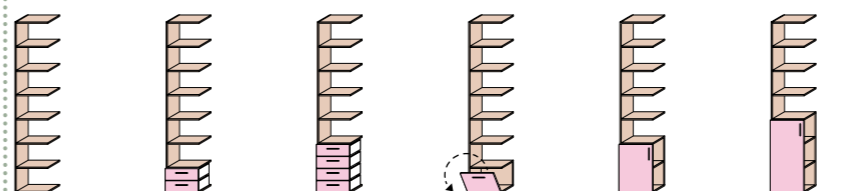

COD. VF08.10X VF09.49B VF09.50Y VF09.51E VF09.52M VF09.53T

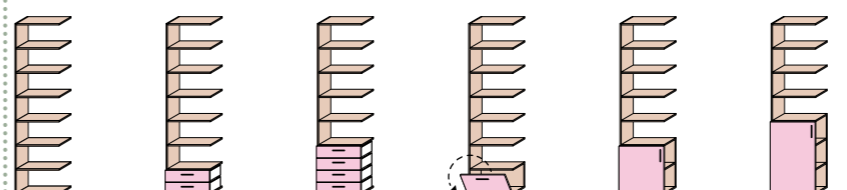

COD. VF08.13S VF09.54Z VF09.55F VF09.56N VF09.57U VF09.58A

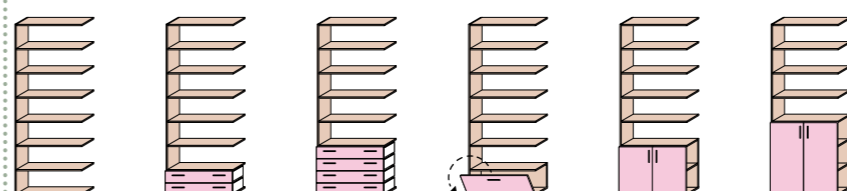

COD. VF08.16M VF09.65M VF09.66T VF09.67Z VF09.68F VF09.69N

Fianco
 (piede H 0.8 escluso)
 Side panel
 (Ht 0.8 foot not included)

H Ht 227,3
 P Dpt 33,3
 Sp Th 2,5

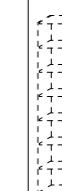

COD. VF08.43H

! Consigliamo l'utilizzo del nostro software grafico. È indispensabile graficare e/o inviare un disegno della composizione completa. Per la corretta personalizzazione dei fianchi si raccomanda di vestire i moduli librerie con ante, cassetti, ripiani e schiene. Tutte le composizioni devono essere completate con fianco finale.

We recommend using our graphic software. It is necessary to plot and/or send a drawing of the whole composition. For a correct customization of the side panels, we recommend you to integrate the modular bookcase units with doors, drawers, shelves and back panels. Each composition must be completed with end side panel.

pag. 42
 pag. 188
 pag. 196

Posizionamento pomelli e maniglie
 Knobs and handles position
Ante e cassetti
 Doors and drawers
Schiene e accessori
 Backs and accessories

CON SCHIENA
 WITH BACK PANEL

L
W **45**

Specificare
cerniera Sx o Dx
Specify hinge
L or R

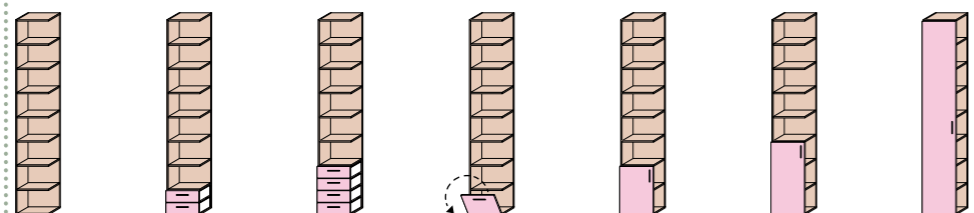

COD. VF08.02E VF09.70K VF09.71R VF09.72X VF09.73D VF09.74L VF09.75S

VOLO (A) (B)
 WINDOW (A) (B)

L
W **60**

Specificare
cerniera Sx o Dx
Specify hinge
L or R

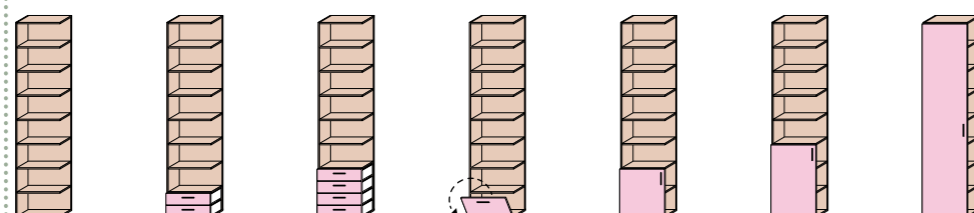

COD. VF08.05Z VF09.76Y VF09.77E VF09.78M VF09.79T VF09.80Q VF09.81W

VOLO (A) (B)
 WINDOW (A) (B)

L
W **90**

Specificare
cerniera Sx o Dx
Specify hinge
L or R

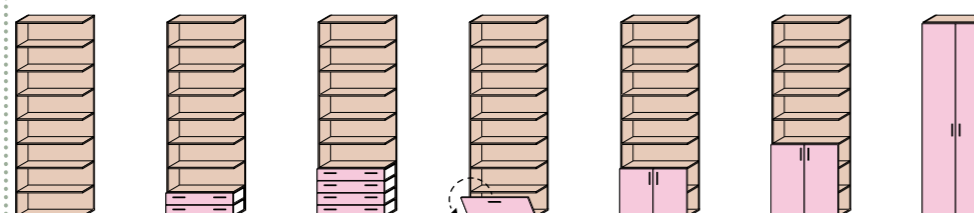

COD. VF08.08U VF09.92H VF09.93Q VF09.94W VF09.95C VF09.96K VF09.97R

VOLO (A) (B)
 WINDOW (A) (B)

PASSANTI
 SEE-THROUGH

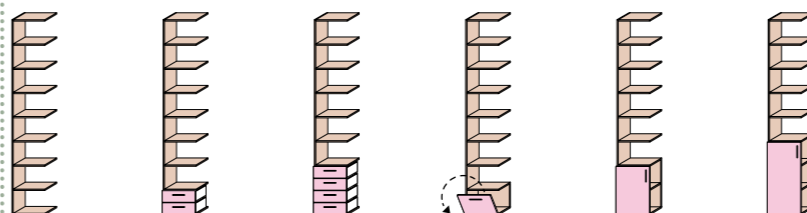

COD. VF08.11D VF09.82C VF09.83K VF09.84R VF09.85X VF09.86D

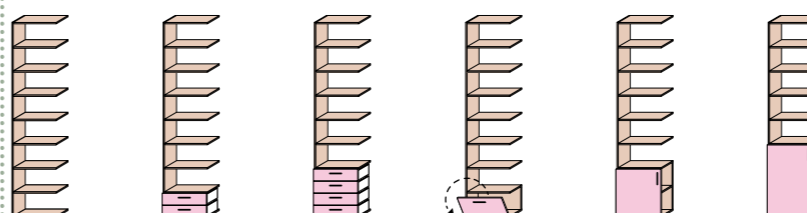

COD. VF08.14Y VF09.87L VF09.88S VF09.89Y VF09.90V VF09.91B

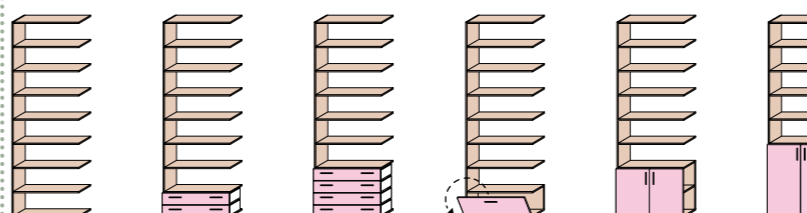

COD. VF08.17T VF09.98X VF09.99D VF10.00L VF10.01S VF10.02Y

Fianco
 (piede H 0.8 escluso)
 Side panel
 (Ht 0.8 foot not included)

H Ht 259,3
 P Dpt 33,3
 Sp Th 2,5

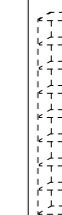

COD. VF08.44Q

⚠ **Consigliamo l'utilizzo del nostro software grafico.** È indispensabile graficare e/o inviare un disegno della composizione completa. Per la corretta personalizzazione dei fianchi si raccomanda di vestire i moduli librerie con ante, cassetti, ripiani e schiene. Tutte le composizioni devono essere completate con fianco finale.

We recommend using our graphic software. It is necessary to plot and/or send a drawing of the whole composition. For a correct customization of the side panels, we recommend you to integrate the modular bookcase units with doors, drawers, shelves and back panels. Each composition must be completed with end side panel.

pag. 42
 pag. 188
 pag. 196

Posizionamento pomelli e maniglie
 Knobs and handles position
Ante e cassetti
 Doors and drawers
Schiene e accessori
 Backs and accessories

Libreria INFINITY - Schiene, ripiani e accessori

INFINITY bookshelf - Backs, shelves and accessories

Schiene Sp 1,8 Backs Th 1.8

L
W **42,5**

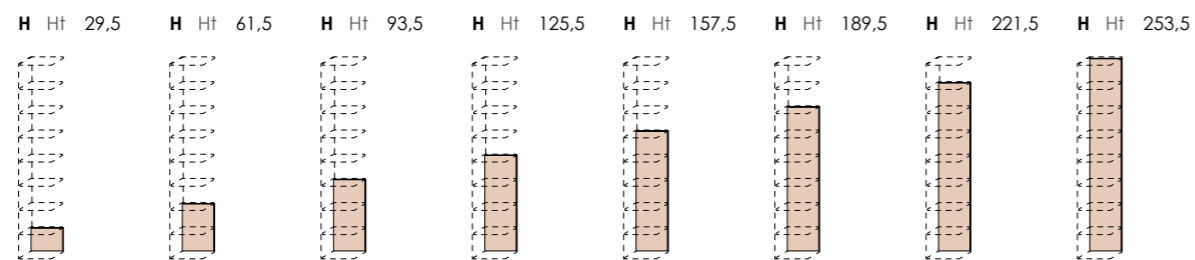

COD.	VF08.18Z	VF08.19F	VF08.20C	VF08.21K	VF08.22R	VF08.23X	VF08.24D	VF08.25L
VOLO	<div style="display: flex; justify-content: space-around;"> (A) (B) </div>							

Schiene Sp 1,8 Backs Th 1.8

L
W **57,5**

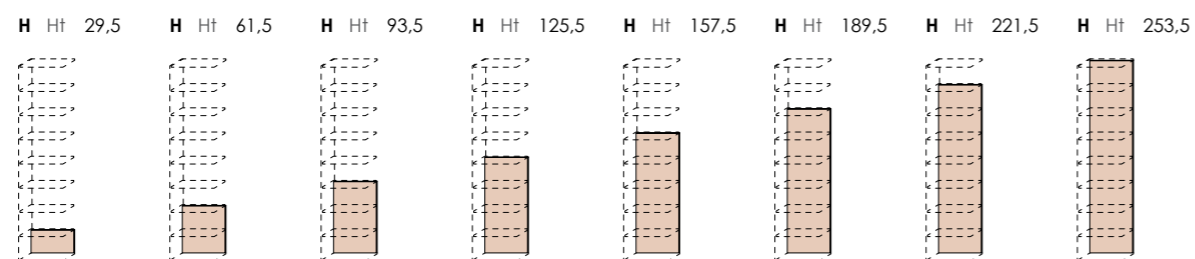

COD.	VF08.26S	VF08.27Y	VF08.28E	VF08.29M	VF08.30H	VF08.31Q	VF08.32W	VF08.33C
VOLO	<div style="display: flex; justify-content: space-around;"> (A) (B) </div>							

Schiene Sp 1,8 Backs Th 1.8

L
W **87,5**

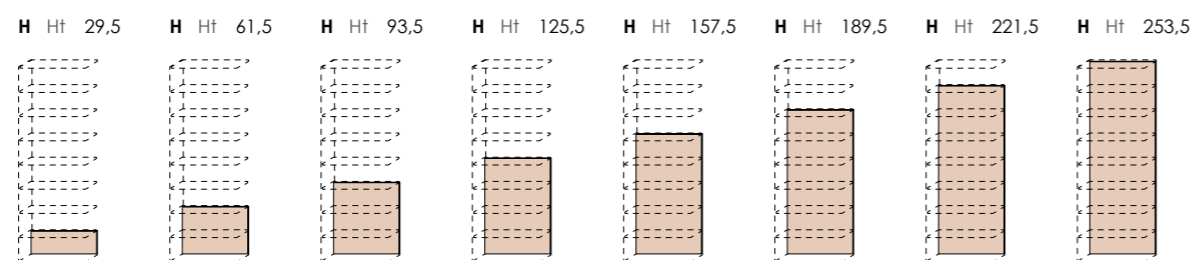

COD.	VF08.34K	VF08.35R	VF08.36X	VF08.37D	VF08.38L	VF08.39S	VF08.40P	VF08.41V
VOLO	<div style="display: flex; justify-content: space-around;"> (A) (B) </div>							

Ripiani mobili in nobilitato Melamine-coated movable shelves

Sp
Th **2,5**

L W 42,5	COD.	P Dpt 30,8 Per Librerie con schiena For Bookcases with back	P Dpt 33,3 Per Librerie passanti For See-through bookcases	P Dpt 29,8 Per Librerie con schiena For Bookcases with back
L W 57,5	COD.	VF08.45W	VF08.46C	VF08.47K
		<div style="display: flex; justify-content: space-around;">(A)(B)</div>	<div style="display: flex; justify-content: space-around;">(A)(B)</div>	<div style="display: flex; justify-content: space-around;">(A)(B)</div>
L W 87,5	COD.	VF08.50U	VF08.51A	VF08.52G
		<div style="display: flex; justify-content: space-around;">(A)(B)</div>	<div style="display: flex; justify-content: space-around;">(A)(B)</div>	<div style="display: flex; justify-content: space-around;">(A)(B)</div>
L W 87,5	COD.	VF08.55B	VF08.56H	VF08.57Q
		<div style="display: flex; justify-content: space-around;">(A)(B)</div>	<div style="display: flex; justify-content: space-around;">(A)(B)</div>	<div style="display: flex; justify-content: space-around;">(A)(B)</div>

Ripiani mobili in vetro trasparente Transparent glass movable shelves

Sp
Th **0,8**

L W 42,5	COD.	P Dpt 28,5 Per Librerie con schiena e librerie passanti For Bookcases with back and see-through bookcases	P Dpt 28,5 Per Librerie con schiena For Bookcases with back
L W 57,5	COD.	VF08.48R	VF08.49X
		<div style="display: flex; justify-content: space-around;">(A)(B)</div>	<div style="display: flex; justify-content: space-around;">(A)(B)</div>
L W 87,5	COD.	VF08.53P	VF08.54V
		<div style="display: flex; justify-content: space-around;">(A)(B)</div>	<div style="display: flex; justify-content: space-around;">(A)(B)</div>
L W 87,5	COD.	VF08.58W	VF08.59C
		<div style="display: flex; justify-content: space-around;">(A)(B)</div>	<div style="display: flex; justify-content: space-around;">(A)(B)</div>

Faretto LED Ø 6,5
LED spotlights Ø 6.5
12 volt 1,7 watt.

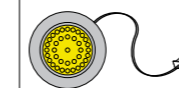

COD. **VF32.55L**

Interruttore wireless
Wireless switch
Per illuminazione LED.
(utilizzabile sia per ripiani
che per faretto).
For LED lighting (usable for
shelves and spotlight).

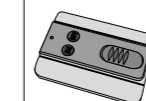

COD. **VF32.57Y**

Sovrapprezzi:
Surcharge:

per alimentatore illuminazione led (vedi pagine iniziali per specifiche).
for LED lighting power pack (refer to initial pages for specifications).

! Consigliamo l'utilizzo del nostro software grafico. È indispensabile graficare e/o inviare un disegno della composizione completa. Per la corretta personalizzazione dei fianchi si raccomanda di vestire i moduli librerie con ante, cassetti, ripiani e schiene. Tutte le composizioni devono essere completate con fianco finale.

We recommend using our graphic software. It is necessary to plot and/or send a drawing of the whole composition. For a correct customization of the side panels, we recommend you to integrate the modular bookcase units with doors, drawers, shelves and back panels. Each composition must be completed with end side panel.

Libreria INFINITY angolo intero - P 33,3

Full corner INFINITY bookshelf - Dpt 33.3

CON SCHIENA WITH BACK PANEL

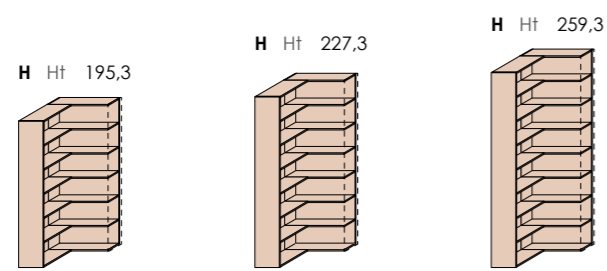

COD. VF10.09U VF10.10R VF10.11X

A
B

Ripiani mobili Movable shelves

In nobilitato
Melamine-coated

Sp Th 2,5
P Dpt 30,8

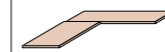

COD. VF10.23R

PASSANTI SEE-THROUGH

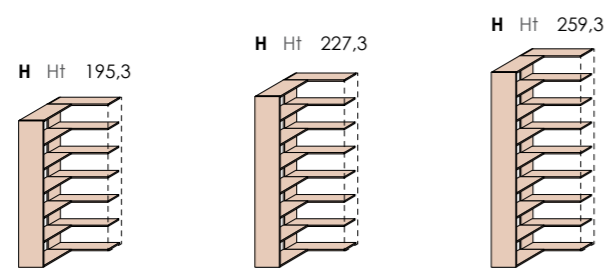

COD. VF10.12D VF10.13L VF10.14S

A
B

In nobilitato
Melamine-coated

Sp Th 2,5
P Dpt 33,3

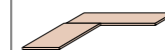

COD. VF10.24X

Fianchi (piede H 0,8 escluso) Side panels (Ht 0.8 foot not included)

Sp Th 2,5

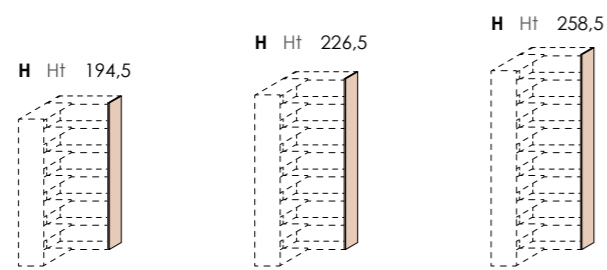

COD. VF08.42B VF08.43H VF08.44Q

A
B

INFORMAZIONI TECNICHE
Disponibile nella versione a giorno oppure con coppia ante. La maniglia è posizionata sempre sull'anta Dx.
Non è possibile invertire gli ingombri.

TECHNICAL INFORMATION
Available in open version or with pair of doors.
Handle is always provided on the Right door.
Size proportion changes are not available.

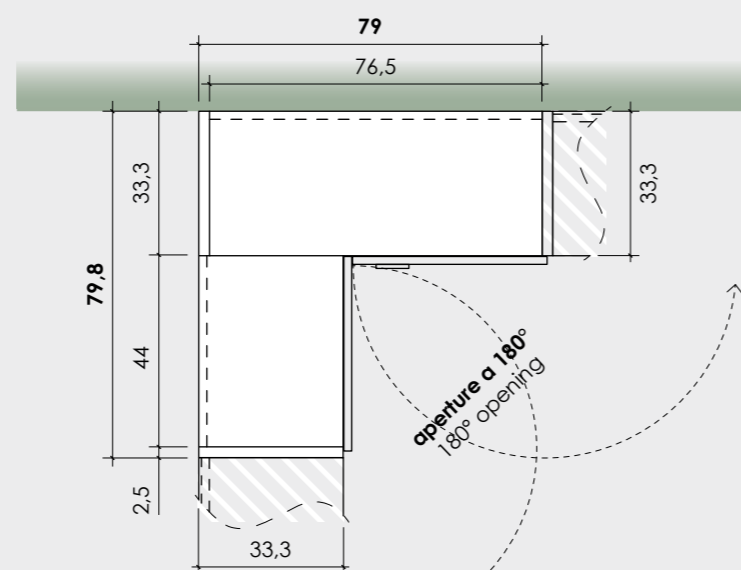

Libreria INFINITY terminale - P 33,3

End-bookshelf INFINITY - Dpt 33.3

Ripiano mobile Movable shelf

In nobilitato
Melamine-coated

Sp Th 2,5
P Dpt 30,8



COD. VF10.25D

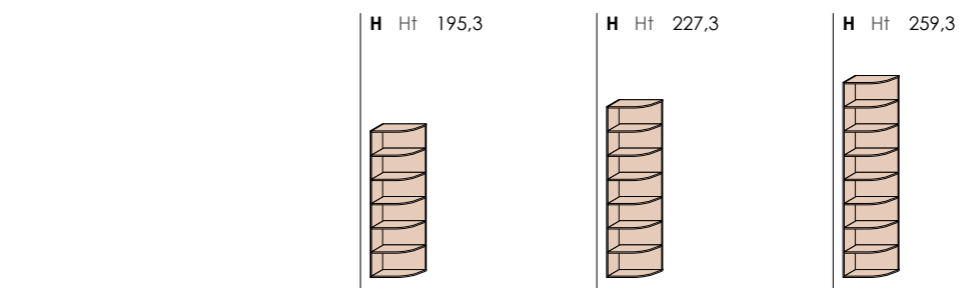

COD. VF10.18T VF10.19Z VF10.20W

A
B

INFORMAZIONI TECNICHE Disponibile solo nella versione a giorno.

TECHNICAL INFORMATION
Available only in open version.

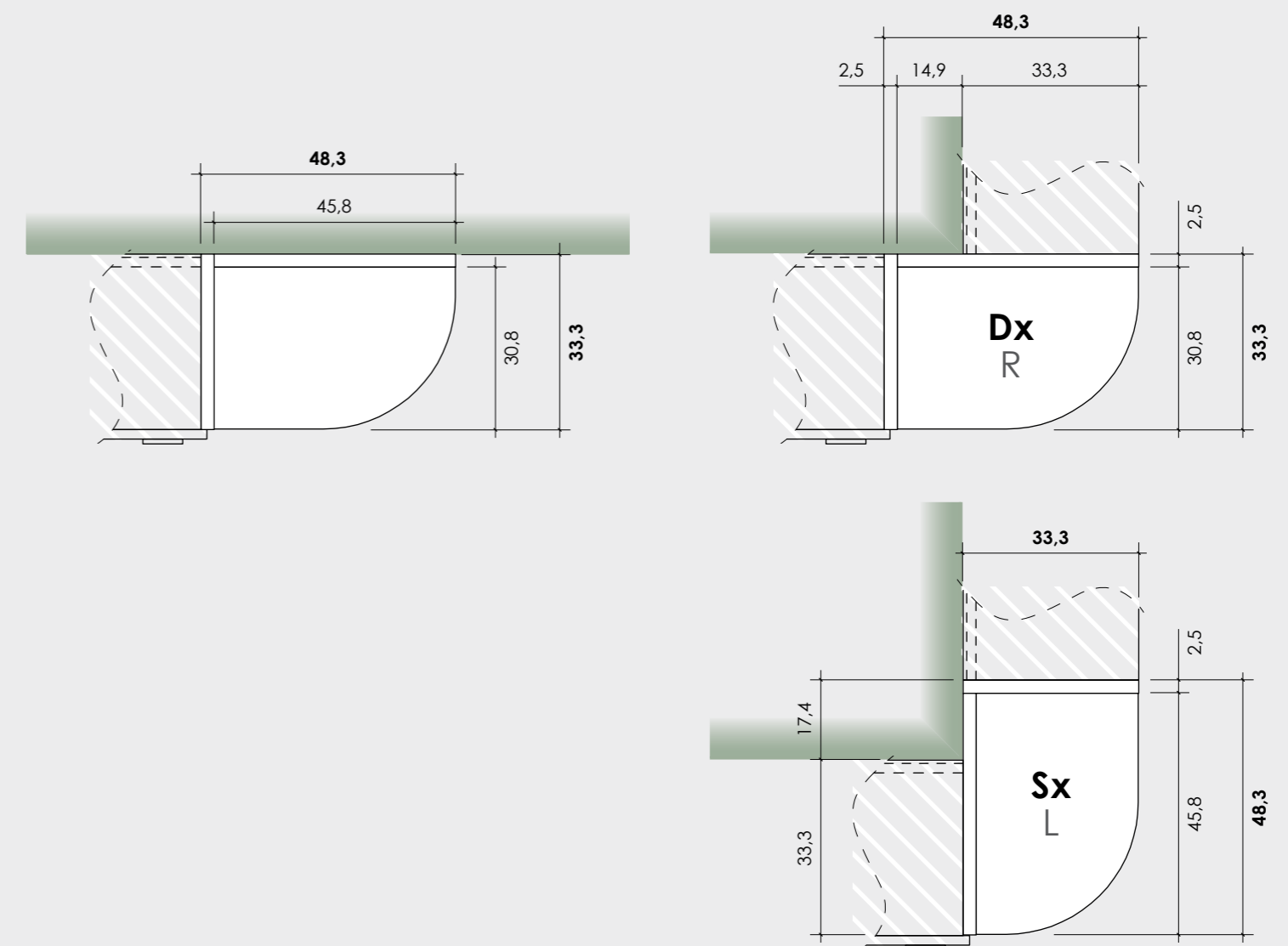

! Consigliamo l'utilizzo del nostro software grafico. È indispensabile graficare e/o inviare un disegno della composizione completa. Per la corretta personalizzazione dei fianchi si raccomanda di vestire i moduli libreria con ante, cassetti, ripiani e schiene. Tutte le composizioni devono essere completate con fianco finale.

We recommend using our graphic software. It is necessary to plot and/or send a drawing of the whole composition. For a correct customization of the side panels, we recommend you to integrate the modular bookcase units with doors, drawers, shelves and back panels. Each composition must be completed with end side panel.

Facciate Fronts
VOLO

Finiture GRUPPO 1
GROUP 1 finishes

Finiture GRUPPO 2
GROUP 2 finishes

Rovere white*

A ☆ Rovere white RW3Q	A ☆ Noce brina NB5T	A Bianco opaco B17A	A Grigio Dorian GL4R	B ☆ Cemento artico CA7A	B ☆ Rovere gesso RG9L
B ☆ Royal oak RS4B	B ☆ Rovere cognac RC3Q	B Grigio titanio GZ8T			
B Papaya PP7H	B Miele ML4B	B Oliva LV5T	B Cadaques CQ3Q		

Vetri Glass

Ante Doors
WINDOW

Colori telaio
Frame colours

Trasparente TR9M	Trasparente fumé FT8P	Stop sol ST6P	Specchio SP7L	Alluminio AL1A	Titan grey TG7H
----------------------------	---------------------------------	-------------------------	-------------------------	--------------------------	---------------------------

Rovere white* Finitura unica per tutti i componenti in pannello presenti a listino non evidenziati con il colore Finiture GRUPPO 1 e/o Finiture GRUPPO 2.
Unique finish for all the panel components shown in the pricelist not highlighted with the color finishes GROUP 1 and/or finishes GROUP 2.

- A** Finiture in fascia di prezzo A
Finishes in price range A
- B** Finiture in fascia di prezzo B
Finishes in price range B
- ☆ Finiture con effetto materico
Finishes with textured effect

COMPONIBILI E PENSILI
MODULAR UNITS AND HANGING UNITS

Componibili a terra/in appoggio - P 45,8 Floor/support modular units - Dpt 45.8	pag. 202
Componibili sospesi - P 45,8 Suspended modular units - Dpt 45.8	pag. 208
Accessori per componibili Modular units accessories	pag. 210
Pensili - P 32,5 Hanging units - Dpt 32.5	pag. 212
Accessori per pensili Hanging units accessories	pag. 214
Moduli sospesi SNAKE SNAKE suspended modular units	pag. 216

Componibili a terra/in appoggio - P 45,8

Floor/support modular units - Dpt 45.8



- Completare ogni composizione con top e piedi o con top e base.
- Sono compresi ripiani interni ogni 32 cm.
- Per una corretta foratura del top è indispensabile inviare un disegno.
- Frontali disponibili con apertura push-pull (no WINDOW), la scelta della maniglia push-pull determinerà le guide tipo "Quadro" push-pull.

- Complete each composition with top and feet or top and base.
- Inner shelves included every 32 cm.
- It is essential to send a drawing to enable us to drill the top as appropriate.
- Fronts available with push-pull opening (not WINDOW), selecting a push-pull handle will determine the need for "Quadro" type push-pull runners.

	H Ht 32								H Ht 64								H Ht 96		
L W 45																			
COD.	VF11.00Q	VF11.01W	VF11.02C	VF11.03K	VF11.04R	VF11.05X	VF11.06D	VF11.07L	VF11.09Y	VF11.10V	VF11.11B	VF11.12H	VF11.13Q	VF11.14W	VF11.15C	VF24.00F	VF24.01N	VF24.02U	
VOLO	<input type="radio"/> A <input type="radio"/> B																		
WINDOW	<input type="radio"/> A <input type="radio"/> B																		
L W 60																			
COD.	VF11.20A	VF11.21G	VF11.22P	VF11.23V	VF11.24B	VF11.25H	VF11.26Q	VF11.27W	VF11.29K	VF11.30F	VF11.31N	VF11.32U	VF11.33A	VF11.34G	VF11.35P	VF24.40C	VF24.41K	VF24.42R	
VOLO	<input type="radio"/> A <input type="radio"/> B																		
WINDOW	<input type="radio"/> A <input type="radio"/> B																		
L W 90																			
COD.	VF11.40M	VF11.41T	VF11.42Z	VF11.43F	VF11.44N	VF11.45U	VF11.46A	VF11.47G	VF11.49V	VF11.50S	VF11.51Y	VF11.52E	VF11.53M	VF11.54T	VF11.55Z	VF24.80Z	VF24.81F	VF24.82N	
VOLO	<input type="radio"/> A <input type="radio"/> B																		
WINDOW	<input type="radio"/> A <input type="radio"/> B																		
L W 120																			
COD.																			
VOLO	<input type="radio"/> A <input type="radio"/> B																		
WINDOW	<input type="radio"/> A <input type="radio"/> B																		

* Cassettoni L 120 con guide tipo "Quadro" rallentate o push-pull di serie.
W 120 big drawers with slowed down or push-pull "Quadro" type guides as standard.

Sovrapprezzi per cassetti/cassettoni CHARM con guide tipo "Quadro":
Surcharge for drawers/big drawers with type "Quadro" metal runners:
RALLENTATE / PUSH-PULL (per L 45 - 60 - 90)
SLOWED DOWN / PUSH-PULL (for W 45 - 60 - 90)

Sovrapprezzi per rallentatore chiusura:
Surcharge for closing retainer:
ANTA (no vasistas/ribalta)
DOOR (not lift-up/pull-down)
CASSETTO / CASSETTONE
DRAWER / BIG DRAWER

Componibili a terra/in appoggio - P 45,8

Floor/support modular units - Dpt 45.8



- Completare ogni composizione con top e piedi o con top e base.
- Sono compresi ripiani interni ogni 32 cm.
- Per una corretta foratura del top è indispensabile inviare un disegno.
- Frontali disponibili con apertura push-pull (no WINDOW), la scelta della maniglia push-pull determinerà le guide tipo "Quadro" push-pull.

- Complete each composition with top and feet or top and base.
- Inner shelves included every 32 cm.
- It is essential to send a drawing to enable us to drill the top as appropriate.
- Fronts available with push-pull opening (not WINDOW), selecting a push-pull handle will determine the need for "Quadro" type push-pull runners.

H
Ht **96**

H
Ht **128**

L
W **45**

Specificare
cerniera Sx o Dx
Specify hinge
L or R

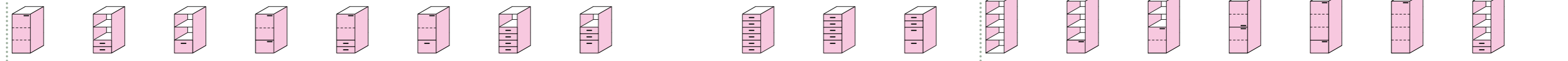

COD. VF24.03A VF24.04G VF24.05P VF24.06V VF24.07B VF24.08H VF24.09Q VF24.10M VF24.11T VF24.12Z VF24.13F VF24.14N VF24.15U VF24.16A VF24.17G VF24.18P VF24.19V VF24.20S

VOLO (A) (B)

WINDOW (A) (B)

L
W **60**

Specificare
cerniera Sx o Dx
Specify hinge
L or R

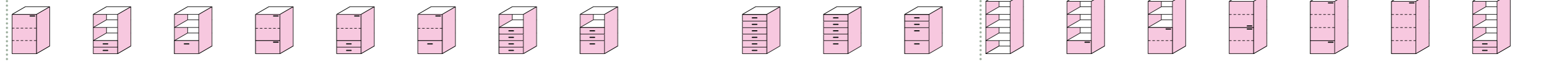

COD. VF24.43X VF24.44D VF24.45L VF24.46S VF24.47Y VF24.48E VF24.49M VF24.50H VF24.51Q VF24.52W VF24.53C VF24.54K VF24.55R VF24.56X VF24.57D VF24.58L VF24.59S VF24.60P

VOLO (A) (B)

WINDOW (A) (B)

L
W **90**

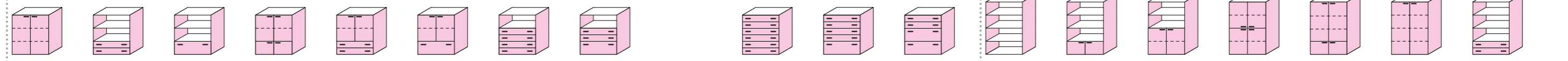

COD. VF24.83U VF24.84A VF24.85G VF24.86P VF24.87V VF24.88B VF24.89H VF24.90E VF24.91M VF24.92T VF24.93Z VF24.94F VF24.95N VF24.96U VF24.97A VF24.98G VF24.99P VF25.00L

VOLO (A) (B)

WINDOW (A) (B)

Sovrapprezzi per cassetti/cassettoni CHARM con guide tipo "Quadro":
Surcharge for drawers/big drawers with type "Quadro" metal runners:
RALLENTATE / PUSH-PULL (per L 45 - 60 - 90)
SLOWED DOWN / PUSH-PULL (for W 45 - 60 - 90)

Sovrapprezzi per rallentatore chiusura:
Surcharge for closing retainer:
ANTA (no vasistas/ribalta)
DOOR (not lift-up/pull-down)
CASSETTO / CASSETTONE
DRAWER / BIG DRAWER

pag. 42
pag. 210

Posizionamento pomelli e maniglie
Knobs and handles position
Accessori per componibili
Modular units accessories

Componibili a terra/in appoggio - P 45,8

Floor/support modular units - Dpt 45.8

- Completare ogni composizione con top e piedi o con top e base.
- Sono compresi ripiani interni ogni 32 cm.
- Per una corretta foratura del top è indispensabile inviare un disegno.
- Frontali disponibili con apertura push-pull (no WINDOW), la scelta della maniglia push-pull determinerà le guide tipo "Quadro" push-pull.

- Complete each composition with top and feet or top and base.
- Inner shelves included every 32 cm.
- It is essential to send a drawing to enable us to drill the top as appropriate.
- Fronts available with push-pull opening (not WINDOW), selecting a push-pull handle will determine the need for "Quadro" type push-pull runners.

H
Ht 128

L
W 45

Specificare
cerniera Sx o Dx
Specify hinge
L or R

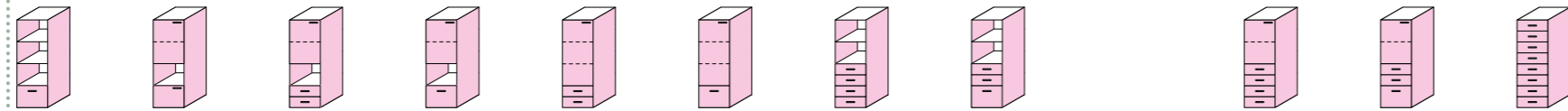

COD. VF24.21Y VF24.22E VF24.23M VF24.24T VF24.25Z VF24.26F VF24.27N VF24.28U VF24.29A VF24.30X VF24.31D

VOLO

A
B

WINDOW

A
B

L
W 60

Specificare
cerniera Sx o Dx
Specify hinge
L or R

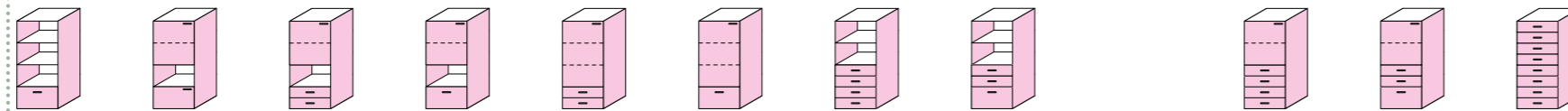

COD. VF24.61V VF24.62B VF24.63H VF24.64Q VF24.65W VF24.66C VF24.67K VF24.68R VF24.69X VF24.70U VF24.71A

VOLO

A
B

WINDOW

A
B

L
W 90

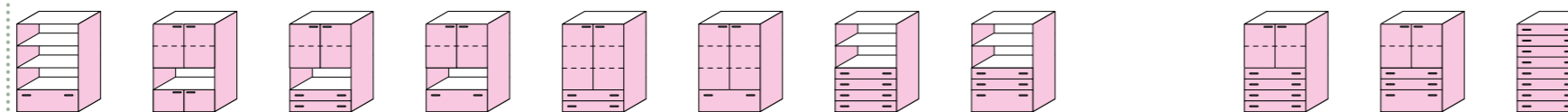

COD. VF25.01S VF25.02Y VF25.03E VF25.04M VF25.05T VF25.06Z VF25.07F VF25.08N VF25.09U VF25.10R VF25.11X

VOLO

A
B

WINDOW

A
B

Sovrapprezzi per cassetti/cassettoni CHARM con guide tipo "Quadro":
Surcharge for drawers/big drawers with type "Quadro" metal runners:

RALLENTATE / PUSH-PULL (per L 45 - 60 - 90)
SLOWED DOWN / PUSH-PULL (for W 45 - 60 - 90)

Sovrapprezzi per rallentatore chiusura:
Surcharge for closing retainer:

ANTA (no vasistas/ribalta)
DOOR (not lift-up/pull-down)
CASSETTO / CASSETTONE
DRAWER / BIG DRAWER

pag. 42
pag. 210





Posizionamento pomelli e maniglie
Knobs and handles position
Accessori per componibili
Modular units accessories

Componibili sospesi - P 45,8

Suspended modular units - Dpt 45.8

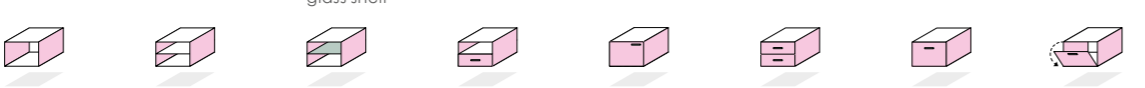
- **Completare ogni composizione con top.**
- Sono completi di attaccaglie per fissaggio al muro dotate di antiganciamento.
- Sono compresi ripiani interni ogni 32 cm.
- Per una corretta foratura del top è indispensabile inviare un disegno.
- Frontali disponibili con apertura push-pull (no WINDOW), la scelta della maniglia push-pull determinerà le guide tipo "Quadro" push-pull.

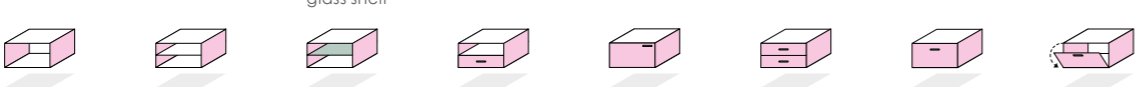
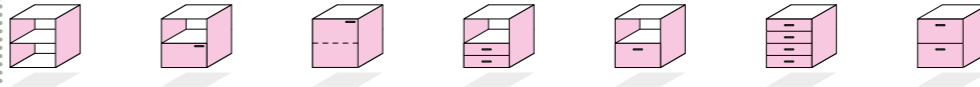
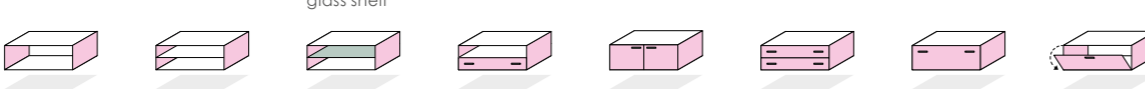
- **Complete each composition with top.**
- They are complete with hangers for fixing to a wall equipped with fischer screws.
- Inner shelves included every 32 cm.
- It is essential to send a drawing to enable us to drill the top as appropriate.
- Fronts available with push-pull opening (not WINDOW), selecting a push-pull handle will determine the need for "Quadro" type push-pull runners.

	H Ht 32								H Ht 64							
L W 45																
COD.	VF12.00U	VF12.01A	VF12.02G	VF12.03P	VF12.04V	VF12.05B	VF12.06H	VF12.07Q	VF12.08W	VF25.20W	VF25.21C	VF25.22K	VF25.23R	VF25.24X	VF25.25D	VF25.26L
VOLO	<input type="radio"/> A <input type="radio"/> B															
WINDOW	<input type="radio"/> A <input type="radio"/> B															
L W 60																
COD.	VF12.10Z	VF12.11F	VF12.12N	VF12.13U	VF12.14A	VF12.15G	VF12.16P	VF12.17V	VF12.18B	VF25.30B	VF25.31H	VF25.32Q	VF25.33W	VF25.34C	VF25.35K	VF25.36R
VOLO	<input type="radio"/> A <input type="radio"/> B															
WINDOW	<input type="radio"/> A <input type="radio"/> B															
L W 90																
COD.	VF12.20E	VF12.21M	VF12.22T	VF12.23Z	VF12.24F	VF12.25N	VF12.26U	VF12.27A	VF12.28G	VF25.40G	VF25.41P	VF25.42V	VF25.43B	VF25.44H	VF25.45Q	VF25.46W
VOLO	<input type="radio"/> A <input type="radio"/> B															
WINDOW	<input type="radio"/> A <input type="radio"/> B															
L W 120																
COD.									VF12.37F VF12.38N							
VOLO	<input type="radio"/> A <input type="radio"/> B															
WINDOW	<input type="radio"/> A <input type="radio"/> B															

Sovrapprezzi per cassette/cassettone CHARM con guide tipo "Quadro":
Surcharge for drawers/big drawers with type "Quadro" metal runners:



RALLENTATE / PUSH-PULL (per L 45 - 60 - 90)
SLOWED DOWN / PUSH-PULL (for W 45 - 60 - 90)

Sovrapprezzi per rallentatore chiusura:
Surcharge for closing retainer:

ANTA (no vasistas/ribalta)
DOOR (not lift-up/pull-down)
CASSETTO / CASSETTONE
DRAWER / BIG DRAWER

pag. 42
pag. 210

Posizionamento pomelli e maniglie
Knobs and handles position
Accessori per componibili
Modular units accessories

	Ripiani interni Inner shelves	Ripiani interni in vetro trasparente Transparent glass inner shelves Solo ripiani a vista e ripiani all'interno delle ante Only shelves in open units and shelves within doors	Ripiani interni con led Inner shelves with led Da completare con alimentatore COD. VF32.56S To be completed with power pack COD. VF32.56S
	Sp Th 2,5 P Dpt 41,7 L W 41,3 56,3 86,3	Sp Th 0,8 P Dpt 41,2 L W 41,3 56,3 86,3	Sp Th 2,5 P Dpt 40,7 L W 41,3 56,3 86,3
			
L W	COD.	COD.	COD.
45	VF34.56A	VF34.59V	VF34.62E
60	VF34.57G	VF34.60S	VF34.63M
90	VF34.58P	VF34.61Y	VF34.64T

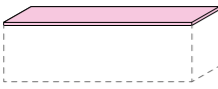
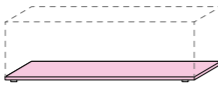

	Top Sp 2,5 - P 45,8 Top Th 2,5 - Dpt 45,8	Base H 3 - P 45,8 Base Ht 3 - Dpt 45,8
		
L W	COD.	COD.
45	(A) VF11.60X (B) VF11.60Y	VF11.70C
60	(A) VF11.61D (B) VF11.61E	VF11.71K
90	(A) VF11.62L (B) VF11.62M	VF11.72R
120	(A) VF11.63S (B) VF11.63T	VF11.73X
135	(A) VF11.64Y (B) VF11.64Z	VF11.74D
180	(A) VF11.65E (B) VF11.65F	VF11.75L
225	(A) VF11.66M (B) VF11.66N	VF11.76S
270	(A) VF11.67T (B) VF11.67U	VF11.77Y
Su misura Custom-made min 30 max 360	(A) VF11.68Z (B) VF11.68A	VF11.78E

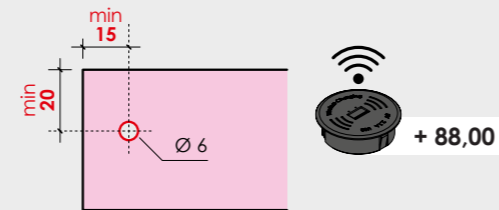
RICARICA WIRELESS INTEGRATA NEL TOP
INTEGRATED WIRELESS CHARGING IN THE TOP

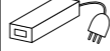

È possibile dotare la composizione di Ricarica wireless + presa USB per la quale è necessaria l'esecuzione di 1 foro su top (foratura a nostra cura solo se indicata da un disegno esplicativo. Foro su schiena e cappello a cura del cliente). **Applicabile in corrispondenza di elementi a giorno o con ante.**

It is possible to equip the composition of Wireless recharging + USB socket for which it is necessary to perform 1 hole on top (drilling only if indicated by an explanatory drawing. The hole in back and top of base unit to be made by customer). **Applicable to open elements or with doors.**

	Alimentatore per ripiano con led Power pack for shelf with led lighting (cavo L 200 cm - 20 watt) in grado di supportare: da 1 a 6 ripiani L 45 e 60, da 1 a 4 ripiani L 90 (cable W 200 cm - 20 watt) capable of lighting from: 1 to 6 shelves W 45 and 60, 1 to 4 shelves W 90	Interruttore wireless per ripiano con led Wireless switch for shelf with led lighting
		
COD.	VF32.56S	VF32.57Y

COME DETERMINARE I PIEDI NECESSARI:
HOW TO CALCULATE NUMBER OF FEET NEEDED:



Si applicano esclusivamente sul fondo. Esempio: Tante confezioni di 4 piedini ALFA 16, ALFA 25 e ETA da fissare sotto ogni elemento.

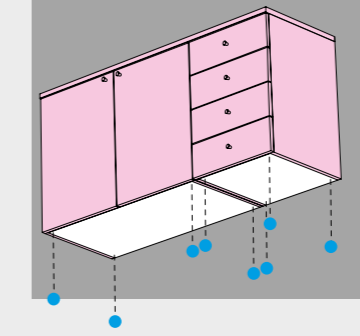

Be applied underneath to the bottom panel only. Example: One pack of 4 ALFA 16, ALFA 25 and ETA feet for fixing underneath each element.

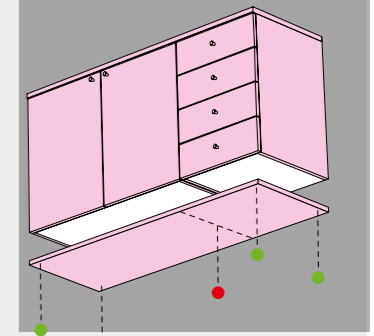

Si applicano esclusivamente sotto la Base. Esempio: Una confezione di 4 piedini SIGMA da fissare alle estremità più 1 piedino GAMMA centrale da sistemare in corrispondenza del punto di unione fra le unità.

Be applied underneath to the base only. Example: One pack of 4 SIGMA feet for fixing at the ends plus one "GAMMA central" feet for placing at each joint between units are always required.

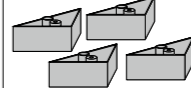

	Piedini regolabili - Confezione 4 pezzi Adjustable feet - Pack of 4		
	ALFA 16 H Ht 1,6	ALFA 25 H Ht 2,5	ETA L W 10 H Ht 4
			
COD.	VF33.86N	VF32.32E	VF32.33M

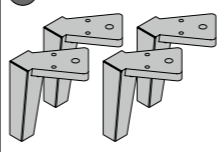
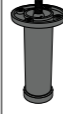
	Piedini regolabili - Confezione 4 pezzi Adjustable feet - Pack of 4	
	SIGMA L W 8,3 H Ht 11	GAMMA L W 3,6 H Ht 11
		centrale central 
COD.	VF32.34T	VF32.35Z



Pensili - P 32,5

Hanging units - Dpt 32.5

- L'utilizzo del top non è obbligatorio.
- Sono completi di attaccaglie per fissaggio al muro di tipo invisibile e dotate di antifiscamento.
- Sono compresi ripiani interni ogni 32 cm.
- Frontali disponibili con apertura push-pull (no WINDOW).

- Using the top is not mandatory.
- They are complete with hangers for fixing to an invisible type wall and equipped with fischer screws.
- Included inner shelves every 32 cm.
- Fronts available with push-pull opening (not WINDOW).

	H Ht 32				H Ht 96		H Ht 128		H Ht 160		
L W 30											
COD.					VF12.54X	VF12.55D	VF12.64C	VF12.65K	VF12.74H	VF12.75Q	VF12.76W
VOLO	A B				A B		A B		A B		
WINDOW	A B				A B		A B		A B		
L W 45											
COD.	VF12.50W	VF12.51C	VF12.52K	VF12.53R	VF12.56L	VF12.57S	VF12.58Y	VF12.59E	VF12.77C	VF12.78K	VF12.79R
VOLO	A B				A B		A B		A B		
WINDOW	A B				A B		A B		A B		
L W 60											
COD.	VF12.60B	VF12.61H	VF12.62Q	VF12.63W	VF12.66R	VF12.67X	VF12.68D	VF12.69L			
VOLO	A B				A B		A B				
WINDOW	A B				A B		A B				
L W 90											
COD.	VF12.70G	VF12.71P	VF12.72V	VF12.73B					VF12.92F VF12.93N		
VOLO	A B								A B		
WINDOW	A B								A B		



Sovrapprezzi per rallentatore chiusura:
Surcharge for closing retainer:
ANTA (no vasistas/ribalta)
DOOR (not lift-up/pull-down)

pag. 42
pag. 214

Posizionamento pomelli e maniglie
Knobs and handles position
Accessori per pensili
Hanging units accessories

Accessori per pensili

Hanging units accessories

	Ripiani interni Inner shelves	Ripiani interni in vetro trasparente Transparent glass inner shelves	Ripiani interni con led Inner shelves with led
	Sp Th 2,5 P Dpt 28,6 L W 26,3 41,3 56,3 86,3	Sp Th 0,8 P Dpt 28 L W 26,3 41,3 56,3 86,3	Sp Th 2,5 P Dpt 27,6 L W - 41,3 56,3 86,3
			
	Solo ripiani a vista e ripiani all'interno delle ante Only shelves in open units and shelves within doors		Da completare con alimentatore COD. VF32.56S To be completed with power pack COD. VF32.56S
L W	COD.	COD.	COD.
30	VF31.22V	VF31.23B	-
45	VF34.65Z	VF34.68U	VF34.71D
60	VF34.66F	VF34.69A	VF34.72L
90	VF34.67N	VF34.70X	VF34.73S

Top Sp 2,5 - P 33,3
Top Th 2,5 - Dpt 33,3



L W		COD.
30	(A)	VF12.80N
	(B)	
45	(A)	VF12.81U
	(B)	
60	(A)	VF12.82A
	(B)	
90	(A)	VF12.83G
	(B)	
120	(A)	VF12.84P
	(B)	
135	(A)	VF12.85V
	(B)	
180	(A)	VF12.86B
	(B)	
225	(A)	VF12.87H
	(B)	
270	(A)	VF12.88Q
	(B)	
Su misura Custom-made min 30 max 360	(A)	VF12.89W
	(B)	

Alimentatore per ripiano con led
Power pack for shelf with led lighting

(cavo L 200 cm - 20 watt) in grado di supportare: da 1 a 6 ripiani L 45 e 60, da 1 a 4 ripiani L 90
(cable W 200 cm - 20 watt) capable of lighting from: 1 to 6 shelves W 45 and 60, 1 to 4 shelves W 90

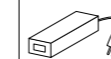

COD. VF32.56S

Interruttore wireless per ripiano con led
Wireless switch for shelf with led lighting

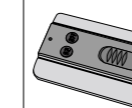

COD. VF32.57Y

Moduli sospesi SNAKE

SNAKE suspended modular units



- Sono completi di attaccaglie regolabili, per fissaggio al muro, di tipo invisibile e dotate di antisganciamento.
- Carico massimo consigliato (al netto dell'elemento): 20 Kg. N.B. Il carico si intende uniformemente distribuito sull'elemento.
- Frontali disponibili con apertura push-pull (no WINDOW).

- Including adjustable, concealed hangers for wall-mounting with anti-release mechanism.
- Maximum recommended load (net of element): 20 Kg. N.B. The load is intended as evenly distributed on the element.
- Fronts available with push-pull opening (not WINDOW).

L W 90
H Ht 14,8

P Dpt 26



COD. VF17.10W

A
B

Sx L

Dx R

L W 90
H Ht 32

L W 119,5
H Ht 61,5

L W 147,5
H Ht 32

L W 177,5
H Ht 44,3

L W 177,5
H Ht 32

L W 90
H Ht 32

L W 119,5
H Ht 61,5

L W 147,5
H Ht 32

L W 177,5
H Ht 32

L W 177,5
H Ht 44,3

P Dpt 26

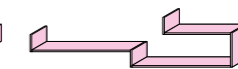
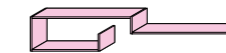
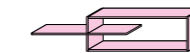
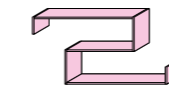
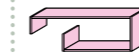
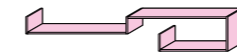
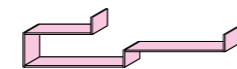
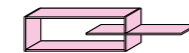
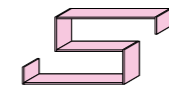
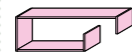

COD. VF17.11C VF17.12K VF17.13R VF17.14X VF17.15D VF17.16L VF17.17S VF17.18Y VF17.19E VF17.20B

A
B

L W 119,5

H Ht 61,6

P Dpt 32,5

P Dpt 32,5

P Dpt 32,5

P Dpt 32,5

P Dpt 32,5

P Dpt 32,5

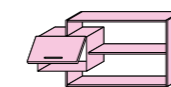
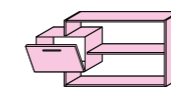
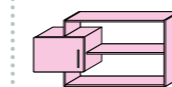
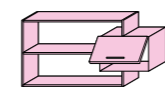
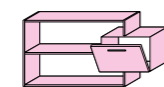
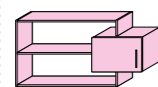

COD. VF17.21H* VF17.22Q VF17.23W VF17.24C* VF17.25K VF17.26R

VOLO

WINDOW

A
B
A
B

Sovrapprezzi per rallentatore chiusura:
Surcharge for closing retainer:
ANTA (no vasistas/ribalta)
DOOR (not lift-up/pull-down)

Moduli sospesi SNAKE

SNAKE suspended modular units

- Sono completi di attaccaglie regolabili, per fissaggio al muro, di tipo invisibile e dotate di antisganciamento.
- Carico massimo consigliato (al netto dell'elemento): 20 Kg. N.B. Il carico si intende uniformemente distribuito sull'elemento.
- Frontali disponibili con apertura push-pull (no WINDOW).

- Including adjustable, concealed hangers for wall-mounting with anti-release mechanism.
- Maximum recommended load (net of element): 20 Kg. N.B. The load is intended as evenly distributed on the element.
- Fronts available with push-pull opening (not WINDOW).

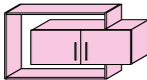
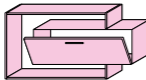
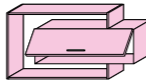
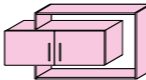
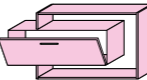
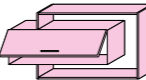
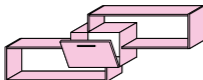
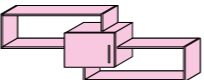
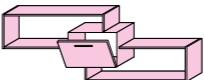
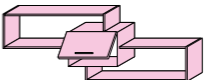
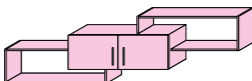
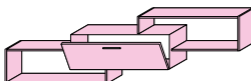
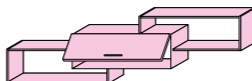
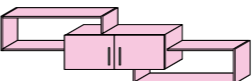
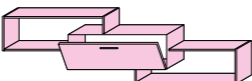
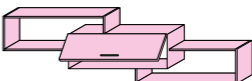
	Sx L			Dx R		
L W	119,5			119,5		
	H Ht			61,6		
	P Dpt 32,5	P Dpt 32,5	P Dpt 32,5	P Dpt 32,5	P Dpt 32,5	P Dpt 32,5
						
COD.	VF17.27X	VF17.28D	VF17.29L	VF17.30G	VF17.31P	VF17.32V
VOLO	(A)	(B)				
WINDOW	(A)	(B)				
L W	160,9			160,9		
	H Ht			61,6		
	P Dpt 32,5	P Dpt 32,5	P Dpt 32,5	P Dpt 32,5	P Dpt 32,5	P Dpt 32,5
						
COD.	VF17.33B *	VF17.34H	VF17.35Q	VF17.36W *	VF17.37C	VF17.38K
VOLO	(A)	(B)				
WINDOW	(A)	(B)				
L W	205,9			205,9		
	H Ht			61,6		
	P Dpt 32,5	P Dpt 32,5	P Dpt 32,5	P Dpt 32,5	P Dpt 32,5	P Dpt 32,5
						
COD.	VF17.39R	VF17.40N	VF17.41U	VF17.42A	VF17.43G	VF17.44P
VOLO	(A)	(B)				
WINDOW	(A)	(B)				

Sovrapprezzi per rallentatore chiusura:
Surcharge for closing retainer:
ANTA (no vasistas/ribalta)
DOOR (not lift-up/pull-down)

pag. 42

Posizionamento pomelli e maniglie
Knobs and handles position

Facciate Fronts
VOLO

Finiture GRUPPO 1
GROUP 1 finishes

Finiture GRUPPO 2
GROUP 2 finishes



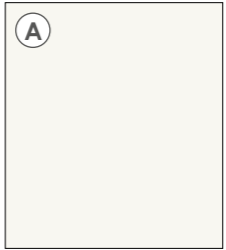
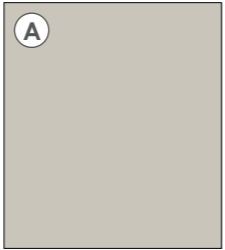
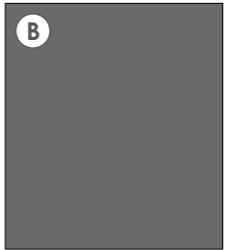

Rovere white*

 (A) ☆ Rovere white RW3Q	 (A) ☆ Noce brina NB5T	 (A) Bianco opaco BI7A	 (A) Grigio Dorian GL4R	 (B) ☆ Cemento artico CA7A	 (B) ☆ Rovere gesso RG9L
 (B) ☆ Royal oak RS4B	 (B) ☆ Rovere cognac RC3Q	 (B) Grigio titanio GZ8T			
 (B) Papaya PP7H	 (B) Miele ML4B	 (B) Oliva LV5T	 (B) Cadaques CQ3Q		

Vetri Glass

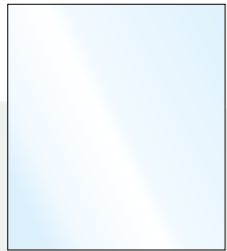
Ante Doors
WINDOW

Colori telaio
Frame colours

 Trasparente TR9M	 Trasparente fumé FT8P	 Stop sol ST6P	 Specchio SP7L	 Alluminio AL1A	 Titan grey TG7H
--	---	---	--	--	---

Rovere white* Finitura unica per tutti i componenti in pannello presenti a listino non evidenziati con il colore Finiture GRUPPO 1 e/o Finiture GRUPPO 2.
Unique finish for all the panel components shown in the pricelist not highlighted with the color finishes GROUP 1 and/or finishes GROUP 2.

- (A) Finiture in fascia di prezzo A
Finishes in price range A
- (B) Finiture in fascia di prezzo B
Finishes in price range B
- (☆) Finiture con effetto materico
Finishes with textured effect

RESIDENCE E HOTEL
RESIDENCE AND HOTEL

Elementi per hotel e contract Contract and hotel elements	pag. 222
Testate continue su misura e letti accostabili Custom-made continuous headboards and his beds	pag. 224
Scheda prodotto Product information	pag. 226
Condizioni generali di vendita General sales conditions	pag. 228

Elementi per hotel e contract

Contract and hotel elements

Armadi Wardrobes	L W 45 P Dpt 54,5	L W 60 P Dpt 54,5	L W 90 P Dpt 54,5	Fianco finale End panel
H Ht 225,6				
H Ht 225,6				
P Dpt 54,5				
Sp Th 1,8				
COD.	VF12.98V	VF12.99B	VF13.00Y	VF00.99Q
VOLO	A	B		

Armadi Wardrobes	L W 45 P Dpt 54,5	L W 60 P Dpt 54,5	L W 90 P Dpt 54,5	Fianco finale End panel
H Ht 257,6				
H Ht 257,6				
P Dpt 54,5				
Sp Th 1,8				
COD.	VF13.02M	VF13.03T	VF13.01E	VF01.99U
VOLO	A	B		

Portavaligie e pannelli a muro Luggage stands and wall panels	H Ht 61 P Dpt 52,8 L W 90	H Ht 185 P Dpt 2,6 L W 90	H Ht 185 P Dpt 6,6 L W 90	H Ht 185 P Dpt 5,6 L W 90
COD.	VF13.29T	VF13.30Q	VF13.31W	VF13.32C
VOLO	A	B		

Accessori Accessories	5 profili antisdrucchiolo per portavaligie 5 anti-sliding profiles for luggage stand P Dpt 45 Con biadesivo With biadhesive tape	Specchio per pannelli a muro Mirror for wall panels H Ht 125 L W 60	Appendiabiti Clothes hook BOLLINO P Dpt 4 Ø 10	PLUS H Ht 6,5 P Dpt 3 L W 4,3
COD.	VF34.74Y	VF34.75E	VF32.61Q	VF32.62W

Scrivanie portarfrigo Fridge holder desks	H Ht 77,6 P Dpt 57,1 L W 120	H Ht 77,6 P Dpt 57,1 L W 135	Su misura Customized min 91 - max 220 H Ht 77,6 P Dpt 57,1
COD. senza frigo without fridge	VF13.05F	VF13.06N	VF13.07U
VOLO	A	B	
COD. con frigo with fridge	VF13.10D	VF13.11L	VF13.12S
VOLO	A	B	

Scrivanie portarfrigo + portavaligie Fridge holder desks + luggage stands	L W 210	L W 225
COD. senza frigo without fridge	VF13.15M	VF13.16T
VOLO	A	B
COD. con frigo with fridge	VF13.20K	VF13.21R
VOLO	A	B

Frigobar da incasso Built-in refrigerator
H Ht 54 P Dpt 45 L W 39
interno inside H Ht 45 P Dpt 24 L W 31,5
Colore esterno: nero. Capacità: 40 Litri. Peso: 13,5 Kg. Tensione di alimentazione: 220 V.
Outside colour: black. Capacity: 40 Litres. Weight: 13.5 Kg. Power supply voltage: 220V.
COD.
VF34.76M

Sovrapprezzi per rallentatore chiusura:
Surcharge for closing retainer:



ANTA DOOR

pag. 42

Posizionamento pomelli e maniglie
Knobs and handles position

Testate continue su misura e letti accostabili

Custom-made continuous headboards and his beds

	Senza mensole Without shelves H Ht 90 L W min 45 - max 360 Sp Th 1,8 	Con 1 mensole With 1 shelf H Ht 90 P Dpt 27,8 (26 + 1,8) L W min 45 - max 360 Specificare Sx o Dx (disegno Sx) Specify L or R (drawings L)	Con 2 mensole With 2 shelves H Ht 90 P Dpt 27,8 (26 + 1,8) L W min 90 - max 360	Mensola Shelf P Dpt 26 L W 45 Sp Th 2,5 
COD.	VF13.99F	VF14.00C	VF14.01K	VF14.02R
	(A)			
	(B)			

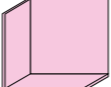
	Con 1 mensola WEB With 1 WEB shelf H Ht 90 P Dpt 21,6 (19,8 + 1,8) L W min 45 - max 360 Specificare Sx o Dx (disegno Sx) Specify L or R (drawings L)	Con 2 mensole WEB With 2 WEB shelves H Ht 90 P Dpt 21,6 (19,8 + 1,8) L W min 90 - max 360	Mensola WEB WEB shelf H Ht 42 P Dpt 19,8 L W 42 
COD.	VF14.03X	VF14.04D	VF16.43C
	(A)		
	(B)		

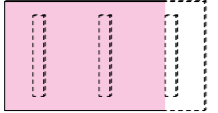
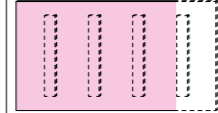
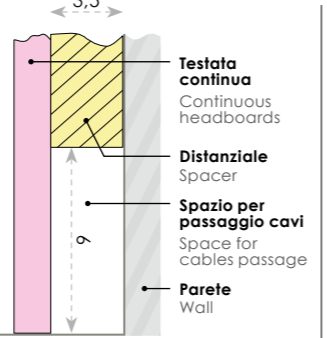
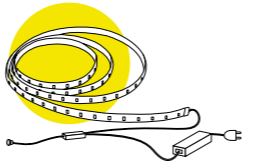
Senza mensole, con distanziali Without shelves, with spacers I distanziali permettono il passaggio di eventuali cavi elettrici. The spacers allow the passage of any electrical cables. H Ht 90 L W min 90 - max 200 Sp Th 5,3 	Senza mensole, con distanziali Without shelves, with spacers I distanziali permettono il passaggio di eventuali cavi elettrici. The spacers allow the passage of any electrical cables. H Ht 90 L W min 210 - max 310 Sp Th 5,3 	 <p>3,5</p> <p>Testata continua Continuous headboards</p> <p>Distanziale Spacer</p> <p>Spazio per passaggio cavi Space for cables passage</p> <p>Parete Wall</p>	Kit illuminazione led per testate letti. Led lighting kit for bed headboards. Fascia led L 120, 1 interruttore, cablaggi Led strip W 120, 1 switch, wiring 
COD.	VF14.05L	VF14.06S	VF34.00K
	(A)		
	(B)		

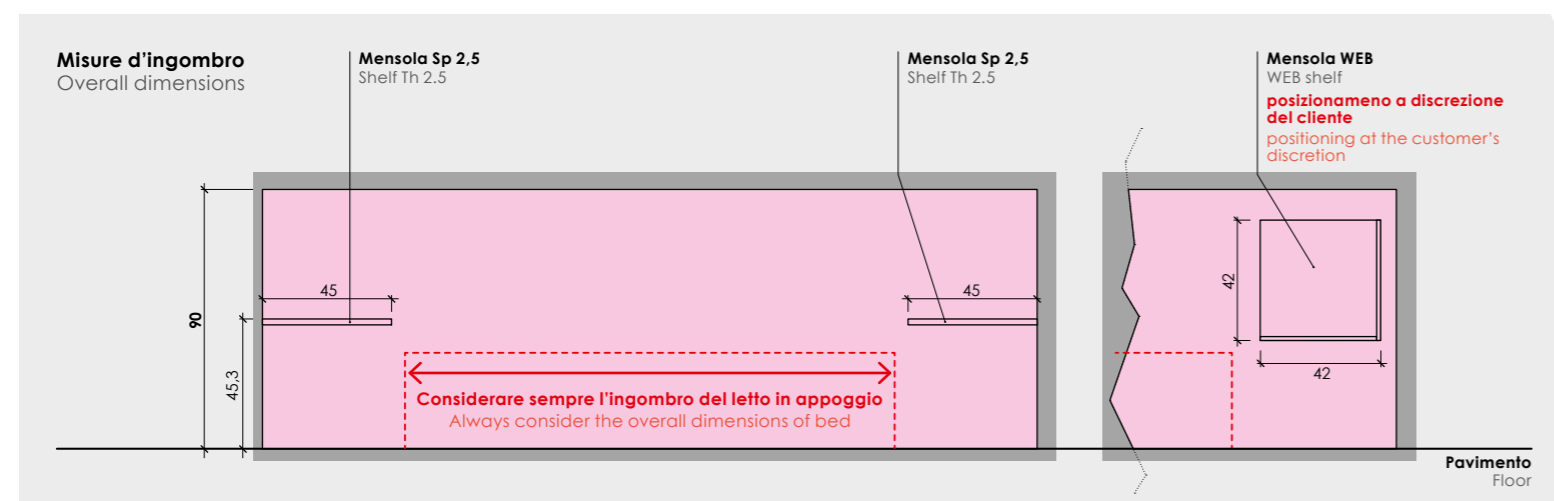

Microfibra ECOCHIC
ECOCHIC microfibre
Z66H Z67M Z68Q Z69T Z70R Z71U

* **RETE A CURA DEL CLIENTE.** In fase di ordinazione è indispensabile indicare L della rete.
BASE TO BE SUPPLIED BY THE CUSTOMER. When ordering, you must state the width of base.
 Prodotto realizzato con componenti ignifughi in classe 1.
Product made with class 1 fire retardant components.
 Consegna 4 settimane circa dal ricevimento dell'ordine.
Delivery approximately 4 weeks from order receipt.

Letti accostabili

Beds for continuous headboards

SPARTA

Rete a filo sponda
Bed base aligned with side

H Ht 46,1
P Dpt 197
L W 87,8
 97,8
 127,8
 167,8

NETTUNO

H Ht 33,6
P Dpt 199,5
L W 90
 100
 129
 170

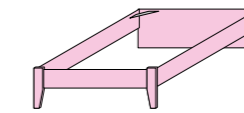
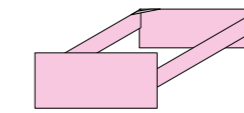

rete L bed base W	COD.	interno letto internal dimensions	COD.	interno letto internal dimensions
80 x 190	VF14.10H	81,5 x 191	VF14.20P	81,5 x 191
90 x 190	VF14.11Q	91,5 x 191	VF14.21V	91,5 x 191
120 x 190	VF14.12W	121,5 x 191	VF14.22B	121,5 x 191
160 x 190	VF14.13C	161,5 x 191	VF14.23H	161,5 x 192,5
Su misura Customized	50÷250 * VF14.14K			

KANT

Completi di rete a doghe e sfoderabili
With lifting base and removables

Materiale imbottitura: Poliuretano flessibile densità 35 kg/m³. Vellutina anti fiamma.
Padding material: Flexible polyurethane, density 35 kg/m³. Flame resistant material.

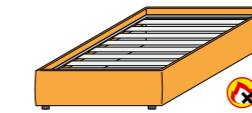

H Ht 37
P Dpt 201
L W -
 98
 128
 168

Fodere di rivestimento in microfibra
Lavabili
Microfibre covers
Washable

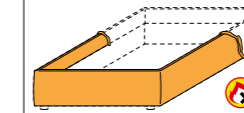

rete L bed base W	COD.	interno letto internal dimensions	COD.	rete L bed base W
90 x 190	VF14.30U	92 x 195	VF34.77T	90
120 x 190	VF14.31A	122 x 195	VF34.78Z	120
160 x 190	VF14.32G	162 x 195	VF34.79F	160

Scheda prodotto

Product information

DESCRIZIONE DEI MATERIALI:

STRUTTURA (fianchi, cappelli, ripiani, piani lavoro, mensole): Realizzata con pannelli di particelle di legno Sp 18, 25 o 35 mm, con basso contenuto di formaldeide (CARB P2), nobilitati 2 lati con superficie melamminica. Bordi: in ABS o polipropilene (Sp da 0,5 a 2 mm) o in decorativo (Sp 0,4 mm).

SCHIENALI INTERNI - FONDINI CASSETTI: Pannelli in fibra ad alta densità (HDF) Sp 3 mm, con un lato trattato con laccatura superficiale o applicazione di carta stampata effetto legno.

ANTE A BATTENTE E FACCIATA CASSETTI "VOLO": In pannelli di particelle di legno Sp 18 mm con basso contenuto di formaldeide (CARB P2), nobilitati 2 lati rivestiti con decorativo melamminico. Finitura perimetrale ottenuta con applicazione di bordo in ABS Sp 0,8 mm. Rallentatori di chiusura ante a battente opzionali. Versione con specchio: specchio Sp 4 mm incollato al pannello con biadesivo.

ANTE A BATTENTE "WINDOW" CON VETRO

Montanti e traversi in trafilato di alluminio, anodizzato o anodizzato in elettrocolore. Vetro temperato e specchio Sp 4 mm. Rallentatori di chiusura ante a battente opzionali.

ANTE SCORREVOLI: In pannello: Realizzata in pannelli di particelle di legno con basso contenuto di formaldeide (CARB P2), nobilitati sui 2 lati con superficie melamminica Sp 18 mm. **Versione a specchio:** con specchio Sp 4 mm incollato al pannello e cornice di fissaggio superiore ed inferiore in metallo verniciato con polveri epossidiche o rivestito con decorativo. **Maniglioni laterali:** in alluminio anodizzato, verniciato o rivestito con decorativo, con tiranti di regolazione interni.

ANTA SCORREVOLE (binari e carrucole): Struttura metallica con regolazioni altezza di scorrimento. Rallentatori in chiusura e apertura opzionali.

COMPONENTI PER TESTATE E PEDIERE LETTI: Pannelli vedi "STRUTTURA". Particolari in legno di faggio o aioux tinti o laccati o MDF rivestito con decorativo.

MATERASSI IN SPUGNA: Poliuretano espanso rivestiti in tessuto (vedi specifiche all'interno del listino).

MATERASSI A MOLLE OPPURE IN LATTICE: vedi specifiche all'interno del listino.

RETI: Struttura in metallo verniciato con vernici liquide o epossidiche, doghe in multistrato di betulla.

CUSCINI POGGIASCHIENA: Imbottitura in fibra poliestere vergine. Rivestimento interno 100% poliestere; Rivestimento esterno vedi specifiche all'interno del listino.

TAVOLI: Con piani e allunghe in particelle di legno, con basso contenuto di formaldeide (CARB P2) nobilitati 2 lati, rivestiti con decorativo melamminico e bordi in testa in ABS Sp 0,8 mm. Basamento in particelle di legno, nobilitato 2 lati Sp 25 mm. Gambe in faggio tinte legno o laccate.

MANIGLIE: Maniglie in legno: faggio o frassino tinti legno. Maniglie in materiale plastico: ABS laccato o elastomero. Maniglie in metallo: zama o alluminio anodizzato.

SEDIE LEGNO: Struttura in faggio tinto legno o laccato. Fondino in tessuto o faggio laccato.

SEDIE METALLO: Struttura in metallo verniciato. Scocca, schienale e fondino in polipropilene stampato nei vari colori.

ELEMENTI PORTANTI IN METALLO (gambe, travi, scrivanie, reggi mensole, ecc.): Acciaio verniciato a polveri epossidiche. Montanti sistema "EASY" in alluminio con cremagliera.

ALTRI PARTICOLARI: Cerniere, serrature e ferramenta varia per assemblaggio in metallo. Guide cassette in metallo. Piedini armadi in metallo (regolabili) o plastica (fissi). Spondine cassette in pannelli di particelle di legno (CARB P2) rivestite in PVC. Ripiani in vetro temprato trasparente. Reggi pensili in lamiera zincata con regolazione in profondità ed altezza + antiganciamento.

DESCRIPTION OF MATERIALS:

STRUCTURE (side panels, tops, shelves, worktops and wall shelves): Constructed in wooden particle board panels Th 18, 25 or 35 mm, with low formaldehyde content (CARB P2), melamine-coated on 2 sides. Edges: in ABS or polypropylene (Th from 0.5 to 2 mm) or in melamine (Th 0.4 mm).

INSIDE BACK PANELS - DRAWER BOTTOMS: HDF board panels Th 3 mm, finished on one side by surface lacquering or application of wood-look printed paper.

"VOLO" HINGED DOORS AND DRAWER FRONTS: In chipboard panels Th 18 mm with low formaldehyde content (CARB P2), finished on 2 sides with decorative melamine. Edges finished by application of ABS edging Th 0.8 mm. Optional soft closing retainers hinged doors. Version with mirror: Th 4 mm mirror glued to the panel with double-sided tape.

"WINDOW" HINGE DOORS WITH GLASS

Supports and crossbeams in extruded anodised or electrocolour anodised aluminium. Tempered glass and mirror Th 4 mm. Optional soft closing retainers hinged doors.

SLIDING DOORS: In panel: Made from wooden particle board panels with low formaldehyde content (CARB P2) finished with melamine surface on 2 sides, Th 18 mm. **Mirror version:** With mirror Th 4 mm glued onto the panel and epoxy powder painted metal mounting frame at top and bottom or finished with decorative melamine. **Long side handles:** Anodized aluminium, painted or with decorative coating, with internal adjuster tie-bolts.

SLIDING DOOR (rails and carriages): Metal structure with travel height adjustment. Cushioned opening and closure devices are optional.

BED HEADBOARD AND FOOTBOARD COMPONENTS: Panels see "STRUCTURE". Details in stained or lacquered beech or aioux wood or MDF board with melamine finish.

FOAM MATTRESSES: Foamed polyurethane with fabric cover (see specifications in price list).

SPRING OR LATEX MATTRESSES: see specifications in price list.

BED BASES: Liquid or epoxy powder painted metal frame, birch plywood slats.

BACK CUSHIONS: Padding in pure polyester fibre. Inner cover 100% polyester. See specifications in price list for outer cover.

TABLES: With tops and extensions in particleboard, with low formaldehyde content (CARB P2) melamine on 2 sides, covered with decorative melamine and ABS top edges Th 0.8 mm. Wooden particle board base, 2-sided, Th 25 mm. Legs in beech wood stained or lacquered.

HANDLES: Wooden handles: wood-stained beech or ash. Plastic handles: Lacquered ABS or elastomer. Metal handles: anodised aluminium or metal alloy.

WOODEN CHAIRS: Wood-stained or lacquered beech frame. Seat in fabric or lacquered beech.

METAL CHAIRS: Painted metal frame. Shell, seat or back in polypropylene printed in the various colours.

METAL SUPPORTING ELEMENTS (legs, beams, desks, shelf holders, etc.): Epoxy powder painted steel. "EASY" system uprights in aluminium with rack mechanism.

OTHER PARTS: Hinges, locks and general hardware for assembly in metal. Drawer runners in metal. Wardrobe feet in metal (adjustable) or plastic (fixed). Drawer sides in wooden particle board panels (CARB P2) finished with PVC. Glass shelves in tempered plate glass. Shelf holders in galvanised sheet metal with depth and height adjustment + anti-detaching device.

**Colombini S.p.A. si riserva di apportare, senza alcun preavviso,
le modifiche che riterrà più opportune al fine di migliorare il prodotto.**

Colombini S.p.A. reserves the right to implement modifications to the current specification,
without notice, in order to improve products.

Ricerca, progetto e impaginazione:
Research, design and paging:

COLOMBINI S.p.A.

VOLO

COLOMBINI S.p.A.

Azienda certificata UNI EN ISO 9001
Azienda certificata UNI EN ISO 14001
Strada Ca' Valentino, 124
47891 Falciano - Repubblica di San Marino

Telefono da Italia 0549 943 573
International calls +378 0549 975 948

www.colombinigroup.com
www.colombinicasa.com

