

**BONO DESIGN Kft.**

1036 Budapest, Bécsi út 81.

06-1/240-02-42

06-30/22-32-120

info@bonodesign.hu

www.bonodesign.hu

# GOLF

ELEMLISTA

Modern Gyerekbútorok

Modern Ifjúsági bútorok

Modern Hálószoba bútorok

Modern Nappali bútorok

**Colombini'Casa**

[bonodesign.hu](http://bonodesign.hu)

# General table of contents



Certifications	6	LOGIK end bookshelves	148	FLEXO walk-in closet Ht 257.6 - corner units	256	FLOTTA system	348
Colour codes and names	7	VELA end bookshelves L 30.7 - Dpt 54	150	FLEXO walk-in closet Ht 103 ÷ 302	258		
Compilation of orders with TGE0 - METRON4 - MULTISTANZA	8	QUID end bookshelves	152	FLEXO walk-in closet Ht 103 ÷ 302 - corner units	260	<b>Groups and Single beds</b>	<b>355</b>
		SMART end bookshelves W 54.5 - Dpt 26	154	Accessories for FLEXO walk-in closet	262	Groups with top and with top and base technical information	356
<b>General characteristics</b>	<b>11</b>	SUMMER end bookshelves W 53.9 - Dpt 21	155			OPTIONAL groups with top and with top and base	357
Colours	12	TWIG wardrobes Ht 184.2 - Dpt 56.3	156	<b>Bridge units - Corner bridge unit</b>	<b>265</b>	Groups with top	358
Fabrics and faux leathers	14	TWIG wardrobes Ht 216.2 - Dpt 56.3	158	RIALTO bridge unit Dpt 56.3 - technical information	266	Groups with top and base	359
Contrasting seams	18	Accessories for TWIG wardrobe Dpt 56.3	160	OPTIONAL for RIALTO bridge unit	268	POLDO bedside tables and baskets	360
Flame retardant coverings	20	Service furniture Dpt 72.3 - technical information	162	Wardrobes with shaped side panels Ht 225.6 - Dpt 56.3	270	BRICK group	361
Colors of wheels and methacrylates	21	Service furniture Dpt 72.3	164	Wardrobes with shaped side panels Ht 241.6 - Dpt 56.3	271	PODIO bench Dpt 49 - Ht 8	362
Colours (non-standard) for seats	22	Accessories for service furniture Dpt 72.3	166	Wardrobes with shaped side panels Ht 257.6 - Dpt 56.3	272	Bench Dpt 41 - Ht 10	362
ONE fronts	28			Accessories for wardrobe with shaped side panels Dpt 56.3	273	Mirror	363
CLUB fronts	30	<b>Container units hinged doors</b>	<b>169</b>	RIALTO bridge unit Ht 96 - Dpt 56.3	274	Single beds with headboard and footboard	364
WINDOW fronts	32	Container units - technical information	170	RIALTO bridge unit Ht 112 - Dpt 56.3	275	Single beds with ATLANTE bed frame	368
LINEAR sliding doors	34	OPTIONAL for Container units	172	RIALTO bridge unit Ht 128 - Dpt 56.3	276	Single beds with GIOVE bed frame	374
SECTOR and DIAGONAL sliding doors	36	Container units Ht 193.6 - Dpt 45	174	Accessories for RIALTO bridge unit Dpt 56.3	277	Single beds with MARTE bed frame	380
RIVIERA sliding doors	38	Container units Ht 225.6 - Dpt 45	176	RIALTO bridge unit Ht 96 - Dpt 56.3 with oblique cut doors	278	Single beds with NETTUNO bed frame	382
INSERTO sliding doors	40	Container units Ht 257.6 - Dpt 45	179	RIALTO bridge unit W 210 - Dpt 56.3 with bellow doors	279	Single beds with SIGMA bed frame	384
Custom cuts	42	Filler strip 5.4 - 5.4 (for empty corners)	182	RIALTO corner bridge unit Dpt 56.3	280	Single beds with metal bed frame	386
Filler strips	44	SMART end bookshelf W 43.2 - Dpt 26	183	Over-bar wardrobe for RIALTO bridge unit Dpt 56.3	282	Single beds with somier	388
		Accessories for Container units Dpt 45	184	Elements for RIALTO bridge unit Dpt 56.3	284	Padded single beds	390
<b>Accessories, Single doors, Chairs and Tables</b>	<b>47</b>	End units Dpt 45 - W 45	186			Padded single beds ECOCHIC	392
Knobs and handles	48	Container units Ht 193.6 - Dpt 32.5	188	<b>Loft beds - Bunk beds</b>	<b>287</b>	Single ottomans with headboard and footboard	394
Knob and handle positions	56	Container units Ht 225.6 - Dpt 32.5	190	Loft beds - technical information	288	Sofa beds	398
Colour sample sets and paints for repairs	60	Container units Ht 257.6 - Dpt 32.5	192	OPTIONAL for Loft beds	290	Bed and sofa bed with second automatic lifting base	400
Panels and edges	61	Accessories for Container units Dpt 32.5	194	KINTAI loft beds Dpt 93.3	292	BAIA sofa beds and desks	402
Hardware	62			IRON loft beds Ht 225.6	296	Accessories for beds	404
Miscellaneous	64	<b>Wardrobes sliding doors</b>	<b>197</b>	IRON loft beds Ht 241.6	298		
Lighting	65	Wardrobes with sliding doors - technical information	198	IRON loft beds Ht 257.6	300	<b>Desks - Shaped tops</b>	<b>407</b>
Tables and coffee tables	66	OPTIONAL for wardrobes with sliding doors	200	CREEK loft beds	302	Desks - technical information	408
Chairs and armchairs for study area	68	Wardrobes Dpt 61.5 with LINEAR sliding doors W 90	202	HELIX loft beds	304	OPTIONAL for desks	409
Doors	70	Wardrobes Dpt 61.5 with SECTOR sliding doors W 90 and 135	204	Side support panels for Loft beds	306	Holes for built-in technology	410
Doors for over-bar wardrobe of RIALTO bridge unit	76	Wardrobes Dpt 61.5 with DIAGONAL and SECTOR sliding doors W 135	206	Accessories for Loft beds	307	Desks with POLDO shaped top Ht 77.6 - Dpt 60	412
Door panel without holes for hinges and handles	77	Wardrobes Dpt 61.5 with RIVIERA sliding doors W 90 and 135	208	FORMENTERA bunk bed Ht 184.6 - W 200 - Dpt 88.3	308	Desks with SG100 shaped top Ht 77.6 - Dpt 65	416
Drawers and big drawers	78	Wardrobes Dpt 61.5 with INSERTO sliding doors W 90 and 135	209	SPRINT bunk beds	310	Desks with SG101 shaped top Ht 77.6 - Dpt 65	421
		Accessories for wardrobes with sliding doors	210	SLOT bunk beds bed base W 80	312	Desks with SG102 shaped top Ht 77.6 - Dpt 65	426
<b>Wardrobes hinged doors</b>	<b>83</b>			SLOT bunk beds bed base W 90	313	Corner desks with SG500 shaped top Ht 77.6	430
Wardrobes - technical information	84	<b>Walk-in wardrobes</b>	<b>215</b>	OSLO bunk beds	314	Peninsulas with SG200 shaped top Ht 77.6 - Dpt 65	432
OPTIONAL for wardrobes	86	Walk-in wardrobes - technical information	216	Metal ladders and guards for Loft beds and Bunk beds	315	Peninsulas with SG201 shaped top Ht 77.6 - Dpt 65	433
Made-to-measure solutions for hinged doors	88	OPTIONAL for walk-in wardrobes	218	MARGOT container ladder with shaped sides	316	Peninsulas with SG400, SG401 and SG402 shaped tops Ht 77.6	434
Wardrobes Ht 193.6 - Dpt 56.3	90	Made-to-measure gaps for walk-in wardrobe	220	GRETA container ladder with shaped sides with PLATFORM	317	Shaped tops and bases H 75.1 for desks and peninsulas	436
Wardrobes Ht 193.6 - Dpt 56.3 - with niche	94	SMALL walk-in wardrobes Dpt 56.3 - W 98.7 x 98.7	222	CLIVIA container ladder with shaped sides	320	LINEA writing desks with unfinished back panel Ht 77.6 - Dpt 57.1/45.8	438
Wardrobes Ht 225.6 - Dpt 56.3	96	BIG walk-in wardrobes Dpt 56.3 - W 119.9 x 119.9	224	DALIA container ladder with shaped sides	321	ANCORA desks Ht 77.6 - Dpt 60	440
Wardrobes Ht 225.6 - Dpt 56.3 - with niche	100	LARGE walk-in wardrobes Dpt 56.3 - W 98.7 x 140.5	226	HAPPY equipped bunk bed, bed base W 90	322	TWIG desks Ht 77.6 - Dpt 60	441
Wardrobes Ht 241.6 - Dpt 56.3	102	LARGE walk-in wardrobes Dpt 56.3 - W 98.7 x 150.5	228	HAPPY equipped bunk bed, bed base W 90 L-SHAPED	324	FLY desks Ht 77.6 - Dpt 57.1	442
Wardrobes Ht 241.6 - Dpt 56.3 - with niche	106	Accessories for walk-in wardrobes	230	HAPPY equipped bunk bed, bed base W 90 WITH WALK-IN WARDROBE	325	LOFT desks Ht 75 - Dpt 59.7	443
Wardrobes Ht 257.6 - Dpt 56.3	108	SMALL walk-in wardrobe with the universal gap	232	HAPPY single beds, bed base W 90	326	ROUND desks Ht 72 - Dpt 45.6	443
Wardrobes Ht 257.6 - Dpt 56.3 - with niche	112	BIG walk-in wardrobe with the universal gap	233	Accessories for HAPPY	327	PODIO desks Dpt 49	444
Wardrobes Ht 289.6 - Dpt 56.3	114	LARGE walk-in wardrobe W 140.5 with the universal gap	234			EVO desk Ht 90,5 - Dpt 50	445
Wardrobe compositions Dpt 56.3	118	LARGE walk-in wardrobe W 150.5 with the universal gap	235	<b>Space-saving systems</b>	<b>329</b>	BAIA desk Ht 99.3 - Dpt 54	445
Wardrobes Dpt 56.3 with fixed TV stand element	124	Accessories for walk-in wardrobes with the universal gap	236	CLICK foldaway beds with W 80 base	330	Custom-made shaped tops WITHOUT HOLES for assembly	446
Wardrobes Dpt 56.3 with openable TV stand element	126			CLICK foldaway beds with W 120 base	332	Designed shaped panels Th 2.5	448
Wardrobes Dpt 56.3 with pull-out desk	128	<b>FLEXO walk-in closet</b>	<b>239</b>	CLICK foldaway beds with W 140 base	333	Desk accessories	450
Over-door wardrobe Dpt 56.3	130	FLEXO walk-in closet - technical information	240	CLICK foldaway beds with W 160 base - (A)	334		
Accessories for wardrobe Dpt 56.3	132	FLEXO walk-in closet Ht 193.6	242	CLICK foldaway beds with W 160 base - (B)	338	<b>Shelves, Cubes and Boiserie</b>	<b>453</b>
Corner wardrobe units Dpt 56.3 - W 99.6 x 101.3	136	FLEXO walk-in closet Ht 193.6 - corner units	244	CLICK tables	339	Shelves Th 2.5	454
Corner wardrobes Dpt 56.3 - W 90 with opening door W 45	138	FLEXO walk-in closet Ht 225.6	246	MULTIFUNCTION wheeled beds with W 80 base	340	Shelves in frosted silk-screened glass Th 1	456
Corner wardrobes Dpt 56.3 - W 90 with opening door W 60	140	FLEXO walk-in closet Ht 225.6 - corner units	248	MULTIFUNCTION wheeled beds with W 90 base	342	PODIO shelves Dpt 24 - Th 5.5	456
External corner wardrobes Dpt 56.3 - W 56.3	142	FLEXO walk-in closet Ht 241.6	250	MUVI wheeled beds with W 80 base	344	Shelf holders and accessories	457
Filler strip 5.4 - 5.4 (for empty corners)	144	FLEXO walk-in closet Ht 241.6 - corner units	252	GRETA container ladder with shaped sides	346	CUBOLOTTA	458
End units Dpt 56.3 - W 40	146	FLEXO walk-in closet Ht 257.6	254	MULTIFUNCTION and MUVI bed guards	347	TEMA	458

# General table of contents

SCHEMA	459	Modular components for wardrobe room Ht 225.8 Dpt 59.5	564	PODIO desks and shelves	704	<b>INFINITY bookcases - Suspended</b>	<b>809</b>
MODO	459	Modular components for wardrobe room Ht 241.8 Dpt 59.5	565	Home office - technical information	706	Suspended Bookcases Dpt 33.3 - Dimensions	810
JOINT	460	Modular components for wardrobe room Ht 257.8 Dpt 59.5	566	Home office - Modular units Dpt 45	708	Suspended Bookcases Dpt 33.3 - Linear assembling	811
ALBATROS	460	Modular components for wardrobe room Ht 289.8 Dpt 59.5	567	Home office - Desks	710	Suspended Bookcases Dpt 33.3 - For top	812
PARALLEL	461	Central walk-in wardrobes for wardrobe room Dpt 59.5	568			Suspended Bookcases Dpt 33.3 - With top finishing insert	814
CLIO	461	End walk-in wardrobes for wardrobe room Dpt 59.5	570			Suspended Bookcases Dpt 33.3 - EASY	816
JIB	462					Suspended Bookcases maxi Dpt 33.3 - For top	818
ORIZZONTE	462	<b>Groups and Double beds</b>	<b>573</b>	<b>UP &amp; UP bookshelves</b>	<b>713</b>	Suspended Bookcases maxi Dpt 33.3 - With top finishing insert	819
PEPITA boiserie system	464	Groups	574	UP & UP bookshelf - Technical information	714	Suspended Bookcases maxi Dpt 33.3 - Dividing panels	820
DARSENA boiserie system	470	Mirrors	581	UP & UP bookshelf - Hanging and shelf	715	Suspended Bookcases Dpt 33.3 - Semi-suspended	822
		PODIO desks and shelves	582	UP & UP bookshelf - Examples of compositions	716	Suspended Bookcases Dpt 33.3 - Overhead units	826
<b>Modular wardrobes</b>	<b>479</b>	PODIO bench Dpt 49 - Ht 8	583			Suspended corner Bookcases Dpt 33.3 - Full corner	827
Side panel hole layout	480	Bench Dpt 41 - Ht 10	583	<b>INFINITY bookcases</b>	<b>719</b>	Suspended Bookcases Dpt 33.3 - For top with TV compartment	828
STYLE fronts Th 1.8	482	Double bed - technical information	584	INFINITY bookcases - Introduction	720	Suspended Bookcases Dpt 33.3 - With TV compartment and top finishing insert	830
CONCRETA fronts Th 2.5	483	Double beds	586	INFINITY bookcases - The structure	722	DOCKS modular units for bookcases INFINITY Dpt 33.3	832
CUTTING fronts Th 2.5	484	Double beds with rear housing space	592	INFINITY bookcases - Technical information	724	MAGIC modular units suspended for bookcases INFINITY Dpt 33.3	834
CUTTING PLUS fronts Th 2.5	485	Double beds with metal bed frame	596	INFINITY bookcases - TV compartments	726	GOLF product data sheet	838
WINDOW fronts Th 2.1	486	Double beds with SIGMA bed frame	597	INFINITY bookcases - Rotating 180° TV compartment	728	General conditions of sale	840
STYLE sliding doors Th 1.8	488	Padded double beds	598	INFINITY bookcases - Minimum distances for assembling	729		
MOSAICO sliding doors Th 1.8	489	UNIQUE padded double bed	600	INFINITY bookcases - Lighting	730		
FREEDOM sliding doors Th 1.8	490	DARSENA padded double bed	601	INFINITY bookcases - Customized cuts	731		
CONCRETA sliding doors Th 2.5	491	Padded double beds ECOCHIC	602	INFINITY doors	732		
RAIL sliding doors Th 2.5/1.8	492	Accessories for double beds	608	INFINITY doors for full corner	734		
CUTTING sliding doors Th 2.5	493			INFINITY doors vasistas and folding Ht 32	734		
Handles	494	<b>Modular units, Wall units and Sideboards</b>	<b>611</b>	Drawers INFINITY	735		
Handle positions	496	Modular units and wall units - Technical information	612	Inside drawers INFINITY	735		
Hinged doors	498	OPTIONAL for modular units and wall units	614	Sliding doors INFINITY	736		
Custom cuts	500	Floor/support Modular units Dpt 56.3	616				
Filler strips for modular wardrobes	502	L corner Modular units Dpt 56.3 - W 90	626	<b>INFINITY bookcases - Self standing</b>	<b>739</b>		
Hardware	503	R corner Modular units Dpt 56.3 - W 90	627	Self standing bookcases Dpt 33.3 - Dimensions	740		
Accessories for modular wardrobes	504	Floor/support Modular units Dpt 45	628	Self standing bookcases Dpt 33.3 - Linear assembling	742		
Power adapters and switches	510	L corner Modular units Dpt 45 - W 90	638	Self standing bookcases Dpt 33.3	744		
		R corner Modular units Dpt 45 - W 90	639	Self standing bookcases Dpt 33.3 - Ht 195.3	746		
<b>Modular wardrobes - Hinged doors</b>	<b>513</b>	Floor/support Modular units Dpt 32.5	640	Self standing bookcases Dpt 33.3 - Ht 227.3	748		
Wardrobes - technical information	514	L corner Modular units Dpt 32.5 - W 90	650	Self standing bookcases Dpt 33.3 - Ht 259.3	750		
Made-to-measure solutions for hinged doors	516	R corner Modular units Dpt 32.5 - W 90	651	Self standing bookcases maxi Dpt 33.3	752		
Modular components Ht 225.8	518	Hanging Modular units Dpt 45	652	Self standing bookcases maxi Dpt 33.3 - Dividing panels	754		
Modular components Ht 241.8	520	Hanging Modular units Dpt 32.5	656	Self standing bookcases Dpt 33.3 - Semi-suspended	756		
Modular components Ht 257.8	522	Wall units Dpt 32.5	660	Self standing corner bookcases Dpt 33.3 - Full corner	764		
Modular components Ht 289.8	524	Tops and bases for modular units and wall units	662	Self standing end-bookcases Dpt 33.3	765		
Modular wardrobes	526	Adjustable feet for modular units	666	Self standing bookcases Dpt 33.3 - For passage	766		
Overhead wardrobes - technical information	528	ROUND desk Ht 72 - Dpt 45.6	667	Floor boiserie	768		
Overhead wardrobes compositions	530	Accessories for modular units and wall units	668	Semi-suspended boiserie	770		
Wardrobes with niche	531	Sideboards Dpt 45.6 with outer box Th 1.8	670	Self standing bookcases Dpt 33.3 - With desk	772		
Wardrobes with console	532	Sideboards Dpt 45.8 with outer box Th 2.5	678	Self standing bookcases Dpt 33.3 - With peninsula	774		
Wardrobes with TV mount	533	Accessories for sideboards with outer box	686	Self standing bookcases Dpt 33.3 - With TV compartment	776		
		INSIDE sideboards Dpt 54	687	Self standing bookcases Dpt 33.3 - With 180° rotating TV compartment	778		
<b>Modular wardrobes - Sliding doors</b>	<b>535</b>			Self standing bookcases Dpt 33.3 - With CLICK foldaway beds W 80 base	780		
Wardrobes with sliding doors - technical information	536	<b>Hotel - Contract markets - Home office</b>	<b>689</b>	Self standing bookcases Dpt 33.3 - With CLICK foldaway beds W 120 base	782		
Wardrobes with STYLE sliding doors Th 1.8	538	BASIC continuous headboards profile 3 x 5	690	Self standing bookcases Dpt 33.3 - With CLICK foldaway beds W 140 base	783		
Wardrobes with MOSAICO sliding doors Th 1.8	544	SUPERIOR continuous headboards profile 7 x 5	691	Self standing bookcases Dpt 33.3 - With CLICK foldaway beds W 160 base - (A)	784		
Wardrobes with FREEDOM sliding doors Th 1.8	548	Continuous headboards	692	Self standing bookcases Dpt 33.3 - With CLICK foldaway beds W 160 base - (B)	788		
Wardrobes with CONCRETA sliding doors Th 2.5	550	MUSHY continuous headboard	693	Self standing bookcases Dpt 45.8 - Dimensions	790		
Wardrobes with RAIL sliding doors Th 1.8/2.5	552	Beds	694	Self standing bookcases Dpt 45.8 - Linear assembling	791		
Wardrobes with CUTTING sliding doors Th 2.5	554	STICK bedside tables Dpt 45.8	696	Self standing bookcases Dpt 45.8	792		
		PODIO bench Dpt 49 - Ht 8	697	Self standing bookcases Dpt 45.8 - Ht 195.3	794		
<b>Modular wardrobes - Walk-in wardrobes</b>	<b>557</b>	Bench Dpt 41 - Ht 10	697	Self standing bookcases Dpt 45.8 - Ht 227.3	796		
Walk-in wardrobes - technical information	558	Wardrobes Dpt 56.3	698	Self standing bookcases Dpt 45.8 - Ht 259.3	798		
Components for wardrobe room - technical information	559	Suitcase holder	700	Self standing corner bookcases Dpt 45.8 - Full corner	800		
Central walk-in wardrobes	560	STICK suitcase holder	701	Self standing end-bookcases Dpt 45.8	801		
End walk-in wardrobes	562	Mini-bar cabinets and writing desks with unfinished back panel	702	Self standing bookcases Dpt 45.8 - For passage	802		
				Self standing bookcases Dpt 45.8 - With peninsula	804		
				Self standing bookcases Dpt 45.8 - With TV compartment	806		

**GROUP 1 colors**

**GROUP 2 colors**

**GROUP 3 colors**

**CARCASE colors**

Rovere Dorian <b>RD5T</b>	Rovere white <b>RW3Q</b>	Noce naturale <b>NN7H</b>	Eucalipto <b>CL1X</b>	Domy <b>DM7P</b>	Bianco UV <b>BU3Q</b>
Ciliegio bianco <b>CB6K</b>	Malta <b>ML7H</b>	Feltro <b>FL8X</b>	Cemento Masdar <b>CM3Q</b>	Blu indaco <b>BI4B</b>	
Noce <b>NC4B</b>	Desert <b>DS9L</b>	Canapa <b>CN1X</b>	Moka <b>MK6B</b>	Cipria <b>CP4J</b>	
Bianco opaco <b>BI7A</b>	Grigio Dorian <b>GL4R</b>	Basalto <b>BS5T</b>	Grigio titanio <b>GZ8T</b>	Rosa bubble <b>RB7Y</b>	
	Agave <b>GV7A</b>	Verde Alpi <b>VA5T</b>	Cadaques <b>CQ3Q</b>	Giallo zafferano <b>GZ8A</b>	
	Blu opale <b>BO7H</b>			Corallo <b>CR5T</b>	

**Types and colors FRONT**

**ONE**

matte

glossy

**CLUB**

Specify the color of the CLUB handle

**WINDOW**

Specify the color of the aluminum frame

Rovere white <b>RW3Q</b>	Rovere Dorian <b>RD5T</b>	Ciliegio bianco <b>CB6K</b>	Noce naturale <b>NN7H</b>	Noce <b>NC4B</b>	Eucalipto <b>CL1X</b>	Malta <b>ML7H</b>
Feltro <b>FL8X</b>	Cemento Masdar <b>CM3Q</b>	Bianco opaco <b>BI7A</b>	Desert <b>DS9L</b>	Canapa <b>CN1X</b>	Moka <b>MK6B</b>	Grigio Dorian <b>GL4R</b>
Basalto <b>BS5T</b>	Grigio titanio <b>GZ8T</b>	Domy <b>DM7P</b>	Agave <b>GV7A</b>	Verde Alpi <b>VA5T</b>	Cadaques <b>CQ3Q</b>	Blu indaco <b>BI4B</b>
Blu opale <b>BO7H</b>	Cipria <b>CP4J</b>	Rosa bubble <b>RB7Y</b>	Giallo zafferano <b>GZ8A</b>	Corallo <b>CR5T</b>		

Bianco opaco <b>BI7A</b>	Desert <b>DS9L</b>	Canapa <b>CN1X</b>	Moka <b>MK6B</b>	Grigio Dorian <b>GL4R</b>	Basalto <b>BS5T</b>	Grigio titanio <b>GZ8T</b>
Domy <b>DM7P</b>	Agave <b>GV7A</b>	Verde Alpi <b>VA5T</b>	Cadaques <b>CQ3Q</b>	Blu indaco <b>BI4B</b>	Blu opale <b>BO7H</b>	Cipria <b>CP4J</b>
Rosa bubble <b>RB7Y</b>	Giallo zafferano <b>GZ8A</b>	Corallo <b>CR5T</b>				

Trasparente <b>TR9M</b>	Trasparente fumé <b>FT8P</b>	Stop-sol <b>ST6P</b>	Specchio <b>SP7L</b>
----------------------------	---------------------------------	-------------------------	-------------------------

Alluminio <b>AL1A</b>	Titan grey <b>TG7H</b>
--------------------------	---------------------------

**General characteristics**

Colours	12
Fabrics and faux leathers	14
Contrasting seams	18
Flame retardant coverings	20
Colors of wheels and methacrylates	21
Colors (non-standard) for seats	22
ONE fronts	28
CLUB fronts	30
WINDOW fronts	32
LINEAR sliding doors	34
SECTOR and DIAGONAL sliding doors	36
RIVIERA sliding doors	38
INSERTO sliding doors	40
Custom cuts	42
Filler strips	44



# Colours

Melamine-coated panel

 <p>Rovere white <b>RW3Q</b></p>	 <p>Rovere Dorian <b>RD5T</b></p>	 <p>Ciliegio bianco <b>CB6K</b></p>	 <p>Noce naturale <b>NN7H</b></p>
 <p>Noce <b>NC4B</b></p>	 <p>Eucalipto <b>CL1X</b></p>	 <p>Malta <b>ML7H</b></p>	 <p>Feltro <b>FL8X</b></p>
 <p>Cemento Masdar <b>CM3Q</b></p>	 <p>Bianco opaco <b>BI7A</b></p>	 <p>Desert <b>DS9L</b></p>	 <p>Canapa <b>CN1X</b></p>
 <p>Moka <b>MK6B</b></p>	 <p>Grigio Dorian <b>GL4R</b></p>	 <p>Basalto <b>BS5T</b></p>	 <p>Grigio titanio <b>GZ8T</b></p>

Glasses and mirror

 <p>Domy <b>DM7P</b></p>	 <p>Agave <b>GV7A</b></p>	 <p>Verde Alpi <b>VA5T</b></p>	 <p>Cadaques <b>CQ3Q</b></p>
 <p>Blu indaco <b>BI4B</b></p>	 <p>Blu opale <b>BO7H</b></p>	 <p>Cipria <b>CP4J</b></p>	 <p>Rosa bubble <b>RB7Y</b></p>
 <p>Giallo zafferano <b>GZ8A</b></p>	 <p>Corallo <b>CR5T</b></p>	 <p>Bianco UV <b>BU3Q</b></p>	
 <p>Trasparente <b>TR9M</b></p>	 <p>Trasparente fumé <b>FT8P</b></p>	 <p>Stop-sol <b>ST6P</b></p>	 <p>Specchio <b>SP7L</b></p>

General characteristics

✳ Finishing with textured effect  
 ✨ UV glossy finishing

# Fabrics and faux leathers

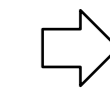

General characteristics



## RV24JN - JENNY fabric

### Material specifications:

Composition 100% polyester  
 Weight 375 gr/m<sup>2</sup>  
 Martindale 60,000

### Washing instructions:

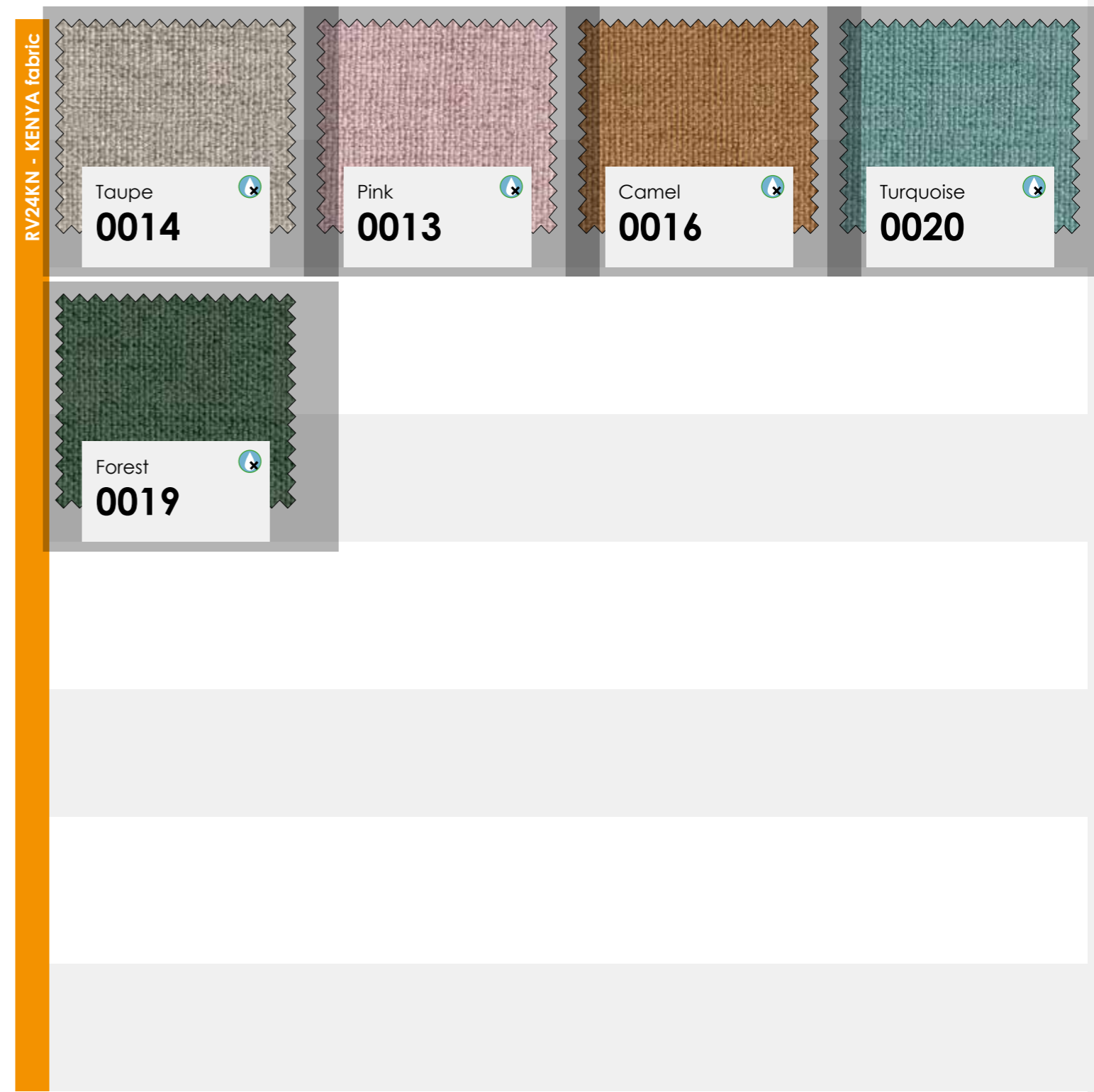

## RV24KN - KENYA fabric

### Material specifications:

Composition 100% polyester  
 Weight 434 gr/m<sup>2</sup>  
 Martindale > 100,000

### Washing instructions:



N.B. These indications are merely guidelines and are provided in good faith; they may not be considered binding in any circumstance.

### Water-repellent stain.

Thanks to this treatment, liquids or substances that may accidentally fall on the coating, will not penetrate into the fabric and will not be absorbed by the rubber in the cushion. In case you accidentally spill a watery solution (water, wine, coffee, soft drinks, etc.) it is enough to dry it with a dry cloth or paper towels. In the case the substance remains on the fabric for a prolonged amount of time or has suffered excessive pressure, after having been dried, you will need to rub gently with a damp non-abrasive sponge. In severe cases, you can use mild soap, subsequently rinse afterwards.



# Fabrics and faux leathers

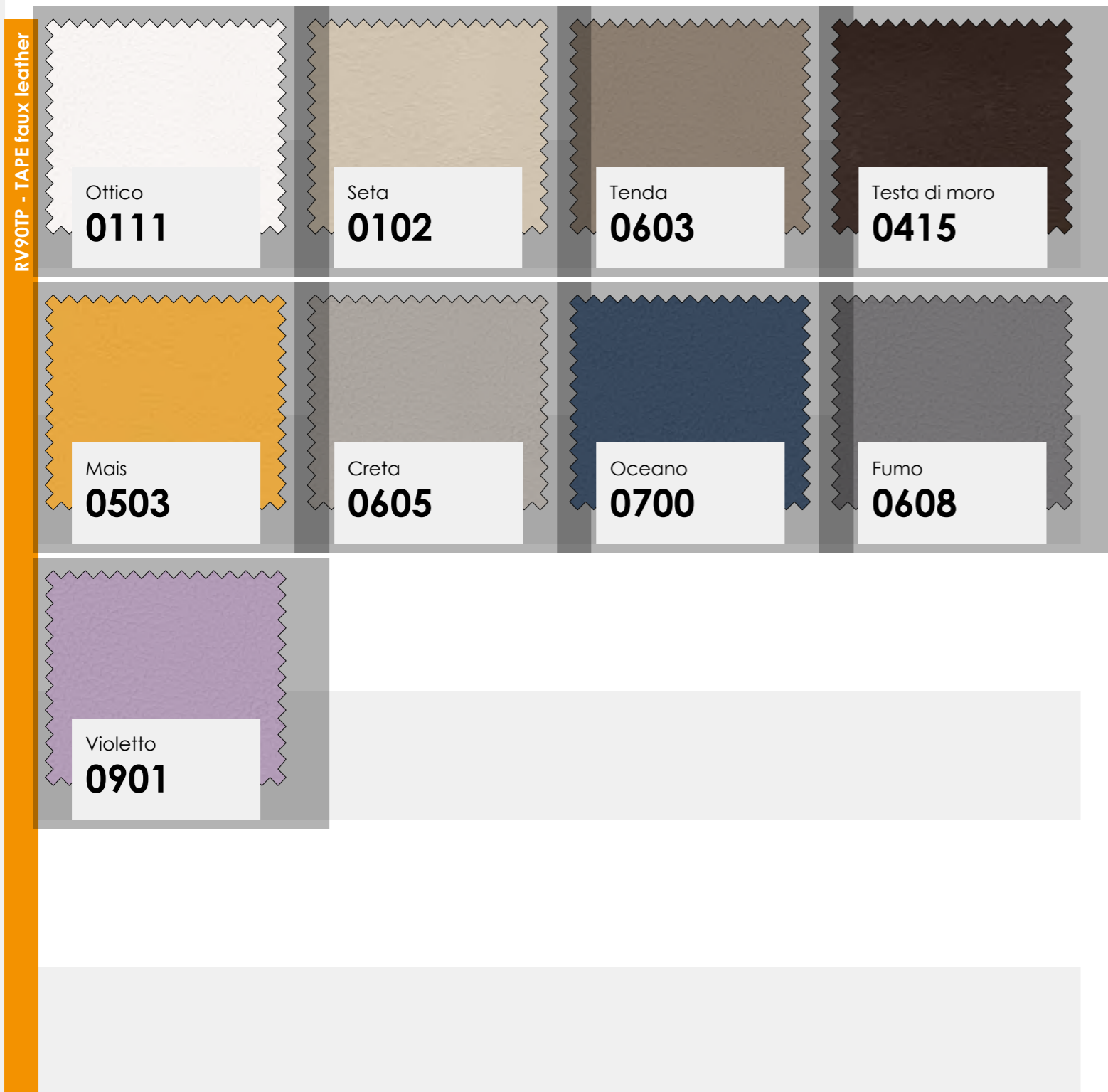

## RV90TP - TAPE faux leather

### Material specifications:

Composition	85% polyvinyl chloride 15% polyester
Weight	530 gr/m <sup>2</sup>
Martindale	> 100.000

### Fire resistance:

This product has been successfully tested according to the following methods:  
 · EN 1021-1:2006 & EN 1021-2:2006  
 · BS 5852-1 (UK) (1979)

### Washing instructions:

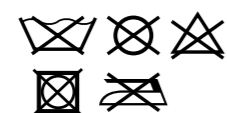

### Maintenance:

clean gently with damp, soft cloth.  
 Do not use abrasive and degreasing products or chemical detergents, which may ruin irremediably the upholstery.

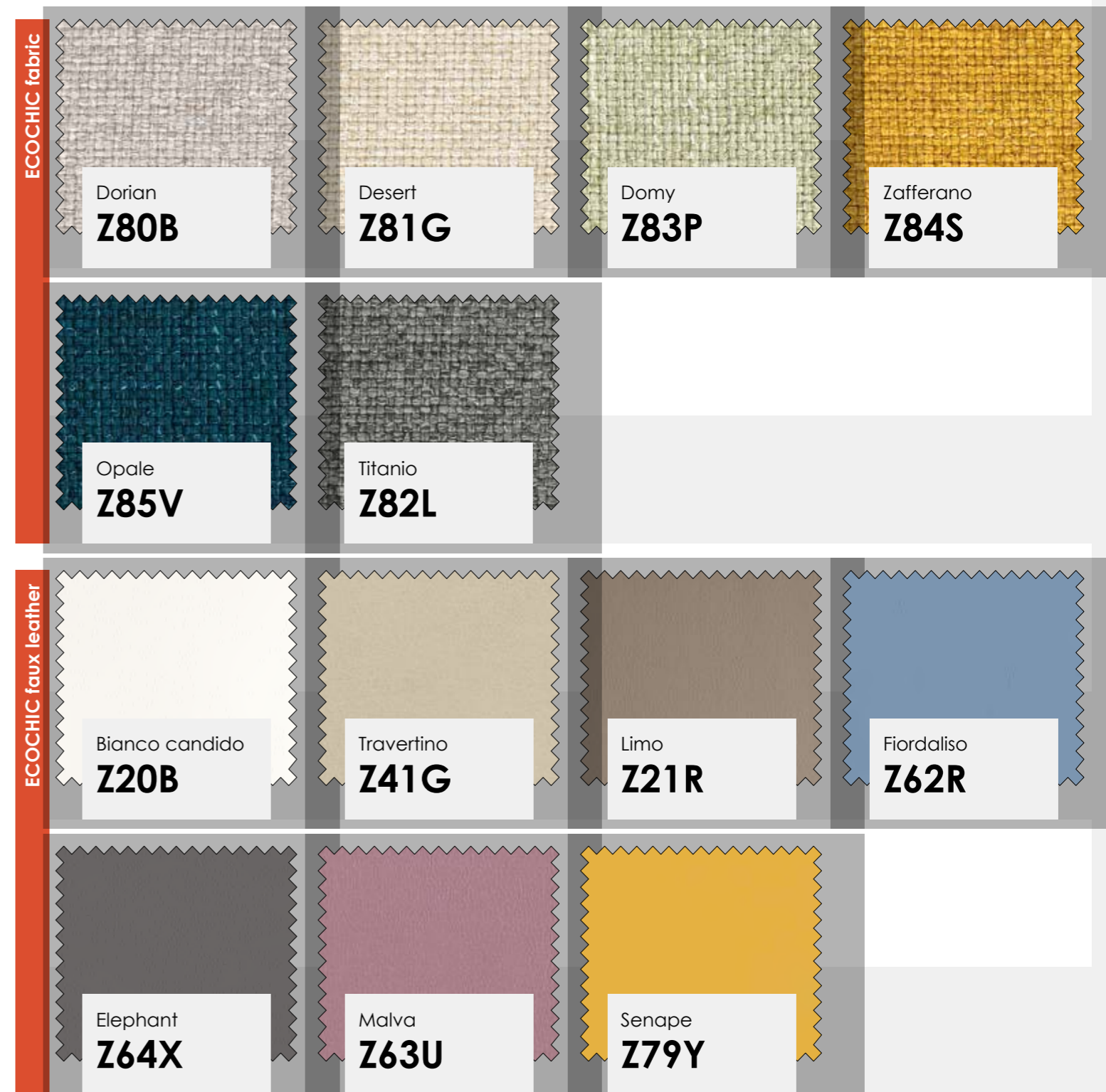

## ECOCHIC fabric

### Material specifications:

Composition	100% polyester
Weight	350 gr/m <sup>2</sup>
Martindale	> 100.000

### Washing instructions:



## ECOCHIC faux leather

### Material specifications:

Composition	100% polyester
Weight	190 gr/m <sup>2</sup>

### Washing instructions:

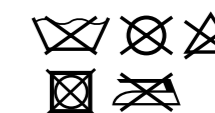

### Maintenance:

clean gently with damp, soft cloth.  
 Do not use abrasive and degreasing products or chemical detergents, which may ruin irremediably the upholstery.

N.B. These indications are merely guidelines and are provided in good faith; they may not be considered binding in any circumstance.

### Water-repellent stain.

Thanks to this treatment, liquids or substances that may accidentally fall on the coating, will not penetrate into the fabric and will not be absorbed by the rubber in the cushion. In case you accidentally spill a watery solution (water, wine, coffee, soft drinks, etc.) it is enough to dry it with a dry cloth or paper towels. In the case the substance remains on the fabric for a prolonged amount of time or has suffered excessive pressure, after having been dried, you will need to rub gently with a damp non-abrasive sponge. In severe cases, you can use mild soap, subsequently rinse afterwards.

# Contrasting seams

The price list includes beds covered in fabric or eco-leather with contrasting edges or cords. The summary tables below shows the possible choices for matching covering colours with finishing seams.



## BEDS: SLIM

FABRIC JENNY:	Cord colour options:	0020	0014
0402 Zinc	→ 0604 Greystone	Turquoise	→ Taupe
0403 Papyrus	→ 0604 Greystone	0019 Forest	→ 0014 Taupe
0503 Carioca	→ 0402 Zinc	<b>FAUX LEATHER TAPE:</b> Cord colour options:	
0900 Pill	→ 0402 Zinc	0111 Ottico	→ 0605 Creta
0903 Nox	→ 0402 Zinc	0102 Seta	→ 0603 Tenda
0905 Coriander	→ 0604 Greystone	0603 Tenda	→ 0102 Seta
0314 Strawberry	→ 0604 Greystone	0415 Testa di moro	→ 0605 Creta
0303 Bombay	→ 0604 Greystone	0503 Mais	→ 0111 Ottico
0805 Water green	→ 0402 Zinc	0605 Creta	→ 0608 Fumo
0706 Steel	→ 0402 Zinc	0700 Oceano	→ 0605 Creta
0704 Smoke	→ 0402 Zinc	0608 Fumo	→ 0605 Creta
0601 Grey	→ 0604 Greystone	0901 Violetto	→ 0111 Ottico
0604 Greystone	→ 0402 Zinc		
FABRIC KENYA:	Cord colour options:		
0014 Taupe	→ 0014 Taupe		
0013 Pink	→ 0014 Taupe		
0016 Camel	→ 0014 Taupe		

## BEDS: KISS - TETRIS

FABRIC ECOCHIC:	Cord colour options:
Z80B Dorian	→ Z82L Titanio
Z81G Desert	→ Z82L Titanio
Z83P Domy	→ Z81G Desert
Z84S Zafferano	→ Z81G Desert
Z85V Opale	→ Z81G Desert
Z82L Titanio	→ Z81G Desert
FAUX LEATHER ECOCHIC:	Cord colour options:
Z20B Bianco candido	→ Z41G Travertino
	→ Z64X Elephant
Z41G Travertino	→ Z20B Bianco cand.
	→ Z21R Limo
Z21R Limo	→ Z21R Limo
	→ Z41G Travertino
Z62R Fiordaliso	→ Z20B Bianco cand.
	→ Z64X Elephant

## BED: PAD

FABRIC ECOCHIC:	Edging colour options:		
Z64X Elephant	→ Z20B Bianco cand.		
	→ Z64X Elephant		
Z80B Dorian	→ Z80B Dorian		
	→ Z82L Titanio		
Z81G Desert	→ Z81G Desert		
	→ Z82L Titanio		
Z83P Domy	→ Z83P Domy		
	→ Z81G Desert		
Z84S Zafferano	→ Z84S Zafferano		
	→ Z81G Desert		
Z85V Opale	→ Z85V Opale		
	→ Z81G Desert		
Z82L Titanio	→ Z82L Titanio		
	→ Z81G Desert		
FAUX LEATHER ECOCHIC:	Edging colour options:		
Z20B Bianco candido	→ Z20B Bianco cand.		
	→ Z41G Travertino		
	→ Z64X Elephant		

- Red arrow: Cord
- Blue arrow: Cord + band (always of the same color)
- Green arrow: Edging



## Flame retardant coverings

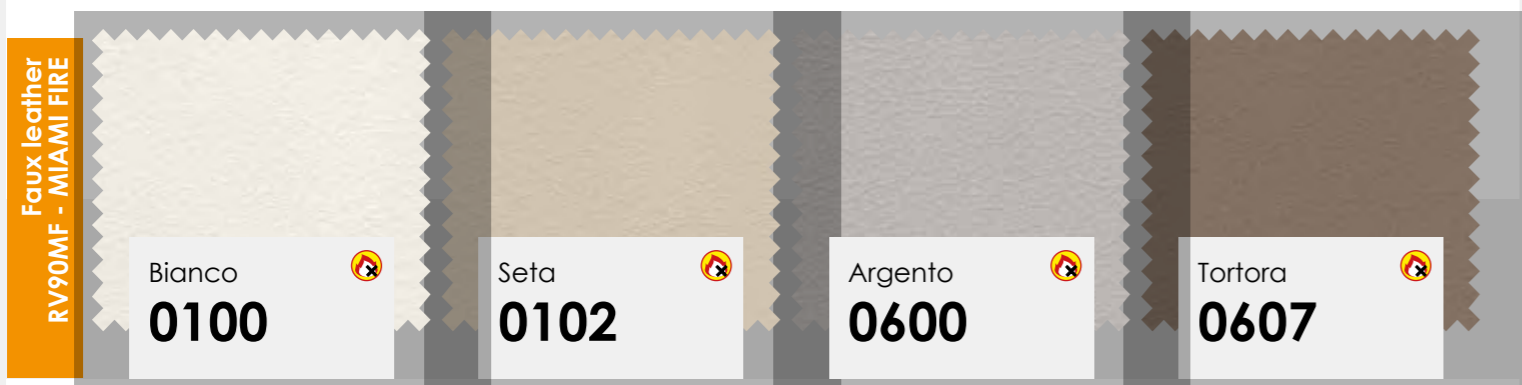

### Faux leather RV90MF - MIAMI FIRE

#### Material specifications:

Composition 50% PU - 17,5% CO - 32,5% PL  
 Weight 450 gr/m<sup>2</sup>  
 Martindale > 100.000

#### Washing instructions:



#### Fire resistance:

This product has been successfully tested according to the following methods:

- Classe 1 IM (UNI 9175)
- EN 1021-1:2006 & EN 1021-2:2006
- BS 5852-1 (Section 4, sources 0+1)

Colors may vary from lot to lot.

The producer reserves the right to modify, at any moment and without notice, the technical specifications of their products.

**Maintenance:** Clean gently with damp, soft cloth. Do not use abrasive and degreasing products or chemical detergents, which may ruin irremediably the upholstery.

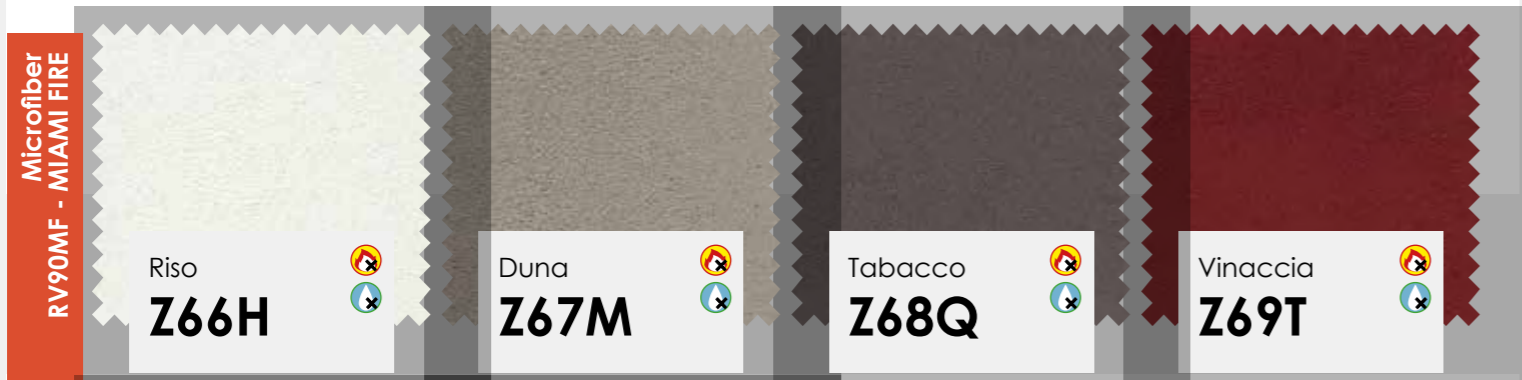

### Microfiber RV90MF - MIAMI FIRE

#### Material specifications:

Composition 100% PL  
 Weight 350 ± 5% gr/m<sup>2</sup>  
 Martindale > 40.000

#### Washing instructions:



#### Fire resistance:

This product has been successfully tested according to the following methods:

- Classe 1 IM (UNI 9175)
- EN 1021-1:2006 & EN 1021-2:2006
- BS 5852 PART 0 & 1:1979
- CRIB 5 BS 5852:2006

Colors may vary from lot to lot.

The producer reserves the right to modify, at any moment and without notice, the technical specifications of their products.

At the time of unpacking or following incorrect use, may display visible blotches or lines caused by crushed fibres. Use a brush with soft bristles to return the cover to its original appearance.

## Colors of wheels and methacrylates

### Methacrylate

for wheel covers:  
 Small wheel Ø 6  
 Big wheel Ø 15

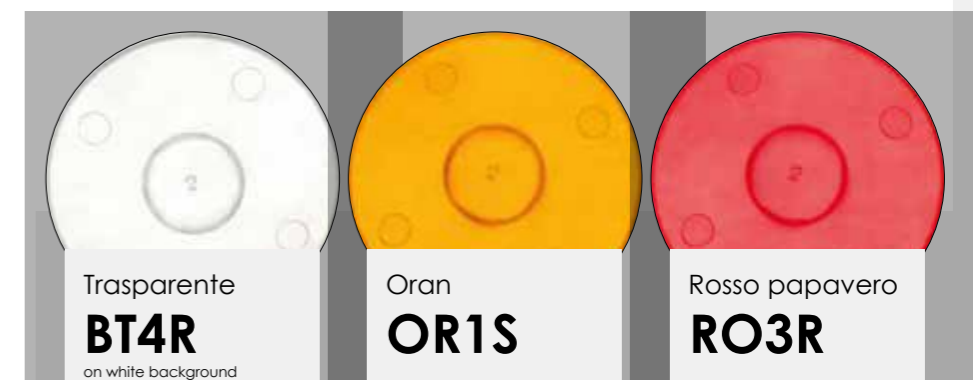
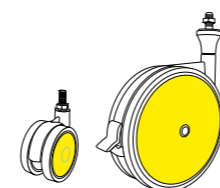

### Plastic

for wheel covers:  
 Small wheel Ø 6  
 Big wheel Ø 15

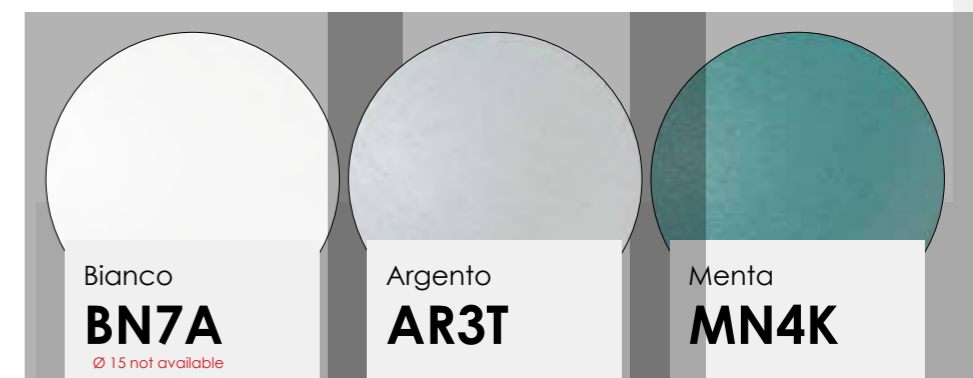
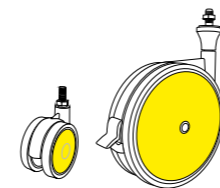

### Methacrylate

for Methacrylate guard

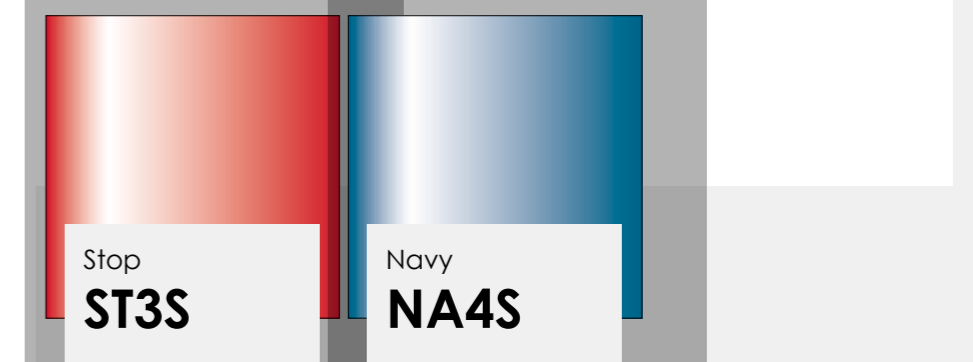
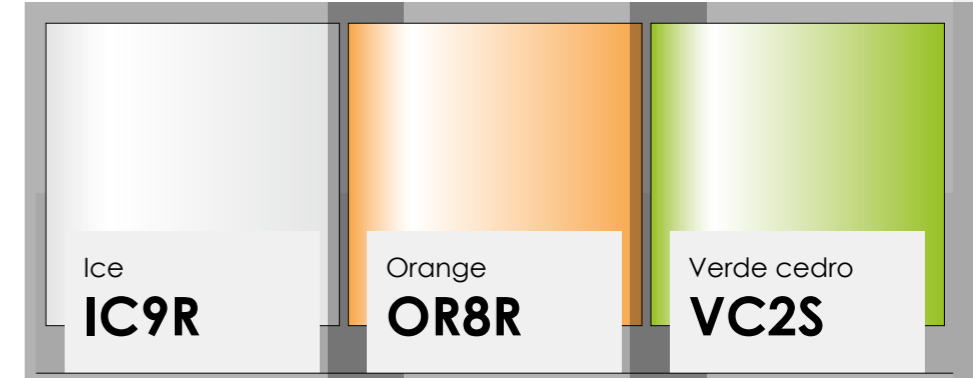
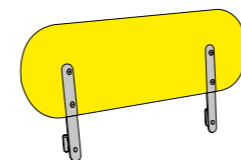

**N.B.** These indications are merely guidelines and are provided in good faith; they may not be considered binding in any circumstance.

Fireproof 1 CLASS (ONE)

Water-repellent stain.



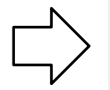

Thanks to this treatment, liquids or substances that may accidentally fall on the coating, will not penetrate into the fabric and will not be absorbed by the rubber in the cushion. In case you accidentally spill a watery solution (water, wine, coffee, soft drinks, etc.) it is enough to dry it with a dry cloth or paper towels. In the case the substance remains on the fabric for a prolonged amount of time or has suffered excessive pressure, after having been dried, you will need to rub gently with a damp non-abrasive sponge. In severe cases, you can use mild soap, subsequently rinse afterwards.



# Colours (non-standard) for seats

**Nylon**  
for BENNA chairs

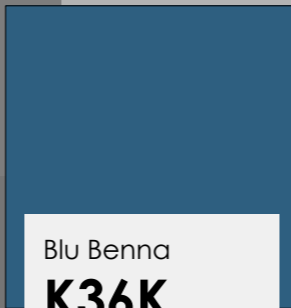

 Rosso Benna <b>K34C</b>	 Verde Benna <b>K35F</b>	 Blu Benna <b>K36K</b>	 Grigio Benna <b>K37N</b>
---	--	---	--



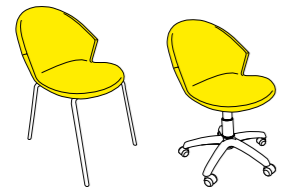



**Polypropylene**  
for BREDA chairs

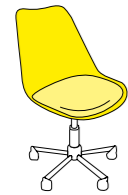

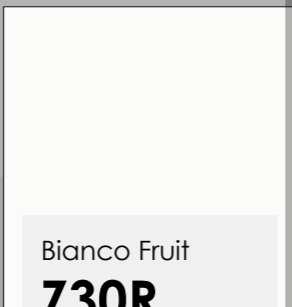
 Wit <b>K01P</b>	 Geel <b>K02S</b>	 Oranje <b>K03V</b>	 Rood <b>K04Y</b>	 Paars <b>K05B</b>	 Groen <b>K06E</b>	 Blauw <b>K07H</b>
---	---	--	--	---	---	---

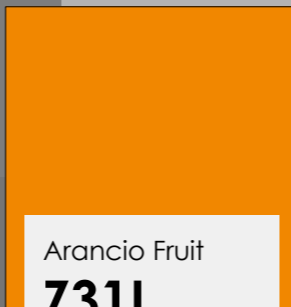
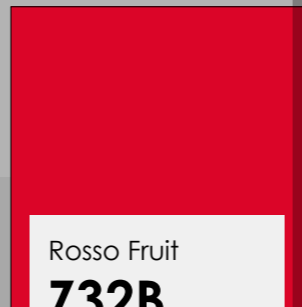
**Polypropylene**  
for FRUIT chair

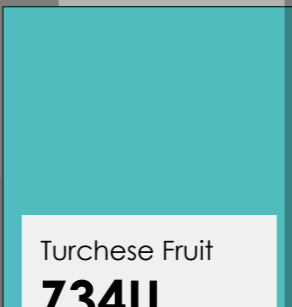
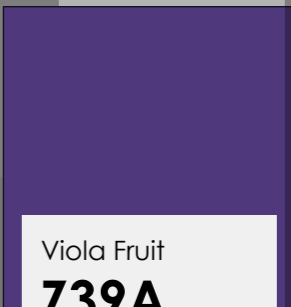

 Bianco Fruit <b>Z30R</b>	 Giallo Fruit <b>Z38R</b>	 Arancio Fruit <b>Z31L</b>	 Rosso Fruit <b>Z32B</b>	 Verde Fruit <b>Z33W</b>	 Turchese Fruit <b>Z34U</b>	 Viola Fruit <b>Z39A</b>	 Grigio Fruit <b>Z40T</b>
---	--	--	--	--	---	--	---

**Fabric**  
for GIROTONDO chair

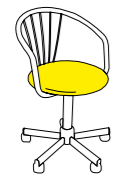

 Grigio <b>X22K</b>
--

**Polypropylene**  
for LUNA chairs



 Bianco Luna <b>K28F</b>	 Sabbia Luna <b>K29K</b>	 Rosso Luna <b>K30N</b>	 Grigio scuro Luna <b>K31T</b>
---	--	--	---

**Cushion cover**  
for LUNA chairs

 Grigio polvere <b>Z86Y</b>	 Porpora <b>Z87B</b>
--	---

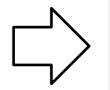

# Colours (non-standard) for seats

**Polypropylene**  
for NICE chair





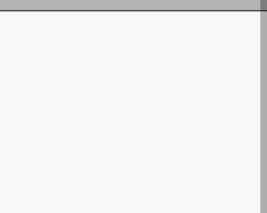
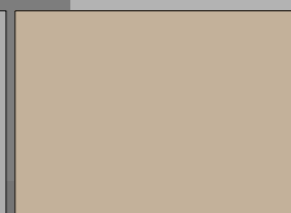
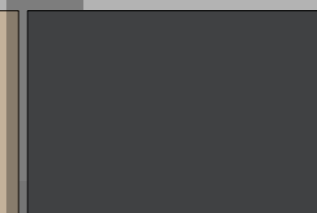

\* By ordering Sabbia Nice the chair will be two-coloured, with a white seat and back and a sand-coloured structure.

 Bianco Nice <b>K38R</b>	 Sabbia Nice * <b>K39U</b>	 Nero Nice <b>K40X</b>
---	--	---

**Faux leather**  
for SOFT chair

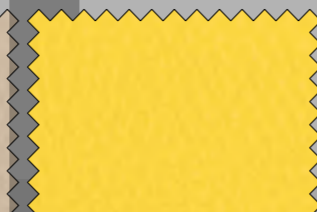

 Bianco Soft <b>Z24B</b>	 Beige Soft <b>Z25H</b>	 Giallo Soft <b>Z26N</b>	 Arancio Soft <b>Z27R</b>	 Viola Soft <b>Z28W</b>
---	---	---	--	--

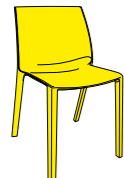

**Polypropylene**  
for STEP chair

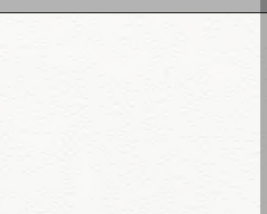
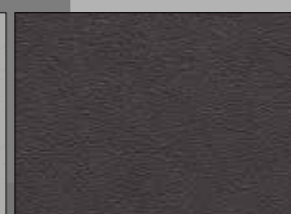

 Bianco Step <b>K32W</b>	 Nero Step <b>K33Z</b>
--	---

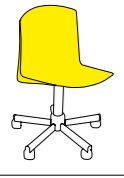
**Thermoformed polypropylene**  
for TRAK chair

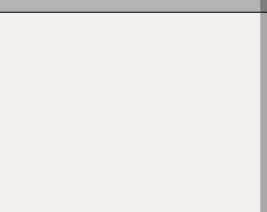
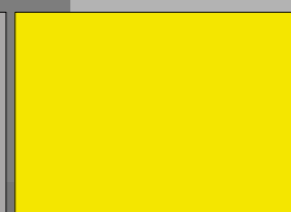

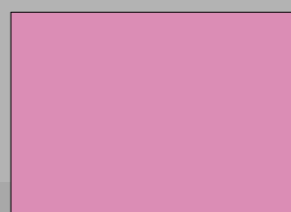
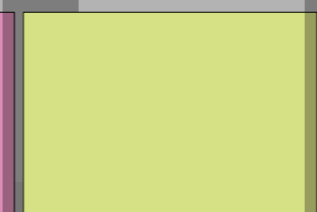
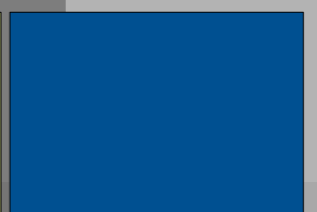
 Panna <b>Y33R</b>	 Limone <b>Z13K</b>	 Arancia <b>Z15L</b>	 Viola <b>Z14G</b>	 Verde eden <b>Z35F</b>	 Blu pervinca <b>Z16R</b>
---	---	---	---	--	--

**Faux leather**  
for WOODY chair

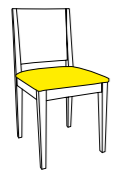

 Bianco Woody <b>Z56W</b>	 Canapa Woody <b>Z57T</b>	 Fango Woody <b>Z58R</b>	 Marrone Woody <b>Z59K</b>
--	---	---	---

# Colours (non-standard) for seats

**BERLIN fabric**  
for study chairs

Products made with flame retardant components.  
CLASS 1 IM UNI 9175/76





# ONE fronts

Colours available

<b>Rovere white RW3Q</b>	<b>Rovere Dorian RD5T</b>	<b>Ciliegio bianco CB6K</b>	<b>Noce naturale NN7H</b>	<b>Noce NC4B</b>	<b>Eucalipto CL1X</b>	<b>Malta ML7H</b>
<b>Feltro FL8X</b>	<b>Cemento Masdar CM3Q</b>	<b>Bianco opaco BI7A</b>	<b>Desert DS9L</b>	<b>Canapa CN1X</b>	<b>Moka MK6B</b>	<b>Grigio Dorian GL4R</b>
<b>Basalto BS5T</b>	<b>Grigio titanio GZ8T</b>	<b>Domy DM7P</b>	<b>Agave GV7A</b>	<b>Verde Alpi VA5T</b>	<b>Cadaques CQ3Q</b>	<b>Blu indaco BI4B</b>
<b>Blu opale BO7H</b>	<b>Cipria CP4J</b>	<b>Rosa bubble RB7Y</b>	<b>Giallo zafferano GZ8A</b>	<b>Corallo CR5T</b>		
<b>Bianco UV BU3Q</b>						

\* Finishing with textured effect  
\* UV glossy finishing  
\* Bianco UV (BU3Q) not available for Ht 288 doors.

Melamine-coated panel on both sides. In the UV glossy finish panels the internal side is matte.

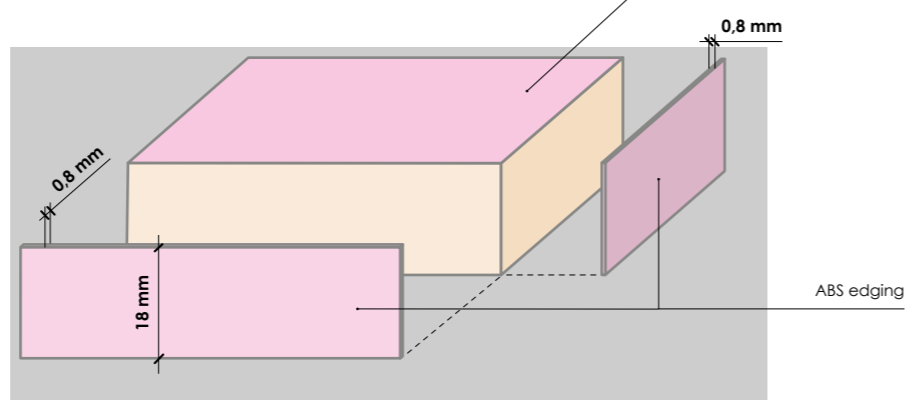

## Dimensions available

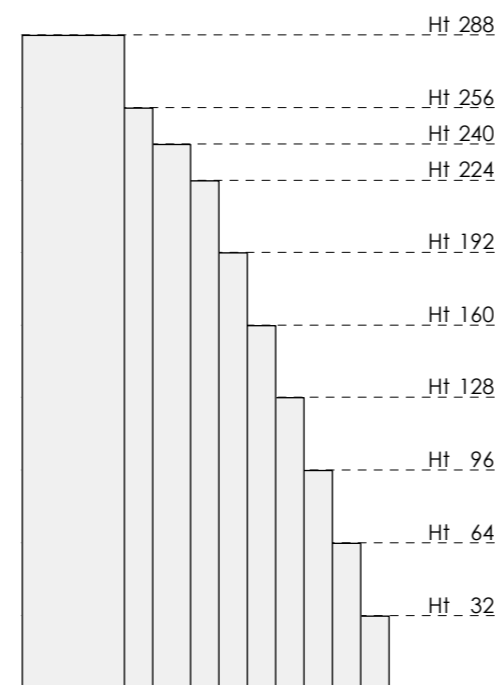

Doors W 30, 45 and 60

- Fitted with decelerated hinges.
- Upon request, can be supplied without a handle and without handle holes.

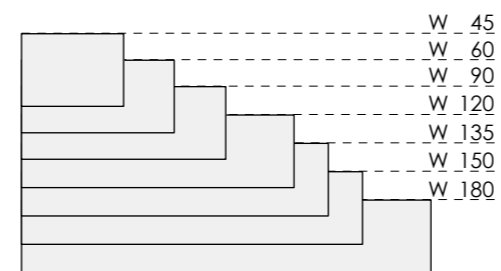

Flap and folding doors Ht 32

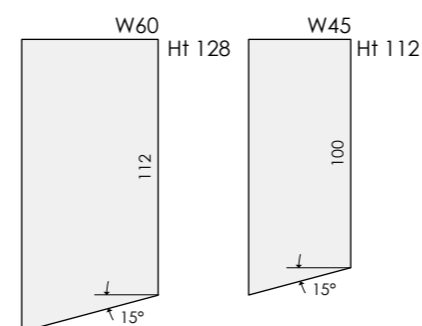

Doors with oblique cut

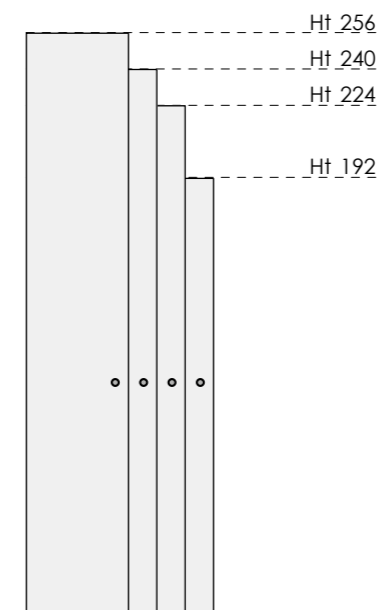
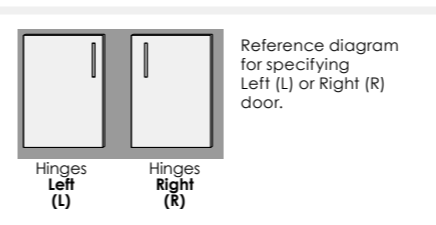

Doors with bar lock W 45 and 60

- Fitted with decelerated hinges.
- lock is always positioned at Ht 104. These locks have differentiated key biting.
- In elements W 90 and 120, the lock is always on the right-hand door.
- The left door has vertical dust catcher.
- They can only be installed on the ground.
- They can only be used on wardrobes.
- They are not fitted with handles or knobs.
- The keys supplied (2 in number) are always grey and folding.

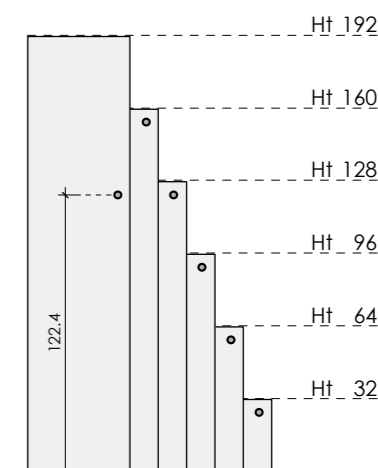

Doors with cylinder lock W 45 and 60

- Fitted with decelerated hinges.
- The locks have differentiated key biting.
- In elements W 90 and 120, the lock is always on the right-hand door.
- The keys supplied (2 in number) are always grey and folding.
- The door Ht 192 can only be installed on elements Dpt 45 and 32.5.
- They are always equipped with handles.
- It is not possible to apply the handles: **G86F - G75T - G82T - G49A.**

## Drawers/Big drawers

- Fitted with sliding, height-adjustable, metal slides (Not big drawers Ht 24) and on request, soft-close mechanisms with surcharge (Not on drawers Ht 8 and big drawers Ht 24).
- They cannot be adjusted in height or width.
- The drawers W 90 Ht 16 Dpt 56.3 and Dpt 45 are equipped with bottom panel support.

### IN ALTERNATIVE: Drawers/Big drawers CHARM (with surcharge)

- Fitted with height-adjustable, soft-close "Quadro" type slides.
- Inner drawer/big drawer in CHARM finish.
- They cannot be adjusted in height or width.
- In the modular units, the big drawers W 120, 135, 150 and 180 consist of a single front panel and double drawer lining. The big drawers W 135, 150 and 180 are available only for modular units Dpt 45.
- Drawers W 120 and big drawers W 120, 135, 150 and 180 are always in the CHARM version.

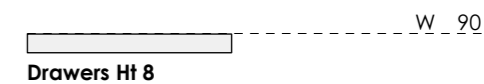
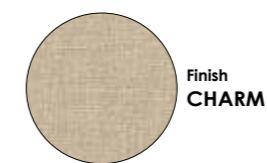

Drawers Ht 8

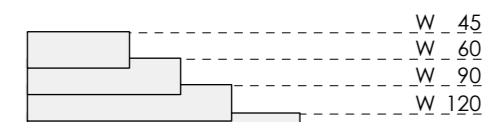

Drawers Ht 16

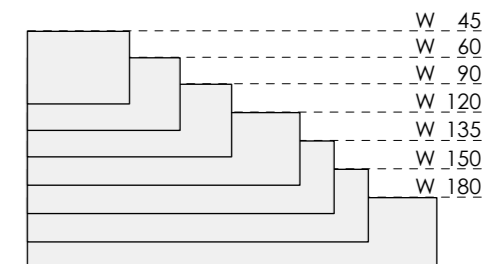

Big drawers Ht 32



Big drawers Ht 24 (for beds and sofas only)

\* Finishing with textured effect  
\* UV glossy finishing  
\* Bianco UV (BU3Q) not available for Ht 288 doors.

# CLUB fronts

Colours available

Rovere white <b>RW3Q</b>	Rovere Dorian <b>RD5T</b>	Ciliegio bianco <b>CB6K</b>	Noce naturale <b>NN7H</b>	Noce <b>NC4B</b>	Eucalipto <b>CL1X</b>	Malta <b>ML7H</b>
Feltro <b>FL8X</b>	Cemento Masdar <b>CM3Q</b>	Bianco opaco <b>BI7A</b>	Desert <b>DS9L</b>	Canapa <b>CN1X</b>	Moka <b>MK6B</b>	Grigio Dorian <b>GL4R</b>
Basalto <b>BS5T</b>	Grigio titanio <b>GZ8T</b>	Domy <b>DM7P</b>	Agave <b>GV7A</b>	Verde Alpi <b>VA5T</b>	Cadaques <b>CQ3Q</b>	Blu indaco <b>BI4B</b>
Blu opale <b>BO7H</b>	Cipria <b>CP4J</b>	Rosa bubble <b>RB7Y</b>	Giallo zafferano <b>GZ8A</b>	Corallo <b>CR5T</b>		

## Dimensions available

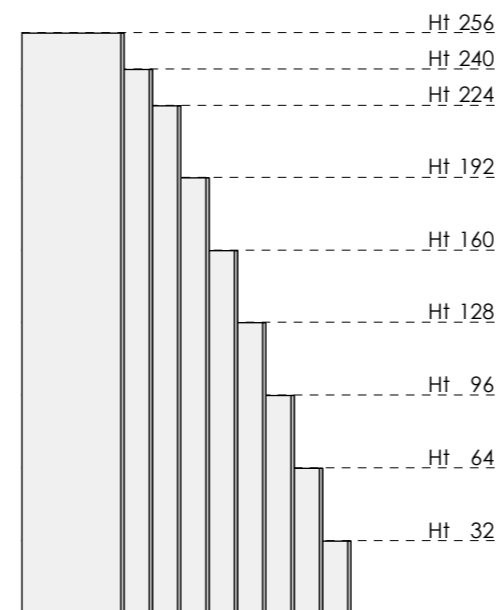

Doors W 30, 45 and 60

- Fitted with decelerated hinges.
- The elements with pairs of doors are provided with only one handle. In elements with doors W 30 + 60 the handle is placed on the W 60 door. Upon customer's request, CLUB handles can be mounted on both doors.
- Bar lock and cylinder not available.

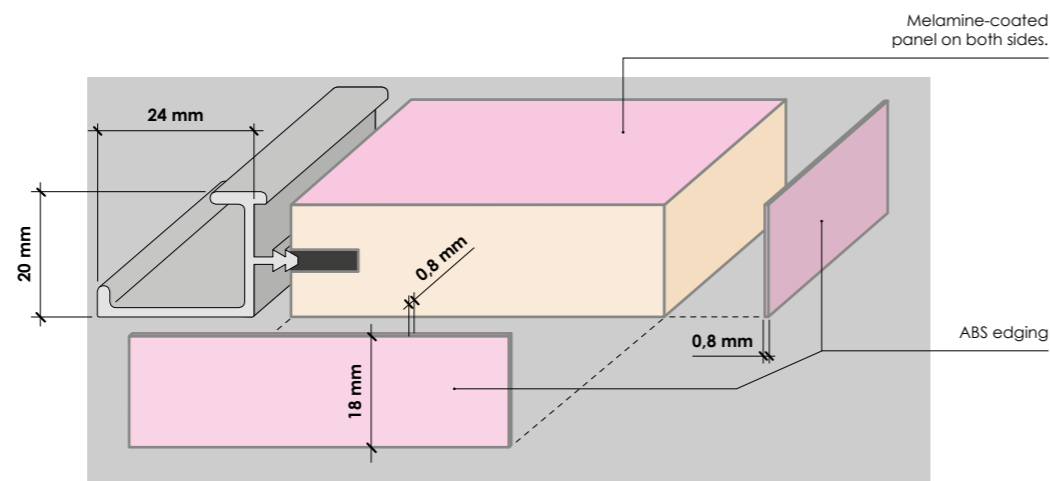

## CLUB handle

Full-length aluminium handle powder coated.

Colours available

<b>BI7A</b>	<b>DM7P</b>	<b>RB7Y</b>
<b>DS9L</b>	<b>GV7A</b>	<b>GZ8A</b>
<b>CN1X</b>	<b>VA5T</b>	<b>CR5T</b>
<b>MK6B</b>	<b>CQ3Q</b>	
<b>GL4R</b>	<b>BI4B</b>	
<b>BS5T</b>	<b>BO7H</b>	
<b>GZ8T</b>	<b>CP4J</b>	

✳ Finishing with textured effect

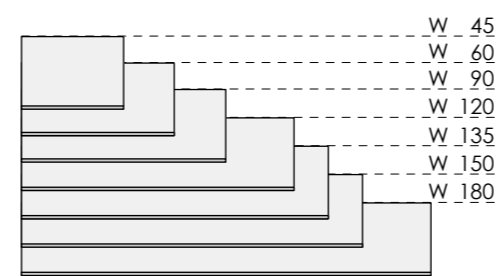

Flap doors Ht 32

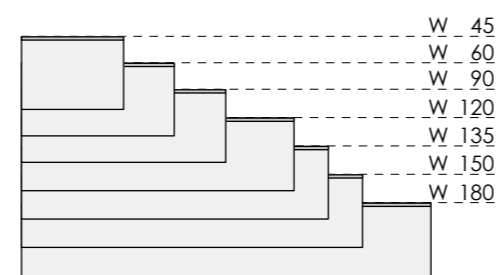

Folding doors Ht 32

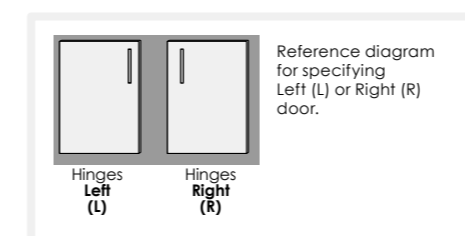

## Drawers/Big drawers CHARM

- Fitted with height-adjustable, soft-close "Quadro" type slides.
- Inner drawer/big drawer in CHARM finish.
- They cannot be adjusted in height or width.
- In the modular units, the big drawers W 120, 135, 150 and 180 consist of a single front panel and double drawer lining. The big drawers W 135, 150 and 180 are available only for modular units Dpt 45.
- In the drawers Ht 8 the P11 knob is always sent.

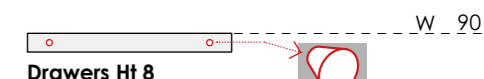
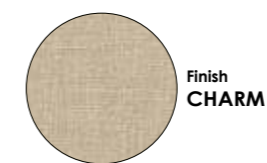

Drawers Ht 8

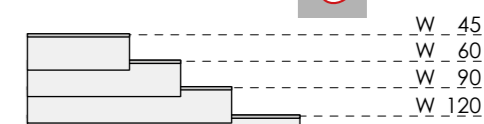

Drawers Ht 16

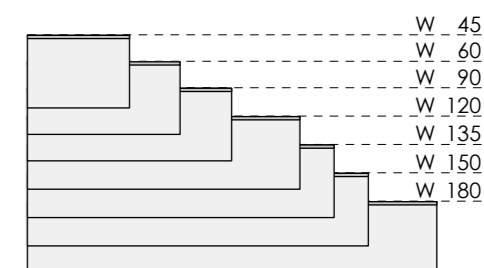

Big drawers Ht 32



Big drawers Ht 24 (for beds and sofas only)

# WINDOW fronts

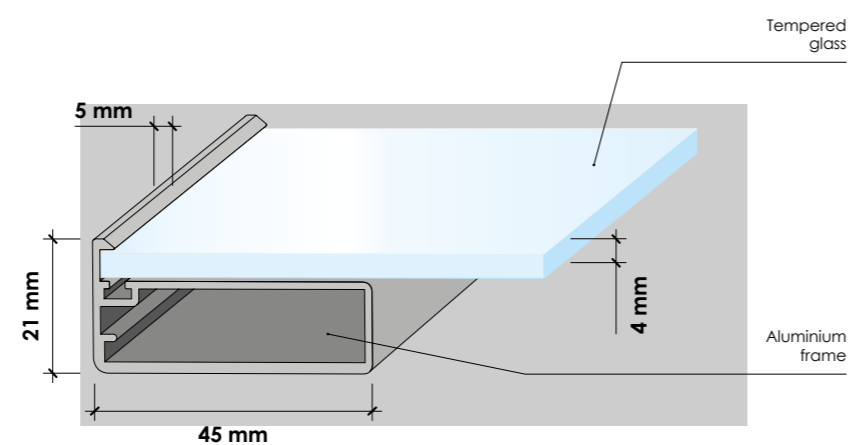
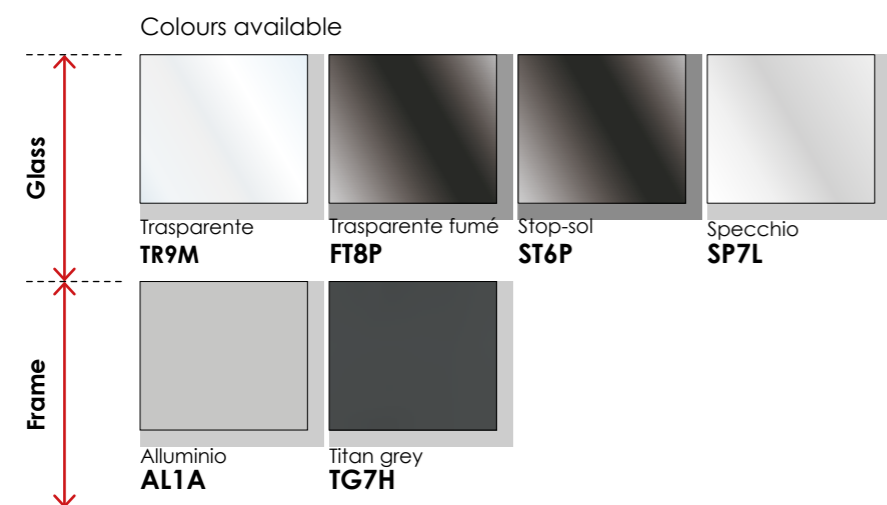

## Dimensions available

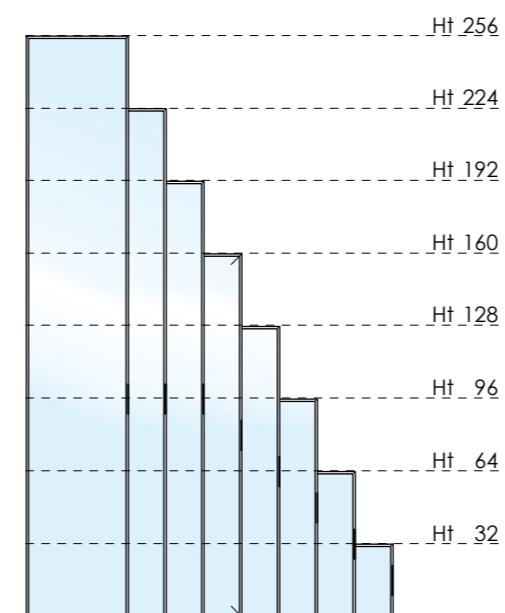

Doors W 45 and 60

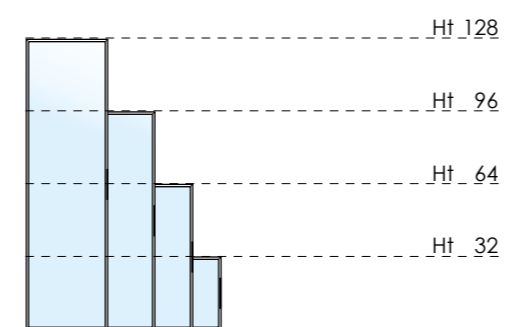

Doors W 30

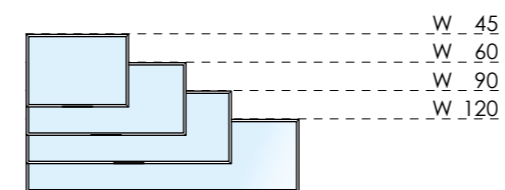

Flap and folding doors Ht 32

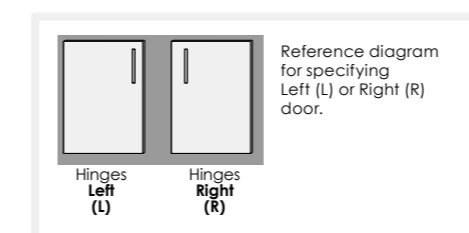

- Tempered glass Th 0.4.
- These are fitted with handles integrated in the frame always placed halfway up the door, except for doors Ht 224 and 256 where the handle is at Ht 102 from the ground.
- The handle of the WINDOW door is not in line with the handle of the laminated door.
- They cannot be fitted with a lock.
- Fitted with decelerated hinges.
- These items' height and width cannot be altered.

We recommend against positioning doors with aluminium frame as shown because the handle might be too high up

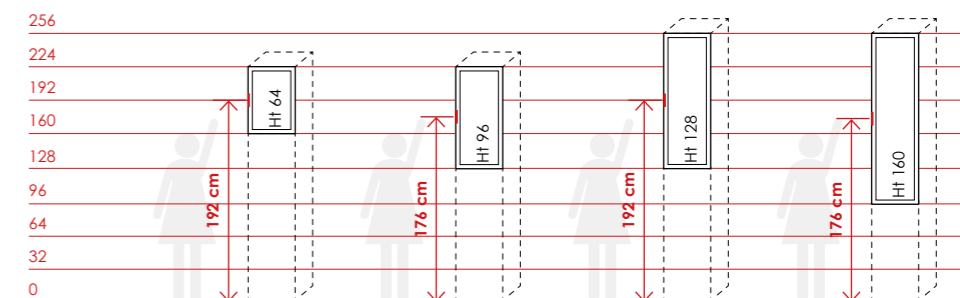

Alluminio (AL1A) and Titan grey (TG7H) colour handle

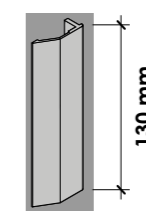

# LINEAR sliding doors

Colours available

<b>Rovere white RW3Q</b>	<b>Rovere Dorian RD5T</b>	<b>Ciliegio bianco CB6K</b>	<b>Noce naturale NN7H</b>	<b>Noce NC4B</b>	<b>Eucalipto CL1X</b>	<b>Malta ML7H</b>
<b>Feltro FL8X</b>	<b>Cemento Masdar CM3Q</b>	<b>Bianco opaco BI7A</b>	<b>Desert DS9L</b>	<b>Canapa CN1X</b>	<b>Moka MK6B</b>	<b>Grigio Dorian GL4R</b>
<b>Basalto BS5T</b>	<b>Grigio titanio GZ8T</b>	<b>Domy DM7P</b>	<b>Agave GV7A</b>	<b>Verde Alpi VA5T</b>	<b>Cadaques CQ3Q</b>	<b>Blu indaco BI4B</b>
<b>Blu opale BO7H</b>	<b>Cipria CP4J</b>	<b>Rosa bubble RB7Y</b>	<b>Giallo zafferano GZ8A</b>	<b>Corallo CR5T</b>		

**Bianco UV BU3Q**  
**Specchio SP7L**

Matte  
Glossy  
Glass

## Dimensions available

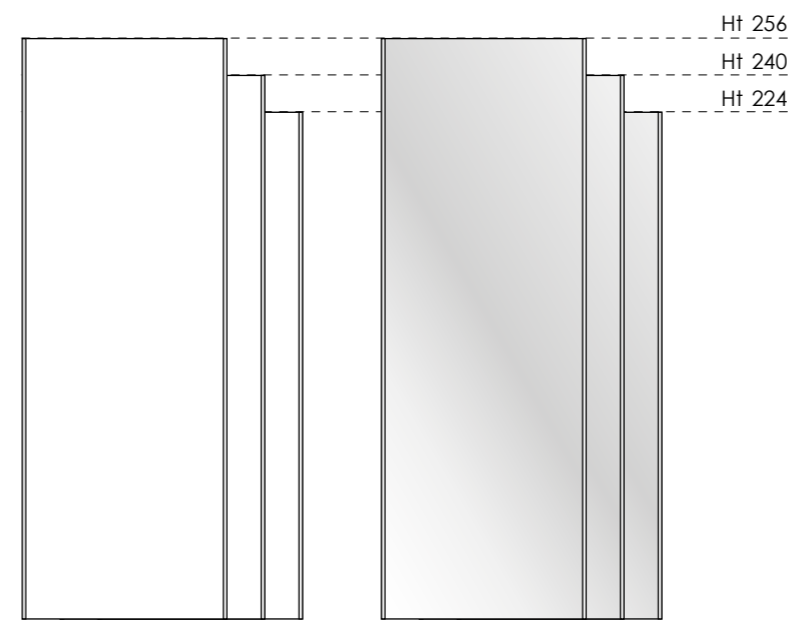

### LINEAR melamine-coated doors/Mirror doors W 91.1

- The mirror Th 0.4 is applied on a white melamine-coated panel Th 1.4.
- These items' height and width cannot be altered.

## Vertical trim

In aluminium, anodised or with decorative coating, with adjustable internal tie-rods.

Colours available

<b>RW3Q</b>	<b>FL8X</b>	<b>BS5T</b>	<b>BO7H</b>
<b>RD5T</b>	<b>CM3Q</b>	<b>GZ8T</b>	<b>CP4J</b>
<b>CB6K</b>	<b>BI7A</b>	<b>DM7P</b>	<b>RB7Y</b>
<b>NN7H</b>	<b>DS9L</b>	<b>GV7A</b>	<b>GZ8A</b>
<b>NC4B</b>	<b>CN1X</b>	<b>VA5T</b>	<b>CR5T</b>
<b>CL1X</b>	<b>MK6B</b>	<b>CQ3Q</b>	
<b>ML7H</b>	<b>GL4R</b>	<b>BI4B</b>	

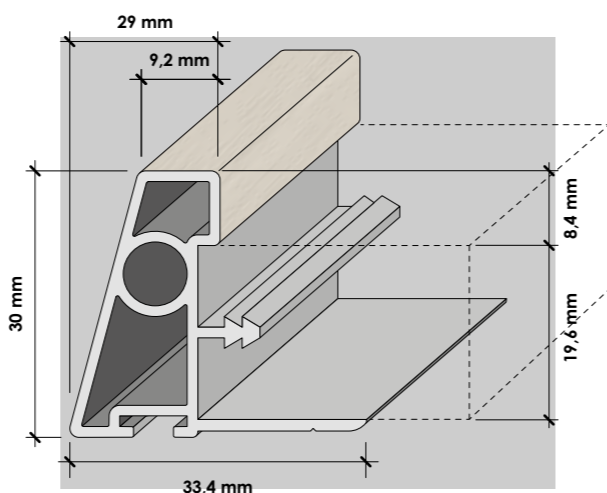

When ordering wardrobes with 2 doors, it is essential to specify whether the projecting door is R or L. The side panel next to the projecting door has depth 58 cm, while the side panel next to the non-projecting door is 54.5 cm deep.

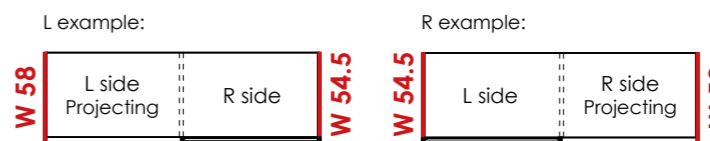

The door opening diagram applies for all wardrobes with sliding doors. **Door opening directions cannot be reversed.**

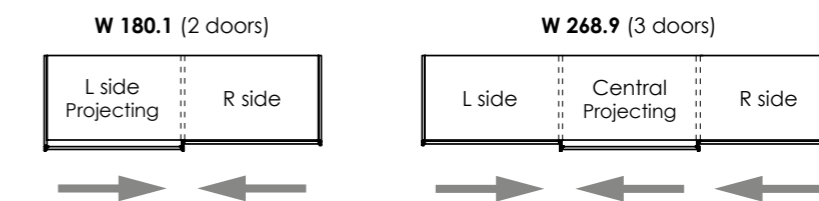

- ✳ Finishing with textured effect
- ★ UV glossy finishing



# SECTOR and DIAGONAL sliding doors

Colours available

<b>Rovere white RW3Q</b>	<b>Rovere Dorian RD5T</b>	<b>Ciliegio bianco CB6K</b>	<b>Noce naturale NN7H</b>	<b>Noce NC4B</b>	<b>Eucalipto CL1X</b>	<b>Malta ML7H</b>
<b>Feltro FL8X</b>	<b>Cemento Masdar CM3Q</b>	<b>Bianco opaco BI7A</b>	<b>Desert DS9L</b>	<b>Canapa CN1X</b>	<b>Moka MK6B</b>	<b>Grigio Dorian GL4R</b>
<b>Basalto BS5T</b>	<b>Grigio titanio GZ8T</b>	<b>Domy DM7P</b>	<b>Agave GV7A</b>	<b>Verde Alpi VA5T</b>	<b>Cadaques CQ3Q</b>	<b>Blu indaco BI4B</b>
<b>Blu opale BO7H</b>	<b>Cipria CP4J</b>	<b>Rosa bubble RB7Y</b>	<b>Giallo zafferano GZ8A</b>	<b>Corallo CR5T</b>		

Matte

Glossy

**Bianco UV BU3Q**

## Dimensions available

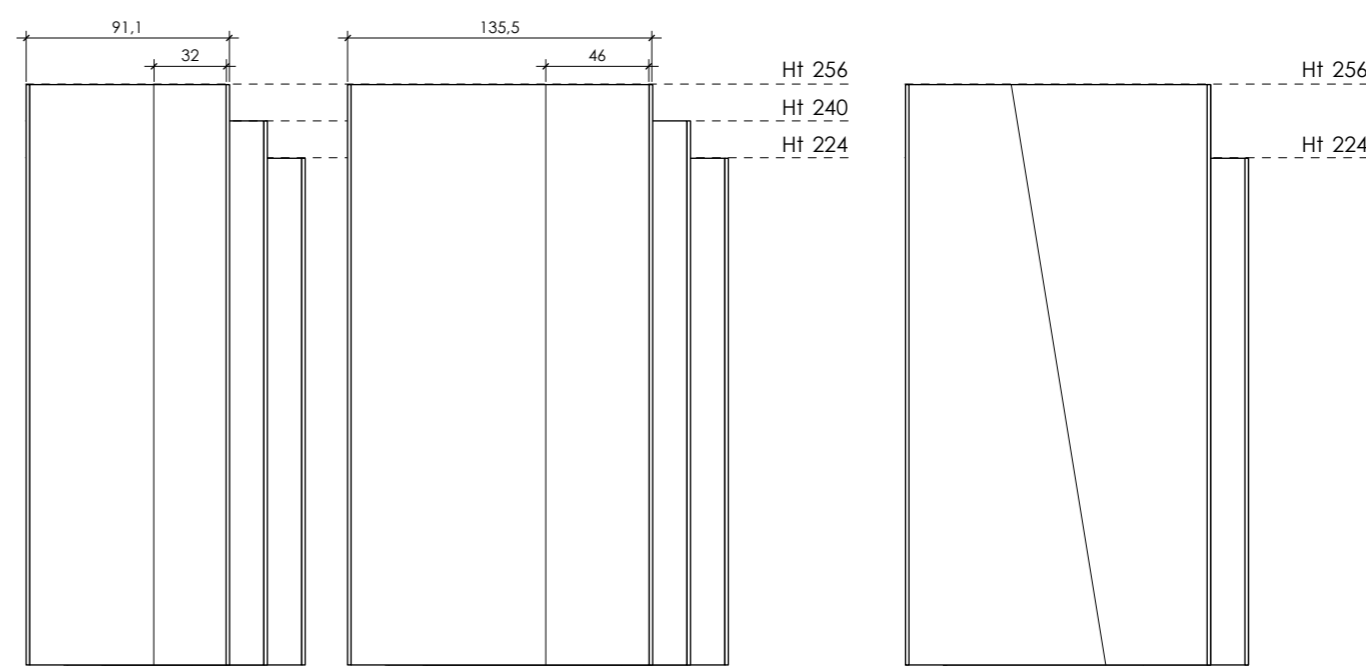

**SECTOR melamine-coated doors W 91.1 and 135.5**

• These items' height and width cannot be altered.

**DIAGONAL melamine-coated doors W 135.5**

• These items' height and width cannot be altered.

## Front customisation

Wardrobe fronts can be customised (see indications in the chapter on DIAGONAL and SECTOR wardrobes with sliding doors).

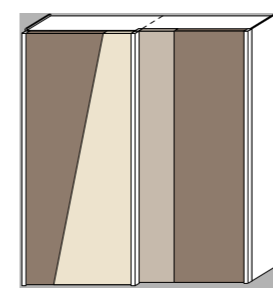

## Vertical trim

In aluminium, anodised or with decorative coating, with adjustable internal tie-rods.

Colours available

<b>RW3Q</b>	<b>FL8X</b>	<b>BS5T</b>	<b>BO7H</b>
<b>RD5T</b>	<b>CM3Q</b>	<b>GZ8T</b>	<b>CP4J</b>
<b>CB6K</b>	<b>BI7A</b>	<b>DM7P</b>	<b>RB7Y</b>
<b>NN7H</b>	<b>DS9L</b>	<b>GV7A</b>	<b>GZ8A</b>
<b>NC4B</b>	<b>CN1X</b>	<b>VA5T</b>	<b>CR5T</b>
<b>CL1X</b>	<b>MK6B</b>	<b>CQ3Q</b>	
<b>ML7H</b>	<b>GL4R</b>	<b>BI4B</b>	

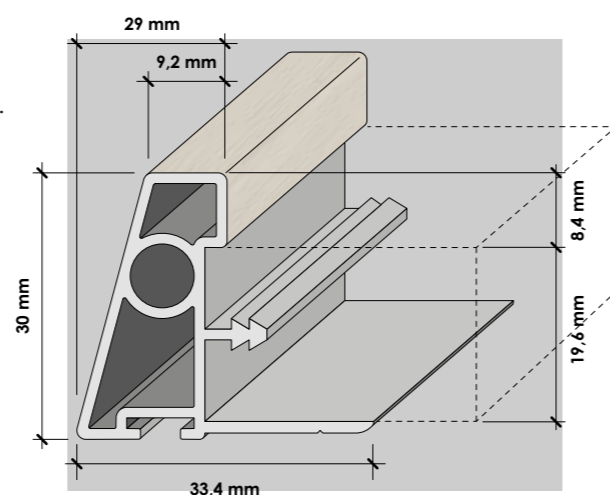

When ordering wardrobes with 2 doors, it is essential to specify whether the projecting door is R or L. The side panel next to the projecting door has depth 58 cm, while the side panel next to the non-projecting door is 54.5 cm deep.

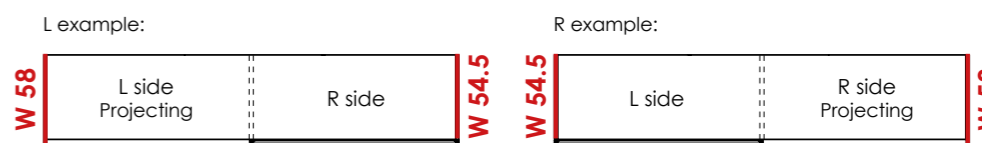

The door opening diagram applies for all wardrobes with sliding doors. **Door opening directions cannot be reversed.**

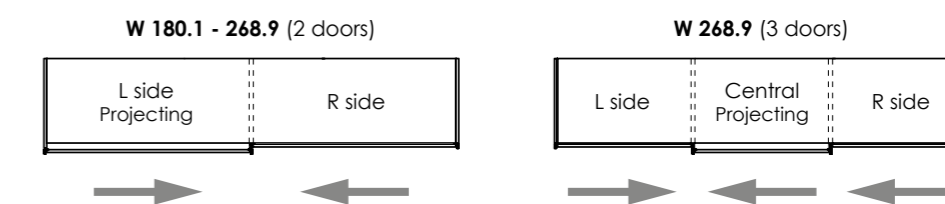

✳ Finishing with textured effect  
 ✳ UV glossy finishing

# RIVIERA sliding doors

Colours available

Rovere white <b>RW3Q</b>	Rovere Dorian <b>RD5T</b>	Ciliegio bianco <b>CB6K</b>	Noce naturale <b>NN7H</b>	Noce <b>NC4B</b>	Eucalipto <b>CL1X</b>	Malta <b>ML7H</b>
Feltro <b>FL8X</b>	Cemento Masdar <b>CM3Q</b>	Bianco opaco <b>BI7A</b>	Desert <b>DS9L</b>	Canapa <b>CN1X</b>	Moka <b>MK6B</b>	Grigio Dorian <b>GL4R</b>
Basalto <b>BS5T</b>	Grigio titanio <b>GZ8T</b>	Domy <b>DM7P</b>	Agave <b>GV7A</b>	Verde Alpi <b>VA5T</b>	Cadaques <b>CQ3Q</b>	Blu indaco <b>BI4B</b>
Blu opale <b>BO7H</b>	Cipria <b>CP4J</b>	Rosa bubble <b>RB7Y</b>	Giallo zafferano <b>GZ8A</b>	Corallo <b>CR5T</b>		

## Dimensions available

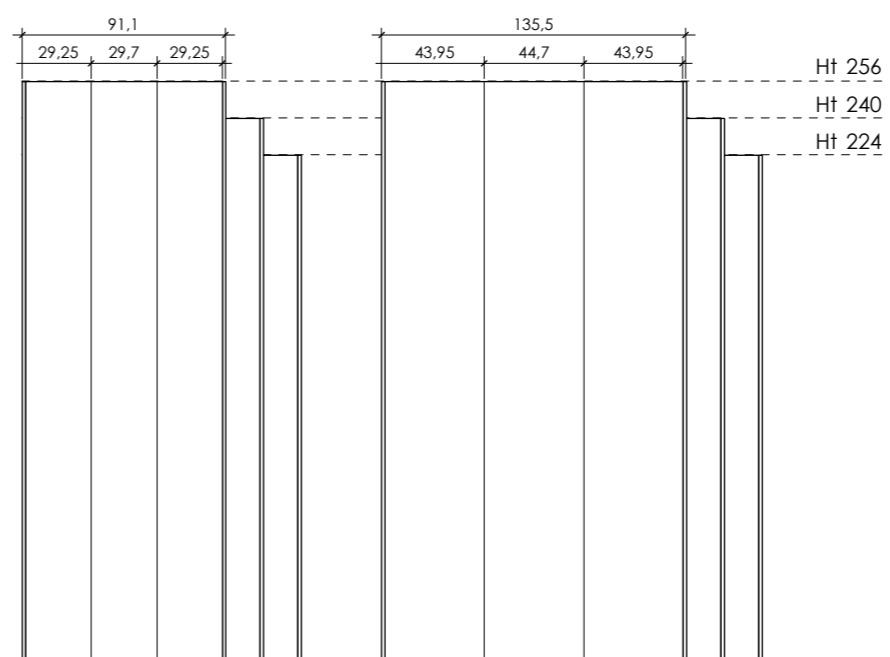

### RIVIERA melamine-coated doors W 91.1 and 135.5

• These items' height and width cannot be altered.

## Front customisation

Wardrobe fronts can be customised (see indications in the chapter on RIVIERA wardrobes with sliding doors).

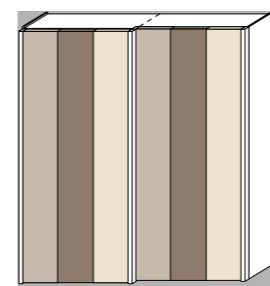

## Vertical trim

In aluminium, anodised or with decorative coating, with adjustable internal tie-rods.

Colours available

<b>RW3Q</b>	<b>FL8X</b>	<b>BS5T</b>	<b>BO7H</b>
<b>RD5T</b>	<b>CM3Q</b>	<b>GZ8T</b>	<b>CP4J</b>
<b>CB6K</b>	<b>BI7A</b>	<b>DM7P</b>	<b>RB7Y</b>
<b>NN7H</b>	<b>DS9L</b>	<b>GV7A</b>	<b>GZ8A</b>
<b>NC4B</b>	<b>CN1X</b>	<b>VA5T</b>	<b>CR5T</b>
<b>CL1X</b>	<b>MK6B</b>	<b>CQ3Q</b>	
<b>ML7H</b>	<b>GL4R</b>	<b>BI4B</b>	

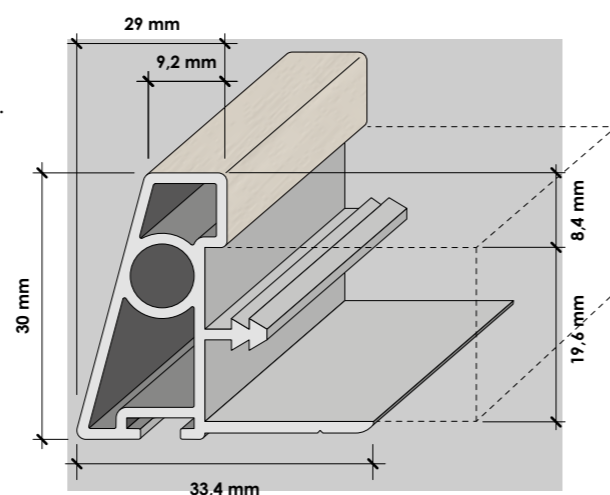

When ordering wardrobes with 2 doors, it is essential to specify whether the projecting door is R or L. The side panel next to the projecting door has depth 58 cm, while the side panel next to the non-projecting door is 54.5 cm deep.

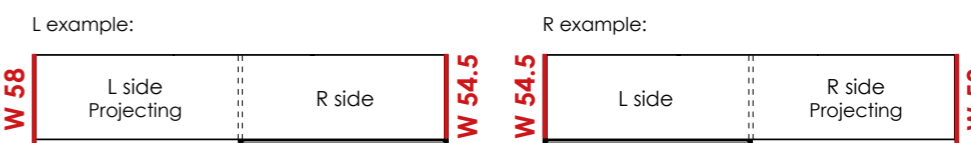

The door opening diagram applies for all wardrobes with sliding doors. **Door opening directions cannot be reversed.**

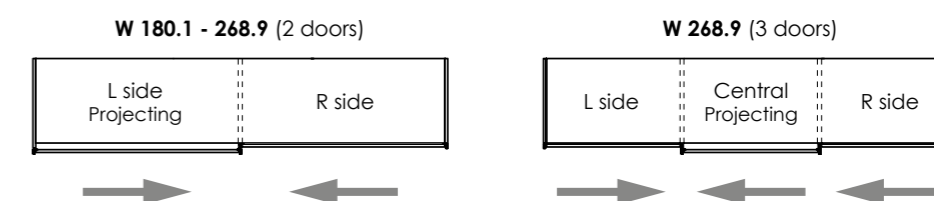

✳ Finishing with textured effect

# INSERTO sliding doors

Colours available

<b>Rovere white RW3Q</b>	<b>Rovere Dorian RD5T</b>	<b>Ciliegio bianco CB6K</b>	<b>Noce naturale NN7H</b>	<b>Noce NC4B</b>	<b>Eucalipto CL1X</b>	<b>Malta ML7H</b>
<b>Feltro FL8X</b>	<b>Cemento Masdar CM3Q</b>	<b>Bianco opaco BI7A</b>	<b>Desert DS9L</b>	<b>Canapa CN1X</b>	<b>Moka MK6B</b>	<b>Grigio Dorian GL4R</b>
<b>Basalto BS5T</b>	<b>Grigio titanio GZ8T</b>	<b>Domy DM7P</b>	<b>Agave GV7A</b>	<b>Verde Alpi VA5T</b>	<b>Cadaques CQ3Q</b>	<b>Blu indaco BI4B</b>
<b>Blu opale BO7H</b>	<b>Cipria CP4J</b>	<b>Rosa bubble RB7Y</b>	<b>Giallo zafferano GZ8A</b>	<b>Corallo CR5T</b>		

Matte

Glossy

**Bianco UV BU3Q**

## Dimensions available

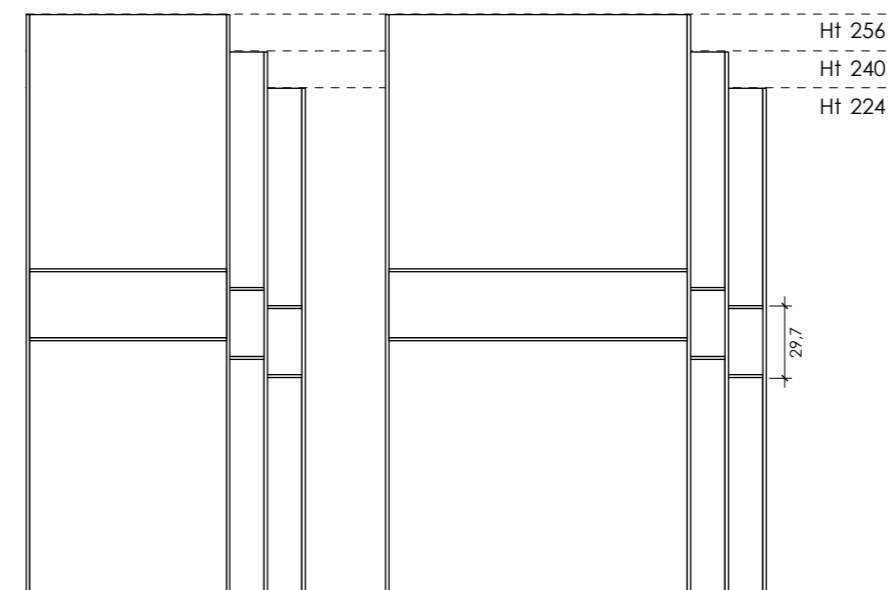

### INSERTO melamine-coated doors W 91.1 and 135.5

• These items' height and width cannot be altered.

## Front customisation

Wardrobe fronts can be customised (see indications in the chapter on INSERTO wardrobes with sliding doors).

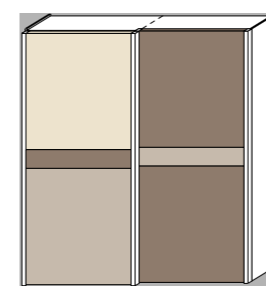

## Vertical trim

In aluminium, anodised or with decorative coating, with adjustable internal tie-rods.

Colours available

<b>RW3Q</b>	<b>FL8X</b>	<b>BS5T</b>	<b>BO7H</b>
<b>RD5T</b>	<b>CM3Q</b>	<b>GZ8T</b>	<b>CP4J</b>
<b>CB6K</b>	<b>BI7A</b>	<b>DM7P</b>	<b>RB7Y</b>
<b>NN7H</b>	<b>DS9L</b>	<b>GV7A</b>	<b>GZ8A</b>
<b>NC4B</b>	<b>CN1X</b>	<b>VA5T</b>	<b>CR5T</b>
<b>CL1X</b>	<b>MK6B</b>	<b>CQ3Q</b>	
<b>ML7H</b>	<b>GL4R</b>	<b>BI4B</b>	

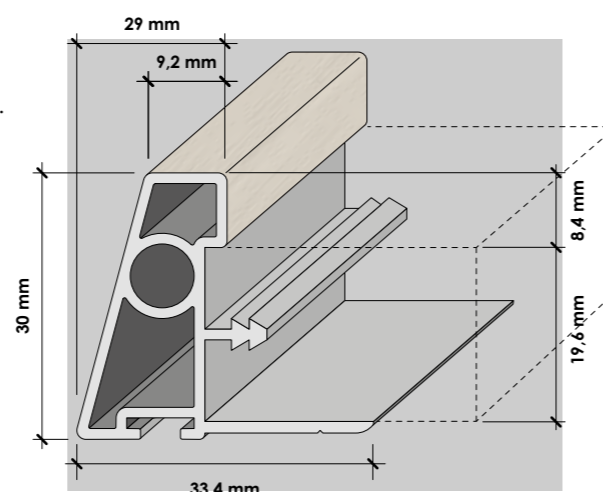

When ordering wardrobes with 2 doors, it is essential to specify whether the projecting door is R or L. The side panel next to the projecting door has depth 58 cm, while the side panel next to the non-projecting door is 54.5 cm deep.

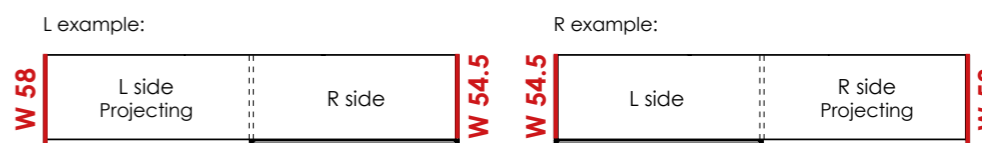

The door opening diagram applies for all wardrobes with sliding doors. **Door opening directions cannot be reversed.**

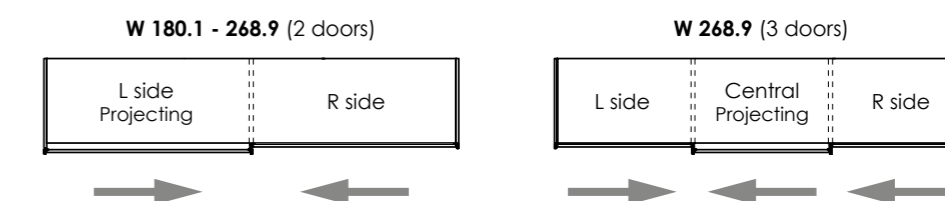

- ✳ Finishing with textured effect
- ✳ UV glossy finishing
- ✳ Bianco UV (BU3Q) not available for W 135.5 doors.

# Custom cuts

**35,00** cost of cutting each component of the element.

Cuts are carried out only on request with explanatory drawing.

It is not possible to create two-sided elements.

For customised cuts of units that are not specified, consult the technical notes inserted in the various sections.

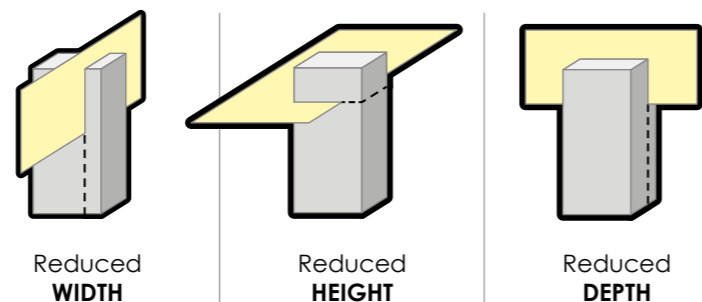

	Reduced WIDTH	Reduced HEIGHT	Reduced DEPTH
Melamine-faced standard doors	●	●	-
Vasistas and folding doors	●	●	-
Drawers and big drawers	●	●	●
Fronts CLUB	●	● * <sub>1</sub>	-
Fronts WINDOW	●	●	-
Doors with oblique cut	●	●	-
Sliding doors	●	●	-
Bellows doors	●	●	●
Metal parts and glass elements	●	●	●
Tables, chairs and mirrors	●	●	●
Wardrobes	●	●	●
Wardrobes with TV stand element	●	●	●
Wardrobes with pull-out desk	●	●	●
Wardrobe for passage	●	●	●
External corner wardrobes	●	●	●
TWIG wardrobes	●	●	●
Service furniture	●	●	●
Storage units	●	●	●
Wardrobe full corners and wood corner blocks	●	●	●
Wardrobe corners	●	●	●
Wardrobe/storage unit end elements	●	●	●
End bookshelves LOGIK, VELA, SMART and QUID	●	●	●
Walk-in wardrobes SMALL, BIG and LARGE	●	●	●
Wardrobes with sliding doors	●	●	●
Wardrobes with shaped side-panels	●	●	●
RIALTO bridge unit with bellow doors	●	●	●
RIALTO overhead/corner overhead structures	●	●	●
Side panels and SMART bookcase bridge support	●	●	●
Beds and ottomans	● * <sub>2</sub>	●	● * <sub>3</sub>
BAIA sofa beds	●	●	●
Sofas, padded beds, save space CLICK, MUVI and MULTIFUNCTION beds	●	●	●
FLOTTA container	●	●	●
Loft beds	●	●	●
Bunk beds, HAPPY	●	●	●
Ladders with shaped side elements and guards	●	●	●
Shaped tops and shelves	●	●	●
PODIO (desk, shelf and bench) and bench	●	●	●
Shelves	●	●	●
Cube units, PEPITA and DARSENA boiserie systems	●	●	●
Sideboards	●	●	●
Modular units, suspended modular units and wall units	●	●	●
Top panels for modular units	●	●	● * <sub>4</sub>

- Processing executable
- Processing not executable

- \*<sub>1</sub> Only wardrobes between Ht 225.6 and 257.6 can be reduced.
- \*<sub>2</sub> SUMO and ELFO beds not included.
- \*<sub>3</sub> Beds with accessories not included.
- \*<sub>4</sub> Top Th 5.5 excluded.

## Reduced Width

**Example:** To reduce the width of a two-door wardrobe, 6 components have to be cut (bottom panel, top, shelf, back panel and 2 doors); therefore, the cost of this process is:  
35,00 x 6 = 210,00.

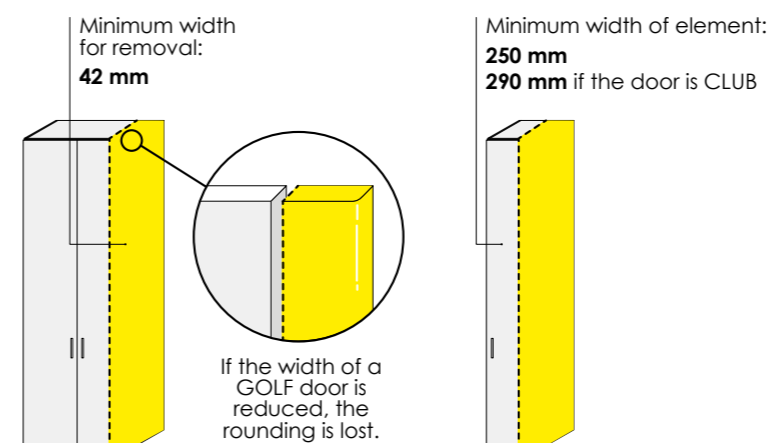

## Reduced Height

**Example:** To reduce the height of a two-door wardrobe, 5 components have to be cut (2 doors, back panel and 2 side panels); therefore the cost of this operation is:  
35,00 x 5 = 175,00

**Cuts are always made at the top**



## Reduced Depth

With small depth wardrobes we recommend using sliding clothes rails.

**Example:** To reduce the depth of a wardrobe, 5 components have to be cut (2 side panels, bottom panel, top panel and shelf); therefore the cost for processing amounts to:  
35,00 x 5 = 175,00

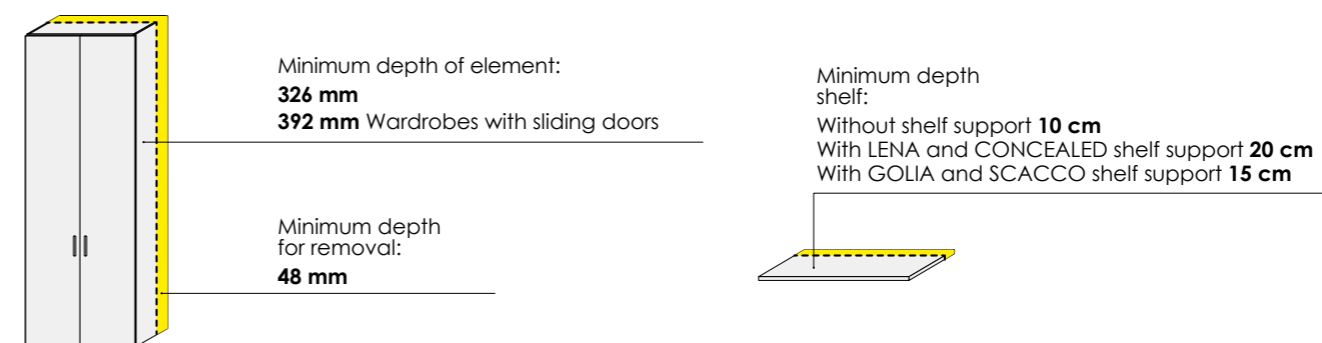



# Filler strips

**Vertical**  
(vertical vein)  
for hinged door and sliding door

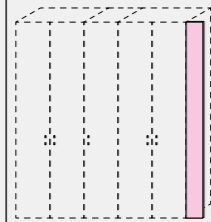

**Horizontal**  
(horizontal vein)  
for hinged door

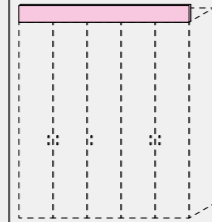

Code	PK00.44E	PK00.45M	
matte			
glossy			
	<p>Side panel Wall Door</p> <p>Minimum height: <b>320 mm</b> Maximum height: <b>3.000 mm</b> Minimum width: <b>40 mm</b> Maximum width: <b>250 mm</b></p> <p>* Limit for strips in glossy finish</p>	<p>Ceiling Door</p> <p>Minimum height: <b>40 mm</b> Maximum height: <b>250 mm</b> Minimum width: <b>320 mm</b> Maximum width: <b>3.000 mm</b> * <b>2.556 mm</b></p>	

Components in **Types and colors FRONT**

<b>GROUP 1 colors</b>	Rovere Dorian <b>RD5T</b>	Rovere white <b>RW3Q</b>	Noce naturale <b>NN7H</b>	Eucalipto <b>CL1X</b>	Domy <b>DM7P</b>	Bianco UV <b>BU3Q</b>
	Ciliegio bianco <b>CB6K</b>	Malta <b>ML7H</b>	Feltro <b>FL8X</b>	Cemento Masdar <b>CM3Q</b>	Blu indaco <b>BI4B</b>	
	Noce <b>NC4B</b>	Desert <b>DS9L</b>	Canapa <b>CN1X</b>	Moka <b>MK6B</b>	Cipria <b>CP4J</b>	
	Bianco opaco <b>BI7A</b>	Grigio Dorian <b>GL4R</b>	Basalto <b>BS5T</b>	Grigio titanio <b>GZ8T</b>	Rosa bubble <b>RB7Y</b>	
	Agave <b>GV7A</b>	Verde Alpi <b>VA5T</b>	Cadaques <b>CQ3Q</b>	Giallo zafferano <b>GZ8A</b>		
	Blu opale <b>BO7H</b>			Corallo <b>CR5T</b>		

**Types and colors FRONT**

**ONE**  
matte  
glossy

Rovere white <b>RW3Q</b>	Rovere Dorian <b>RD5T</b>	Ciliegio bianco <b>CB6K</b>	Noce naturale <b>NN7H</b>	Noce <b>NC4B</b>	Eucalipto <b>CL1X</b>	Malta <b>ML7H</b>
Feltro <b>FL8X</b>	Cemento Masdar <b>CM3Q</b>	Bianco opaco <b>BI7A</b>	Desert <b>DS9L</b>	Canapa <b>CN1X</b>	Moka <b>MK6B</b>	Grigio Dorian <b>GL4R</b>
Basalto <b>BS5T</b>	Grigio titanio <b>GZ8T</b>	Domy <b>DM7P</b>	Agave <b>GV7A</b>	Verde Alpi <b>VA5T</b>	Cadaques <b>CQ3Q</b>	Blu indaco <b>BI4B</b>
Blu opale <b>BO7H</b>	Cipria <b>CP4J</b>	Rosa bubble <b>RB7Y</b>	Giallo zafferano <b>GZ8A</b>	Corallo <b>CR5T</b>		

Bianco UV  
**BU3Q**

**CLUB**

Specify the color of the CLUB handle

Bianco opaco <b>BI7A</b>	Desert <b>DS9L</b>	Canapa <b>CN1X</b>	Moka <b>MK6B</b>	Grigio Dorian <b>GL4R</b>	Basalto <b>BS5T</b>	Grigio titanio <b>GZ8T</b>
Domy <b>DM7P</b>	Agave <b>GV7A</b>	Verde Alpi <b>VA5T</b>	Cadaques <b>CQ3Q</b>	Blu indaco <b>BI4B</b>	Blu opale <b>BO7H</b>	Cipria <b>CP4J</b>
Rosa bubble <b>RB7Y</b>	Giallo zafferano <b>GZ8A</b>	Corallo <b>CR5T</b>				

**WINDOW**

Trasparente  
**TR9M**

Trasparente fumé  
**FT8P**

Stop-sol  
**ST6P**

Specchio  
**SP7L**

Specify the color of the aluminum frame

Alluminio <b>AL1A</b>	Titan grey <b>TG7H</b>
--------------------------	---------------------------

**Accessories, Single doors, Chairs and Tables**

Knobs and handles	48
Knob and handle positions	56
Colour sample sets and paints for repairs	60
Panels and edges	61
Hardware	62
Miscellaneous	64
Lighting	65
Tables and coffee tables	66
Chairs and armchairs for study area	68
Doors	70
Doors for over-bar wardrobe of RIALTO bridge unit	76
Door panel without holes for hinges and handles	77
Drawers and big drawers	78

# Knobs and handles



## BALL

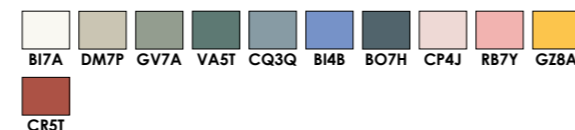

W mm	Span mm	Code	Code
27	-	G83W	PK00.28V

Ht mm 27 | Projection mm 29

## PIN



W mm	Span mm	Code	Code
13	-	G76W	PK00.00G

Ht mm 13 | Projection mm 25

## P11



W mm	Span mm	Code	Code
21	-	G01M	P51.18B

Ht mm 21 | Projection mm 20

## P99



W mm	Span mm	Code	Code
15	-	G04W	P52.61P

Beige leather thong.

Ht mm 15 | Projection mm 35

- VERTICAL handles
- HORIZONTAL handles

## BUL



W mm	Span mm	Code	Code	Code
52	32	-	G77Z	PK00.01P
180	160	G79F	G78C	PK00.02V

Ht mm 9 | Projection mm 22,5

## DASH



**Solid natural ash wood**  
Wood is a natural product and as such is subject to variations in color and grain. Differences in grain or color therefore do not constitute grounds for dispute.

W mm	Span mm	Code	Code	Code
95	32	-	G80K	PK00.03B
223	160	-	G81Q	PK00.04H

Ht mm 44 | Projection mm 20

## DOT

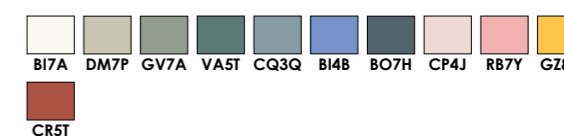

W mm	Span mm	Code	Code	Code
101	32	-	G31T	P99.62A

Ht mm 51 | Projection mm 23

## FRAME

Available only for the following groups  
TULIP - QUADRO



W mm	Span mm	Code	Code	Code
114	32	G60M	-	P99.83Q
234	192	G55R	-	P99.86F

Ht mm 80 | Projection mm 25

- |                             |                                  |                              |                                  |                           |
|-----------------------------|----------------------------------|------------------------------|----------------------------------|---------------------------|
| <b>AL1A</b> Alluminio       | <b>CH7Y</b> Champagne spazzolato | <b>DM7P</b> Domy             | <b>LM7A</b> Alluminio spazzolato | <b>RB7Y</b> Rosa bubble   |
| <b>AP4B</b> Acciaio opaco   | <b>CL1X</b> Eucalipto            | <b>DS9L</b> Desert           | <b>MK6B</b> Moka                 | <b>RD5T</b> Rovere Dorian |
| <b>BI4B</b> Blu indaco      | <b>CM3Q</b> Cemento Masdar       | <b>FL8X</b> Feltro           | <b>ML7H</b> Malta                | <b>RW3Q</b> Rovere white  |
| <b>BI7A</b> Bianco opaco    | <b>CN1X</b> Canapa               | <b>GL4R</b> Grigio Dorian    | <b>NC4B</b> Noce                 | <b>VA5T</b> Verde Alpi    |
| <b>BO7H</b> Blu opale       | <b>CP4J</b> Cipria               | <b>GV7A</b> Agave            | <b>NN7H</b> Noce naturale        |                           |
| <b>BS5T</b> Basalto         | <b>CQ3Q</b> Cadaques             | <b>GZ8A</b> Giallo zafferano | <b>NP7H</b> Nero opaco           |                           |
| <b>CB6K</b> Ciliegio bianco | <b>CR5T</b> Corallo              | <b>GZ8T</b> Grigio titanio   | <b>NR4B</b> Nero spazzolato      |                           |

# Knobs and handles



## MEKA

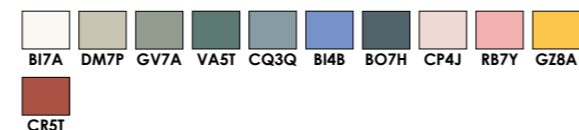

W mm	Span mm	Code	VERTICAL handles	Code	HORIZONTAL handles	Code
41	32	-	<input checked="" type="checkbox"/>	G85C	<input type="checkbox"/>	PK00.29B

Ht mm 8 | Projection mm 25

## META

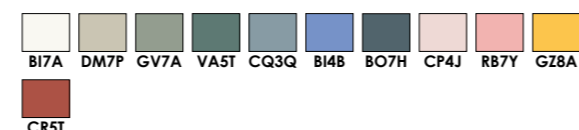

W mm	Span mm	Code	Cannot be fitted on drawers Ht 8	Code	HORIZONTAL handles	Code
98	32	G86F	<input checked="" type="checkbox"/>	-	<input type="checkbox"/>	PK00.30Y

Ht mm 48 | Projection mm 27

## MUN

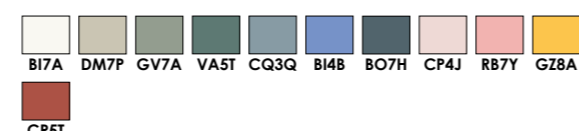

W mm	Span mm	Code	Cannot be fitted on doors with cylinder lock	Code	HORIZONTAL handles	Code
75	32	G75T	<input checked="" type="checkbox"/>	-	<input type="checkbox"/>	P08.03G

Ht mm 75 | Projection mm 28

## NIK



W mm	Span mm	Code	VERTICAL handles	Code	HORIZONTAL handles	Code
52	32	-	<input type="checkbox"/>	G61F	<input type="checkbox"/>	P99.89X
116	96	G62R	<input type="checkbox"/>	-	<input type="checkbox"/>	P99.90C
180	160	G63W	<input type="checkbox"/>	G64Y	<input type="checkbox"/>	P99.91H
276	256	G65L	<input type="checkbox"/>	-	<input type="checkbox"/>	P99.92P
340	320	G66K	<input type="checkbox"/>	-	<input type="checkbox"/>	P99.93U
980	960	G67V	<input type="checkbox"/>	-	<input type="checkbox"/>	P99.94Z

Ht mm 25 | Projection mm 18,5

## POM



**Solid natural ash wood**  
Wood is a natural product and as such is subject to variations in color and grain. Differences in grain or color therefore do not constitute grounds for dispute.

W mm	Span mm	Code	Cannot be fitted on doors with cylinder lock	Code	HORIZONTAL handles	Code
70	32	G82T	<input checked="" type="checkbox"/>	-	<input type="checkbox"/>	PK00.05Q

Ht mm 70 | Projection mm 39

## TWIST

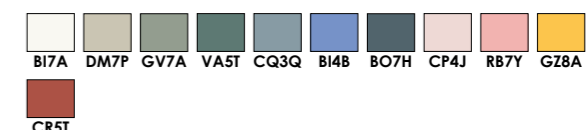

W mm	Span mm	Code	Cannot be fitted on doors with cylinder lock	Code	HORIZONTAL handles	Code
97	32	G49A	<input checked="" type="checkbox"/>	-	<input type="checkbox"/>	P99.75W

Ht mm 103 | Projection mm 25

## GIN



W mm	Span mm	Code	VERTICAL handles	Code	HORIZONTAL handles	Code
143	96	G15B	<input type="checkbox"/>	-	<input type="checkbox"/>	P52.97K
367	320	G22U	<input type="checkbox"/>	-	<input type="checkbox"/>	P52.55F

Ht mm 12 | Projection mm 32

## LOV



W mm	Span mm	Code	VERTICAL handles	Code	HORIZONTAL handles	Code
120	96	G14Y	<input type="checkbox"/>	-	<input type="checkbox"/>	P52.54A

Ht mm 20 | Projection mm 28

VERTICAL handles  
 HORIZONTAL handles

Cannot be fitted on doors with cylinder lock.  
 Cannot be fitted on drawers Ht 8. Knobs BALL are supplied instead.

- |                      |                           |                       |                           |                    |
|----------------------|---------------------------|-----------------------|---------------------------|--------------------|
| AL1A Alluminio       | CH7Y Champagne spazzolato | DM7P Domy             | LM7A Alluminio spazzolato | RB7Y Rosa bubble   |
| AP4B Acciaio opaco   | CL1X Eucalipto            | DS9L Desert           | MK6B Moka                 | RD5T Rovere Dorian |
| BI4B Blu indaco      | CM3Q Cemento Masdar       | FL8X Feltro           | ML7H Malta                | RW3Q Rovere white  |
| BI7A Bianco opaco    | CN1X Canapa               | GL4R Grigio Dorian    | NC4B Noce                 | VA5T Verde Alpi    |
| BO7H Blu opale       | CP4J Cipria               | GV7A Agave            | NN7H Noce naturale        |                    |
| BS5T Basalto         | CQ3Q Cadaques             | GZ8A Giallo zafferano | NP7H Nero opaco           |                    |
| CB6K Ciliegio bianco | CR5T Corallo              | GZ8T Grigio titanio   | NR4B Nero spazzolato      |                    |



# Knobs and handles



## ROD

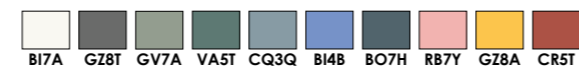

W mm	Span mm	Code	VERTICAL handles	Code	HORIZONTAL handles	Code
107	96	G68E	-			P99.95E
171	160	G58N	G59L			P99.84V

Ht mm 11 | Projection mm 32

## TOY

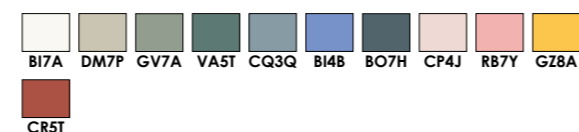
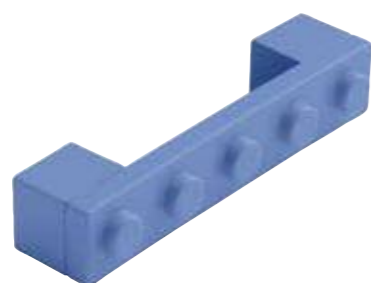

W mm	Span mm	Code	VERTICAL handles	Code	HORIZONTAL handles	Code
128	96	G40S	-			P99.69P

Ht mm 25 | Projection mm 32

## BIS



W mm	Span mm	Code	VERTICAL handles	Code	HORIZONTAL handles	Code
192	160	G50F	G35F			P99.66X

Ht mm 9 | Projection mm 20

## GIG



W mm	Span mm	Code	VERTICAL handles	Code	HORIZONTAL handles	Code
171	160	G19Q	G51B			P65.28W
331	320	G23X	-			P65.31N

Ht mm 20 | Projection mm 30

VERTICAL handles  
HORIZONTAL handles

## MIRA

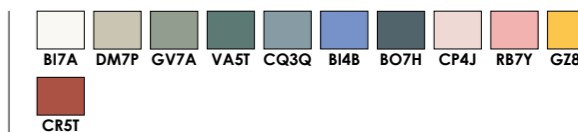

W mm	Span mm	Code	VERTICAL handles	Code	HORIZONTAL handles	Code
170	160	G87K	G88N			PK00.31E

Ht mm 10 | Projection mm 35

## PUL



W mm	Span mm	Code	VERTICAL handles	Code	HORIZONTAL handles	Code
192	160	G28P	G53Z			P93.27R
288	256	G45H	-			P99.72E
992	960	G29S	-			P93.28W

Ht mm 18 | Projection mm 19

## SET



W mm	Span mm	Code	VERTICAL handles	Code	HORIZONTAL handles	Code
175	160	G21R	G52R			P65.30G
335	320	G25D	-			P65.33Y
975	960	G26G	-			P65.34D

Ht mm 29 | Projection mm 20

## VIM



W mm	Span mm	Code	VERTICAL handles	Code	HORIZONTAL handles	Code
180	160	G70T	G71B			P99.97R
276	256	G72P	-			P99.98W
980	960	G73A	-			P99.99B

Ht mm 24 | Projection mm 30

<b>AL1A</b> Alluminio	<b>CH7Y</b> Champagne spazzolato	<b>DM7P</b> Domy	<b>LM7A</b> Alluminio spazzolato	<b>RB7Y</b> Rosa bubble
<b>AP4B</b> Acciaio opaco	<b>CL1X</b> Eucalipto	<b>DS9L</b> Desert	<b>MK6B</b> Moka	<b>RD5T</b> Rovere Dorian
<b>BI4B</b> Blu indaco	<b>CM3Q</b> Cemento Masdar	<b>FL8X</b> Feltro	<b>ML7H</b> Malta	<b>RW3Q</b> Rovere white
<b>BI7A</b> Bianco opaco	<b>CN1X</b> Canapa	<b>GL4R</b> Grigio Dorian	<b>NC4B</b> Noce	<b>VA5T</b> Verde Alpi
<b>BO7H</b> Blu opale	<b>CP4J</b> Cipria	<b>GV7A</b> Agave	<b>NN7H</b> Noce naturale	
<b>BS5T</b> Basalto	<b>CQ3Q</b> Cadaques	<b>GZ8A</b> Giallo zafferano	<b>NR7H</b> Nero opaco	
<b>CB6K</b> Ciliegio bianco	<b>CR5T</b> Corallo	<b>GZ8T</b> Grigio titanio	<b>NR4B</b> Nero spazzolato	

# Knobs and handles

## EASY



W mm	Span mm	Code	Code	Code
348	320	G56F	-	P99.85A

Ht mm 10 | Projection mm 24

## INES

Applicable only on the INSIDE sideboard doors

Recessed handle, supplied mounted on the door and generates specific processing (recess 18 mm). If there are two doors, only one handle is included per element, positioned on the right-hand door.

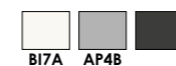

W mm	Span mm	Code	Code	Loose
44	-	G89R	-	-

Ht mm 172 | Projection mm 1,5

VERTICAL handles  
 HORIZONTAL handles

**Solid natural ash wood**  
Wood is a natural product and as such is subject to variations in color and grain. Differences in grain or color therefore do not constitute grounds for dispute.

Span	Knobs and handles	Colors																															
		AL1A	LM7A	CH7Y	NR4B	RW3Q	RD5T	CB6K	NN7H	NC4B	CL1X	ML7H	FL8X	CM3Q	BI7A	DS9L	CN1X	MK6B	GL4R	BS5T	GZ8T	DM7P	GV7A	VA5T	CQ3Q	BI4B	BO7H	CP4J	RB7Y	GZ8A	CR5T		
-	BALL	G83W																															
	PIN	G76W																															
	P11	G01M																															
	P99	G04W																															
32	BUL	G77Z																															
	DASH	G80K																															
	DOT	G31T																															
	FRAME	G60M																															
	MEKA	G85C																															
	META	G86F																															
	MUN	G75T																															
	NIK	G61F																															
	POM	G82T																															
	TWIST	G49A																															
96	GIN	G15B																															
	LOV	G14Y																															
	NIK	G62R																															
	ROD	G68E																															
	TOY	G40S																															
160	BIS	G50F / G35F																															
	BUL	G79F / G78C																															
	DASH	G81Q																															
	GIG	G19Q / G51B																															
	MIRA	G87K / G88N																															
	NIK	G63W / G64Y																															
	PUL	G28P / G53Z																															
	ROD	G58N / G59L																															
	SET	G21R / G52R																															
	VIM	G70T / G71B																															
192	FRAME	G55R																															
	NIK	G65L																															
	PUL	G45H																															
256	VIM	G72P																															
	EASY	G56F																															
	GIG	G23X																															
	GIN	G22U																															
320	NIK	G66K																															
	SET	G25D																															
	NIK	G67V																															
	PUL	G29S																															
960	SET	G26G																															
	VIM	G73A																															

AL1A Alluminio	CH7Y Champagne spazzolato	DM7P Domy	LM7A Alluminio spazzolato	RB7Y Rosa bubble
AP4B Acciaio opaco	CL1X Eucalipto	DS9L Desert	MK6B Moka	RW5T Rovere Dorian
BI4B Blu indaco	CM3Q Cemento Masdar	FL8X Feltro	ML7H Malta	RW3Q Rovere white
BI7A Bianco opaco	CN1X Canapa	GL4R Grigio Dorian	NC4B Noce	VA5T Verde Alpi
BO7H Blu opale	CP4J Cipria	GV7A Agave	NN7H Noce naturale	
BS5T Basalto	CQ3Q Cadaques	GZ8A Giallo zafferano	NP7H Nero opaco	
CB6K Ciliegio bianco	CR5T Corallo	GZ8T Grigio titanio	NR4B Nero spazzolato	

# Knob and handle positions

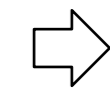

**Knob diagram**

G83W G76W G01M G04W

Doors W 30/45/60

288 32 64 96 128 160 192 224 256

102.2 102.2 102.2 102.2 102.2 102.2 102.2 102.2 102.2

3 3 3 3 3 3 3 3 3

Drawer Ht 8 - W 90 3.8

Drawers Ht 16 W 45/60 W 90/120 3

Big drawers Ht 32 W 45/60 W 90/120/135/150/180 3

Under-bed big drawer Ht 24 - W 97.1 10.8

Folding Ht 32 W 45/60/90 W 120/135/150/180 3

Vasistas Ht 32 W 45/60/90 W 120/135/150/180 3

Drawers for inner drawer units Ht 16 - W 45/60/90 4.5

**Handle diagram**  
Span 96 mm

G62R G15B G14Y G68E G40S

Doors W 30/45/60

288 32 64 96 128 160 192 224 256

102.2 102.2 102.2 102.2 102.2 102.2 102.2 102.2 102.2

3 3 3 3 3 3 3 3 3

Drawer Ht 8 - W 90 3.8

Drawers Ht 16 W 45/60 W 90/120 3

Big drawers Ht 32 W 45/60 W 90/120/135/150/180 3

Under-bed big drawer Ht 24 - W 97.1 10.8

Folding Ht 32 W 45/60/90 W 120/135/150/180 3

Vasistas Ht 32 W 45/60/90 W 120/135/150/180 3

Drawers for inner drawer units Ht 16 - W 45/60/90 4.5

**Handle diagrams**  
Span 32 mm

G77Z G80K G31T G85C G61F

Doors W 30/45/60

288 32 64 96 128 160 192 224 256

102.2 102.2 102.2 102.2 102.2 102.2 102.2 102.2 102.2

3 3 3 3 3 3 3 3 3

Drawer Ht 8 - W 90 3.8

Drawers Ht 16 W 45/60 W 90/120 3

Big drawers Ht 32 W 45/60 W 90/120/135/150/180 3

Under-bed big drawer Ht 24 - W 97.1 10.8

Folding Ht 32 W 45/60/90 W 120/135/150/180 3

Vasistas Ht 32 W 45/60/90 W 120/135/150/180 3

Drawers for inner drawer units Ht 16 - W 45/60/90 4.5

**Handle diagram**  
Span 160 mm

G70T G21R G87K G28P G19Q G50F G58N G63W G79F  
G71B G52R G88N G53Z G51B G35F G59L G64Y G78C

Doors W 30/45/60

288 32 64 96 128 160 192 224 256

102.2 102.2 102.2 102.2 102.2 102.2 102.2 102.2 102.2

3 3 3 3 3 3 3 3 3

Drawer Ht 8 - W 90 3.8

Drawers Ht 16 W 45/60/90 W 120 3

Big drawers Ht 32 W 45/60/90 W 90/120/135/150/180 3

Under-bed big drawer Ht 24 - W 97.1 10.8

Folding Ht 32 W 45/60/90 W 120/135/150/180 3

Vasistas Ht 32 W 45/60/90 W 120/135/150/180 3

Drawers for inner drawer units Ht 16 - W 45/60/90 4.5

**Handle diagrams**  
Span 32 mm

G86F G75T G82T G49A

Doors W 30/45/60

288 32 64 96 128 160 192 224 256

102.2 102.2 102.2 102.2 102.2 102.2 102.2 102.2 102.2

7.8 7.8 7.8 7.8 7.8 7.8 7.8 7.8 7.8

3 3 3 3 3 3 3 3 3

Vertical on the doors

Drawer Ht 8 - W 90 3.8

Drawers Ht 16 W 45/60 W 90/120 7.8

Big drawers Ht 32 W 45/60 W 90/120/135/150/180 7.8

Under-bed big drawer Ht 24 - W 97.1 10.8

Folding Ht 32 W 45/60/90 W 120/135/150/180 7.8

Vasistas Ht 32 W 45/60/90 W 120/135/150/180 7.8

Drawers for inner drawer units Ht 16 - W 45/60/90 7.8

**Handle diagram**  
Span 160 mm

G81Q

Doors W 30/45/60

288 32 64 96 128 160 192 224 256

102.2 102.2 102.2 102.2 102.2 102.2 102.2 102.2 102.2

3 3 3 3 3 3 3 3 3

Drawer Ht 8 - W 90 X

Drawers Ht 16 W 45/60/90/120 X

Big drawers Ht 32 W 45/60/90/120/135/150/180 X

Under-bed big drawer Ht 24 - W 97.1 X

Folding Ht 32 W 45/60/90/120/135/150/180 X

Vasistas Ht 32 W 45/60/90/120/135/150/180 X

Drawers for inner drawer units Ht 16 - W 45/60/90 X

- X Handles cannot be fitted.
- \* Cannot be fitted on doors with cylinder lock.
- o Cannot be fitted on drawers Ht 8. Knobs BALL are supplied instead.

- VERTICAL handles
- HORIZONTAL handles

# Knob and handle positions

## Handle diagram Span 256 mm

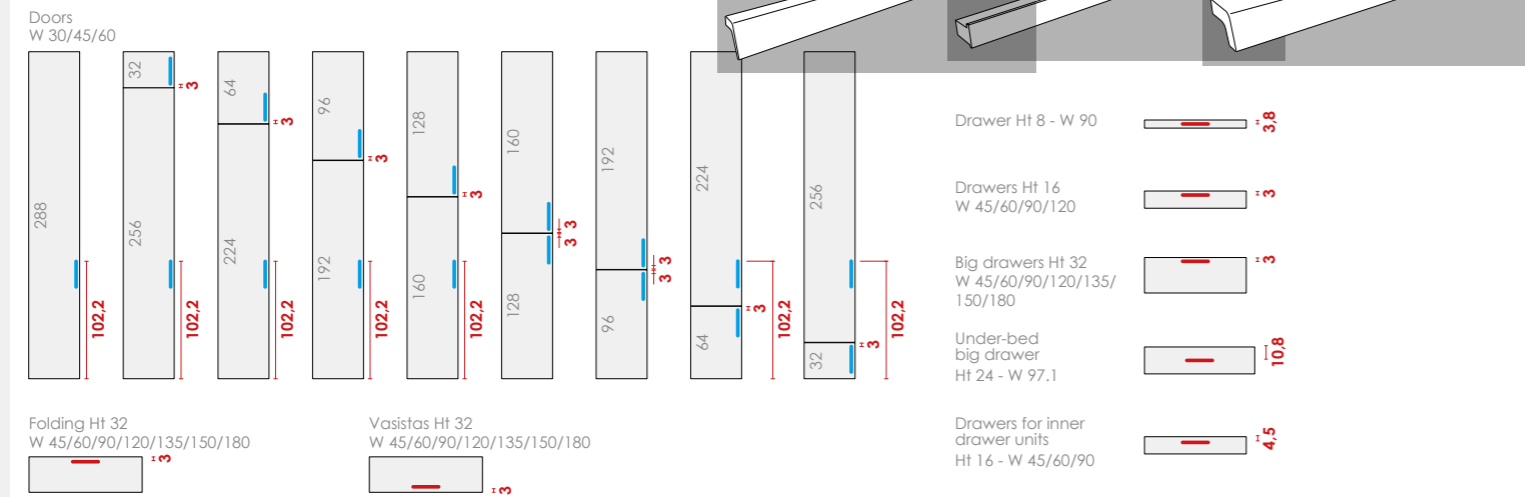

## Handle diagram Span 320 mm

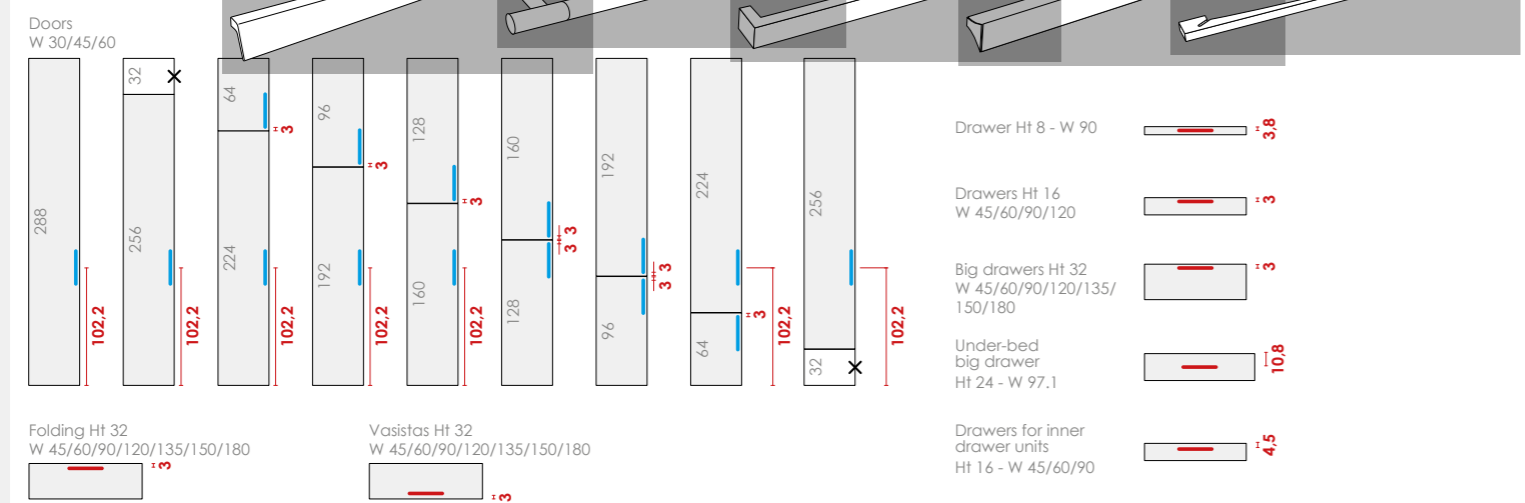

## Handle diagram Span 960 mm

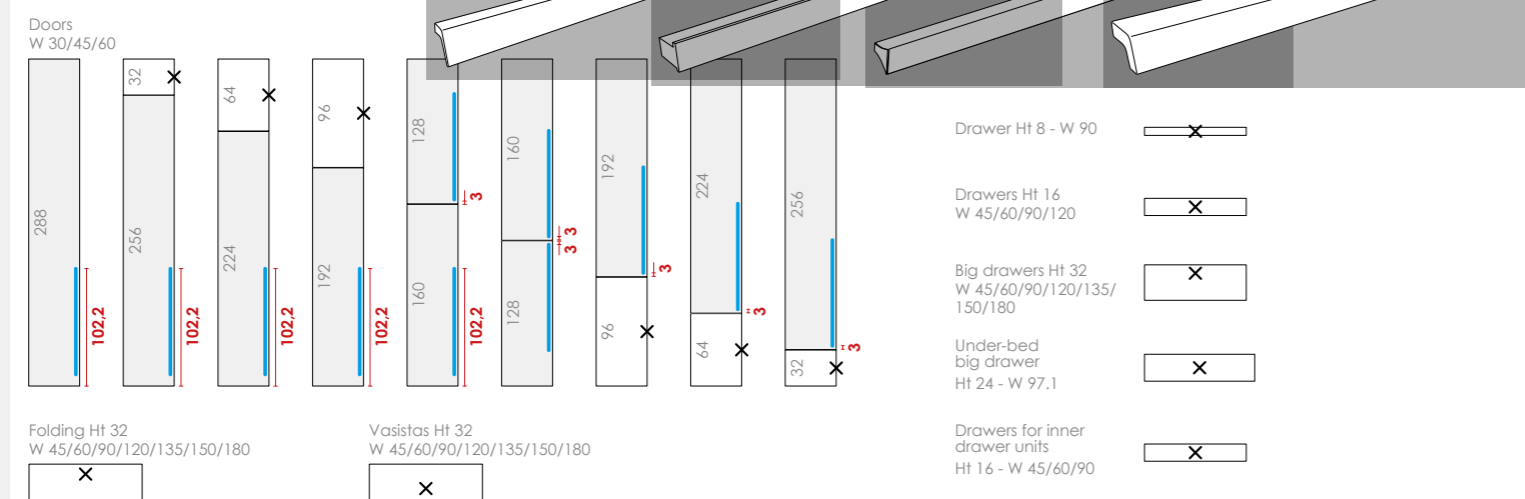

✗ Handles cannot be fitted.

VERTICAL handles  
HORIZONTAL handles



# Colour sample sets and paints for repairs

## Sample sets

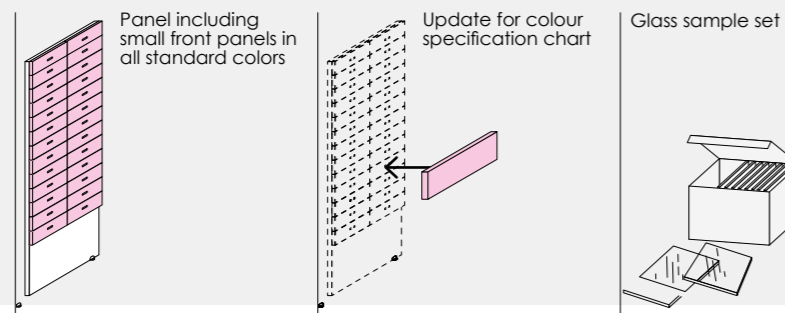

Code	Can be ordered from the "Point of Sale Materials" division		
------	--	--	--

## Paints for repairs

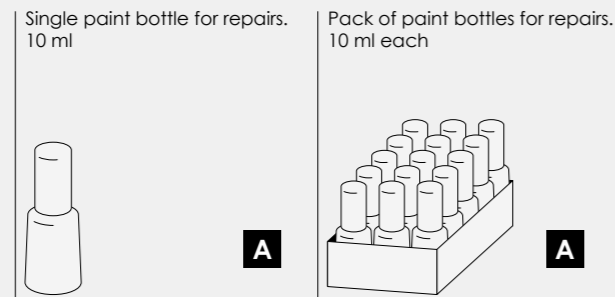

Code	P51.02Q	P51.08X		
------	---------	---------	--	--

## Paints in tins

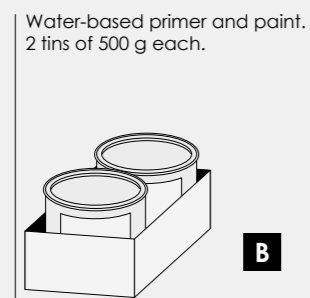

Code	P51.04A			
------	---------	--	--	--

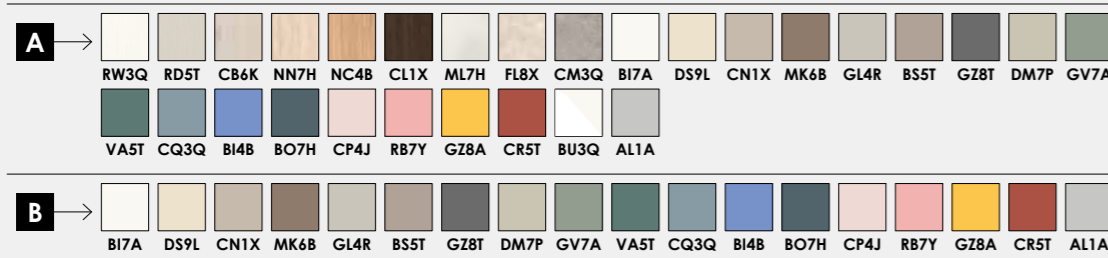

A photographic colour chart is provided at the beginning of the price list.

- Components in **CARCASE** colors
- Components in **GROUP 1** colors
- Components in **GROUP 2** colors

# Panels and edges

## Panels

N.B. The height of the panel is defined by the vertical wood vein pattern (if any).

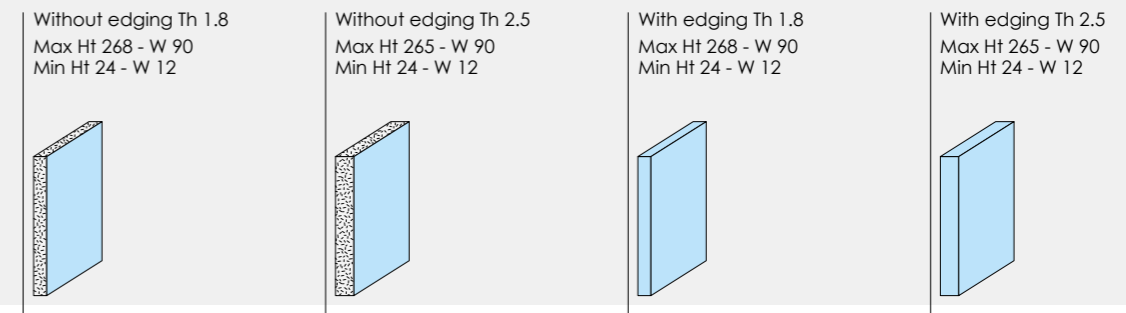

Code	P00.56U	P00.57Z	P00.58E	P00.59L
------	---------	---------	---------	---------

## Edgings

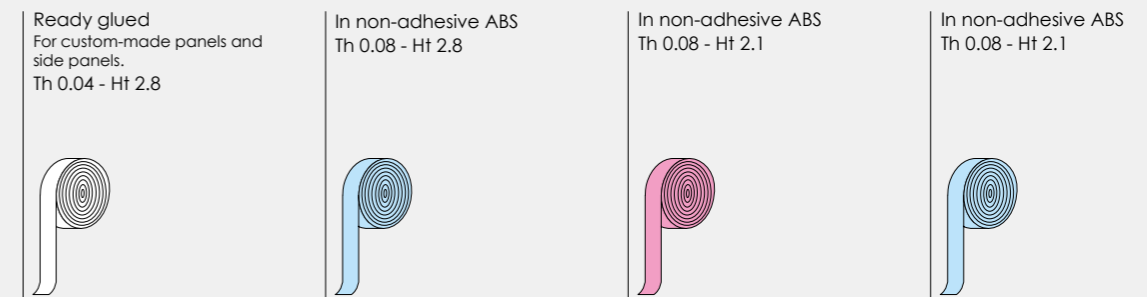

Code	P00.60R	P50.87Y	P00.66Y	PK00.06W
------	---------	---------	---------	----------

# Hardware

## Hinges with base plate

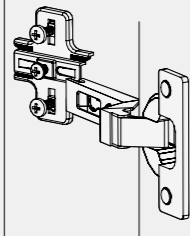

Decelerated

Description	Code	For use on:
110° hinge complete with base plate (2 pcs)	<b>P01.55S</b>	Doors for Wardrobes, Container Units and Modular Units.
hinge complete with base plate (2 pcs)	<b>P01.56X</b>	Ladder doors.
30° hinge complete with base plate (2 pcs)	<b>P01.57C</b>	Doors for end units Dpt. 56.3.
15° un concealed hinge complete with base plate (1 pc)	<b>P01.58H</b>	Doors for end units Dpt 45.
180° hinge complete with base plate (2 pcs)	<b>P01.59P</b>	Doors for corner wardrobe (not on WINDOW doors).
45° hinge complete with base plate (4 pcs)	<b>P01.60U</b>	Doors for walk-in wardrobes.
90° hinge complete with base plate (4 pcs)	<b>P01.61Z</b>	Doors for HAPPY walk-in wardrobes.

## Standard metal runners

Pair of runners for drawers and big drawers  
Dpt 56.3

Pair of runners for drawers and big drawers  
Dpt 45

Pair of runners for drawers  
Dpt 32.5

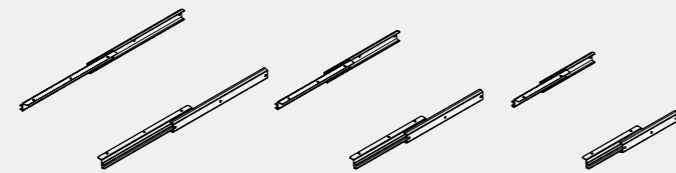

Description	Code	Code	Code
With slowed down	<b>P01.16E</b>	<b>P01.17L</b>	<b>P01.18R</b>

## Type "Quadro" height-adjustable metal runners

Pair of runners for drawers and big drawers CHARM  
Dpt 56.3

Pair of runners for drawers and big drawers CHARM  
Dpt 45

Pair of runners for drawers CHARM  
Dpt 32.5

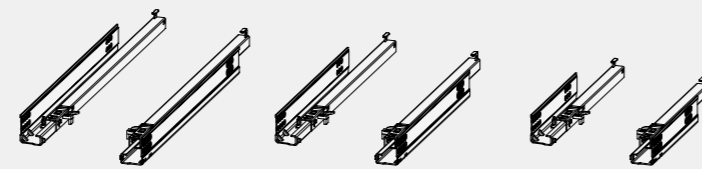

Description	Code	Code	Code
With slowed down	<b>P01.62E</b>	<b>P01.63L</b>	<b>P01.64R</b>
With push pull	<b>PK00.32M</b>	<b>PK00.35F</b>	<b>PK00.38A</b>
With slowed down and fully extractable	<b>PK00.33T</b>	<b>PK00.36N</b>	<b>PK00.39G</b>
With push pull and fully extractable	<b>PK00.34Z</b>	<b>PK00.37U</b>	<b>PK00.40D</b>

**Set soft opening/closing retainers for 2 sliding doors**  
2 retainers are required for each sliding door.



**Soft closing retainer for drawer and big drawer (for standard metal runners)**  
1 retainer is sufficient for each drawer W 45/60/90 and big drawer W 45/60. On big drawers W 90 2 soft closing systems are required.

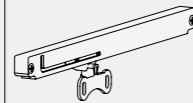

Code	P01.68N	P02.47B		

Components in GROUP 2 colors

**Bottom panel support Dpt 40**  
for drawers and big drawers

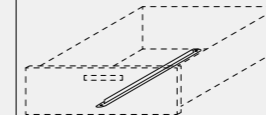

**Bottom panel support Dpt 50**  
for drawers and big drawers



**Adhesive hole cap**  
Set of 8 Ø 1,3

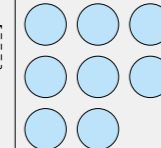

**Adhesive hole cap**  
Set of 8 Ø 2

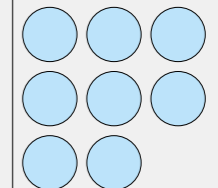

Code	P01.52A	P01.51V	P01.37U	P01.33X

**Concealed wheel pair**  
Self-braking.  
2 pieces

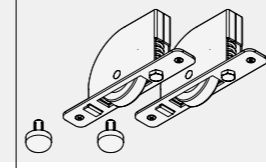

**Metal bed base support plates for beds and sofas**  
Set of 4

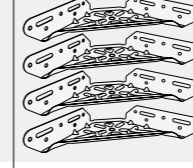

**Metal bed base support plates for BAIA sofa beds**  
Set of 4

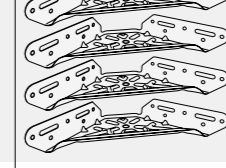

**Shelf holder for melamine-coated movable shelves**  
Set of 4

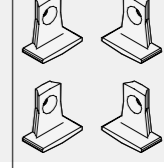

Code	P01.28V	P01.12H	PK00.41L	P01.10X

**Shelf holder for movable glass shelves**  
Set of 4

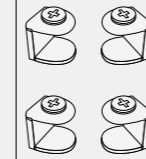

**Adjustable middle-support feet**  
2 pieces

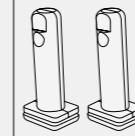

**Adjustable feet for wardrobes with sliding doors**  
Set of 4

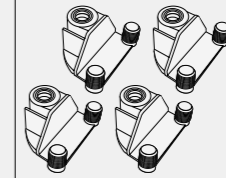

**Adjustable feet Ht 0.8 for INFINITY bookshelves**  
Set of 4

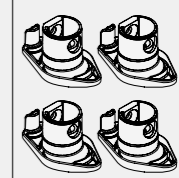

Code	P01.11C	P01.34C	P01.14U	P01.45N

**Adjustable feet Ht 0.7 for master bedrooms groups**  
Set of 4

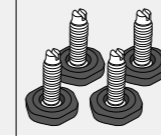

**Cylinder lock**  
For doors and drawers, complete with 2 grey keys.

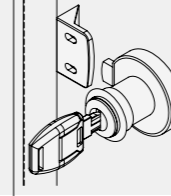

**Set of 5 lock cylinders for identical keys**  
Including cylinder removal key.

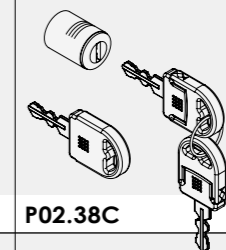

**Passepartout key**

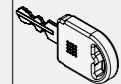

Code	P01.66B	P01.15Z	P02.38C	P02.39H

**Small hydraulic jack for push pull opening system**  
1 piece

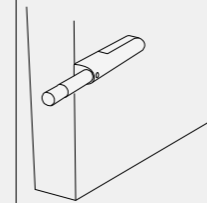

**Handle for doors WINDOW**  
Integrated in the aluminium frame.  
Ht 13

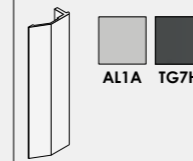

**Dust guard for hinged doors**  
Aluminium colour only.



Code	P01.44G	P01.69T	P01.13P	P01.70Y

# Miscellaneous

## Clothes hooks

### BOLLINO

Wall and panel clothes hook.  
Dpt 4 - Ø 10

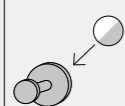

### TWIN

Wall and panel clothes hook.  
Ht 12.7 - W 3.4 - Dpt 5.2

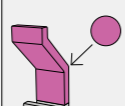

### POLE

Base and polypropylene parts black. Stand aluminium colour.  
Ø 40 - Ht 173



Code	P40.51A	P71.62V	P71.63A	
------	---------	---------	---------	--

## Pairs of shelf holders

### INCH

For shelves in frosted silk-screened glass only  
Dpt 5.7 - W 2.4



### LENA

Dpt 17 - Ht 8

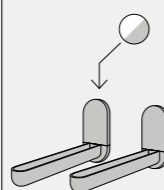

### GOLIA

Dpt 8.6 - W 4

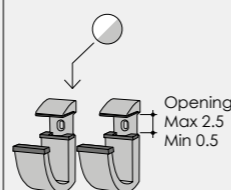

### SCACCO

Ht 10 - W 3.5

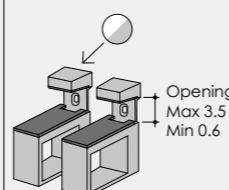

Code	P40.96V	PK61.14N	P40.52F	P71.68C
------	---------	----------	---------	---------

## Pairs of shelf holders

### INTEGRATED

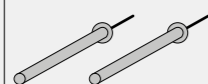

Code	P40.75F			
------	---------	--	--	--

## Various elements

### Bookend

In metal.  
Ht 17.8 - W 10 - Dpt 13.5

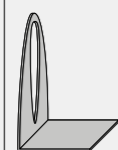

### HIP

Melamine-coated.  
Ht 29.4 - W 18 - Dpt 25

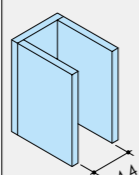

### HOP

Melamine-coated.  
Ht 29.4 - W 30 - Dpt 25

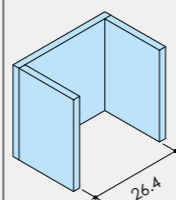

Code	P39.05C	P01.39E	P01.40L	
------	---------	---------	---------	--

## Castor wheels

### Small wheel Ø 6

Pack of 4  
Ht 8



Code	P07.72D			
------	---------	--	--	--

Components in **GROUP 2 colors**

Aluminium colour components

Complete with hardware for fixing to wall

Complete with hardware for fixing to panel  
In case of wall fixing the choice of hardware depends on the wall conditions and should be made by the assembler.

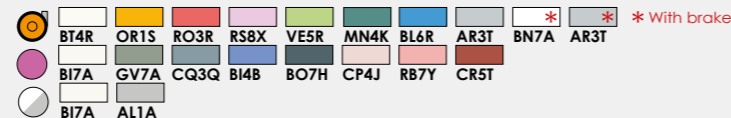

# Lighting

## Lighting with sensor

Complete kits with 1 Power pack.  
Cover color Aluminum and Titanium.

W 19,2

Dpt 11,2

Th 0,6

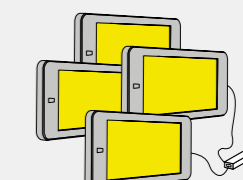
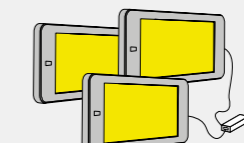
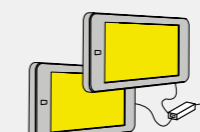

Code	P08.71B	P08.72G	P08.73N	P08.74T
------	---------	---------	---------	---------

### Led lamp SPARK

Manual switch or light sensor that can be operated with the side switch. Can be applied with the provided screws or with biadhesive Velcro. 3 - 1.5v AAA batteries not included.  
Ø 9.1 - Th 4.4

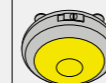

### Led lamp SKY

Built-in touch switch. Can be applied with the provided screws or with biadhesive tape. 3 - 1.5v AAA batteries not included.  
W 17 - Ht 2.2 - Dpt 1.5

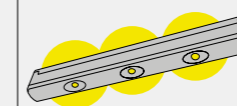

### Led light

For mounting on beds headboards or desks  
1.2 watt  
12V DC  
Current 90mA

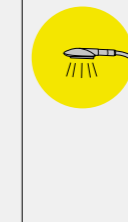

Code	P07.30A	P07.31F	P26.86F	
------	---------	---------	---------	--

### Led spotlights Ø 6.5

We provide a power pack (with a surcharge) able to support from 1 to 6 spotlights.  
12 volt 1.7 watt.

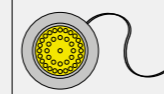

### Wireless switch

For led spotlights Ø 6.5.

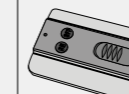

### Led lighting kit

Lamp in black coloured aluminium with front veil to reduce glare. K4000 natural light, right-hand side touch power-on, 24 V 240 led/metre, 20 Watt/metre, CE. Complete power kit and fastening screws.

Custom-made  
Max 220 cm Min 140 cm



Code	PL86.17N	PL86.18U	PK51.95K	
------	----------	----------	----------	--

# Tables and coffee tables

## NORMALE tables

Melamine-coated top and frame, legs in wood.

Colors:



Code	PK00.46T	PK00.47Z	PK00.48F
------	----------	----------	----------

### Square extending

Ht 78,6  
W 90 (180)  
Dpt 90

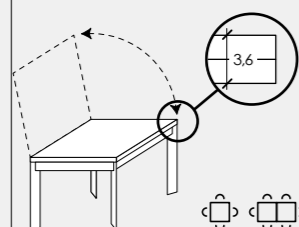

### Fixed rectangular

Ht 77,5  
W 160  
Dpt 85

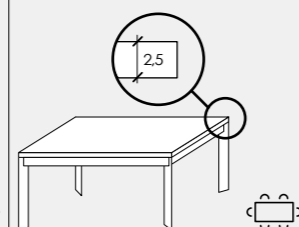

### Extensible rectangular

Ht 77,5  
W 160 (200)  
Dpt 85

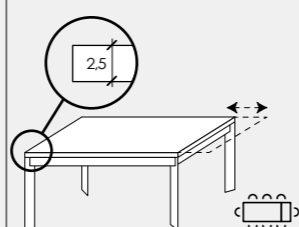

## Coffee tables

Top Th 2.5 and frame Th 1.8 melamine-coated.

### Square

Ht 44  
W 70  
Dpt 70

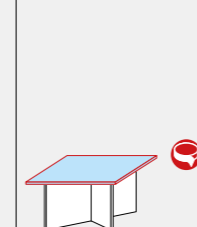

### Round

Ht 44  
Ø 85

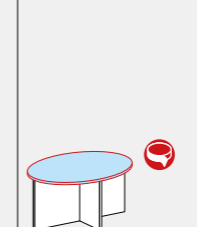

Code	P52.53V	P52.09F
------	---------	---------

## FLAT tables

Melamine-coated.

Colors:



Code	PK00.49N	PK00.50K	PK00.51R	PK00.52X
------	----------	----------	----------	----------

### Fixed rectangular

Ht 78  
W 130  
Dpt 90

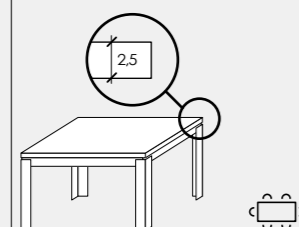

### Extensible rectangular

Ht 78  
W 130 (180)  
Dpt 90

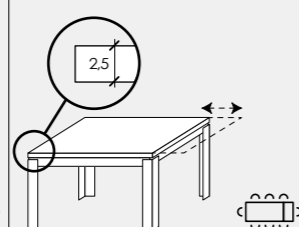

### Fixed rectangular

Ht 78  
W 160  
Dpt 90

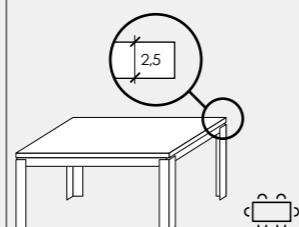

### Extensible rectangular

Ht 78  
W 160 (210)  
Dpt 90

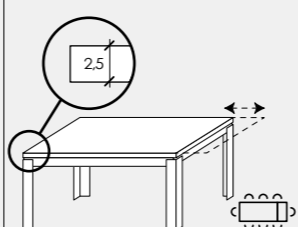

## TWIG coffee table

Lacquered top Th 2.5. Legs in solid natural ash wood.

Ht 44  
Ø 34

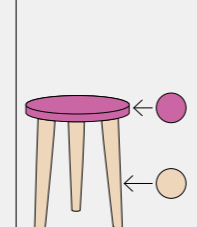

Code	PK50.06N
------	----------

## GALIZIA table

Extending table with double extensions (W 50 cm each). Melamine top Th 1.8 (folded Th 8). MDF legs in finishes matching the top.

Colors:



Code	PK00.19W
------	----------

### Extensible rectangular

Ht 77  
W 180 (280)  
Dpt 90

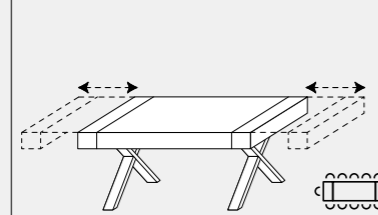

## TONDO table

Melamine top Th 2.5. Pedestal, both in aluminium colour metal (AL1A).

Ht 72  
Ø 110

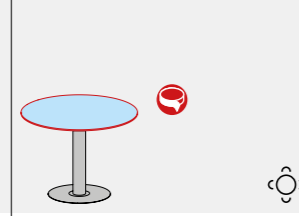















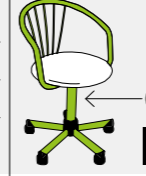





Code	P65.35K
------	---------

- Components in **CARCASE** colors
- Components in **GROUP 2** colors
- B17A GV7A CQ3Q B14B BO7H CP4J RB7Y CR5T
- Shaped components available with contrasting edging.
- Solid natural ash wood**  
Wood is a natural product and, as such, is subject to variations in color and grain. Differences in grain or color therefore do not constitute grounds for dispute.



# Chairs and armchairs for study area

	<p><b>BENNA</b> Seats Structure and shell in nylon.</p>  <p>Ht 80 Dpt 51 W 59 Ht seat 45</p> <p><b>A</b></p>	<p><b>BREDA</b> Polypropylene body.</p>  <p>Ht 82 Dpt 54 W 51 Ht seat 47</p> <p><b>B</b></p>	<p><b>BREDA</b> With wheels and swivel Polypropylene body and self-braking wheels.</p>  <p>Ht adjust. Dpt 62 W 51 Ht seat 45+54</p> <p><b>B</b></p>	<p><b>FLO</b> Seats Wooded structure in Ciliegio bianco finish CB6K). MDF seat.</p>  <p>Ht 87 Dpt 48 W 39,5 Ht seat 45</p>	<p><b>FLO</b> Stools Wooded structure in Ciliegio bianco finish CB6K). MDF seat.</p>  <p>Ht 45 Dpt 33 W 33</p>	<p><b>FRUIT</b> With wheels and swivel base Shell in polypropylene and padded bottom.</p>  <p>Ht adjust. Dpt 54 W 48 Ht seat 45+54</p> <p><b>C</b></p>	<p><b>GIROTONDO</b> With wheels and swivel base Metal structure and fabric seat.</p>  <p>Ht 93 Dpt 55 W 55 Ht seat 45,3+60</p> <p><b>D</b></p>	
<b>Code</b>	<b>PK00.42S</b>	<b>P94.11G</b>	<b>P94.12N</b>	<b>PL03.22W</b>	<b>PL03.23C</b>	<b>PL03.07T</b>	<b>PL03.20H</b>	
	<p><b>LUNA</b> Polypropylene body.</p>  <p>Ht 80 Dpt 52 W 54 Ht seat 45</p> <p><b>E</b></p>	<p><b>LUNA</b> With cushion Polypropylene body.</p>  <p>Ht 80 Dpt 52 W 54 Ht seat 45</p> <p><b>E</b></p>	<p><b>LUNA</b> With wheels Polypropylene body.</p>  <p>Ht 79 Dpt 70 W 70 Ht seat 45,5</p> <p><b>E</b></p>	<p><b>LUNA</b> With wheels and cushion Polypropylene body.</p>  <p>Ht 79 Dpt 70 W 70 Ht seat 45,5</p> <p><b>E</b></p>	<p><b>NICE</b> Seats Structure and seat in propylene.</p>  <p>Ht 83 Dpt 52 W 43 Ht seat 46</p> <p><b>F</b></p>	<p><b>SOFT</b> With wheels and swivel Eco-leather shell and black coloured support with wheels.</p>  <p>Ht adjust. Dpt 65 W 60 Ht seat 45+58</p> <p><b>G</b></p>	<p><b>STEP</b> Polypropylene body.</p>  <p>Ht 80 Dpt 55 W 50,5 Ht seat 46,5</p> <p><b>H</b></p>	
<b>Code</b>	<b>PK00.09R</b>	<b>PK00.10N</b>	<b>PK00.11U</b>	<b>PK00.07C</b>	<b>PK00.43Y</b>	<b>P94.99L</b>	<b>PK00.08K</b>	
	<p><b>TRAK</b> With wheels and swivel base Metal structure and thermoformed polypropylene shell.</p>  <p>Ht 92,5 Dpt 60 W 60 Ht seat 42+55</p> <p><b>I</b></p>	<p><b>WOODY</b> White cotta Padded seat covered in eco-leather on seat.</p>  <p>Ht 85 Dpt 45 W 42 Ht seat 43,5</p> <p><b>L</b></p>						
<b>Code</b>	<b>PL03.21Q</b>	<b>PL03.13X</b>						
<b>Office chairs</b> Black frames and wheels.	<p><b>Chair</b> Without armrests.</p>  <p>Ht 80 Dpt 60 W 53 Ht seat 46</p> <p><b>M</b></p>	<p><b>Chair</b> With armrests.</p>  <p>Ht 80 Dpt 60 W 63 Ht seat 46</p> <p><b>M</b></p>	<p><b>Armchair</b> With wheels and swivel With pneumatic suspension, without armrests. Ht back Min 90 Max 103.</p>  <p>Ht adjust. Dpt 65 W 64 Ht seat 44+57</p> <p><b>M</b></p>	<p><b>Armchair</b> With wheels and swivel With pneumatic suspension and armrests. Ht back Min 90 Max 103.</p>  <p>Ht adjust. Dpt 65 W 64 Ht seat 44+57</p> <p><b>M</b></p>				
<b>Code</b>	<b>P65.11D</b>	<b>P65.10Y</b>	<b>P65.09T</b>	<b>P65.08N</b>				

<b>A</b>	Nylon K34C K35F K36K K37N
<b>B</b>	Polypropylene K01P K02S K03V K04Y K05B K06E K07H
<b>C</b>	Polypropylene Z30R Z38R Z31L Z32B Z33W Z34U Z39A Z40T
<b>D</b>	Fabric X22K
<b>E</b>	Polypropylene K28F K29K K30N K31T Cushion cover Z86Y Z87B
<b>F</b>	Polypropylene K38R K39U K40X By ordering the K39U (Sabbia Nice) the chair will be two-coloured, with a white seat and back and a sand-coloured structure.
<b>G</b>	Faux leather Z24B Z25H Z26N Z27R Z28W
<b>H</b>	Polypropylene K32W K33Z
<b>I</b>	Polypropylene Y33R Z13K Z15L Z14G Z35F Z16R
<b>L</b>	Wooden frame RW3Q RD5T CB6K NC4B CL1X B17A CN1X Faux leather Z56W Z57T Z58R Z59K
<b>M</b>	BERLIN fabric BE01 BE02 BE03 BE04 BE05 BE06 BE07

Aluminium colour components  
 B17A GZ8T GV7A CQ3Q B14B BO7H CP4J RB7Y CR5T AL1A  
 Products made with flame retardant components.  
 CLASS 1 IM (UNI 9175/76)

A photographic colour chart is provided at the beginning of the price list.

# Doors



W 30	Reference images →	Ht 32 2 hinges										* Only one door is with handle				
		PL26.00S	PL26.01Y	PL26.02E	PL26.03M	PL26.04T	PL26.05Z	PL26.06F	PL26.07N	PK00.20T	-	-	-			
ONE	matte															
ONE	glossy															
CLUB																
WINDOW																
W 45		P50.15G	P50.17T	P50.19D	P50.21Q	P50.23A	P50.25M	P50.10E	P50.12R	PK00.21Z	-	-	-			
ONE	matte															
ONE	glossy															
CLUB																
WINDOW																
W 60		P26.00P	P26.01U	P26.03E	P26.05R	P26.07B	P26.09N	P26.11Y	P26.13K	PK00.22F	PL26.08U	PL26.09A	PL26.10X			
ONE	matte															
ONE	glossy															
CLUB																
WINDOW																
W 90	Reference images →	* Only one door is with handle										* Handle positioned on the W 60 door				
		P50.27X	P50.29H	P50.31U	P50.33E	P50.35R	P50.37B	P50.14B	P50.16N	PK00.23N	PL26.20C	PL26.21K	PL26.22R			
ONE	matte															
ONE	glossy															
CLUB																
WINDOW																
W 120		PL26.31Q	PL26.32W	PL26.33C	PL26.34K	PL26.35R	PL26.36X	PL26.37D	PL26.38L	PK00.24U	-	-	-			
ONE	matte															
ONE	glossy															
CLUB																
WINDOW																

- Components in **Types and colors FRONT**
- Doors W 30**
- Doors W 30 + W 60** - Indicate R or L (drawing - R)

- The doors are equipped with hinges decelerate.
- Upon request, the doors can be supplied without a handle and without handle holes (not on CLUB and WINDOW).
- Pairs of CLUB doors are provided only with one handle. Upon customer's request the CLUB handle can be mounted on both doors.





## W 30

Specify hinge  
R or L

*\* Only one door is with handle*

Reference images →

**With cylinder lock**  
for Wardrobes, Container units and Modular units

<b>Code</b>	-	-	-	-	-	-	-	-	-	-	-	-	-	-
ONE	matte	-	-	-	-	-	-	-	-	-	-	-	-	-
	glossy	-	-	-	-	-	-	-	-	-	-	-	-	-
CLUB	-	-	-	-	-	-	-	-	-	-	-	-	-	-
WINDOW	-	-	-	-	-	-	-	-	-	-	-	-	-	-

## W 45

Specify hinge  
R or L

<b>Code</b>	-	-	-	-	-	-	-	<b>P50.82WB</b>	<b>P50.82WP</b>	<b>P50.18YB</b>	<b>P50.18YP</b>	<b>P50.20KB</b>	<b>P50.20KP</b>
ONE	matte	-	-	-	-	-	-	-	-	-	-	-	-
	glossy	-	-	-	-	-	-	-	-	-	-	-	-
CLUB	-	-	-	-	-	-	-	-	-	-	-	-	-
WINDOW	-	-	-	-	-	-	-	-	-	-	-	-	-

## W 60

Specify hinge  
R or L

<b>Code</b>	<b>PL26.11D</b>	<b>PL26.12L</b>	<b>PL26.13S</b>	<b>PL26.14Y</b>	<b>PL26.15E</b>	-	<b>PK00.25A</b>	<b>P26.15VB</b>	<b>P26.15VP</b>	<b>P26.17FB</b>	<b>P26.17FP</b>	<b>P26.19SB</b>	<b>P26.19SP</b>
ONE	matte	-	-	-	-	-	-	-	-	-	-	-	-
	glossy	-	-	-	-	-	-	-	-	-	-	-	-
CLUB	-	-	-	-	-	-	-	-	-	-	-	-	-
WINDOW	-	-	-	-	-	-	-	-	-	-	-	-	-

## W 90

*\* Handle positioned on the W 60 door*

Reference images →

**With cylinder lock**  
for Wardrobes, Container units and Modular units

<b>Code</b>	<b>PL26.23X</b>	<b>PL26.24D</b>	<b>PL26.25L</b>	<b>PL26.26S</b>	<b>PL26.27Y</b>	-	<b>PK00.26G</b>	<b>P50.83BB</b>	<b>P50.83BP</b>	<b>P50.38GB</b>	<b>P50.38GP</b>	<b>P50.40TB</b>	<b>P50.40TP</b>
ONE	matte	-	-	-	-	-	-	-	-	-	-	-	-
	glossy	-	-	-	-	-	-	-	-	-	-	-	-
CLUB	-	-	-	-	-	-	-	-	-	-	-	-	-
WINDOW	-	-	-	-	-	-	-	-	-	-	-	-	-

## W 120

<b>Code</b>	-	-	-	-	-	-	-	<b>P64.91LB</b>	<b>P64.91LP</b>	<b>P64.92RB</b>	<b>P64.92RP</b>	<b>P64.93WB</b>	<b>P64.93WP</b>
ONE	matte	-	-	-	-	-	-	-	-	-	-	-	-
	glossy	-	-	-	-	-	-	-	-	-	-	-	-
CLUB	-	-	-	-	-	-	-	-	-	-	-	-	-
WINDOW	-	-	-	-	-	-	-	-	-	-	-	-	-

- Components in **Types and colors FRONT**
- Doors W 30**
- Doors W 30 + W 60** - Indicate R or L (drawing - R)

- The doors are equipped with hinges decelerate.
- Upon request, the doors can be supplied without a handle and without handle holes (not on CLUB and WINDOW).
- Pairs of CLUB doors are provided only with one handle. Upon customer's request the CLUB handle can be mounted on both doors.



# Doors

## W 30

Specify hinge  
R or L

	With cylinder lock for Wardrobes, Container units and Modular units					With bar lock For wardrobes Dpt 57.1 only							
	Reference images →	Lock AT TOP Ht 128 3 hinges	Lock AT BOTTOM Ht 128 3 hinges	Lock AT TOP Ht 160 3 hinges	Lock AT BOTTOM Ht 160 3 hinges	Ht 192 4 hinges	Ht 192 4 hinges	Ht 224 4 hinges	Ht 256 4 hinges				
<b>Code</b>	-	-	-	-	-	-	-	-	-				
ONE <span style="margin-left: 20px;">matte</span>	-	-	-	-	-	-	-	-	-				
ONE <span style="margin-left: 20px;">glossy</span>	-	-	-	-	-	-	-	-	-				
CLUB	-	-	-	-	-	-	-	-	-				
WINDOW	-	-	-	-	-	-	-	-	-				

## W 45

Specify hinge  
R or L

<b>Code</b>	<b>P50.36WB</b>	<b>P50.36WP</b>	<b>P50.00AB</b>	<b>P50.00AP</b>	<b>P50.76P</b>		*	*	*				
ONE <span style="margin-left: 20px;">matte</span>													
ONE <span style="margin-left: 20px;">glossy</span>													
CLUB													
WINDOW													

## W 60

Specify hinge  
R or L

<b>Code</b>	<b>P26.21CB</b>	<b>P26.21CP</b>	<b>P26.23PB</b>	<b>P26.23PP</b>	<b>P26.25Z</b>		*	*	*				
ONE <span style="margin-left: 20px;">matte</span>													
ONE <span style="margin-left: 20px;">glossy</span>													
CLUB													
WINDOW													

## W 90

	With cylinder lock for Wardrobes, Container units and Modular units					With bar lock For wardrobes Dpt 57.1 only							
	Reference images →	Lock AT TOP Ht 128 6 hinges	Lock AT BOTTOM Ht 128 6 hinges	Lock AT TOP Ht 160 6 hinges	Lock AT BOTTOM Ht 160 6 hinges	Ht 192 8 hinges	Ht 192 8 hinges	Ht 224 8 hinges	Ht 256 8 hinges				
<b>Code</b>	<b>P50.34LB</b>	<b>P50.34LP</b>	<b>P51.00DB</b>	<b>P51.00DP</b>	<b>P51.76S</b>		*	*	*				
ONE <span style="margin-left: 20px;">matte</span>													
ONE <span style="margin-left: 20px;">glossy</span>													
CLUB													
WINDOW													

## W 120

<b>Code</b>	<b>P64.94BB</b>	<b>P64.94BP</b>	<b>P64.95GB</b>	<b>P64.95GP</b>	<b>P64.96S</b>		*	*	*				
ONE <span style="margin-left: 20px;">matte</span>													
ONE <span style="margin-left: 20px;">glossy</span>													
CLUB													
WINDOW													

Components in **Types and colors FRONT**

\* UNCODED DOORS. When ordering, state the code of the wardrobe it is to be combined with.

# On units D 56.3 use a removable dividing shelf D 53.

• The doors are equipped with hinges decelerate.





## Doors for over-bar wardrobe of RIALTO bridge unit

## Door panel without holes for hinges and handles

### W 30

Specify hinge  
R or L

Reference  
images →

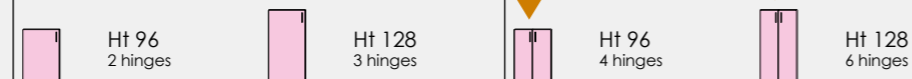

\* Only one door  
is with handle

Code	PL26.52G	PL26.53P	-	-
ONE	matte			
	glossy			
CLUB				

### W 45

Specify hinge  
R or L

Code	PL26.55B	PL26.56H	-	-
ONE	matte			
	glossy			
CLUB				

### W 60

Specify hinge  
R or L

Code	PL26.58W	PL26.59C	PL26.65G	PL26.66P
ONE	matte			
	glossy			
CLUB				

\* Only one door  
is with handle

\* Handle positioned on  
the W 60 door

Reference  
images →

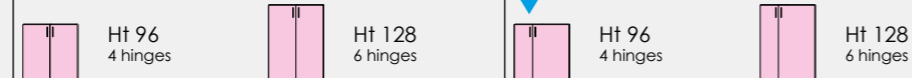

### W 90

Code	PL26.62N	PL26.63U	PL26.67V	PL26.68B
ONE	matte			
	glossy			
CLUB				

### Th 1.8

Always state the  
height (Ht) and  
width (W) of the  
door panel

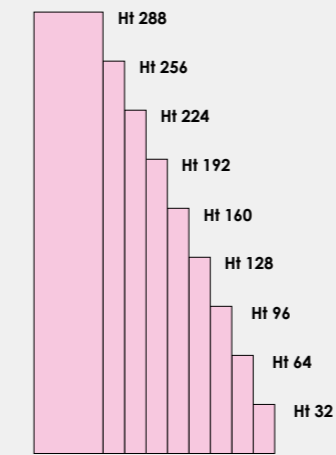

Code		P51.63W		
		W 29.7 (30)	W 44.7 (45)	W 59.7 (60)
Ht 31.6 (32)	ONE	matte		
		glossy		
	CLUB			
Ht 63.6 (64)	ONE	matte		
		glossy		
	CLUB			
Ht 95.6 (96)	ONE	matte		
		glossy		
	CLUB			
Ht 127.6 (128)	ONE	matte		
		glossy		
	CLUB			
Ht 159.6 (160)	ONE	matte		
		glossy		
	CLUB			
Ht 191.6 (192)	ONE	matte		
		glossy		
	CLUB			
Ht 223.6 (224)	ONE	matte		
		glossy		
	CLUB			
Ht 255.6 (256)	ONE	matte		
		glossy		
	CLUB			
Ht 255.6 (256)	ONE	matte		
		glossy		
	CLUB			

Components in **Types and colors FRONT**

Doors W 30

Doors W 30 + W 60 - Indicate R or L (drawing - R)

- The doors are equipped with hinges decelerate.
- Upon request, the doors can be supplied without a handle and without handle holes (not on CLUB).
- Pairs of CLUB doors are provided only with one handle. Upon customer's request the CLUB handle can be mounted on both doors.

# Drawers and big drawers



		Dpt 51.8 for elements Dpt 56.3					Dpt 41.8 for elements Dpt 45				
<b>W 45</b>	Reference images →	Ht 16 1 drawer	Ht 16 2 drawers	Ht 16 4 drawers	Ht 16 1 big drawer	Ht 16 2 big drawers	Ht 16 1 drawer	Ht 16 2 drawers	Ht 16 4 drawers	Ht 16 1 big drawer	Ht 16 2 big drawers
	<b>Code</b>	<b>P50.39NA</b>	<b>P50.41YA</b>	<b>P50.47FA</b>	<b>P51.33H</b>	<b>P51.35U</b>	<b>P50.22VB</b>	<b>P50.26SB</b>	<b>P50.30PB</b>	<b>P51.95V</b>	<b>P51.96A</b>
	ONE	matte									
	CLUB	glossy									
<b>W 60</b>	<b>Code</b>	<b>P26.42S</b>	<b>P26.43X</b>	<b>P26.44C</b>	<b>P26.45H</b>	<b>P26.46P</b>	<b>P26.54G</b>	<b>P26.55N</b>	<b>P26.56T</b>	<b>P26.57Y</b>	<b>P26.58D</b>
	ONE	matte									
	CLUB	glossy									
	CLUB										
<b>W 90</b>	Reference images →	Ht 16 1 drawer	Ht 16 2 drawers	Ht 16 4 drawers	Ht 16 1 big drawer	Ht 16 2 big drawers	Ht 16 1 drawer	Ht 16 2 drawers	Ht 16 4 drawers	Ht 16 1 big drawer	Ht 16 2 big drawers
	<b>Code</b>	<b>P50.46AA</b>	<b>P50.43KA</b>	<b>P50.49SA</b>	<b>P51.37E</b>	<b>P51.39R</b>	<b>P50.24FB</b>	<b>P50.28CB</b>	<b>P50.32ZB</b>	<b>P51.97F</b>	<b>P51.98M</b>
	ONE	matte									
	CLUB	glossy									
<b>W 120</b>	<b>Code</b>	<b>PL26.41V</b>	<b>PL26.42B</b>	<b>PL26.43H</b>	<b>PL26.47K</b>	<b>PL26.48R</b>	<b>PL26.44Q</b>	<b>PL26.45W</b>	<b>PL26.46C</b>	<b>PL26.49X</b>	<b>PL26.50U</b>
	ONE	matte									
	CLUB	glossy									
	CLUB										









Drawers and big drawers CHARM with "Quadro" soft rails as standard (without surcharges)

Components in **Types and colors FRONT**

- For drawers and big drawers with closing retainers, specify the code of the unit with which they are to be combined since it is necessary to make special holes.

**CLUB**  
drawers and big drawers CHARM with soft-close "Quadro" type slides as standard (without surcharges)

# Drawers and big drawers

		Dpt 41.8 for elements Dpt 45	Dpt 29.8 for elements Dpt 32.5								
<b>W 45</b>	Reference images →		 Ht 16 1 drawer	 Ht 16 2 drawers	 Ht 16 4 drawers		 Ht 16 1 big drawer	 Ht 16 2 big drawers			
	<b>Code</b>	-	<b>P52.31AC</b>	<b>P52.32FC</b>	<b>P52.34SC</b>		<b>P94.87V</b>	<b>P94.88A</b>			
	ONE matte	-									
	ONE glossy	-									
CLUB	-										
<b>W 60</b>	<b>Code</b>	-	<b>P52.69G</b>	<b>P52.70N</b>	<b>P52.74K</b>		<b>P94.89F</b>	<b>P94.90M</b>			
	ONE matte	-									
	ONE glossy	-									
	CLUB	-									
<b>W 90</b>	Reference images →	 Ht 8 1 drawer	 Ht 16 1 drawer	 Ht 16 2 drawers	 Ht 16 4 drawers		 Ht 16 1 big drawer	 Ht 16 2 big drawers			
	<b>Code</b>	*	<b>P52.41EC</b>	<b>P52.42LC</b>	<b>P52.44WC</b>		<b>P94.91S</b>	<b>P94.92X</b>			
	ONE matte										
	ONE glossy										
CLUB											
<b>W 120</b> Drawers and big drawers CHARM with "Quadro" soft rails as standard (without surcharges)	<b>Code</b>	-	-	-	-		-	-			
	ONE matte	-	-	-	-		-	-			
	ONE glossy	-	-	-	-		-	-			
	CLUB	-	-	-	-		-	-			

 Components in **Types and colors FRONT**

- \* **Drawers Ht 8 not codified.** Specify in the order the code of the unit with which they are to be combined. NB. with these drawers, it is not possible to make compositions different from those already present on the price list.
- For drawers and big drawers with closing retainers, specify the code of the unit with which they are to be combined since it is necessary to make special holes.

**CLUB**  
drawers and big drawers CHARM with soft-close "Quadro" type slides as standard (without surcharges)

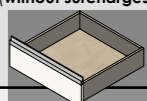

**GROUP 1 colors**

**GROUP 2 colors**

**GROUP 3 colors**

**CARCASE colors**

Rovere Dorian <b>RD5T</b>	Rovere white <b>RW3Q</b>	Noce naturale <b>NN7H</b>	Eucalipto <b>CL1X</b>	Domy <b>DM7P</b>	Bianco UV <b>BU3Q</b>
Ciliegio bianco <b>CB6K</b>	Malta <b>ML7H</b>	Feltro <b>FL8X</b>	Cemento Masdar <b>CM3Q</b>	Blu indaco <b>BI4B</b>	
Noce <b>NC4B</b>	Desert <b>DS9L</b>	Canapa <b>CN1X</b>	Moka <b>MK6B</b>	Cipria <b>CP4J</b>	
Bianco opaco <b>BI7A</b>	Grigio Dorian <b>GL4R</b>	Basalto <b>BS5T</b>	Grigio titanio <b>GZ8T</b>	Rosa bubble <b>RB7Y</b>	
	Agave <b>GV7A</b>	Verde Alpi <b>VA5T</b>	Cadaques <b>CQ3Q</b>	Giallo zafferano <b>GZ8A</b>	
	Blu opale <b>BO7H</b>			Corallo <b>CR5T</b>	

**Types and colors FRONT**

**ONE**

matte

glossy

Rovere white <b>RW3Q</b>	Rovere Dorian <b>RD5T</b>	Ciliegio bianco <b>CB6K</b>	Noce naturale <b>NN7H</b>	Noce <b>NC4B</b>	Eucalipto <b>CL1X</b>	Malta <b>ML7H</b>
Feltro <b>FL8X</b>	Cemento Masdar <b>CM3Q</b>	Bianco opaco <b>BI7A</b>	Desert <b>DS9L</b>	Canapa <b>CN1X</b>	Moka <b>MK6B</b>	Grigio Dorian <b>GL4R</b>
Basalto <b>BS5T</b>	Grigio titanio <b>GZ8T</b>	Domy <b>DM7P</b>	Agave <b>GV7A</b>	Verde Alpi <b>VA5T</b>	Cadaques <b>CQ3Q</b>	Blu indaco <b>BI4B</b>
Blu opale <b>BO7H</b>	Cipria <b>CP4J</b>	Rosa bubble <b>RB7Y</b>	Giallo zafferano <b>GZ8A</b>	Corallo <b>CR5T</b>		

Bianco UV  
**BU3Q**

**CLUB**

Specify the color of the CLUB handle

Bianco opaco <b>BI7A</b>	Desert <b>DS9L</b>	Canapa <b>CN1X</b>	Moka <b>MK6B</b>	Grigio Dorian <b>GL4R</b>	Basalto <b>BS5T</b>	Grigio titanio <b>GZ8T</b>
Domy <b>DM7P</b>	Agave <b>GV7A</b>	Verde Alpi <b>VA5T</b>	Cadaques <b>CQ3Q</b>	Blu indaco <b>BI4B</b>	Blu opale <b>BO7H</b>	Cipria <b>CP4J</b>
Rosa bubble <b>RB7Y</b>	Giallo zafferano <b>GZ8A</b>	Corallo <b>CR5T</b>				

**WINDOW**

Trasparente  
**TR9M**

Trasparente fumé  
**FT8P**

Stop-sol  
**ST6P**

Specchio  
**SP7L**

Specify the color of the aluminum frame

Alluminio <b>AL1A</b>	Titan grey <b>TG7H</b>
--------------------------	---------------------------

**Wardrobes hinged doors**

Wardrobes - technical information	84
OPTIONAL for wardrobes	86
Made-to-measure solutions for hinged doors	88
Wardrobes Ht 193.6 - Dpt 56.3	90
Wardrobes Ht 193.6 - Dpt 56.3 - with niche	94
Wardrobes Ht 225.6 - Dpt 56.3	96
Wardrobes Ht 225.6 - Dpt 56.3 - with niche	100
Wardrobes Ht 241.6 - Dpt 56.3	102
Wardrobes Ht 241.6 - Dpt 56.3 - with niche	106
Wardrobes Ht 257.6 - Dpt 56.3	108
Wardrobes Ht 257.6 - Dpt 56.3 - with niche	112
Wardrobes Ht 289.6 - Dpt 56.3	114
Wardrobe compositions Dpt 56.3	118
Wardrobes Dpt 56.3 with fixed TV stand element	124
Wardrobes Dpt 56.3 with openable TV stand element	126
Wardrobes Dpt 56.3 with pull-out desk	128
Over-door wardrobe Dpt 56.3	130
Accessories for wardrobe Dpt 56.3	132
Corner wardrobe units Dpt 56.3 - W 99.6 x 101.3	136
Corner wardrobes Dpt 56.3 - W 90 with opening door W 45	138
Corner wardrobes Dpt 56.3 - W 90 with opening door W 60	140
External corner wardrobes Dpt 56.3 - W 56.3	142
Filler strip 5.4 - 5.4 (for empty corners)	144
End units Dpt 56.3 - W 40	146
LOGIK end bookshelves	148
VELA end bookshelves L 30.7 - Dpt 54	150
QUID end bookshelves	152
SMART end bookshelves W 54.5 - Dpt 26	154
SUMMER end bookshelves W 53.9 - Dpt 21	155
TWIG wardrobes Ht 184.2 - Dpt 56.3	156
TWIG wardrobes Ht 216.2 - Dpt 56.3	158
Accessories for TWIG wardrobe Dpt 56.3	160
Service furniture Dpt 72.3 - technical information	162
Service furniture Dpt 72.3	164
Accessories for service furniture Dpt 72.3	166

# Wardrobes - technical information

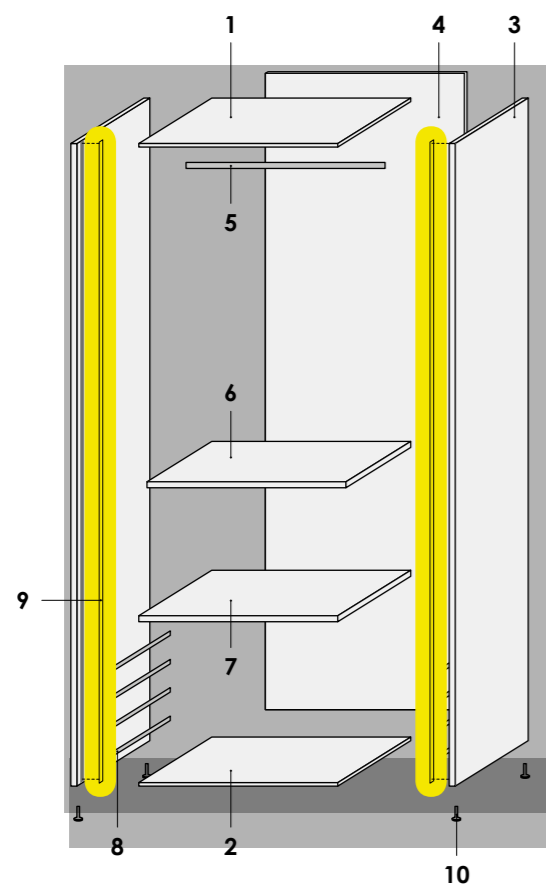

## Components:

- 1 **Top panel Th 1.8** - With eccentric pin system
- 2 **Bottom panel Th 1.8** - With eccentric pin system
- 3 **Side panels Th 1.8** - With prefitted hardware.
- 4 **Back panel Th 0.3 or 0.8 (optional)** - Fitting into shaped connection.
- 5 **BASIC clothes hanging bar** in chromed metal or **PLUS clothes hanging bar (optional)** in aluminum.
- 6 **Movable shelf Th 2.5 Dpt 51.5** - On runner.
- 7 **Dividing movable shelf Th 2.5 Dpt 53** - With sliding support.
- 8 **Metal drawer runners**
- 9 **Strip led (optional)** - In full height milled groove.
- 10 **Adjustable middle-support feet**

## Dimensions:

**W** 30 - 45 - 60 - 90 - 120

**Dpt** 56,3

**Ht** 193,6 - 225,6 - 241,6 - 257,6 - 289,6

- These structures can only be placed on the ground.
- The side panels are flush with the top and bottom and have custom holes.
- The hardware is placed in a personalized fashion according to the position of the components.
- Tops are not finished.
- They are equipped with adjustable feet.

## IMPORTANT!

- The doors are fitted with decelerated hinges.
- The drawers and big drawer CLUB (all widths) and the drawers and big drawer W 120 are always fitted with height-adjustable soft-close "Quadro" metal slides with interior CHARM finish.
- **Internal fittings supplied consist in:** 1 clothes hanging bar in line with doors Ht 96 - 112 - 128 - 160 - 192; 2 clothes hanging bars and 1 movable shelf in line with doors Ht 224 - 240 - 256 - 288. Open units will have 1 movable shelf each 32 cm.
- **For custom cuts consult the relevant chapter.** With small depth wardrobes we recommend using sliding clothes rails.
- In mixed compositions, the handles of the WINDOW doors are not aligned (see example).
- In units W 90 with doors W 30 + W 60 the direction is determined by the position of the door W 60 on the ground.
- Upon request, the doors can be supplied without a handle and without handle holes (not on CLUB and WINDOW door).
- The Wardrobes with pairs of CLUB doors are provided with only one handle. In elements with doors W 30 + 60 the handle is placed on the W 60 door. Upon customer's request the CLUB handle can be mounted on both doors.
- In W 90 units, with transparent glass shelves, an excessive load on the shelves could cause the side panels to warp; it is recommended not to overload them or to insert at least one melamine-coated shelf.

Example of combined composition

**NO**

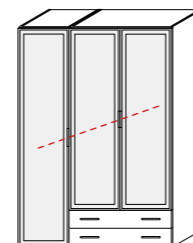

## MODULARITY

- Since this is a container structure each element is complete with 2 side panels; the composition is assembled by fixing the various elements together.
- The fronts are always fit flush, so the side panels are covered by the doors or drawers.
- The overall size of the composition is therefore the sum of the individual fronts.

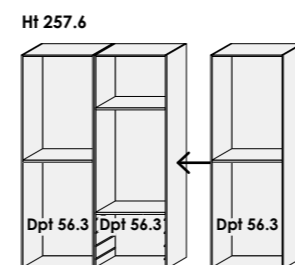

### Example A

Possible combinations of Wardrobes with the same height and depth.

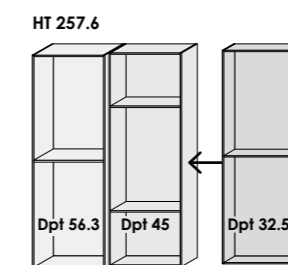

### Example B

Possible combinations of Wardrobes and Container units with the same height and different depths.

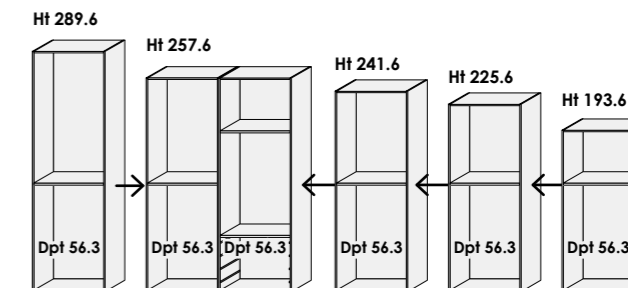

### Example C

Possible combinations of Wardrobes with different heights and the same depth.

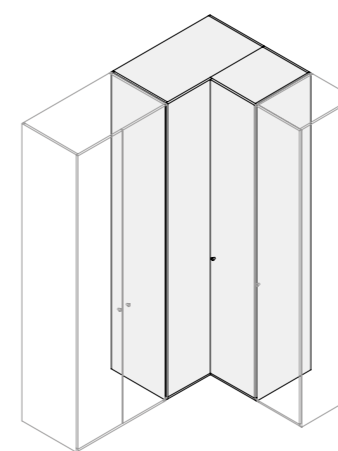
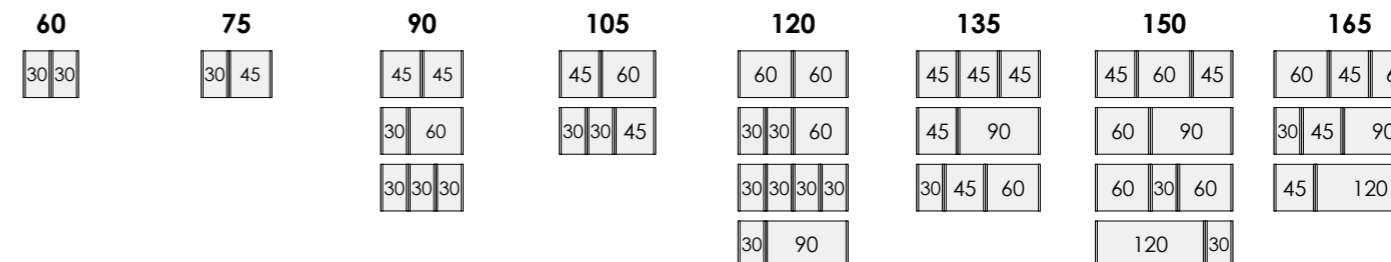

Corner wardrobe unit

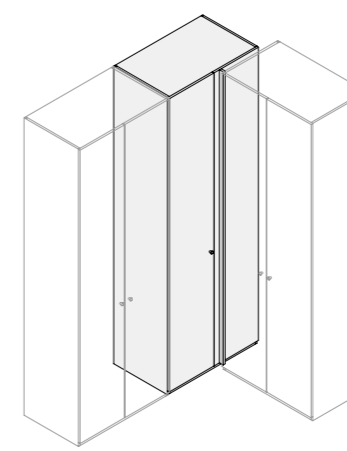

Corner wardrobe

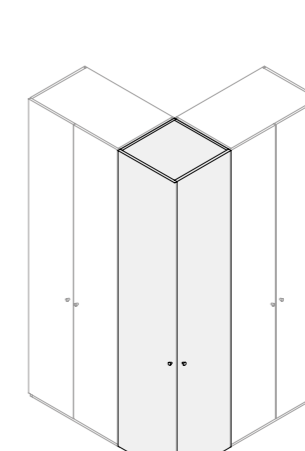

External corner wardrobe

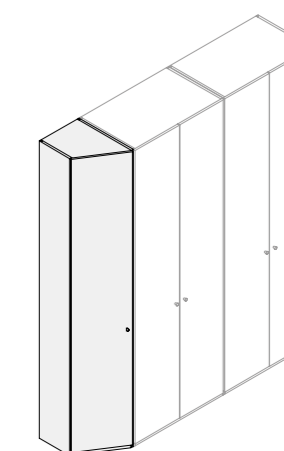

End unit

For technical details see the relevant chapters.



# OPTIONAL for wardrobes

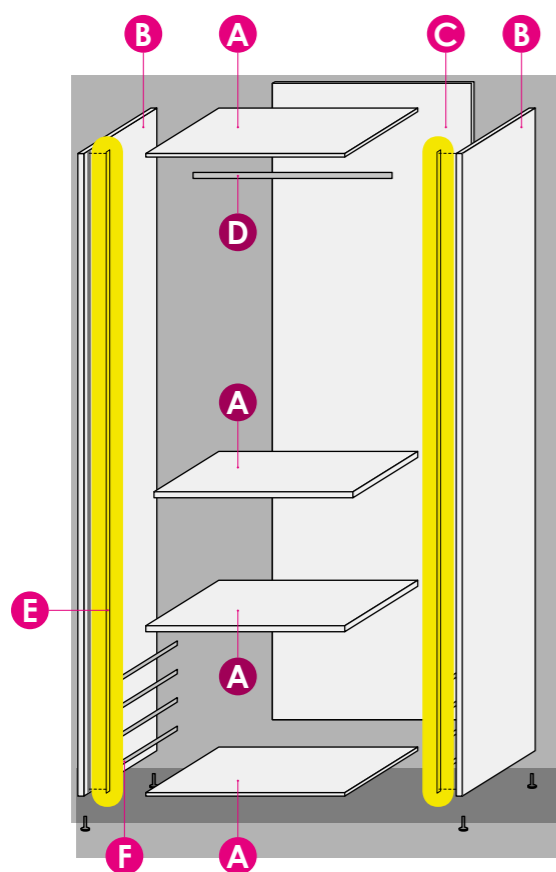

## A Extra colors for Top panel, Bottom panel and Shelves

In addition to the standard CARCASE colors, these components are all available in the GROUP 2 colors with surcharge (see table).

- **When placing the order:** indicate the colour in the HORIZONTAL FINISHES variant in Metron 4: all top panels, bottom panels and shelves will automatically be delivered in that colour (if specified, the various elements can be coloured as preferred).
- **N.B.** The surcharge is applied to each single component.

Top panel Bottom panel Shelves	Surcharge for single element (CARCASE colors excluded)
	Dpt 56,3 - 72,3*
W 30	
W 45	
W 60	
W 90	
W 120	
Corner wardrobe units	
End units	
LOGIK end bookshelf	
QUID end bookshelf	

\* Depth service furniture

## B Extra colors for Side panels

In addition to the standard CARCASE colors, the side panels are available in all the GROUP 2 colors with surcharge (see table).

- **When placing the order:** indicate the colour in the COLOURED FINISHES variant in Metron 4: all side panels will automatically be delivered in that colour (if specified, 1, 2 or more side panels can be coloured as preferred).
- **N.B.** The surcharge is applied to each single side panel except for the END ELEMENTS, for which the choice of colour and surcharge refers to both side panels of the element.

Side panel	Surcharge for single element (CARCASE colors excluded)
	Dpt 56,3 - 72,3*
Ht 193,6	
Ht 225,6	
Ht 241,6	
Ht 257,6	
Ht 289,6	
Wardrobe for passage side panels	Ht 48 Ht 80
Pair of side panels for End units	Ht 193,6
	Ht 225,6
	Ht 241,6
	Ht 257,6
TWIG wardrobe side panels	Ht 184,2 Ht 216,2

\* Depth service furniture

## C Increased Back panel Th 0.8

On request the Wardrobe can be equipped with back panel Th 0.8 with surcharge (see table), in replacement of the standard back panel Th 0.3; unlike the standard one (in the CARCASE colors), the increased back panel is available in all GROUP 2 colors.

- **When placing the order:** indicate YES for increased back panel in the BACK PANEL TYPE variant and the colour in the BACK PANEL COLOUR variant in Metron 4: all back panels will automatically be supplied in the same type and colour (if specified, it is possible to change the back panel type and colour of the various elements as preferred).
- **N.B.** The surcharge is applied to each back panel.

Back panel Th 0.8	Surcharge for single element	
	Ht 193,6 - 225,6 - 241,6 - 257,6	Ht 289,6
W 30		
W 40*		
W 45		
W 60		
W 90		
W 120		
Corner wardrobe units		

\* Back panel for End units

## D PLUS clothes-hanging bar

On request the wardrobe can be equipped with PLUS clothes-hanging bars with surcharge (see table). The PLUS clothes-hanging bar is in aluminium Ø 2.8, available in the Alluminio (AL1A) and Grigio titanio (GZ8T) colors.

- **When placing the order:** indicate PLUS clothes-hanging bar in the BAR TYPE variant and the colour in the BAR COLOUR variant in Metron 4: all bars will automatically be delivered in the same type and same colour.



Clothes-hanging bar	Surcharge for single element
W 30	
W 45	
W 60	
W 90	
W 120	
Corner wardrobe units	

## E Side panels with led lighting

On request the side panels can be equipped with led lighting, with surcharge (see table). Lighting consists in a full-height led strip inset into the side panel.

- **When placing the order:** indicate LIGHT RH SIDE, LIGHT LH SIDE or LIGHT ON BOTH SIDES in the SIDE PANEL LIGHTING variant in Metron 4.
- **N.B.** In whole Corners the lighting will always be on both side panels. In End elements the lighting can only be inserted on the side panel Dpt 54.5.



Led side panel	Surcharge			
	1 side panel	2 side panels	1 side panel	2 side panels
	1 led strip + 1 sensor + 1 power supply	2 led strips + 1 sensor + 1 power supply	1 led strip + 2 sensors + 1 power supply	2 led strips + 2 sensors + 1 power supply
Ht 193,6				
Ht 225,6				
Ht 241,6				
Ht 257,6				
Ht 289,6				

\* For wardrobes with divided doors

## F Drawers and big drawers with soft-close

On request drawers and big drawers in the "standard" version can be equipped with soft-close mechanisms, with surcharge (see table). Alternatively, drawers and big drawers can be ordered in the CHARM version, with surcharge (see table), equipped with soft-close height-adjustable "Quadro" type runners with prestigious internal finish.

- **When placing the order:** indicate the type of runners in the RUNNER TYPE variant in Metron 4.
- **N.B.** The W 120 drawers and big drawers, and CLUB drawers and big drawers (all widths) with soft-close "Quadro" type runners are supplied standard in the CHARM version (without surcharge).

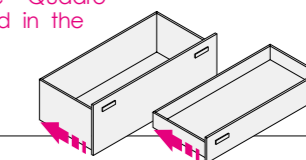

Slow closing	Surcharge for single element
Drawers W 45 - 60 - 90	
Big drawers W 45 - 60 - 90	
CHARM Drawers/Big drawers with "Quadro" type runners W 45 - 60 - 90	

# Made-to-measure solutions for hinged doors

## 🕒 Pitched roof cut

Minimum finished door slant 50°

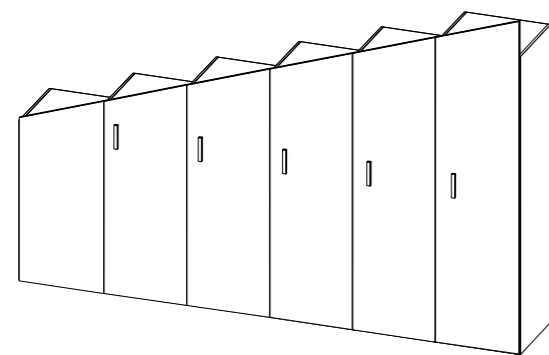

Pitched roof cut on all elements.

FRONT VIEW  
Example 1:

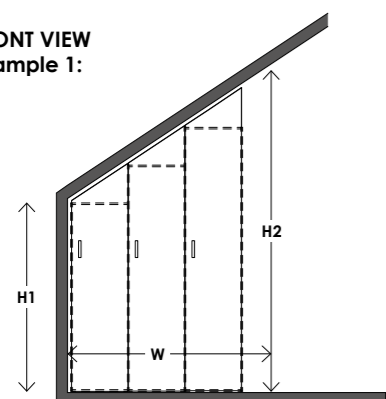

When ordering, you must:

- Place single wardrobes (W 30/45/60) side by side for the desired length.
- Indicate the height of the LH wall (H1).
- Indicate the length (W) and the height of RH wall (H2).

Pitched roof cuts are made to measure only if requested with a detailed drawing.

POSSIBLE CUTS:

- Single wardrobe carcasses (W 30/45/60)
- ONE door at full-height

656 mm : Minimum wardrobe structure height  
2576 mm: Maximum wardrobe structure height  
2556 mm: Maximum door height with oblique cut

Pitched roof cut flanked by linear wardrobe.

FRONT VIEW  
Example 2:

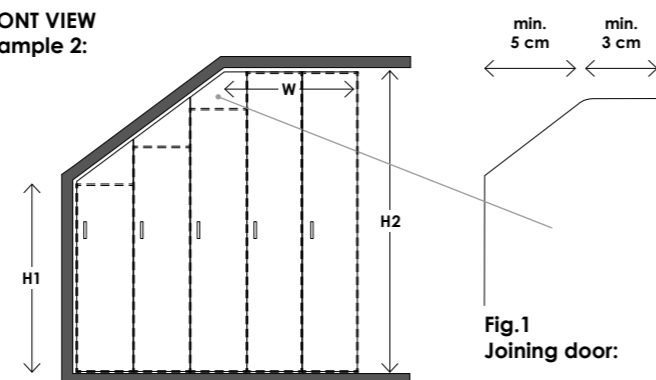

When ordering, you must:

- Place single wardrobes (W 30/45/60) side by side for the desired length.
- Indicate the height of the LH wall (H1).
- Indicate the height of the RH wall (H2).
- Indicate the length (W) of the linear part.

N.B. A joining door will be created which will be aligned with the doors of the straight wardrobe (Fig.1).

## 🕒 Door protruding in height



SIDE VIEW  
Example 1:

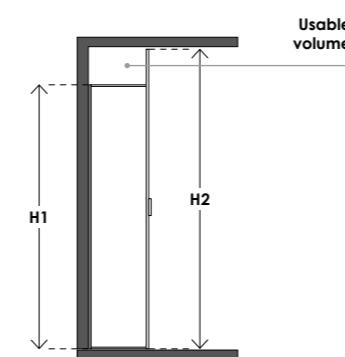

When ordering, you must:

- Place the wardrobes side by side for the desired length.
- Indicate the height of the wardrobe carcass (H1).
- Indicate the height of the door (H2).

Compositions can be created with protruding doors only if requested with detailed drawing.

POSSIBLE CUTS:

- ONE door at full height

656 mm : Minimum wardrobe structure height  
2576 mm: Maximum wardrobe structure height  
2556 mm: Maximum protruding door height

SIDE VIEW  
Example 2:

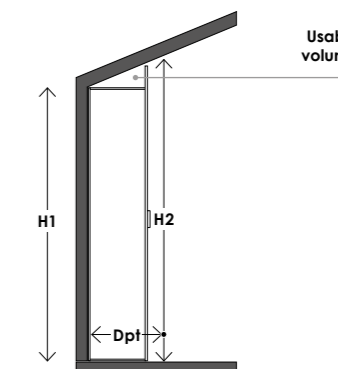

When ordering, you must:

- Place the wardrobes side by side for the desired length.
- Indicate the minimum height of the wall (H1).
- Indicate the depth (Dpt) and the maximum height of the wall (H2).

### CAUTIONS:

- The wardrobe must consist of standard elements W 30/45/60 with full-height door; it is possible to reduce the height and width with the relative rules in the price list in the "Custom cuts" chapter.
- The hinges must always be positioned on the highest side of the door.
- Doors, which are lower by 110 cm, on the handle side, will be supplied with push pull opening.
- A 3 cm technical tolerance is always allowed between the diagonal of the ceiling and the diagonal of the door cut.

### CAUTIONS:

- The wardrobe must be composed of elements with standard structures, possibly reduced in height, width and depth with the relevant rules in the price list in the "Custom cuts" chapter.
- The doors can protrude a max. of 32 cm compared to the carcass.
- Doors, which are lower by 110 cm, will be supplied with push pull opening.
- In the case of a sloping ceiling (see example 2), a technical tolerance of 3 cm between the ceiling and the protruding door is always considered.

## Corner for wardrobe joins with pitched roof cut and protruding doors

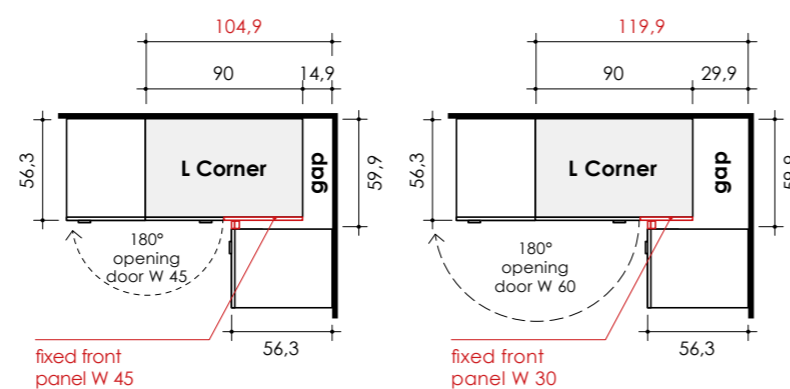
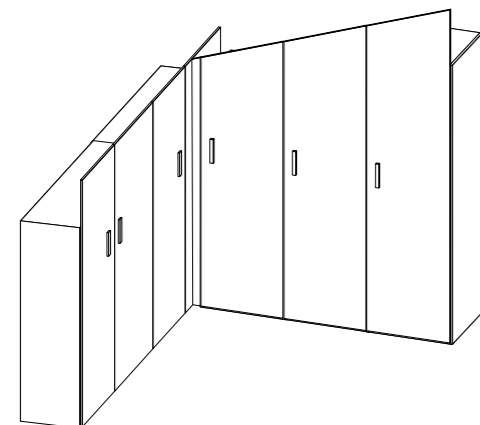

Corner elements to be used to obtain the composition on the side

L in drawings

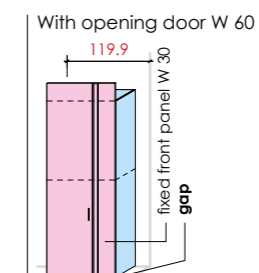
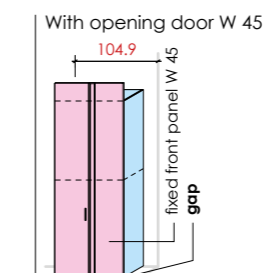

Ht 193.6

Code	L	PK11.51Y	PK11.61D
	R	PK11.56F	PK11.65E

Ht 225.6

Code	L	PK13.51G	PK13.61N
	R	PK13.56Q	PK13.65P

Ht 257.6

Code	L	PK17.51Z	PK17.61E
	R	PK17.56G	PK17.65F

📦 Components in GROUP 2 colors

📦 Components in Types and colors FRONT

🕒 Delivery approximately 4 weeks from order receipt.

# Wardrobes Ht 193.6 - Dpt 56.3



Wardrobes hinged doors

## W 30

Specify hinge R or L

Reference images →

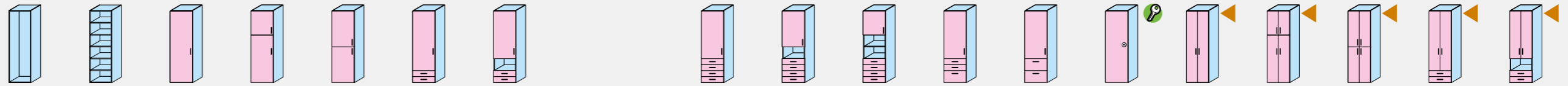

Code	PK10.01S	PK10.02Y	PK10.03E	PK10.04M	PK10.05T	-	-	-	-	-	-	-	-	-	-	-	-	-	-	
ONE	matte																			
	glossy																			
CLUB																				
WINDOW																				

## W 45

Specify hinge R or L

Code	PK10.06Z	PK10.07F	PK10.08N	PK10.09U	PK10.10R	PK10.11X	PK10.12D	-	PK10.13L	PK10.14S	PK10.15Y	PK10.16E	PK10.17M	PK10.18T	-	-	-	-	-	
ONE	matte																			
	glossy																			
CLUB																				
WINDOW																				

## W 60

Specify hinge R or L

Code	PK10.19Z	PK10.20W	PK10.21C	PK10.22K	PK10.23R	PK10.24X	PK10.25D	-	PK10.26L	PK10.27S	PK10.28Y	PK10.29E	PK10.30B	PK10.31H	PK10.32Q	PK10.33W	PK10.34C	PK10.35K	PK10.36R	
ONE	matte																			
	glossy																			
CLUB																				
WINDOW																				

## W 90

Reference images →

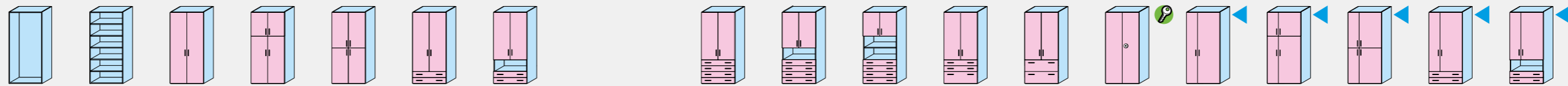

Code	PK10.40G	PK10.41P	PK10.42V	PK10.43B	PK10.44H	PK10.45Q	PK10.46W	-	PK10.47C	PK10.48K	PK10.49R	PK10.50N	PK10.51U	PK10.52A	PK10.53G	PK10.54P	PK10.55V	PK10.56B	PK10.57H	
ONE	matte																			
	glossy																			
CLUB																				
WINDOW																				

## W 120

Drawers and big drawers CHARM with "Quadro" soft rails as standard (without surcharges)

Code	PK10.62F	PK10.63N	PK10.64U	PK10.65A	PK10.66G	PK10.67P	PK10.68V	-	PK10.69B	PK10.70Y	PK10.71E	PK10.72M	PK10.73T	PK10.74Z	-	-	-	-	-	
ONE	matte																			
	glossy																			
CLUB																				
WINDOW																				

- Components in **GROUP 2 colors**
- Components in **Types and colors FRONT**

- ▼ With doors **W 30**
- ▼ With doors **W 30 + W 60** - Indicate R or L (drawing - R)
- 🔒 Element complete with bar lock.

**CLUB**

drawers and big drawers CHARM with soft-close "Quadro" type slides as standard (without surcharges)

# Wardrobes Ht 193.6 - Dpt 56.3

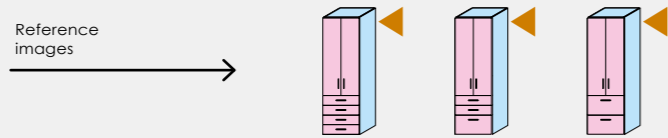

## W 30

Specify hinge  
R or L

Code	-	-	-																
ONE	matte	-	-	-															
	glossy	-	-	-															
CLUB		-	-	-															
WINDOW		-	-	-															

## W 45

Specify hinge  
R or L

Code	-	-	-																
ONE	matte	-	-	-															
	glossy	-	-	-															
CLUB		-	-	-															
WINDOW		-	-	-															

## W 60

Specify hinge  
R or L

Code	PK10.37X	PK10.38D	PK10.39L																
ONE	matte																		
	glossy																		
CLUB																			
WINDOW																			

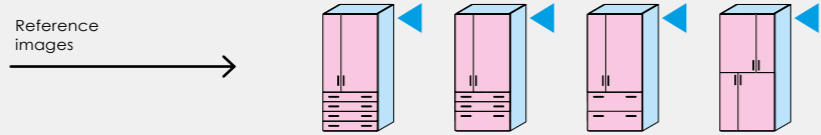

## W 90

Code	PK10.58Q	PK10.59W	PK10.60T	PK10.61Z															
ONE	matte																		
	glossy																		
CLUB																			
WINDOW																			

## W 120

Drawers and big drawers  
CHARM with "Quadro" soft  
rails as standard  
(without surcharges)

Code	-	-	-	-															
ONE	matte	-	-	-	-														
	glossy	-	-	-	-														
CLUB		-	-	-	-														
WINDOW		-	-	-	-														

- Components in **GROUP 2 colors**
- Components in **Types and colors FRONT**

- ▼ With doors W 30
- ▼ With doors W 30 + W 60 - Indicate R or L (drawing - R)

**CLUB**

drawers and big drawers  
CHARM with soft-close "Quadro"  
type slides as standard  
(without surcharges)

# Wardrobes Ht 193.6 - Dpt 56.3 - with niche

All wardrobes are equipped with increased back panel Th 0.8

## W 30

Specify hinge  
R or L

Reference  
images →

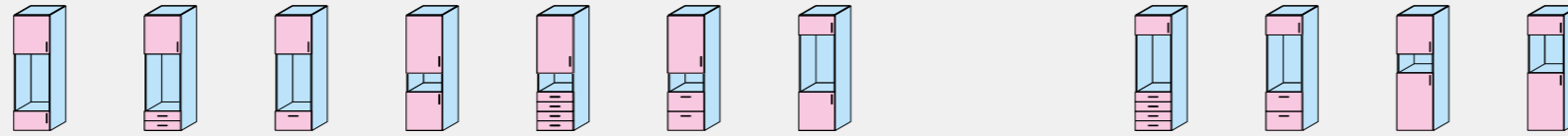

Code	PK06.00H	-	-	PK06.01Q	-	-	PK06.02W	-	-	PK06.31F	PK06.32N						
ONE	matte																
	glossy																
CLUB																	
WINDOW																	

## W 45

Specify hinge  
R or L

Code	PK06.03C	PK06.04K	PK06.05R	PK06.06X	PK06.07D	PK06.08L	PK06.09S		PK06.33U	PK06.34A	PK06.35G	PK06.36P					
ONE	matte																
	glossy																
CLUB																	
WINDOW																	

## W 60

Specify hinge  
R or L

Code	PK06.10P	PK06.11V	PK06.12B	PK06.13H	PK06.14Q	PK06.15W	PK06.16C		PK06.37V	PK06.38B	PK06.39H	PK06.40E					
ONE	matte																
	glossy																
CLUB																	
WINDOW																	

## W 90

Reference  
images →

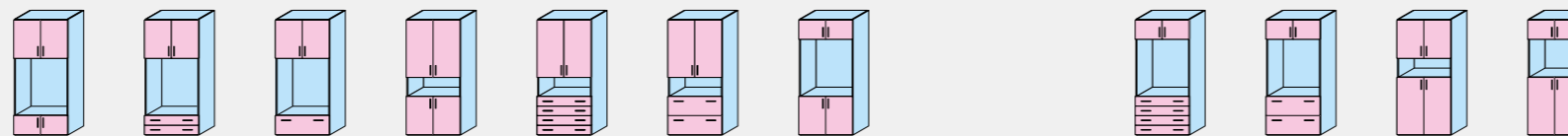

Code	PK06.17K	PK06.18R	PK06.19X	PK06.20U	PK06.21A	PK06.22G	PK06.23P		PK06.41M	PK06.42T	PK06.43Z	PK06.44F					
ONE	matte																
	glossy																
CLUB																	
WINDOW																	

## W 120

Drawers and big drawers  
CHARM with "Quadro" soft  
rails as standard  
(without surcharges)

Code	PK06.24V	PK06.25B	PK06.26H	PK06.27Q	PK06.28W	PK06.29C	PK06.30Z		PK06.45N	PK06.46U	PK06.47A	PK06.48G					
ONE	matte																
	glossy																
CLUB																	
WINDOW																	

■ Components in **GROUP 2 colors**  
■ Components in **Types and colors FRONT**  
■ FABRIC JENNY 0402 0403 0503 0900 0903 0905 0314 0303 0805 0706 0704 0601 0604  
■ FABRIC KENYA 0014 0013 0016 0020 0019

**Cushion Th 6**  
To be used inside the niches.  
Removable covers.

W	Code
86	PK01.96Z
116	PK01.97F

**p. 44** Filler strips  
**p. 56** Knob and handle positions  
**p. 132** Accessories for Wardrobe Dpt 56.3

**CLUB**  
drawers and big drawers  
CHARM with soft-close "Quadro"  
type slides as standard  
(without surcharges)



# Wardrobes Ht 225.6 - Dpt 56.3



Wardrobes  
hinged doors

## W 30

Specify hinge  
R or L

Reference  
images →

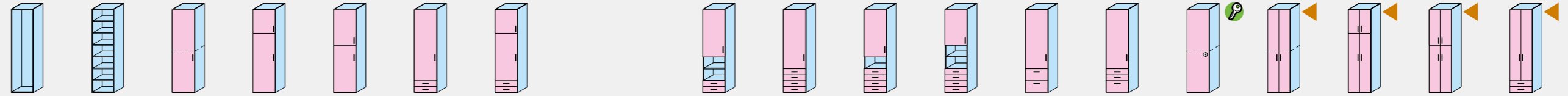

Code	PK12.01A	PK12.02G	PK12.03P	PK12.04V	PK12.05B	-	-	-	-	-	-	-	-	-	-	-	-	-	-	
ONE	matte																			
	glossy																			
CLUB																				
WINDOW																				

## W 45

Specify hinge  
R or L

Code	PK12.06H	PK12.07Q	PK12.08W	PK12.09C	PK12.10Z	PK12.11F	PK12.12N	-	PK12.13U	PK12.14A	PK12.15G	PK12.16P	PK12.17V	PK12.18B	PK12.19H	-	-	-	-	
ONE	matte																			
	glossy																			
CLUB																				
WINDOW																				

## W 60

Specify hinge  
R or L

Code	PK12.20E	PK12.21M	PK12.22T	PK12.23Z	PK12.24F	PK12.25N	PK12.26U	-	PK12.27A	PK12.28G	PK12.29P	PK12.30L	PK12.31S	PK12.32Y	PK12.33E	PK12.34M	PK12.35T	PK12.36Z	PK12.37F	
ONE	matte																			
	glossy																			
CLUB																				
WINDOW																				

## W 90

Reference  
images →

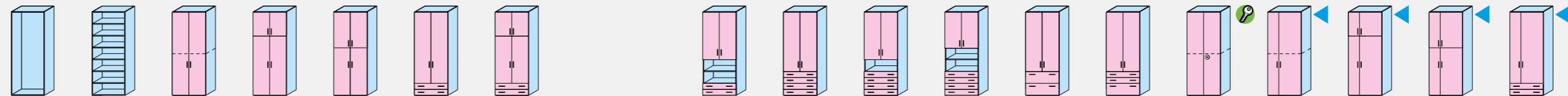

Code	PK12.43L	PK12.44S	PK12.45Y	PK12.46E	PK12.47M	PK12.48T	PK12.49Z	-	PK12.50W	PK12.51C	PK12.52K	PK12.53R	PK12.54X	PK12.55D	PK12.56L	PK12.57S	PK12.58Y	PK12.59E	PK12.60B
ONE	matte																		
	glossy																		
CLUB																			
WINDOW																			

## W 120

Drawers and big drawers  
CHARM with "Quadro" soft  
rails as standard  
(without surcharges)

Code	PK12.67X	PK12.68D	PK12.69L	PK12.70G	PK12.71P	PK12.72V	PK12.73B	-	PK12.74H	PK12.75Q	PK12.76W	PK12.77C	PK12.78K	PK12.79R	PK12.80N	-	-	-	-
ONE	matte																		
	glossy																		
CLUB																			
WINDOW																			

- Components in **GROUP 2 colors**
- Components in **Types and colors FRONT**

- ▼ With doors **W 30**
- ▼ With doors **W 30 + W 60** - Indicate R or L (drawing - R)
- 🔒 Element complete with bar lock.

**CLUB**

drawers and big drawers  
CHARM with soft-close "Quadro"  
type slides as standard  
(without surcharges)

# Wardrobes Ht 225.6 - Dpt 56.3

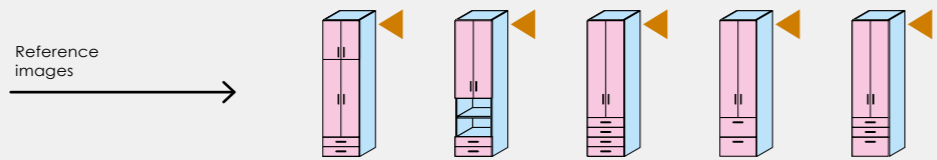

## W 30

Specify hinge  
R or L

Code	-	-	-	-	-														
ONE	matte	-	-	-	-														
	glossy	-	-	-	-														
CLUB		-	-	-	-														
WINDOW		-	-	-	-														

## W 45

Specify hinge  
R or L

Code	-	-	-	-	-														
ONE	matte	-	-	-	-														
	glossy	-	-	-	-														
CLUB		-	-	-	-														
WINDOW		-	-	-	-														

## W 60

Specify hinge  
R or L

Code		PK12.38N	PK12.39U	PK12.40R	PK12.41X	PK12.42D													
ONE	matte																		
	glossy																		
CLUB																			
WINDOW																			

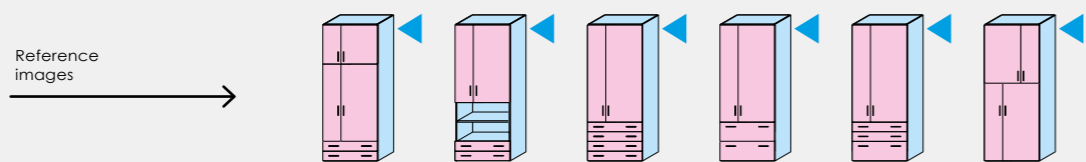

## W 90

Code		PK12.61H	PK12.62Q	PK12.63W	PK12.64C	PK12.65K	PK12.66R												
ONE	matte																		
	glossy																		
CLUB																			
WINDOW																			

## W 120

Drawers and big drawers  
CHARM with "Quadro" soft  
rails as standard  
(without surcharges)

Code	-	-	-	-	-	-													
ONE	matte	-	-	-	-	-													
	glossy	-	-	-	-	-													
CLUB		-	-	-	-	-													
WINDOW		-	-	-	-	-													

- Components in **GROUP 2 colors**
- Components in **Types and colors FRONT**

- ▼ With doors W 30
- ▼ With doors W 30 + W 60 - Indicate R or L (drawing - R)

**CLUB**

drawers and big drawers  
CHARM with soft-close "Quadro"  
type slides as standard  
(without surcharges)

# Wardrobes Ht 225.6 - Dpt 56.3 - with niche

All wardrobes are equipped with increased back panel Th 0.8

Reference images →

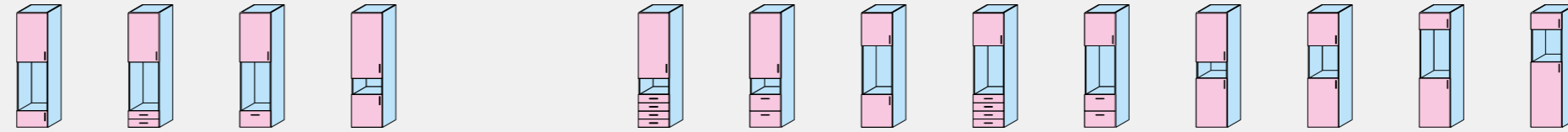

## W 30

Specify hinge R or L

Code																				
ONE	matte																			
	glossy																			
CLUB																				
WINDOW																				

## W 45

Specify hinge R or L

Code																				
ONE	matte																			
	glossy																			
CLUB																				
WINDOW																				

## W 60

Specify hinge R or L

Code																				
ONE	matte																			
	glossy																			
CLUB																				
WINDOW																				

Reference images →

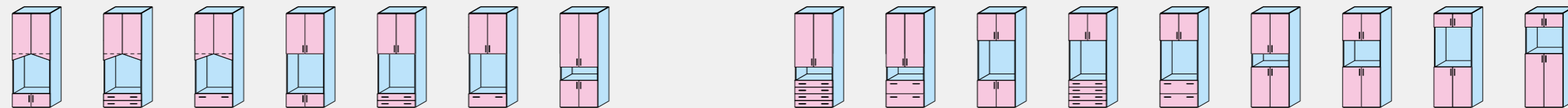

## W 90

Code																				
ONE	matte																			
	glossy																			
CLUB																				
WINDOW																				

## W 120

Drawers and big drawers CHARM with "Quadro" soft rails as standard (without surcharges)

Code																				
ONE	matte																			
	glossy																			
CLUB																				
WINDOW																				

Components in **GROUP 2 colors**

Components in **Types and colors FRONT**

FABRIC JENNY: 0402, 0403, 0503, 0900, 0903, 0905, 0314, 0303, 0805, 0706, 0704, 0601, 0604

FABRIC KENYA: 0014, 0013, 0016, 0020, 0019

**Cushion Th 6**

To be used inside the niches. Removable covers.

**Dpt 53**

Code

86: PK01.96Z

116: PK01.97F

**CLUB**

drawers and big drawers CHARM with soft-close "Quadro" type slides as standard (without surcharges)

p. 44 Filler strips  
 p. 56 Knob and handle positions  
 p. 132 Accessories for Wardrobe Dpt 56.3

Wardrobes hinged doors

# Wardrobes Ht 241.6 - Dpt 56.3



Wardrobes  
hinged doors

Reference images →

Code	PK14.01K	PK14.02R	PK14.03X	PK14.04D	PK14.05L	PK14.06S	PK14.07Y		-	-	-	-	-	-	-	-	-	-	-	
ONE	matte																			
ONE	glossy																			
CLUB																				
WINDOW																				

## W 30

Specify hinge  
R or L

## W 45

Specify hinge  
R or L

Code	PK14.08E	PK14.09M	PK14.10H	PK14.11Q	PK14.12W	PK14.13C	PK14.14K		PK14.15R	PK14.16X	PK14.17D	PK14.18L	PK14.19S	PK14.20P	PK14.21V	PK14.22B	PK14.23H	PK14.24Q	PK14.25W	
ONE	matte																			
ONE	glossy																			
CLUB																				
WINDOW																				

## W 60

Specify hinge  
R or L

Code	PK14.27K	PK14.28R	PK14.29X	PK14.30U	PK14.31A	PK14.32G	PK14.33P		PK14.34V	PK14.35B	PK14.36H	PK14.37Q	PK14.38W	PK14.39C	PK14.40Z	PK14.41F	PK14.42N	PK14.43U	PK14.44A	
ONE	matte																			
ONE	glossy																			
CLUB																				
WINDOW																				

Reference images →

Code	PK14.57A	PK14.58G	PK14.59P	PK14.60L	PK14.61S	PK14.62Y	PK14.63E		PK14.64M	PK14.65T	PK14.66Z	PK14.67F	PK14.68N	PK14.69U	PK14.70R	PK14.71X	PK14.72D	PK14.73L	PK14.74S	
ONE	matte	248,00																		
ONE	glossy	-																		
CLUB																				
WINDOW																				

## W 90

## W 120

Drawers and big drawers  
CHARM with "Quadro" soft  
rails as standard  
(without surcharges)

Code	PK14.89E	PK14.90B	PK14.91H	PK14.92Q	PK14.93W	PK14.94C	PK14.95K		PK14.96R	PK14.97X	PK14.98D	PK14.99L	PK15.00G	PK15.01P	PK15.02V	PK15.03B	PK15.04H	PK15.05Q	PK15.06W
ONE	matte																		
ONE	glossy																		
CLUB																			
WINDOW																			

- Components in **GROUP 2 colors**
- Components in **Types and colors FRONT**

**CLUB**  
drawers and big drawers  
CHARM with soft-close "Quadro"  
type slides as standard  
(without surcharges)



p. 44 Filler strips  
p. 56 Knob and handle positions  
p. 132 Accessories for Wardrobe Dpt 56.3

# Wardrobes Ht 241.6 - Dpt 56.3

## W 30

Specify hinge  
R or L

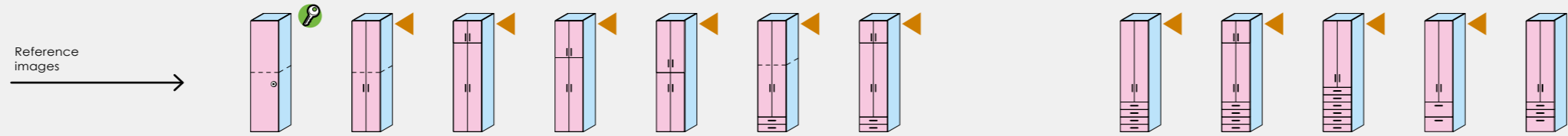

Code	-	-	-	-	-	-	-	-	-	-	-	-	-	-	-	-	-	-
ONE	matte	-	-	-	-	-	-	-	-	-	-	-	-	-	-	-	-	-
	glossy	-	-	-	-	-	-	-	-	-	-	-	-	-	-	-	-	-
CLUB		-	-	-	-	-	-	-	-	-	-	-	-	-	-	-	-	-
WINDOW		-	-	-	-	-	-	-	-	-	-	-	-	-	-	-	-	-

## W 45

Specify hinge  
R or L

Code	PK14.26C	-	-	-	-	-	-	-	-	-	-	-	-	-	-	-	-	-
ONE	matte			-	-	-	-	-	-	-	-	-	-	-	-	-	-	-
	glossy			-	-	-	-	-	-	-	-	-	-	-	-	-	-	-
CLUB				-	-	-	-	-	-	-	-	-	-	-	-	-	-	-
WINDOW				-	-	-	-	-	-	-	-	-	-	-	-	-	-	-

## W 60

Specify hinge  
R or L

Code	PK14.45G	PK14.46P	PK14.47V	PK14.48B	PK14.49H	PK14.50E	PK14.51M		PK14.52T	PK14.53Z	PK14.54F	PK14.55N	PK14.56U					
ONE	matte																	
	glossy																	
CLUB																		
WINDOW																		

## W 90

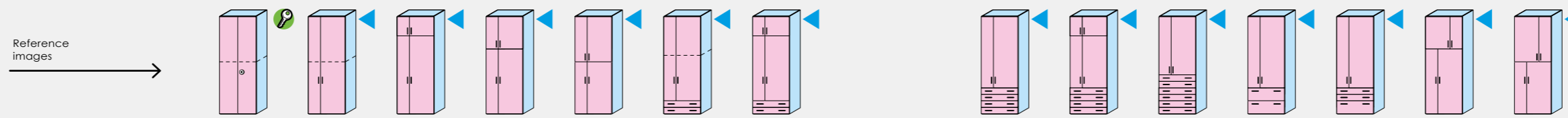

Code	PK14.75Y	PK14.76E	PK14.77M	PK14.78T	PK14.79Z	PK14.80W	PK14.81C		PK14.82K	PK14.83R	PK14.84X	PK14.85D	PK14.86L	PK14.87S	PK14.88Y			
ONE	matte																	
	glossy																	
CLUB																		
WINDOW																		

## W 120

Drawers and big drawers  
CHARM with "Quadro" soft  
rails as standard  
(without surcharges)

Code	PK15.07C	-	-	-	-	-	-	-	-	-	-	-	-	-	-	-	-	-
ONE	matte			-	-	-	-	-	-	-	-	-	-	-	-	-	-	-
	glossy			-	-	-	-	-	-	-	-	-	-	-	-	-	-	-
CLUB				-	-	-	-	-	-	-	-	-	-	-	-	-	-	-
WINDOW				-	-	-	-	-	-	-	-	-	-	-	-	-	-	-

- Components in **GROUP 2 colors**
- Components in **Types and colors FRONT**

- ▼ With doors **W 30**
- ▼ With doors **W 30 + W 60** - Indicate R or L (drawing - R)
- 🔒 Element complete with bar lock.



- OPTIONAL:**  
p. 86
- A** · Extra colors for Top panel, Bottom panel and Shelves
  - B** · Extra colors for Side panels
  - C** · Increased Back panel Th 0.8
  - D** · PLUS clothes-hanging bar
  - E** · Side panels with led lighting
  - F** · Drawers and big drawers with soft-close

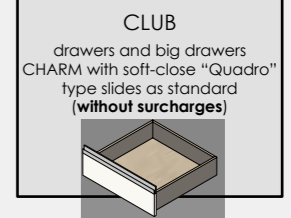

- p. 44 Filler strips
- p. 56 Knob and handle positions
- p. 132 Accessories for Wardrobe Dpt 56.3



# Wardrobes Ht 241.6 - Dpt 56.3 - with niche

All wardrobes are equipped with increased back panel Th 0.8

## W 30

Specify hinge R or L

Reference images →



Code	PK09.00W	-	-	PK09.01C	-	-	PK09.24H	-	-	PK09.25Q	PK09.26W	PK09.27C	PK09.28K					
ONE	matte																	
	glossy																	
CLUB																		
WINDOW																		

## W 45

Specify hinge R or L

Code	PK09.02K	PK09.03R	PK09.04X	PK09.05D	PK09.29R	PK09.30N	PK09.31U		PK09.32A	PK09.33G	PK09.34P	PK09.35V	PK09.36B	PK09.37H					
ONE	matte																		
	glossy																		
CLUB																			
WINDOW																			

## W 60

Specify hinge R or L

Code	PK09.06L	PK09.07S	PK09.08Y	PK09.09E	PK09.38Q	PK09.39W	PK09.40T		PK09.41Z	PK09.42F	PK09.43N	PK09.44U	PK09.45A	PK09.46G					
ONE	matte																		
	glossy																		
CLUB																			
WINDOW																			

## W 90

Reference images →

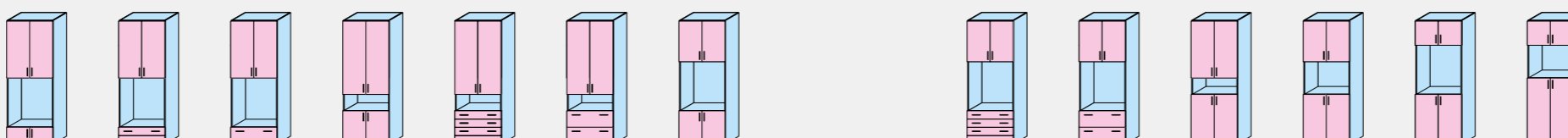

Code	PK09.13W	PK09.14C	PK09.15K	PK09.16R	PK09.47P	PK09.48V	PK09.49B		PK09.50Y	PK09.51E	PK09.52M	PK09.53T	PK09.54Z	PK09.55F					
ONE	matte																		
	glossy																		
CLUB																			
WINDOW																			

## W 120

Drawers and big drawers CHARM with "Quadro" soft rails as standard (without surcharges)

Code	PK09.20G	PK09.21P	PK09.22V	PK09.23B	PK09.56N	PK09.57U	PK09.58A		PK09.59G	PK09.60D	PK09.61L	PK09.62S	PK09.63Y	PK09.64E					
ONE	matte																		
	glossy																		
CLUB																			
WINDOW																			

Components in **GROUP 2 colors**

Components in **Types and colors FRONT**

FABRIC JENNY: 0402, 0403, 0503, 0900, 0903, 0905, 0314, 0303, 0805, 0706, 0704, 0601, 0604

FABRIC KENYA: 0014, 0013, 0016, 0020, 0019

**Cushion Th 6**  
To be used inside the niches. Removable covers.

**Dpt 53**

W	Code
86	PK01.96Z
116	PK01.97F

**OPTIONAL:** p. 86

- A · Extra colors for Top panel, Bottom panel and Shelves
- B · Extra colors for Side panels
- D · PLUS clothes-hanging bar
- E · Side panels with led lighting
- F · Drawers and big drawers with soft-close

p. 44 Filler strips  
p. 56 Knob and handle positions  
p. 132 Accessories for Wardrobe Dpt 56.3

**CLUB**  
drawers and big drawers CHARM with soft-close "Quadro" type slides as standard (without surcharges)

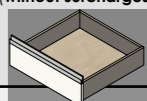

# Wardrobes Ht 257.6 - Dpt 56.3

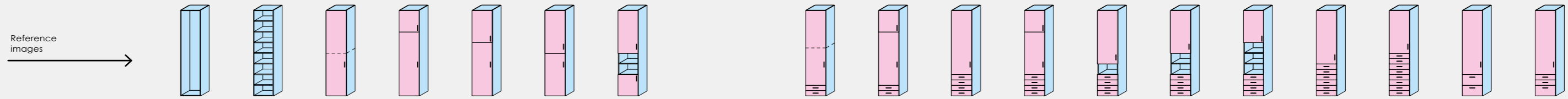

## W 30

Specify hinge  
R or L

Code	PK16.01T	PK16.02Z	PK16.03F	PK16.04N	PK16.05U	PK16.06A	PK16.07G		-	-	-	-	-	-	-	-	-	-	-
ONE	matte																		
	glossy																		
CLUB																			
WINDOW																			

## W 45

Specify hinge  
R or L

Code	PK16.08P	PK16.09V	PK16.10S	PK16.11Y	PK16.12E	PK16.13M	PK16.14T		PK16.15Z	PK16.16F	PK16.17N	PK16.18U	PK16.19A	PK16.20X	PK16.21D	PK16.22L	PK16.23S	PK16.24Y	PK16.25E
ONE	matte																		
	glossy																		
CLUB																			
WINDOW																			

## W 60

Specify hinge  
R or L

Code	PK16.27T	PK16.28Z	PK16.29F	PK16.30C	PK16.31K	PK16.32R	PK16.33X		PK16.34D	PK16.35L	PK16.36S	PK16.37Y	PK16.38E	PK16.39M	PK16.40H	PK16.41Q	PK16.42W	PK16.43C	PK16.44K
ONE	matte																		
	glossy																		
CLUB																			
WINDOW																			

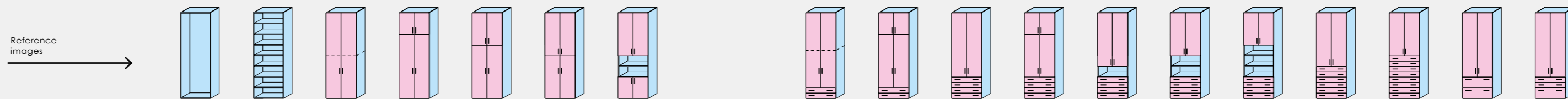

## W 90

Code	PK16.57K	PK16.58R	PK16.59X	PK16.60U	PK16.61A	PK16.62G	PK16.63P		PK16.64V	PK16.65B	PK16.66H	PK16.67Q	PK16.68W	PK16.69C	PK16.70Z	PK16.71F	PK16.72N	PK16.73U	PK16.74A
ONE	matte																		
	glossy																		
CLUB																			
WINDOW																			

## W 120

Drawers and big drawers  
CHARM with "Quadro" soft  
rails as standard  
(without surcharges)

Code	PK16.89P	PK16.90L	PK16.91S	PK16.92Y	PK16.93E	PK16.94M	PK16.95T		PK16.96Z	PK16.97F	PK16.98N	PK16.99U	PK17.00R	PK17.01X	PK17.02D	PK17.03L	PK17.04S	PK17.05Y	PK17.06E
ONE	matte																		
	glossy																		
CLUB																			
WINDOW																			

- Components in **GROUP 2 colors**
- Components in **Types and colors FRONT**



- OPTIONAL:**  
p. 86
- A · Extra colors for Top panel, Bottom panel and Shelves
  - B · Extra colors for Side panels
  - C · Increased Back panel Th 0.8
  - D · PLUS clothes-hanging bar
  - E · Side panels with led lighting
  - F · Drawers and big drawers with soft-close

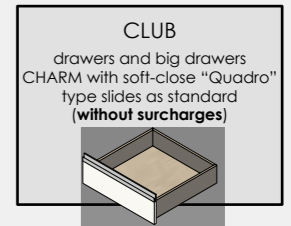

- p. 44 Filler strips
- p. 56 Knob and handle positions
- p. 132 Accessories for Wardrobe Dpt 56.3

# Wardrobes Ht 257.6 - Dpt 56.3

## W 30

Specify hinge  
R or L

Reference  
images →

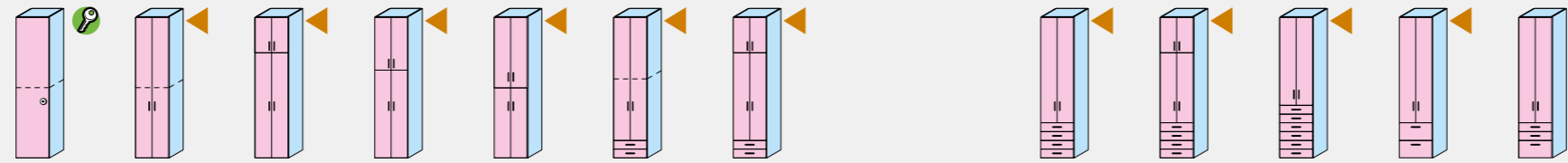

Code	-	-	-	-	-	-	-	-	-	-	-	-	-	-	-	-	-	-
ONE	matte	-	-	-	-	-	-	-	-	-	-	-	-	-	-	-	-	-
	glossy	-	-	-	-	-	-	-	-	-	-	-	-	-	-	-	-	-
CLUB		-	-	-	-	-	-	-	-	-	-	-	-	-	-	-	-	-
WINDOW		-	-	-	-	-	-	-	-	-	-	-	-	-	-	-	-	-

## W 45

Specify hinge  
R or L

Code	PK16.26M	-	-	-	-	-	-	-	-	-	-	-	-	-	-	-	-	-
ONE	matte			-	-	-	-	-	-	-	-	-	-	-	-	-	-	-
	glossy			-	-	-	-	-	-	-	-	-	-	-	-	-	-	-
CLUB				-	-	-	-	-	-	-	-	-	-	-	-	-	-	-
WINDOW				-	-	-	-	-	-	-	-	-	-	-	-	-	-	-

## W 60

Specify hinge  
R or L

Code	PK16.45R	PK16.46X	PK16.47D	PK16.48L	PK16.49S	PK16.50P	PK16.51V		PK16.52B	PK16.53H	PK16.54Q	PK16.55W	PK16.56C					
ONE	matte																	
	glossy																	
CLUB																		
WINDOW																		

## W 90

Reference  
images →

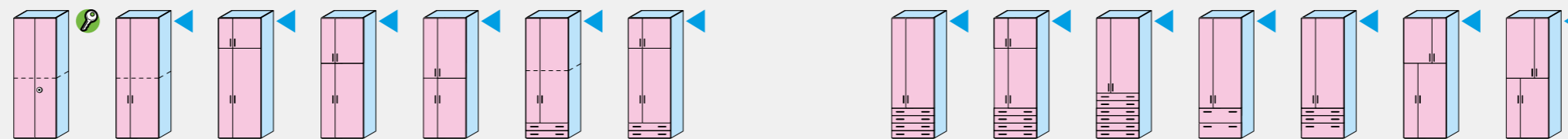

Code	PK16.75G	PK16.76P	PK16.77V	PK16.78B	PK16.79H	PK16.80E	PK16.81M		PK16.82T	PK16.83Z	PK16.84F	PK16.85N	PK16.86U	PK16.87A	PK16.88G			
ONE	matte																	
	glossy																	
CLUB																		
WINDOW																		

## W 120

Drawers and big drawers  
CHARM with "Quadro" soft  
rails as standard  
(without surcharges)

Code	PK17.07M	-	-	-	-	-	-	-	-	-	-	-	-	-	-	-	-	-
ONE	matte																	
	glossy																	
CLUB																		
WINDOW																		

Components in **GROUP 2 colors**  
 Components in **Types and colors FRONT**

With doors **W 30**  
 With doors **W 30 + W 60** - Indicate R or L (drawing - R)  
 Element complete with bar lock.



**OPTIONAL:**  
p. 86

- A · Extra colors for Top panel, Bottom panel and Shelves
- B · Extra colors for Side panels
- C · Increased Back panel Th 0.8
- D · PLUS clothes-hanging bar
- E · Side panels with led lighting
- F · Drawers and big drawers with soft-close

**CLUB**  
drawers and big drawers  
CHARM with soft-close "Quadro"  
type slides as standard  
(without surcharges)



p. 44 Filler strips  
 p. 56 Knob and handle positions  
 p. 132 Accessories for Wardrobe Dpt 56.3

# Wardrobes Ht 257.6 - Dpt 56.3 - with niche

All wardrobes are equipped with increased back panel Th 0.8

Wardrobes hinged doors

## W 30

Specify hinge R or L

Reference images →

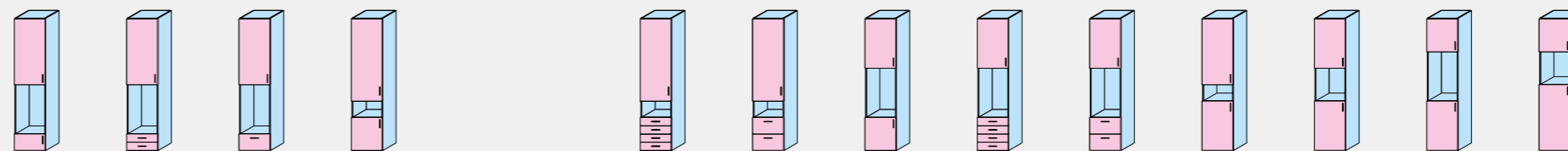

Code					PK08.00S	-	-	PK08.01Y											
ONE	matte																		
	glossy																		
CLUB																			
WINDOW																			

## W 45

Specify hinge R or L

Code					PK08.02E	PK08.03M	PK08.04T	PK08.05Z											
ONE	matte																		
	glossy																		
CLUB																			
WINDOW																			

## W 60

Specify hinge R or L

Code					PK08.06F	PK08.07N	PK08.08U	PK08.09A											
ONE	matte																		
	glossy																		
CLUB																			
WINDOW																			

## W 90

Reference images →

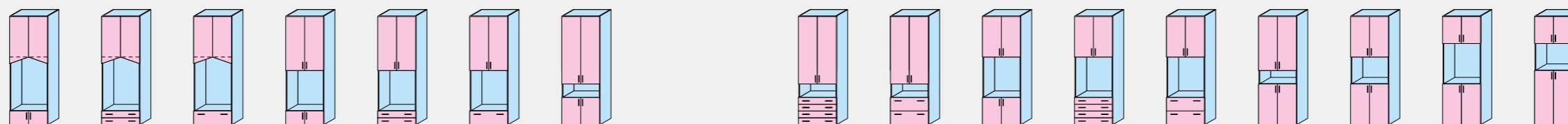

Code																			
ONE	matte	PK08.10X	PK08.11D	PK08.12L	PK08.13S	PK08.14Y	PK08.15E	PK08.16M											
	glossy																		
CLUB																			
WINDOW																			

## W 120

Drawers and big drawers CHARM with "Quadro" soft rails as standard (without surcharges)

Code																			
ONE	matte	PK08.17T	PK08.18Z	PK08.19F	PK08.20C	PK08.21K	PK08.22R	PK08.23X											
	glossy																		
CLUB																			
WINDOW																			

■ Components in **GROUP 2 colors**  
■ Components in **Types and colors FRONT**  
■ FABRIC JENNY  
■ FABRIC KENYA

0402	0403	0503	0900	0903	0905	0314	0303	0805	0706	0704	0601	0604
0014	0013	0016	0020	0019								

**Cushion Th 6**  
To be used inside the niches. Removable covers.

**Dpt 53**



W	Code
86	PK01.96Z
116	PK01.97F

**OPTIONAL:** p. 86

- A · Extra colors for Top panel, Bottom panel and Shelves
- B · Extra colors for Side panels
- D · PLUS clothes-hanging bar
- E · Side panels with led lighting
- F · Drawers and big drawers with soft-close

 p. 44 Filler strips  
 p. 56 Knob and handle positions  
 p. 132 Accessories for Wardrobe Dpt 56.3

**CLUB**  
drawers and big drawers CHARM with soft-close "Quadro" type slides as standard (without surcharges)

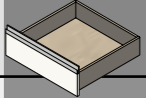

# Wardrobes Ht 289.6 - Dpt 56.3



Reference images →

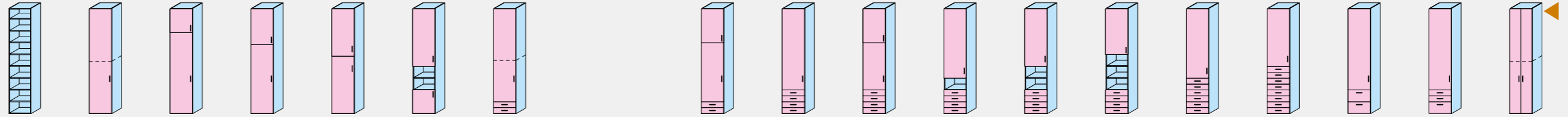

## W 30

Specify hinge R or L

Code	PK18.01B	PK18.02H	PK18.03Q	PK18.04W	PK18.05C	PK18.47N	-	-	-	-	-	-	-	-	-	-	-	-	-	
ONE	matte																			
	glossy																			
CLUB																				
WINDOW																				

## W 45

Specify hinge R or L

Code	PK18.06K	PK18.07R	PK18.08X	PK18.09D	PK18.10A	PK18.48U	PK18.49A	-	PK18.50X	PK18.51D	PK18.52L	PK18.53S	PK18.54Y	PK18.55E	PK18.56M	PK18.57T	PK18.58Z	PK18.59F	-	
ONE	matte																			
	glossy																			
CLUB																				
WINDOW																				

## W 60

Specify hinge R or L

Code	PK18.11G	PK18.12P	PK18.13V	PK18.14B	PK18.15H	PK18.60C	PK18.61K	-	PK18.62R	PK18.63X	PK18.64D	PK18.65L	PK18.66S	PK18.67Y	PK18.68E	PK18.69M	PK18.70H	PK18.71Q	PK18.16Q	
ONE	matte																			
	glossy																			
CLUB																				
WINDOW																				

Reference images →

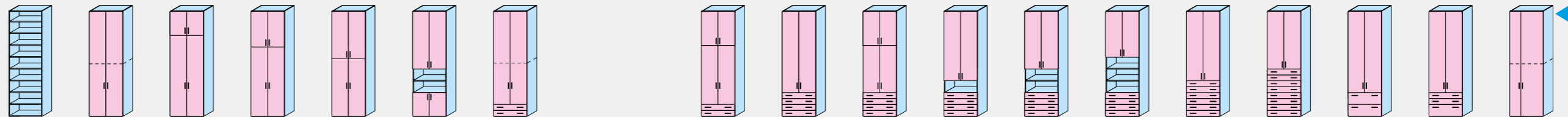

## W 90

Code	PK18.20F	PK18.21N	PK18.22U	PK18.23A	PK18.24G	PK18.79S	PK18.80P	-	PK18.81V	PK18.82B	PK18.83H	PK18.84Q	PK18.85W	PK18.86C	PK18.87K	PK18.88R	PK18.89X	PK18.90U	PK18.25P	
ONE	matte																			
	glossy																			
CLUB																				
WINDOW																				

## W 120

Drawers and big drawers CHARM with "Quadro" soft rails as standard (without surcharges)

Code	PK18.31T	PK18.32Z	PK18.33F	PK18.34N	PK18.35U	PK18.98W	PK18.99C	-	PK19.00Z	PK19.01F	PK19.02N	PK19.03U	PK19.04A	PK19.05G	PK19.06P	PK19.07V	PK19.08B	PK19.09H	-	
ONE	matte																			
	glossy																			
CLUB																				
WINDOW																				

Components in **GROUP 2 colors**  
 Components in **Types and colors FRONT**

With doors W 30  
 With doors W 30 + W 60 - Indicate R or L (drawing - R)



**OPTIONAL:** p. 86  
 A · Extra colors for Top panel, Bottom panel and Shelves  
 B · Extra colors for Side panels  
 C · Increased Back panel Th 0.8  
 D · PLUS clothes-hanging bar  
 E · Side panels with led lighting  
 F · Drawers and big drawers with soft-close

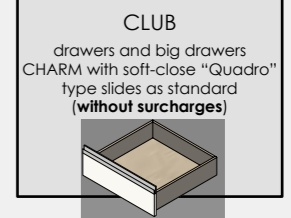

p. 44 Filler strips  
 p. 56 Knob and handle positions  
 p. 132 Accessories for Wardrobe Dpt 56.3



# Wardrobes Ht 289.6 - Dpt 56.3

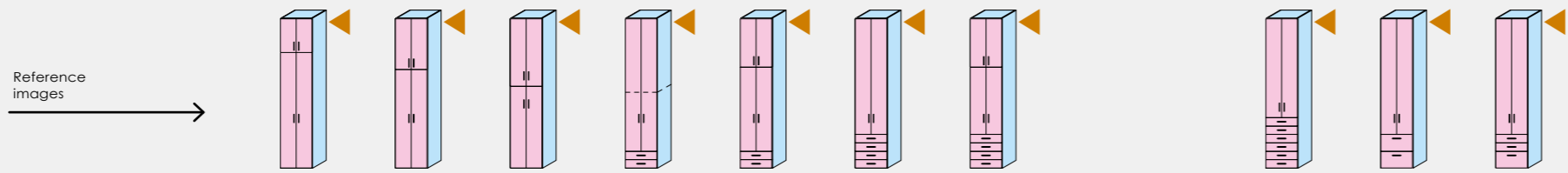

## W 30

Specify hinge  
R or L

Code	-	-	-	-	-	-	-	-	-	-	-	-	-	-	-	-	-	-
ONE	matte	-	-	-	-	-	-	-	-	-	-	-	-	-	-	-	-	-
ONE	glossy	-	-	-	-	-	-	-	-	-	-	-	-	-	-	-	-	-
CLUB		-	-	-	-	-	-	-	-	-	-	-	-	-	-	-	-	-
WINDOW		-	-	-	-	-	-	-	-	-	-	-	-	-	-	-	-	-

## W 45

Specify hinge  
R or L

Code	-	-	-	-	-	-	-	-	-	-	-	-	-	-	-	-	-	-
ONE	matte	-	-	-	-	-	-	-	-	-	-	-	-	-	-	-	-	-
ONE	glossy	-	-	-	-	-	-	-	-	-	-	-	-	-	-	-	-	-
CLUB		-	-	-	-	-	-	-	-	-	-	-	-	-	-	-	-	-
WINDOW		-	-	-	-	-	-	-	-	-	-	-	-	-	-	-	-	-

## W 60

Specify hinge  
R or L

Code	PK18.17W	PK18.18C	PK18.19K	PK18.72W	PK18.73C	PK18.74K	PK18.75R		PK18.76X	PK18.77D	PK18.78L							
ONE	matte																	
ONE	glossy																	
CLUB																		
WINDOW																		

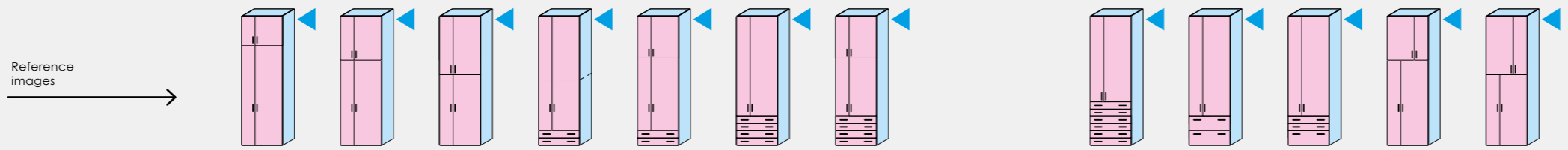

## W 90

Code	PK18.26V	PK18.27B	PK18.28H	PK18.91A	PK18.92G	PK18.93P	PK18.94V		PK18.95B	PK18.96H	PK18.97Q	PK18.29Q	PK18.30M					
ONE	matte																	
ONE	glossy																	
CLUB																		
WINDOW																		

## W 120

Drawers and big drawers  
CHARM with "Quadro" soft  
rails as standard  
(without surcharges)

Code	-	-	-	-	-	-	-	-	-	-	-	-	-	-	-	-	-	-
ONE	matte	-	-	-	-	-	-	-	-	-	-	-	-	-	-	-	-	-
ONE	glossy	-	-	-	-	-	-	-	-	-	-	-	-	-	-	-	-	-
CLUB		-	-	-	-	-	-	-	-	-	-	-	-	-	-	-	-	-
WINDOW		-	-	-	-	-	-	-	-	-	-	-	-	-	-	-	-	-

Components in **GROUP 2 colors**  
Components in **Types and colors FRONT**

With doors **W 30**  
With doors **W 30 + W 60** - Indicate R or L (drawing - R)



**OPTIONAL:**  
p. 86

- A · Extra colors for Top panel, Bottom panel and Shelves
- B · Extra colors for Side panels
- C · Increased Back panel Th 0.8
- D · PLUS clothes-hanging bar
- E · Side panels with led lighting
- F · Drawers and big drawers with soft-close

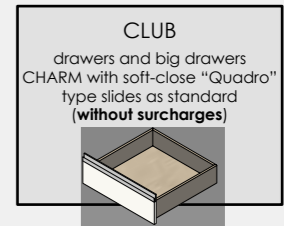

p. 44 Filler strips  
p. 56 Knob and handle positions  
p. 132 Accessories for Wardrobe Dpt 56.3

# Wardrobe compositions Dpt 56.3

## Ht 193.6

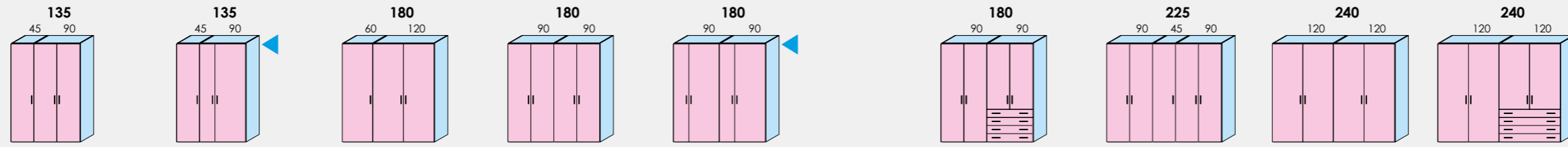

Code	PK10.75F	PK10.76N	PK10.77U	PK10.78A	PK10.79G	PK10.80D	PK10.81L	PK10.82S	PK10.83Y *		
ONE	matte										
	glossy										
CLUB											
WINDOW											

## Ht 193.6

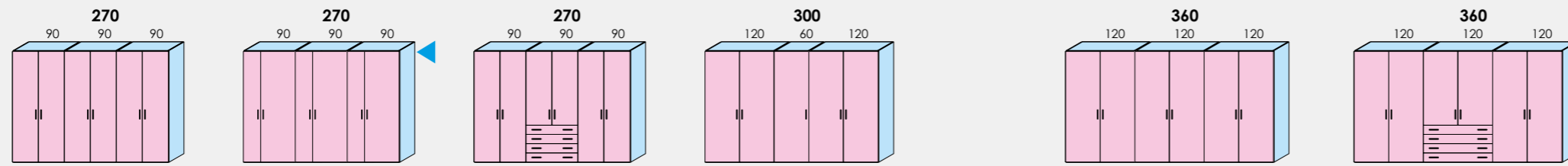

Code	PK10.84E	PK10.85M	PK10.86T	PK10.87Z	PK10.88F	PK10.89N *		
ONE	matte							
	glossy							
CLUB								
WINDOW								

## Ht 225.6

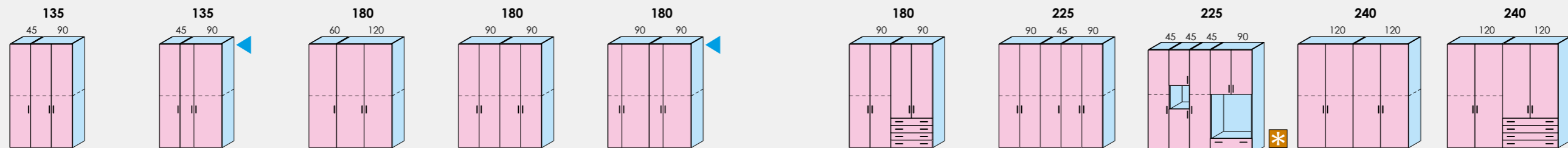

Code	PK12.81U	PK12.82A	PK12.83G	PK12.84P	PK12.85V	PK12.86B	PK12.87H	PK12.96G	PK12.88Q	PK12.89W *	
ONE	matte										
	glossy										
CLUB											
WINDOW											

## Ht 225.6

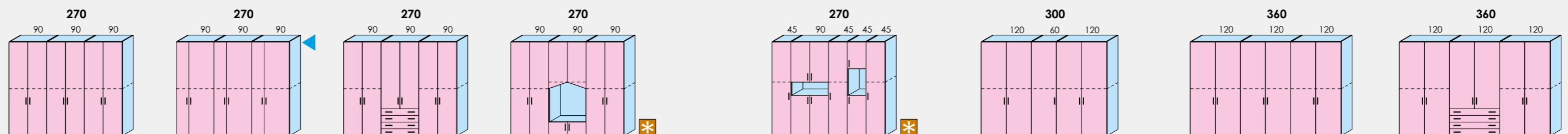

Code	PK12.90T	PK12.91Z	PK12.92F	PK12.97P	PK12.98V	PK12.93N	PK12.94U	PK12.95A *
ONE	matte							
	glossy							
CLUB								
WINDOW								

Components in **GROUP 2 colors**  
 Components in **Types and colors FRONT**  
 \* Drawers and big drawers CHARM with "Quadro" soft rails as standard (**without surcharges**)

With doors W 30 + W 60 - Indicate R or L (drawing - R)  
 All the wardrobes in the composition are equipped with an increased back panel Th 0.8

**OPTIONAL:** p. 86  
 A · Extra colors for Top panel, Bottom panel and Shelves  
 B · Extra colors for Side panels  
 C · Increased Back panel Th 0.8  
 D · PLUS clothes-hanging bar  
 E · Side panels with led lighting  
 F · Drawers and big drawers with soft-close

**CLUB**  
 drawers and big drawers CHARM with soft-close "Quadro" type slides as standard (**without surcharges**)

p. 44 Filler strips  
 p. 56 Knob and handle positions  
 p. 132 Accessories for Wardrobe Dpt 56.3

Wardrobes hinged doors

# Wardrobe compositions Dpt 56.3

## Ht 241.6

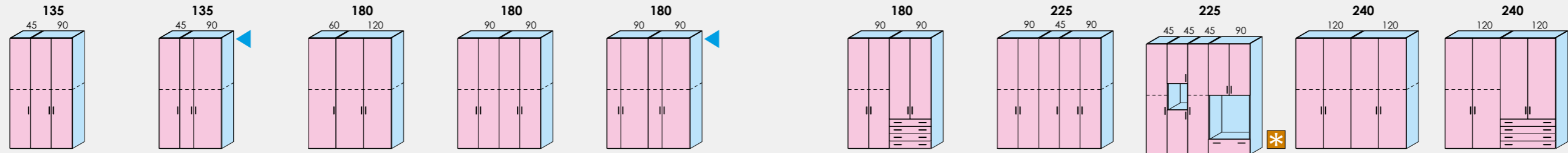

<b>Code</b>	<b>PK15.08K</b>	<b>PK15.09R</b>	<b>PK15.10N</b>	<b>PK15.11U</b>	<b>PK15.12A</b>	<b>PK15.13G</b>	<b>PK15.14P</b>	<b>PK15.23N</b>	<b>PK15.15V</b>	<b>PK15.16B *</b>	
ONE	matte										
	glossy										
CLUB											
WINDOW											

## Ht 241.6

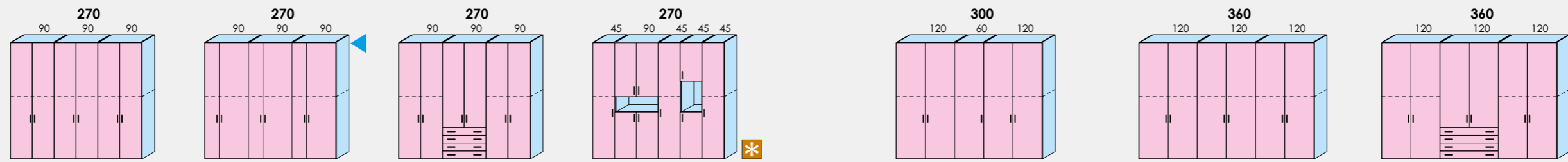

<b>Code</b>	<b>PK15.17H</b>	<b>PK15.18Q</b>	<b>PK15.19W</b>	<b>PK15.25A</b>	<b>PK15.20T</b>	<b>PK15.21Z</b>	<b>PK15.22F *</b>	
ONE	matte							
	glossy							
CLUB								
WINDOW								

## Ht 257.6

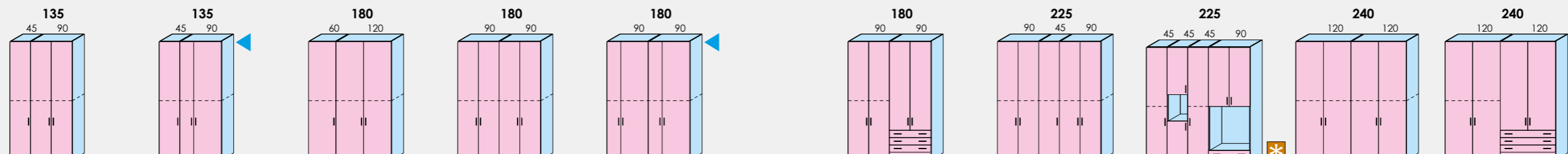

<b>Code</b>	<b>PK17.08T</b>	<b>PK17.09Z</b>	<b>PK17.10W</b>	<b>PK17.11C</b>	<b>PK17.12K</b>	<b>PK17.13R</b>	<b>PK17.14X</b>	<b>PK17.23W</b>	<b>PK17.15D</b>	<b>PK17.16L *</b>	
ONE	matte										
	glossy										
CLUB											
WINDOW											

## Ht 257.6

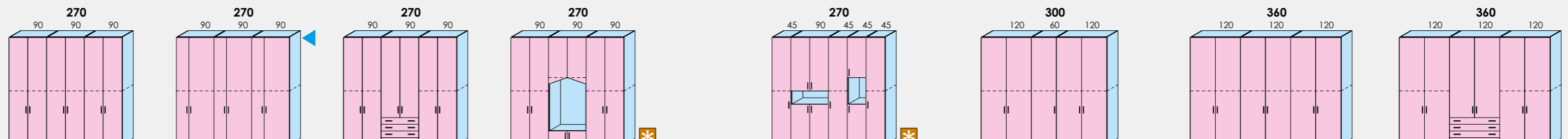

<b>Code</b>	<b>PK17.17S</b>	<b>PK17.18Y</b>	<b>PK17.19E</b>	<b>PK17.24C</b>	<b>PK17.25K</b>	<b>PK17.20B</b>	<b>PK17.21H</b>	<b>PK17.22Q *</b>
ONE	matte							
	glossy							
CLUB								
WINDOW								

- Components in **GROUP 2 colors**
- Components in **Types and colors FRONT**
- Drawers and big drawers CHARM with "Quadro" soft rails as standard (**without surcharges**)

- With doors W 30 + W 60** - Indicate R or L (drawing - R)
- All the wardrobes in the composition are equipped with an increased back panel Th 0.8



- OPTIONAL:**  
p. 86
- A** · Extra colors for Top panel, Bottom panel and Shelves
  - B** · Extra colors for Side panels
  - C** · Increased Back panel Th 0.8
  - D** · PLUS clothes-hanging bar
  - E** · Side panels with led lighting
  - F** · Drawers and big drawers with soft-close

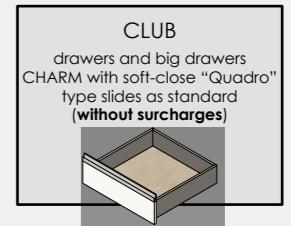

- p. 44** Filler strips
- p. 56** Knob and handle positions
- p. 132** Accessories for Wardrobe Dpt 56.3

# Wardrobe compositions Dpt 56.3

Ht 289.6

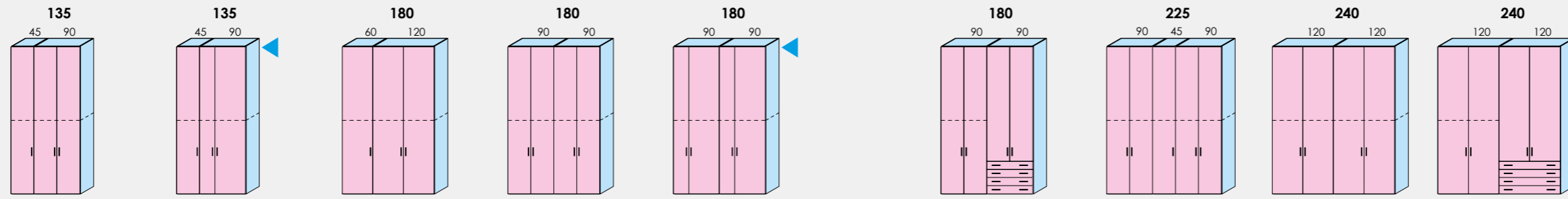

Code	PK18.36A	PK18.37G	PK18.38P	PK18.39V	PK18.40S	PK19.10E	PK18.41Y	PK18.42E	PK19.11M *		
ONE	matte										
	glossy										
CLUB											
WINDOW											

Ht 289.6

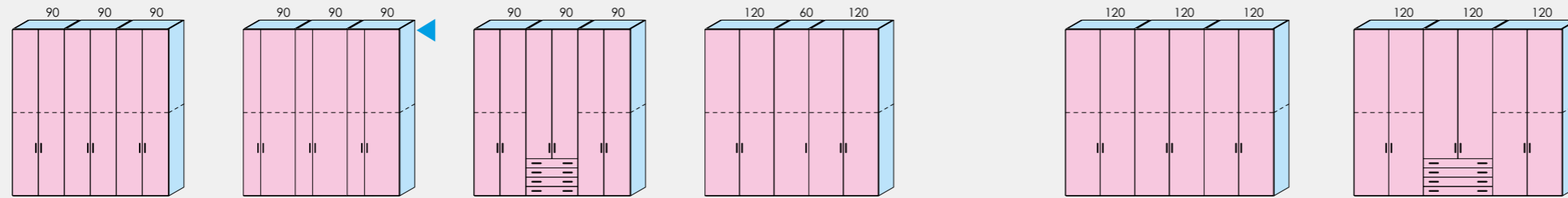

Code	PK18.43M	PK18.44T	PK19.12T	PK18.45Z	PK18.46F	PK19.13Z *		
ONE	matte							
	glossy							
CLUB								
WINDOW								

Wardrobes  
hinged doors

■ Components in **GROUP 2 colors**  
■ Components in **Types and colors FRONT**  
\* Drawers and big drawers CHARM with "Quadro" soft rails as standard (**without surcharges**)

▼ With doors W 30 + W 60 - Indicate R or L (drawing - R)

⚠ **OPTIONAL:** p. 86  
A · Extra colors for Top panel, Bottom panel and Shelves  
B · Extra colors for Side panels  
C · Increased Back panel Th 0.8  
D · PLUS clothes-hanging bar  
E · Side panels with led lighting  
F · Drawers and big drawers with soft-close

👉 p. 44 Filler strips  
 p. 56 Knob and handle positions  
 p. 132 Accessories for Wardrobe Dpt 56.3

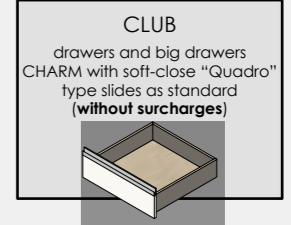

# Wardrobes Dpt 56.3 with fixed TV stand element

**A**

	Ht 193.6	Ht 225.6	Ht 241.6	Ht 257.6					
Reference images →									
<b>W 90</b>	<b>Code</b>	PK20.00P	PK20.01V	PK20.02B	PK20.03H	PK20.24A	PK20.25G	PK20.04Q	PK20.05W
	ONE	matte							
		glossy							
	CLUB								
	WINDOW								

**W 120**

Drawers and big drawers CHARM with "Quadro" soft rails as standard (without surcharges)

	Ht 193.6	Ht 225.6	Ht 241.6	Ht 257.6					
<b>W 120</b>	<b>Code</b>	PK20.06C	PK20.07K	PK20.08R	PK20.09X	PK20.26P	PK20.27V	PK20.10U	PK20.11A
	ONE	matte							
		glossy							
	CLUB								
	WINDOW								

**B**

	Ht 193.6	Ht 225.6	Ht 241.6	Ht 257.6					
Reference images →									
<b>W 90</b>	<b>Code</b>	PK20.12G	PK20.13P	PK20.14V	PK20.15B	PK20.84H	PK20.85Q	PK20.16H	PK20.17Q
	ONE	matte							
		glossy							
	CLUB								
	WINDOW								

**W 120**

Drawers and big drawers CHARM with "Quadro" soft rails as standard (without surcharges)

	Ht 193.6	Ht 225.6	Ht 241.6	Ht 257.6					
<b>W 120</b>	<b>Code</b>	PK20.18W	PK20.19C	PK20.20Z	PK20.21F	PK20.86W	PK20.87C	PK20.22N	PK20.23U
	ONE	matte							
		glossy							
	CLUB								
	WINDOW								

Components in **GROUP 2** colors  
 Components in **Types and colors FRONT**

## Technical information

- The TV can be wall-mounted or placed on a base.
- The rear panel of the TV allows you to hide the cables of the various electronic devices; it is supplied with an 8-cm diameter cable pass-through channel to be fitted in place during assembly.
- The lighting consists of a led strip (60 leds per metre), optional with surcharge, to be applied on the rear TV back band, including power supply (which can power up to 4 led strips). The type of lighting is natural. It can be switched on in 2 ways: by plugging it in and using the wall switch or by ordering a wireless switch from the price list.

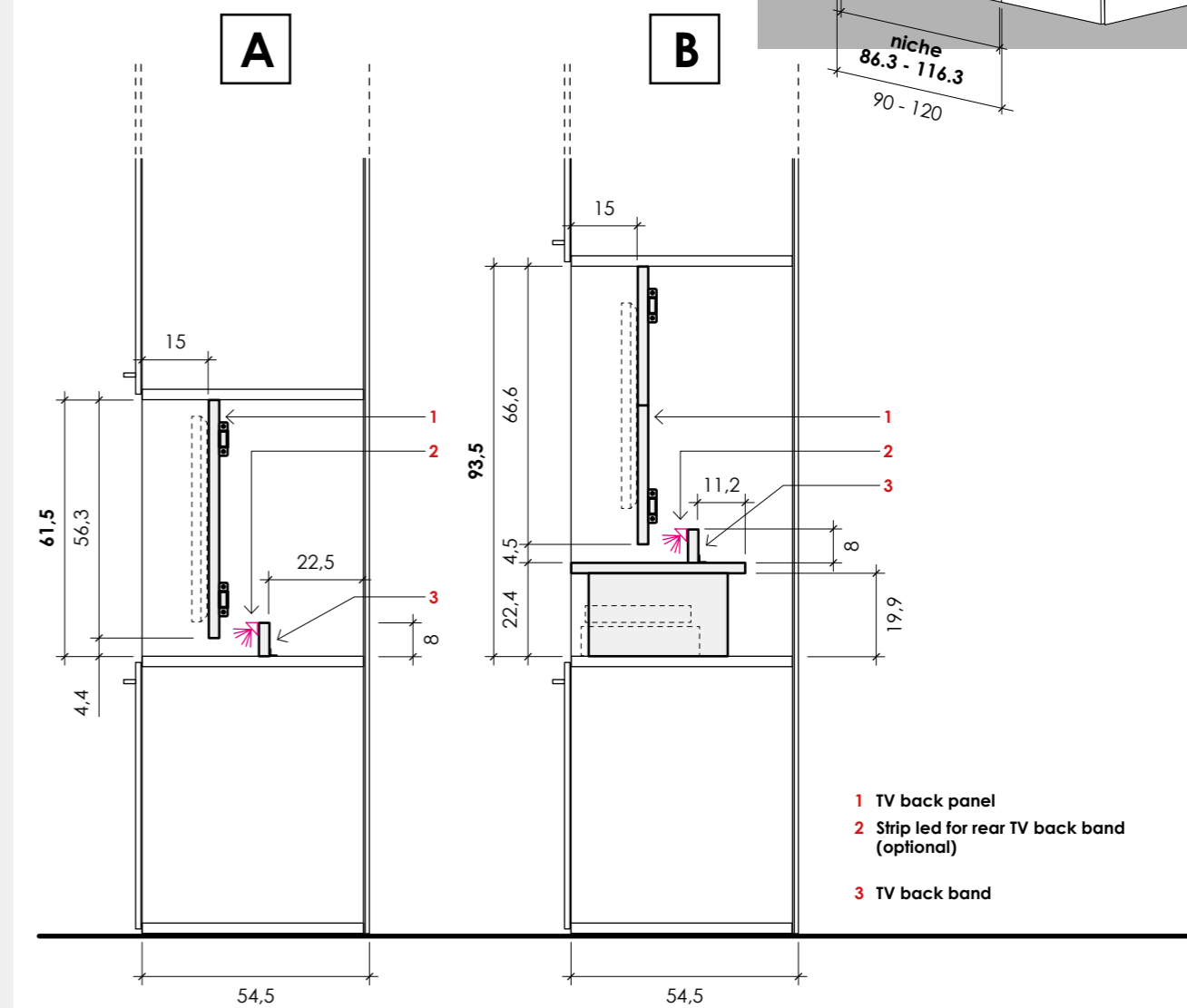
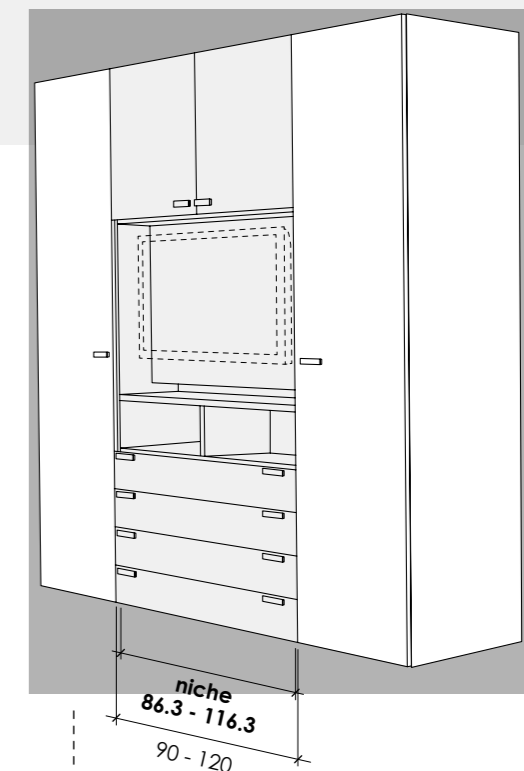

**Wireless switch**  
 For strip led for rear TV back band

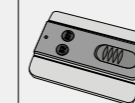

<b>Code</b>	PL86.18U
-------------	----------



- OPTIONAL: p. 86**
- A · Extra colors for Top panel, Bottom panel and Shelves
  - B · Extra colors for Side panels
  - C · Increased Back panel Th 0.8
  - D · PLUS clothes-hanging bar
  - E · Side panels with led lighting
  - F · Drawers and big drawers with soft-close

**CLUB**  
 drawers and big drawers CHARM with soft-close "Quadro" type slides as standard (without surcharges)



- p. 44 Filler strips
- p. 56 Knob and handle positions
- p. 132 Accessories for Wardrobe Dpt 56.3

Wardrobes hinged doors



# Wardrobes Dpt 56.3 with openable TV stand element

**A**

Indicate L or R for the hinge on the TV stand door (Left figure)

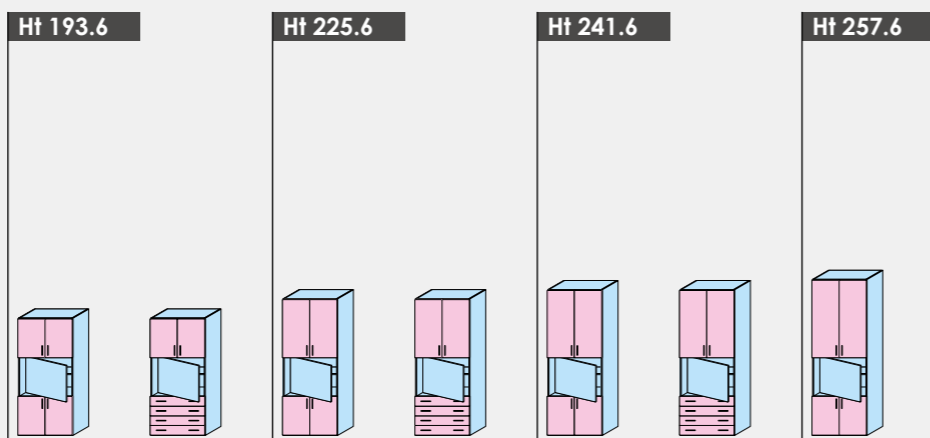

**W 90**

Code	PK25.00L	PK25.01S	PK25.02Y	PK25.03E	PK25.04M	PK25.05T	PK25.06Z	PK25.07F
ONE	matte							
	glossy							
CLUB								
WINDOW								

**W 120**

Drawers and big drawers CHARM with "Quadro" soft rails as standard (without surcharges)

Code	PK25.08N	PK25.09U	PK25.10R	PK25.11X	PK25.12D	PK25.13L	PK25.14S	PK25.15Y
ONE	matte							
	glossy							
CLUB								
WINDOW								

**B**

Indicate L or R for the hinge on the TV stand door (Left figure)

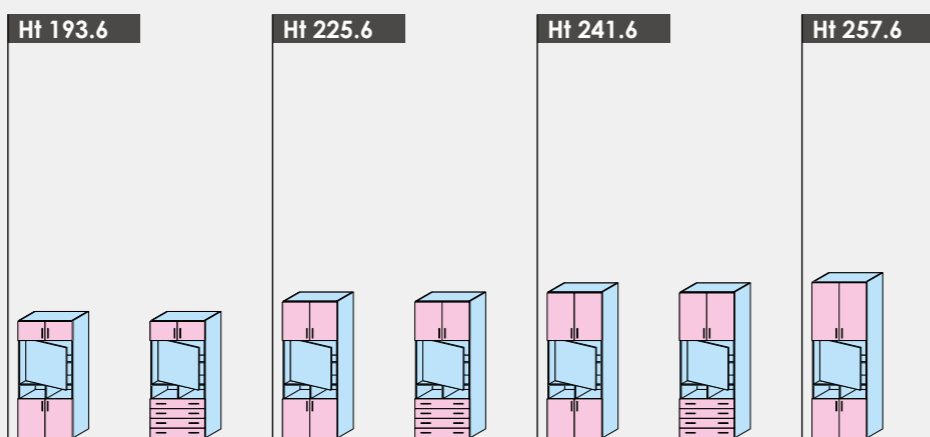

**W 90**

Code	PK25.16E	PK25.17M	PK25.18T	PK25.19Z	PK25.20W	PK25.21C	PK25.22K	PK25.23R
ONE	matte							
	glossy							
CLUB								
WINDOW								

**W 120**

Drawers and big drawers CHARM with "Quadro" soft rails as standard (without surcharges)

Code	PK25.24X	PK25.25D	PK25.26L	PK25.27S	PK25.28Y	PK25.29E	PK25.30B	PK25.31H
ONE	matte							
	glossy							
CLUB								
WINDOW								

Components in **GROUP 2** colors  
 Components in **Types and colors FRONT**

## Technical information

- TV stand door dimensions: W 85,5/115,5 - H 60,5 (A) and H 70 (B) - Th 1,8; maximum capacity 8 Kg.
- The TV stand door is equipped with: a vertical pivot and push-pull opening mechanism, cable grommet cut-out (in predefined position) and hole cover Ø 8.
- In versions with an open housing space (B), there is 1 hole cover for an additional grommet Ø 8, thus allowing cable routing from the open housing space to the TV housing space; the hole in the shelf is to be made by the client.

\* Technical compartment, not accessible

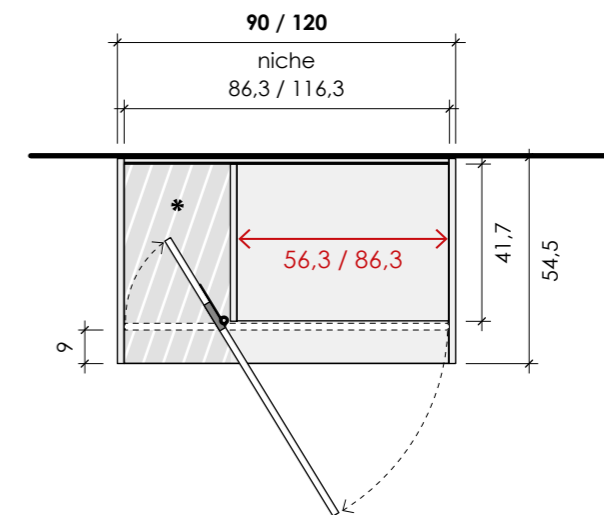

**A**

**B**

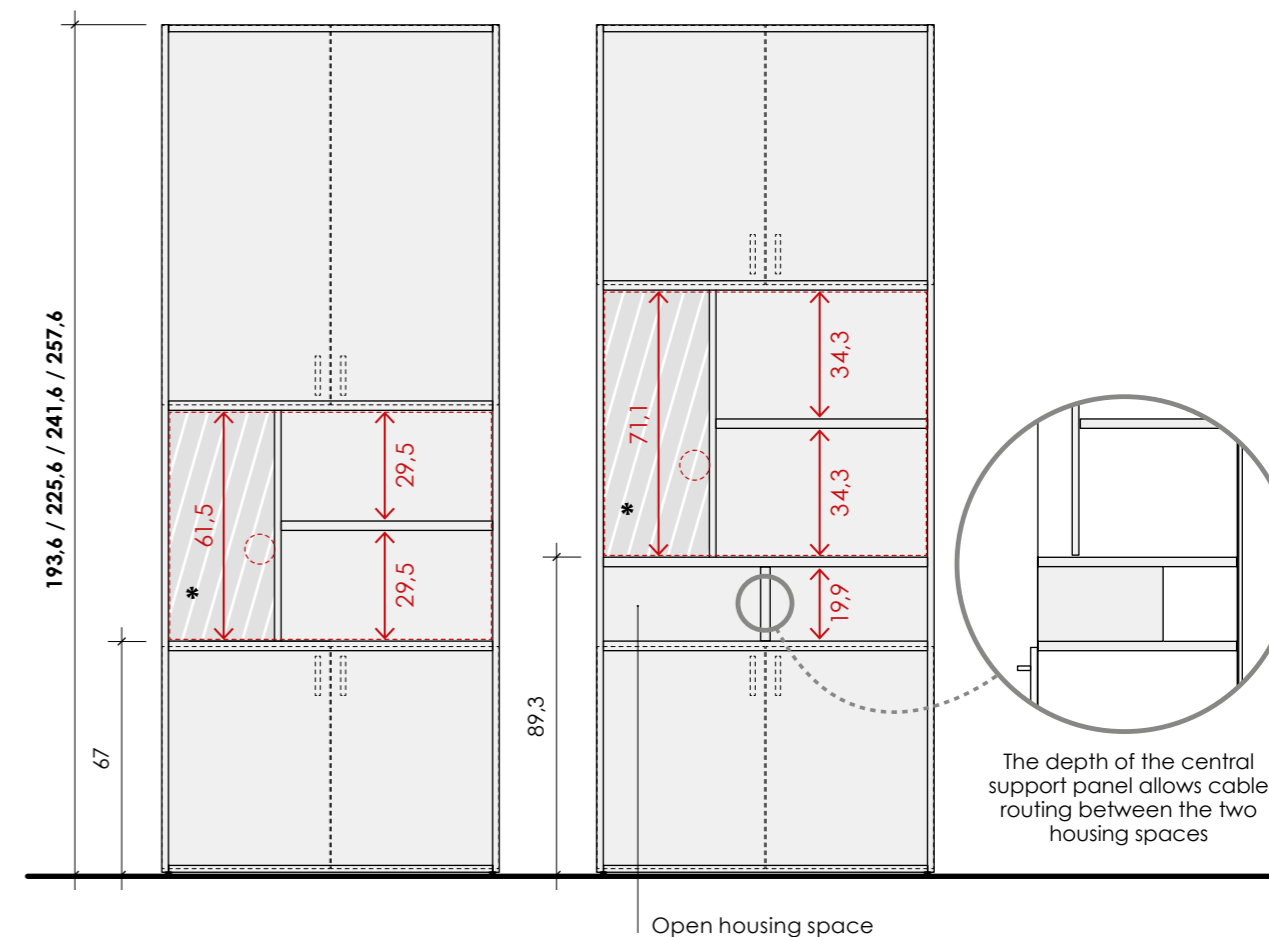

**OPTIONAL:**  
p. 86

- A · Extra colors for Top panel, Bottom panel and Shelves
- B · Extra colors for Side panels
- C · Increased Back panel Th 0,8
- D · PLUS clothes-hanging bar
- E · Side panels with led lighting
- F · Drawers and big drawers with soft-close

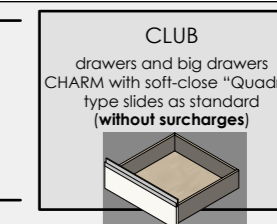

- p. 44 Filler strips
- p. 56 Knob and handle positions
- p. 132 Accessories for Wardrobe Dpt 56.3

# Wardrobes Dpt 56.3 with pull-out desk

		Ht 193.6				Ht 225.6			Ht 241.6					Ht 257.6			
<b>W 90</b>	Reference images →																
	Code	PK25.50N	PK25.51U	PK25.52A	PK25.53G	PK25.54D	PK25.55U	PK25.56B	PK25.57H	PK25.58Q	PK25.59W	PK25.60T	PK25.61Z	PK25.62F	PK25.63N	PK25.64U	PK25.65A
	ONE	matte															
		glossy															
	CLUB																
	WINDOW																
<b>W 120</b>	Code	PK25.66G	PK25.67P	PK25.68V	PK25.69B	PK25.70Y	PK25.71E	PK25.72M	PK25.73T	PK25.74Z	PK25.75F	PK25.76N	PK25.77U	PK25.78A	PK25.79G	PK25.80D	PK25.81L
	ONE	matte															
		glossy															
	CLUB																
	WINDOW																

## W 120

Drawers and big drawers CHARM with "Quadro" soft rails as standard (without surcharges)

### Informazioni tecniche

- Panel desktop Th 1.8 with metal runners with push-pull opening and a stop that holds the top in the open position.
- Once open, the top can support a maximum weight of 15 kg, evenly distributed.
- For custom cuts, see the relative chapter.

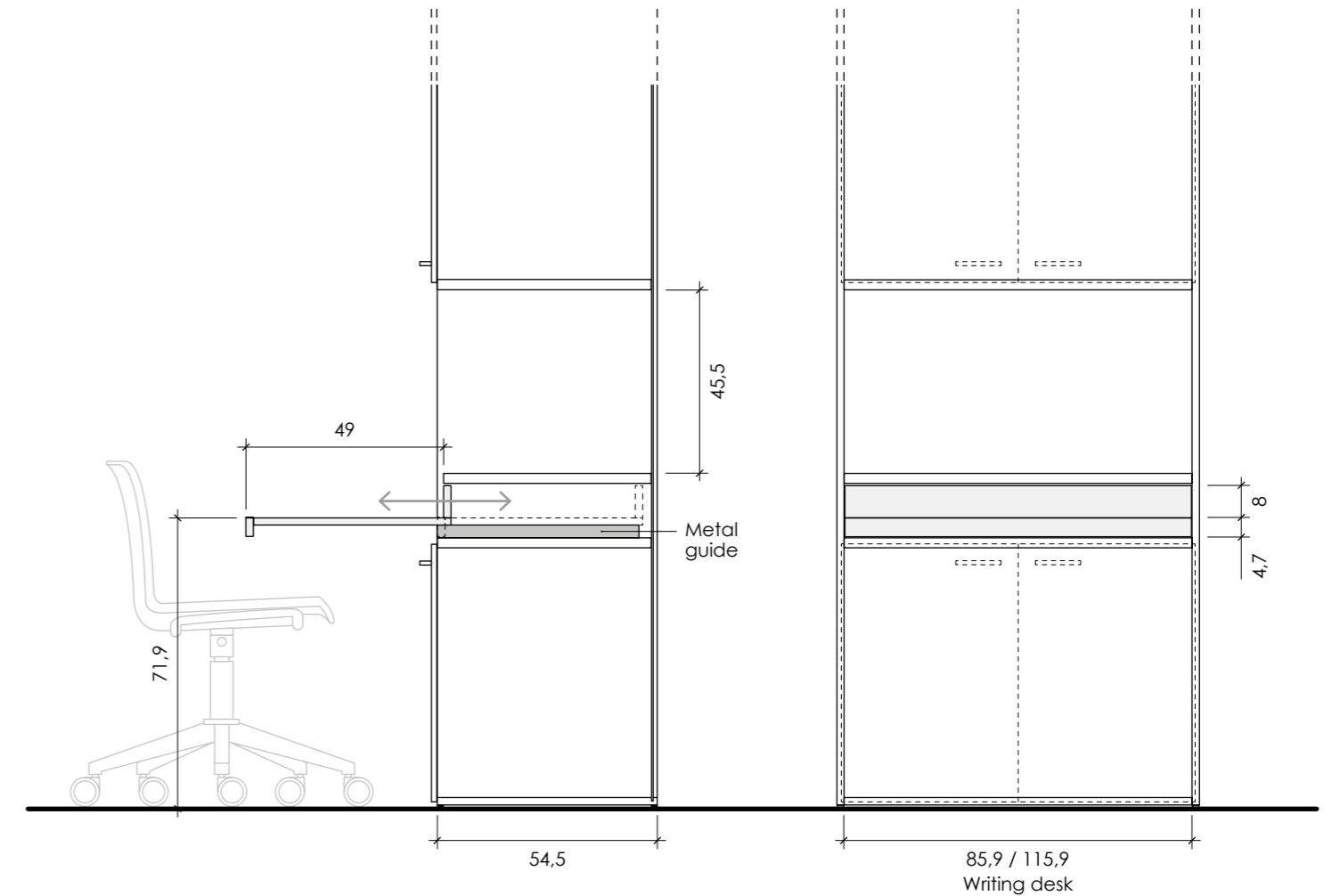

- Components in **GROUP 2 colors**
- Components in **Types and colors FRONT**



- OPTIONAL:**  
p. 86
- A · Extra colors for Top panel, Bottom panel and Shelves
  - B · Extra colors for Side panels
  - C · Increased Back panel Th 0.8
  - D · PLUS clothes-hanging bar
  - E · Side panels with led lighting
  - F · Drawers and big drawers with soft-close

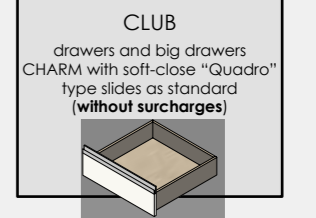

- p. 44 Filler strips
- p. 56 Knob and handle positions
- p. 132 Accessories for Wardrobe Dpt 56.3

# Over-door wardrobe Dpt 56.3

W 120

		Ht 48	Ht 80		
Reference images	→				
Code		PK05.00D	PK05.01L		
ONE	matte				
	glossy				
CLUB					

## Informazioni tecniche

- The doors have soft-close hinges.
- Bottom panel Th 2.5, back panel Th 1.8 in the Group 2 finishes
- The over-door wardrobe must always have a wardrobe on either side; it is not equipped with hangers.
- It can accommodate an inner shelf Dpt 51.5.

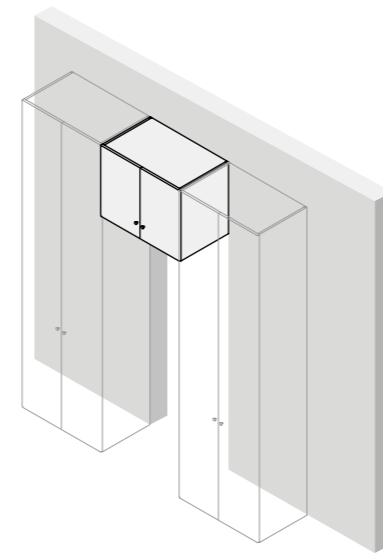

Made-to-measure reducible over-door wardrobe, when placing the order indicate the height and width of the doorway.

+ 35,00 Surcharge for each single cut.

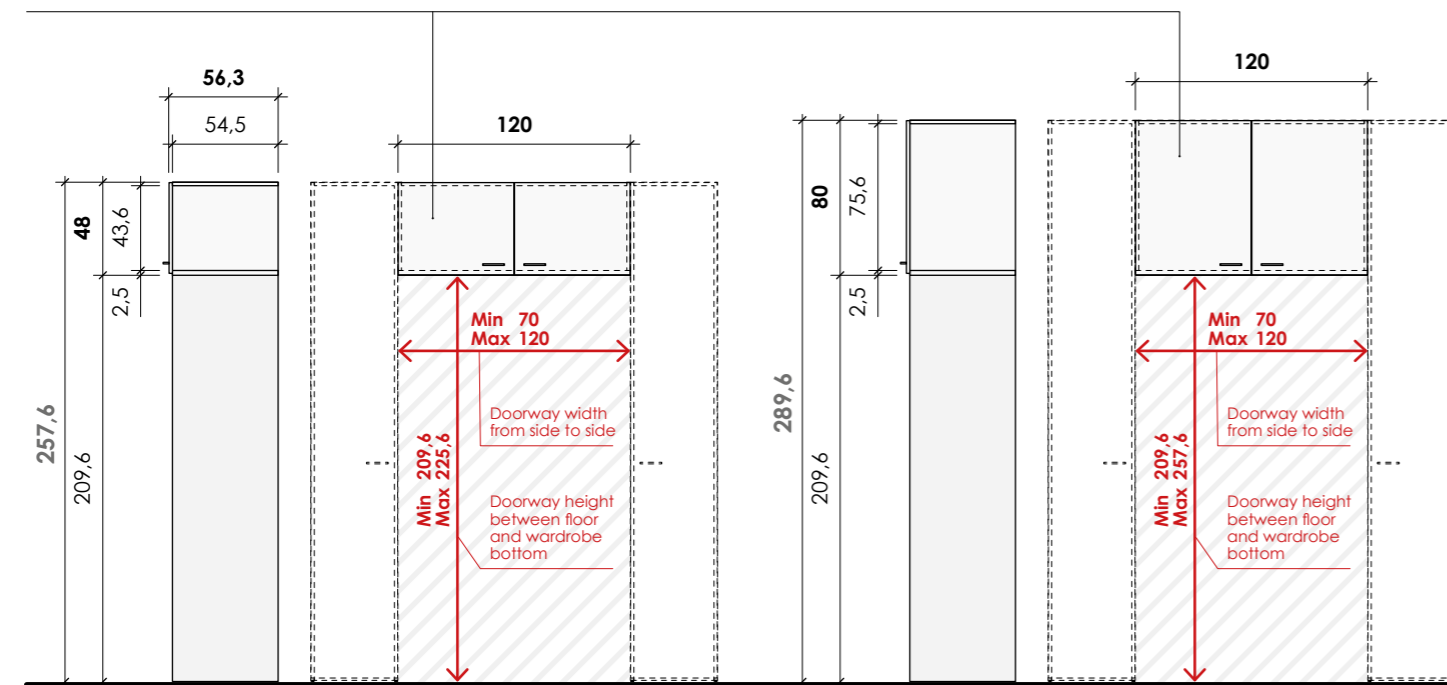

- Components in **GROUP 2 colors**
- Components in **Types and colors FRONT**



**OPTIONAL:** A · Extra colors for Top panel, Bottom panel and Shelves  
p. 86 B · Extra colors for Side panels

**CLUB**  
drawers and big drawers  
CHARM with soft-close "Quadro"  
type slides as standard  
(without surcharges)



p. 56 Knob and handle positions  
p. 132 Accessories for Wardrobe Dpt 56.3

# Accessories for wardrobe Dpt 56.3



W	Movable shelf Dpt 51.5 - Th 2.5	Dividing movable shelf Dpt 53 - Th 2.5 <i>Only for use as dividing surface between door sections and between door sections and drawers/large drawers.</i>	Inner drawer units Drawers Ht 16 Dpt 45.8	Inner drawer unit Drawers Ht 21.3 Dpt 45.8	Pull-out basket Ht 12 - Dpt 50	BASIC clothes hanging bar	PLUS clothes hanging bar
Code	Code	Code	Code	Code	Code	Code	Code
30 (26.3) *	-	PK01.05U	-	-	-	-	PK01.42W
45 (41.3) *	PK01.01T	PK01.06A	PK01.10S	PK01.13M	PK01.16F	PK01.19A	PK01.43C
60 (56.3) *	PK01.02Z	PK01.07G	PK01.11Y	PK01.14T	PK01.17N	PK01.20X	PK01.44K
90 (86.3) *	PK01.03F	PK01.08P	PK01.12E	PK01.15Z	PK01.18U	PK01.21D	PK01.45R
120 (116.3) *	PK01.04N	PK01.09V	-	-	-	-	PK01.46X

W 90	Movable transparent glass shelf Dpt 51 - Th 0.8	Cantilever clothes rail Ht 84	Pull-out shoe rack Dpt 46.5 Ht 17.2	Metal pull-out basket Dpt 46.5 Ht 12.4	Pull-out pant rack Dpt 46.5 Ht 8	Pull-out tie/belt rack + pant rack Dpt 46.5 Ht 8	2 pull-out fabric laundry baskets Dpt 46.5 Ht 41.5	Inner drawer unit Drawers Ht 18.5 with frame and glass Dpt 45.8	Tie rack hooks Can be inserted where the icon is shown W 42	Coin tray Can be inserted where the icon is shown W 42	Example of pant rack with tie rack hooks and coin tray.
Code	Code	Code	Code	Code	Code	Code	Code	Code	Code	Code	Code
*	PL04.13B	P02.58M	P07.04K	P07.05Q	P07.07A	P07.08F	P07.10S	PK01.22L	P07.12C	P07.13H	

W 120	Cantilever clothes rail with spacers Ht 84	Equipped honeycomb structures W 116.3 - Dpt 45.8 - Ht 68.3	With pull-out shoe rack	With metal pull-out basket	With pull-out pant rack	With pull-out tie and belt rack + pant rack	With 2 pull-out fabric laundry baskets	With shelf	With transparent glass shelf	With inner drawer unit Drawers Ht 21.3	With inner drawer unit Drawers Ht 16	With inner drawer unit Drawers Ht 18.5 with frame and glass
Code	Code	Code	Code	Code	Code	Code	Code	Code	Code	Code	Code	Code
*	P02.59S	PK01.23S	PK01.24Y	PK01.25E	PK01.26M	PK01.27T	PK01.28Z	PK01.29F	PK01.30C	PK01.31K	PK01.32R	PK01.32R

W 120	Wardrobe seperators with clothes hanging bar BASIC* * If can be replaced with the PLUS W 90 (with surcharge). W 116.3 - Dpt 45.8	Shelf for Wardrobe seperators W 86.3 - Dpt 45.8 - Th 2.5	Movable transparent glass shelf for Wardrobe seperators W 86.3 - Dpt 41.2 - Th 0.8	WARDROBE PARTITIONS Including clothes rail W 86.3 and shelves W 27.5 Internal compartment W 86.3. Can be fitted with accessories for 90 cm wide wardrobes and with shelves for Wardrobe seperators. Storage compartments and wardrobe partitions can only be added to the bottom of the wardrobe.			
Code	Code	Code	Code	Code			
*	PK01.33X	PK01.34D	PK01.35L	PK01.36S	PK01.37Y	P51.75M	

Components in GROUP 2 colors  
 RW3Q RD5T CB6K GZ8T  
 AL1A GZ8T

\* Price of the element in GROUP 2 colors (CARCASE colors excluded)

**OPTIONAL:** p. 86  
 D - PLUS clothes rail (for Wardrobe seperator)

p. 56 Knob and handle positions

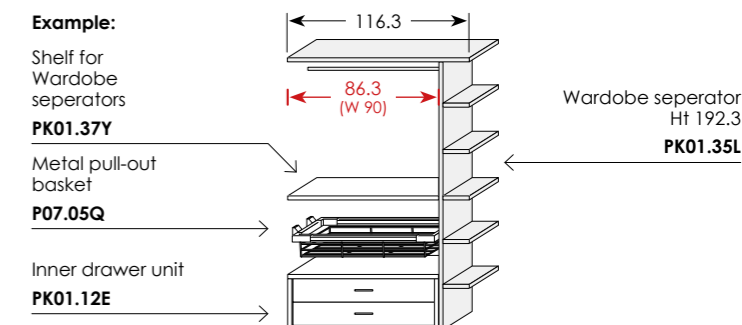



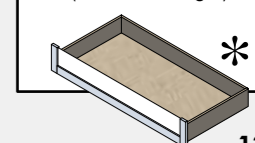

With soft-close adjustable height "Quadro" type metal slides. Drawers internal color CHARM (without surcharges)

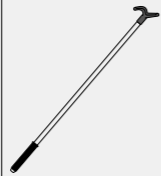
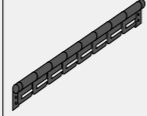
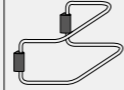

Wardrobes hinged doors

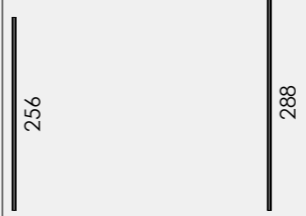
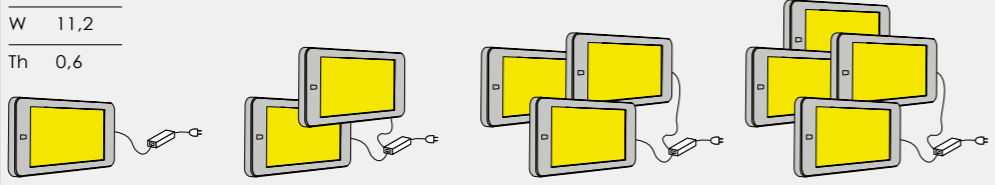
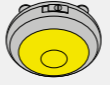
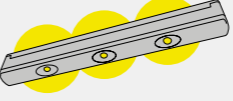
# Accessories for wardrobe Dpt 56.3

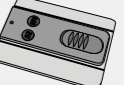
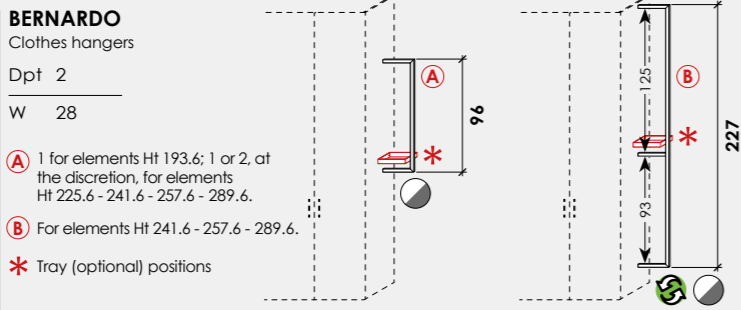
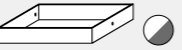
	<p><b>Sliding clothes rail</b> Recommended for wardrobes with small depth: Dpt 40 = for depth greater than 40 cm. Dpt 24.5 = for depth less than 40 cm.</p> 	<p><b>Metal clothes reacher pole</b> Ht 115</p> 	<p><b>Tie hanging rack</b> W 35.2 For mounting on inside of door</p> 	<p><b>Hanging shoe rack</b> W 45 ÷ 70 For mounting on inner side</p> 	<p><b>Inside mirror for door</b> W 45/60 Ht 147 - W 32</p> 	<p><b>Dust guard for pair hinged doors</b> Aluminium colour only</p> 					
<b>Code</b>	<b>P50.95S</b>	<b>P48.50W</b>	<b>PL04.17C</b>	<b>P48.58Q</b>	<b>P48.55Y</b>	<b>P30.44L</b>	<b>P01.13P</b>	<b>P01.70Y</b>			
	<p><b>Lighting with sensor</b> Complete kits with 1 Power pack. Cover color Aluminum and Titanium.</p> <p>Dpt 19,2 W 11,2 Th 0,6</p> 				<p><b>Led lamp SPARK</b> Ø 9.1 - Th 4.4 Manual switch or light sensor that can be operated with the side switch. Can be applied with the provided screws or with biadhesive Velcro. 3 - 1.5v AAA batteries not included.</p> 	<p><b>Led lamp SKY</b> W 17 - Ht 2.2 - Dpt 1.5 Built-in touch switch. Can be applied with the provided screws or with biadhesive tape. 3 - 1.5v AAA batteries not included.</p> 	<p><b>Led spotlights Ø 6.5</b> We provide a power pack (with a sur-charge) able to support from 1 to 6 spotlights. 12 volt 1.7 watt.</p> 	<p><b>Wireless switch</b> For led spotlights Ø 6.5.</p> 			
<b>Code</b>	<b>P08.71B</b>	<b>P08.72G</b>	<b>P08.73N</b>	<b>P08.74T</b>	<b>P07.30A</b>	<b>P07.31F</b>	<b>PL86.17N</b>	<b>PL86.18U</b>			
	<p><b>BERNARDO</b> Clothes hangers Dpt 2 W 28</p> <p>A 1 for elements Ht 193.6; 1 or 2, at the discretion, for elements Ht 225.6 - 241.6 - 257.6 - 289.6. B For elements Ht 241.6 - 257.6 - 289.6. * Tray (optional) positions</p> 			<p><b>Tray</b> Ht 4 Dpt 15 W 25</p> 							
<b>Code</b>		<b>P07.70T</b>	<b>P08.31K</b>	<b>P08.32Q</b>							

Wardrobes hinged doors

- Components in **Types and colors FRONT**
- The element can be turned upside down
- 
- B17A  GZ8T



# Corner wardrobe units Dpt 56.3 - W 99.6 x 101.3

## Ht 193.6

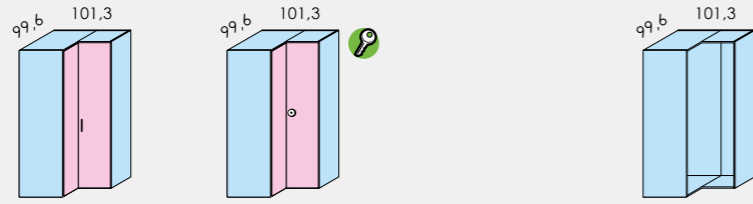

<b>Code</b>	<b>PK11.45U</b>	<b>PK11.46A</b>	<b>PK11.47G</b>		
ONE	matte				
	glossy				
CLUB					

## Ht 225.6

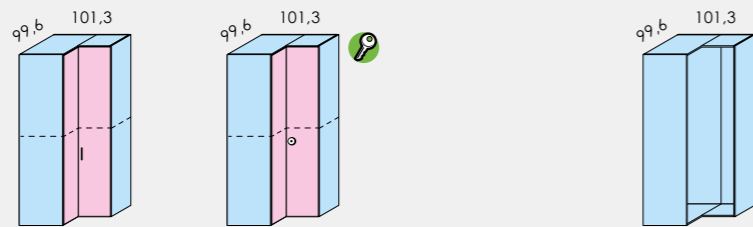

<b>Code</b>	<b>PK13.45C</b>	<b>PK13.46K</b>	<b>PK13.47R</b>		
ONE	matte				
	glossy				
CLUB					

## Ht 241.6

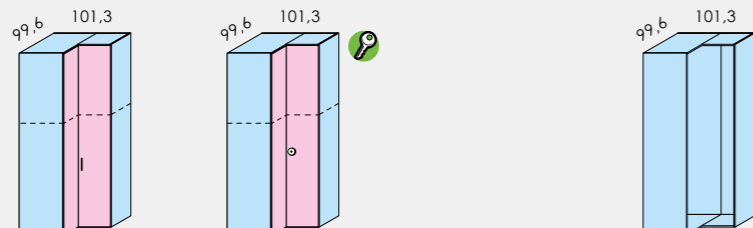

<b>Code</b>	<b>PK15.45M</b>	<b>PK15.46T</b>	<b>PK15.47Z</b>		
ONE	matte				
	glossy				
CLUB					

## Ht 257.6

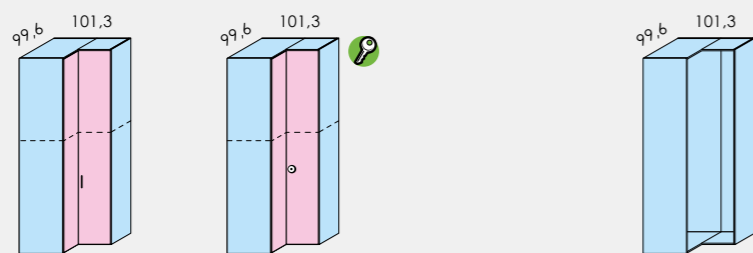

<b>Code</b>	<b>PK17.45V</b>	<b>PK17.46B</b>	<b>PK17.47H</b>		
ONE	matte				
	glossy				
CLUB					

- Components in **GROUP 2 colors**
- Components in **Types and colors FRONT**
- AL1A GZ8T**
- Element complete with lock bar lock.

\* Price of the element in GROUP 2 colors (CARCASE colors excluded)

## Ht 289.6

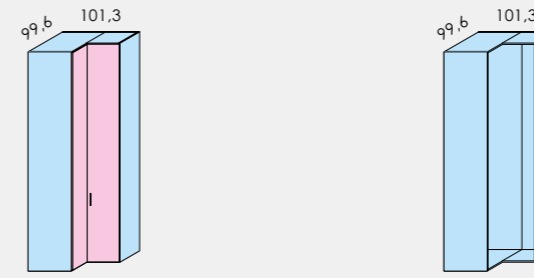

<b>Code</b>	<b>PK15.49N</b>	<b>PK15.50K</b>			
ONE	matte				
	glossy				
CLUB					

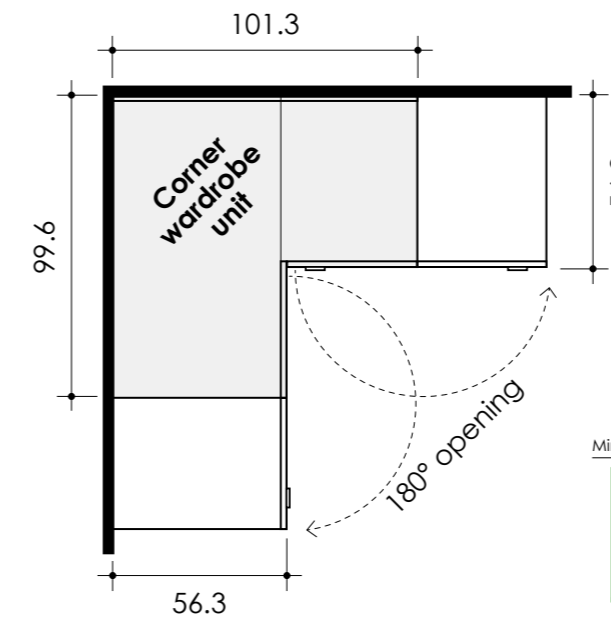

### Technical information

- They are equipped with adjustable feet.
- The doors are with decelerated hinges.
- The dimensions cannot be inverted. The handle is always on the R door.
- Internal fittings supplied consist in: a pair of clothes hanging bars in units Ht 193.6; a shelf and two pairs of clothes hanging bars in units Ht 225.6 - 241.6 - 257.6 - 289.6.
- So as to be able to open the doors fully we recommend placing W 45/60 elements in the corner with the hinges facing the corner itself and/or W 90 elements without drawers.
- For positioning units with a depth greater than 56.3 cm (example, beds, sofas, etc.) next to a corner wardrobe unit, observe the minimum distances indicated below.
- **For custom cuts consult the relevant chapter.**

	<b>Movable corner shelf</b> Dpt 51,5 Th 2,5 	<b>BASIC corner clothes hanging bars</b> 	<b>PLUS corner clothes hanging bars</b> 	<b>Metal clothes reacher stick</b> Ht 115 	<b>Hanging shoe rack</b> For mounting on inner side W 45 ÷ 70 
<b>Code</b>	<b>PK01.41Q</b>	<b>P50.78Z</b>	<b>PK01.51V</b>	<b>PL04.17C</b>	<b>P48.55Y</b>
	*				

	<b>Mirror for inside of door</b> Ht 147 W 32 	<b>Tie hanging rack</b> For mounting on inside of door W 35,2 		
<b>Code</b>	<b>P30.44L</b>	<b>P48.58Q</b>		

- OPTIONAL: p. 86**
- A · Extra colors for Top panel, Bottom panel and Shelves
  - B · Extra colors for Side panels
  - C · Increased Back panel Th 0.8
  - D · PLUS clothes-hanging bar
  - E · Side panels with led lighting

**p. 56** Knob and handle positions

# Corner wardrobes Dpt 56.3 - W 90 with opening door W 45

## Ht 193.6

L in drawing

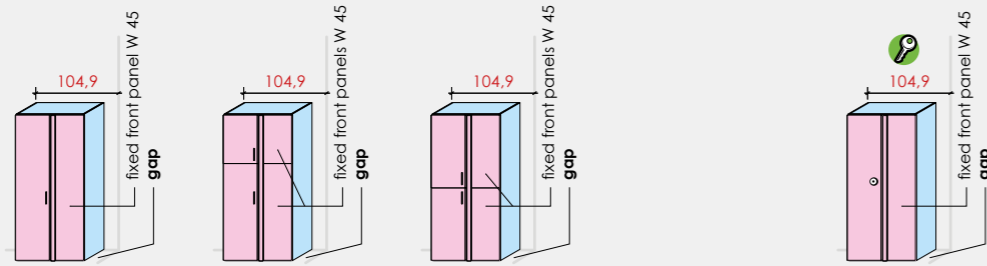

Code	L	PK11.51Y	PK11.52E	PK11.53M		PK11.55Z
	R	PK11.56F	PK11.57N	PK11.58U		PK11.60X
ONE	matte					
	glossy					
CLUB						

## Ht 225.6

L in drawing

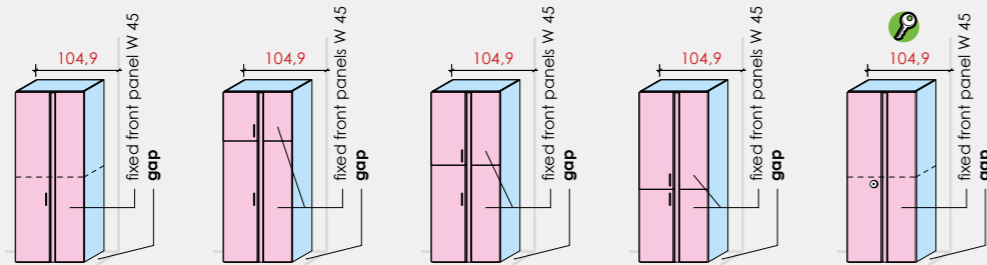

Code	L	PK13.51G	PK13.52P	PK13.53V	PK13.54B	PK13.55H
	R	PK13.56Q	PK13.57W	PK13.58C	PK13.59K	PK13.60F
ONE	matte					
	glossy					
CLUB						

## Ht 257.6

L in drawing

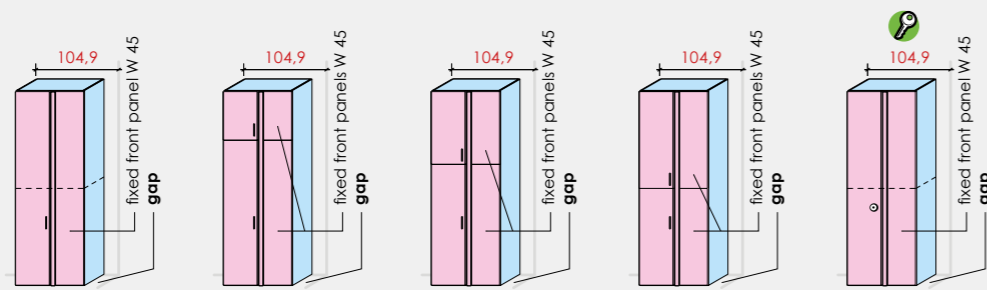







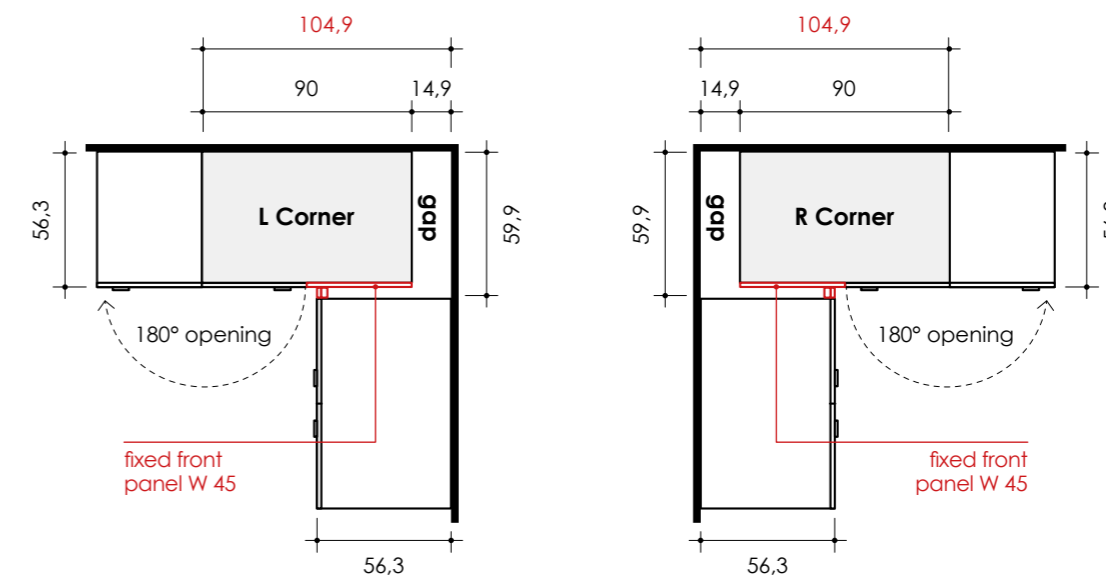

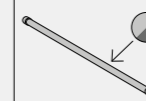

Code	L	PK17.51Z	PK17.52F	PK17.53N	PK17.54U	PK17.55A
	R	PK17.56G	PK17.57P	PK17.58V	PK17.59B	PK17.60Y
ONE	matte					
	glossy					
CLUB						

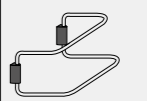
### Technical information

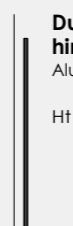
- They are equipped with adjustable feet.
- The doors are with decelerated hinges.
- Internal fittings supplied consist in: 1 clothes hanging bar in line with doors Ht 96 - 128 - 160 - 192; 2 clothes hanging bars and 1 movable shelf in line with doors Ht 224 - 256.
- For custom cuts consult the relevant chapter.



	<b>Movable shelf</b> Dpt 51,5 Th 2,5 	<b>BASIC clothes hanging bar</b> W 86,3 	<b>PLUS clothes hanging bar</b> W 86,3 	<b>Metal clothes reacher stick</b> Ht 115 	<b>Hanging shoe rack</b> For mounting on inner side W 45 ÷ 70 
Code	PK01.03F	P50.81R	PK01.45R	PL04.17C	P48.55Y
	*				
	<b>Mirror for inside of door</b> Ht 147 W 32 	<b>Tie hanging rack</b> For mounting on inside of door W 35,2 	<b>Dust guard for pair hinged doors</b> Aluminium colour only Ht 256 		
Code	P30.44L	P48.58Q	P01.13P		

-  Components in **GROUP 2 colors**
-  Components in **Types and colors FRONT**
-  **AL1A GZ8T**
-  Element complete with bar lock.

\* Price of the element in GROUP 2 colors (CARCASE colors excluded)



**OPTIONAL:**  
p. 86

- A · Extra colors for Top panel, Bottom panel and Shelves
- B · Extra colors for Side panels
- C · Increased Back panel Th 0.8
- D · PLUS clothes-hanging bar
- E · Side panels with led lighting



p. 56 Knob and handle positions

# Corner wardrobes Dpt 56.3 - W 90 with opening door W 60

## Ht 193.6

L in drawing

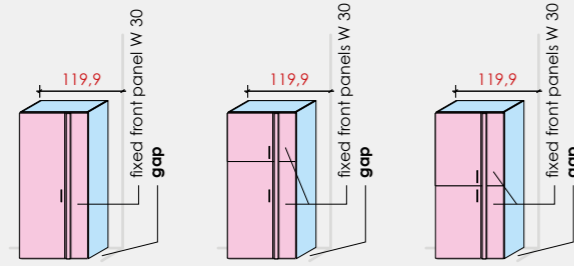

Code	L	PK11.61D	PK11.62L	PK11.63S		
	R	PK11.65E	PK11.66M	PK11.67T		
ONE	matte					
	glossy					
CLUB						

## Ht 225.6

L in drawing

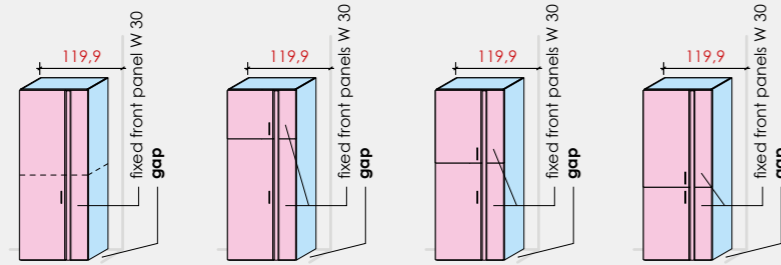

Code	L	PK13.61N	PK13.62U	PK13.63A	PK13.64G	
	R	PK13.65P	PK13.66V	PK13.67B	PK13.68H	
ONE	matte					
	glossy					
CLUB						

## Ht 257.6

L in drawing

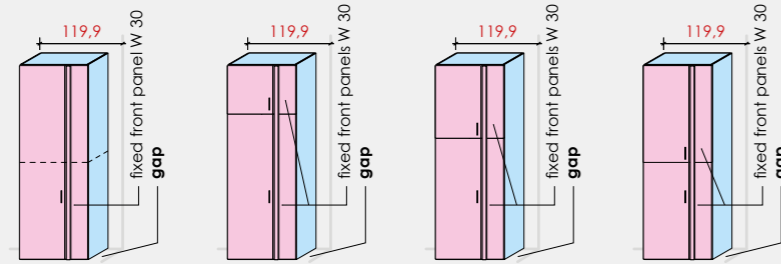







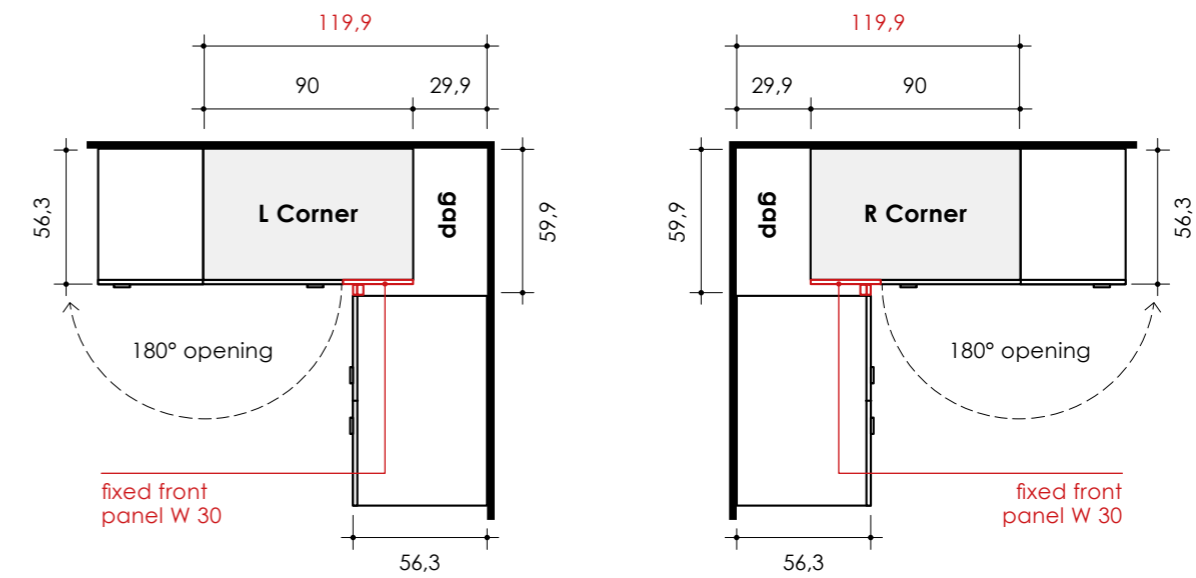





Code	L	PK17.61E	PK17.62M	PK17.63T	PK17.64Z	
	R	PK17.65F	PK17.66N	PK17.67U	PK17.68A	
ONE	matte					
	glossy					
CLUB						

### Technical information

- They are equipped with adjustable feet.
- The doors are with decelerated hinges.
- Internal fittings supplied consist in: 1 clothes hanging bar in line with doors Ht 96 - 128 - 160 - 192; 2 clothes hanging bars and 1 movable shelf in line with doors Ht 224 - 256.
- For custom cuts consult the relevant chapter.



	<b>Movable shelf</b> Dpt 51,5 Th 2,5 	<b>BASIC clothes hanging bar</b> W 86,3 	<b>PLUS clothes hanging bar</b> W 86,3 	<b>Metal clothes reacher stick</b> Ht 115 	<b>Hanging shoe rack</b> For mounting on inner side W 45 ÷ 70 
Code	PK01.03F	P50.81R	PK01.45R	PL04.17C	P48.55Y
	*				
	<b>Mirror for inside of door</b> Ht 147 W 32 	<b>Tie hanging rack</b> For mounting on inside of door W 35,2 	<b>Dust guard for pair hinged doors</b> Aluminium colour only Ht 256 		
Code	P30.44L	P48.58Q	P01.13P		

 Components in **GROUP 2 colors**  
 Components in **Types and colors FRONT**  
 AL1A  GZ8T

\* Price of the element in GROUP 2 colors (CARCASE colors excluded)



**OPTIONAL:**  
p. 86

- A · Extra colors for Top panel, Bottom panel and Shelves
- B · Extra colors for Side panels
- C · Increased Back panel Th 0.8
- D · PLUS clothes-hanging bar
- E · Side panels with led lighting



p. 56 Knob and handle positions

# External corner wardrobes Dpt 56.3 - W 56.3

## Ht 193.6

R in drawing

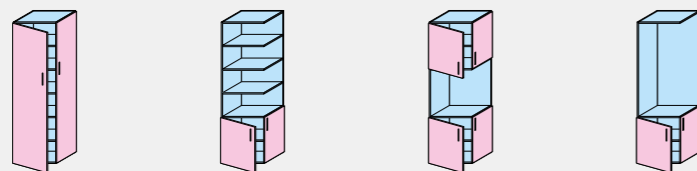

Code	L	PK42.00D	PK42.01L	PK42.02S	PK42.03Y		
	R	PK42.04E	PK42.05M	PK42.06T	PK42.07Z		
ONE	matte						
	glossy						
CLUB							

## Ht 225.6

R in drawing

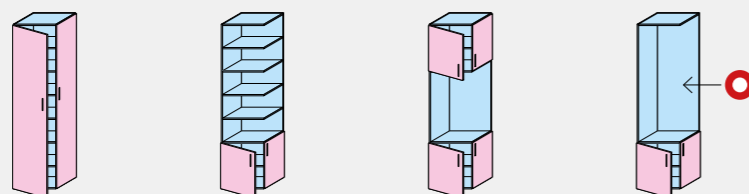

Code	L	PK42.08F	PK42.09N	PK42.10K	PK42.11R		
	R	PK42.12X	PK42.13D	PK42.14L	PK42.15S		
ONE	matte						
	glossy						
CLUB							

## Ht 241.6

R in drawing

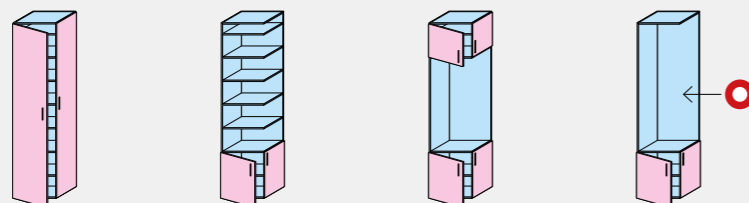

Code	L	PK42.16Y	PK42.17E	PK42.18M	PK42.19T		
	R	PK42.20Q	PK42.21W	PK42.22C	PK42.23K		
ONE	matte						
	glossy						
CLUB							

## Ht 257.6

R in drawing

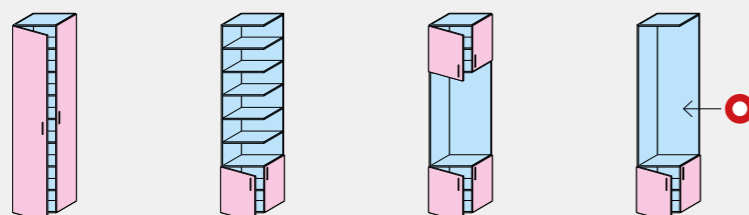

Code	L	PK42.24R	PK42.25X	PK42.26D	PK42.27L		
	R	PK42.28S	PK42.29Y	PK42.30V	PK42.31B		
ONE	matte						
	glossy						
CLUB							

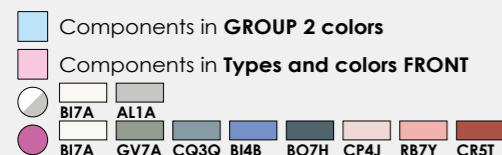

\* Price of the element in GROUP 2 colors (CARCASE colors excluded)

### Technical information

- They are equipped with adjustable feet.
- The doors have soft-close hinges.
- They must be positioned between two wardrobes (see example).
- Max load per inner shelf 7 kg, evenly distributed.
- For custom cuts, see the relative chapter.

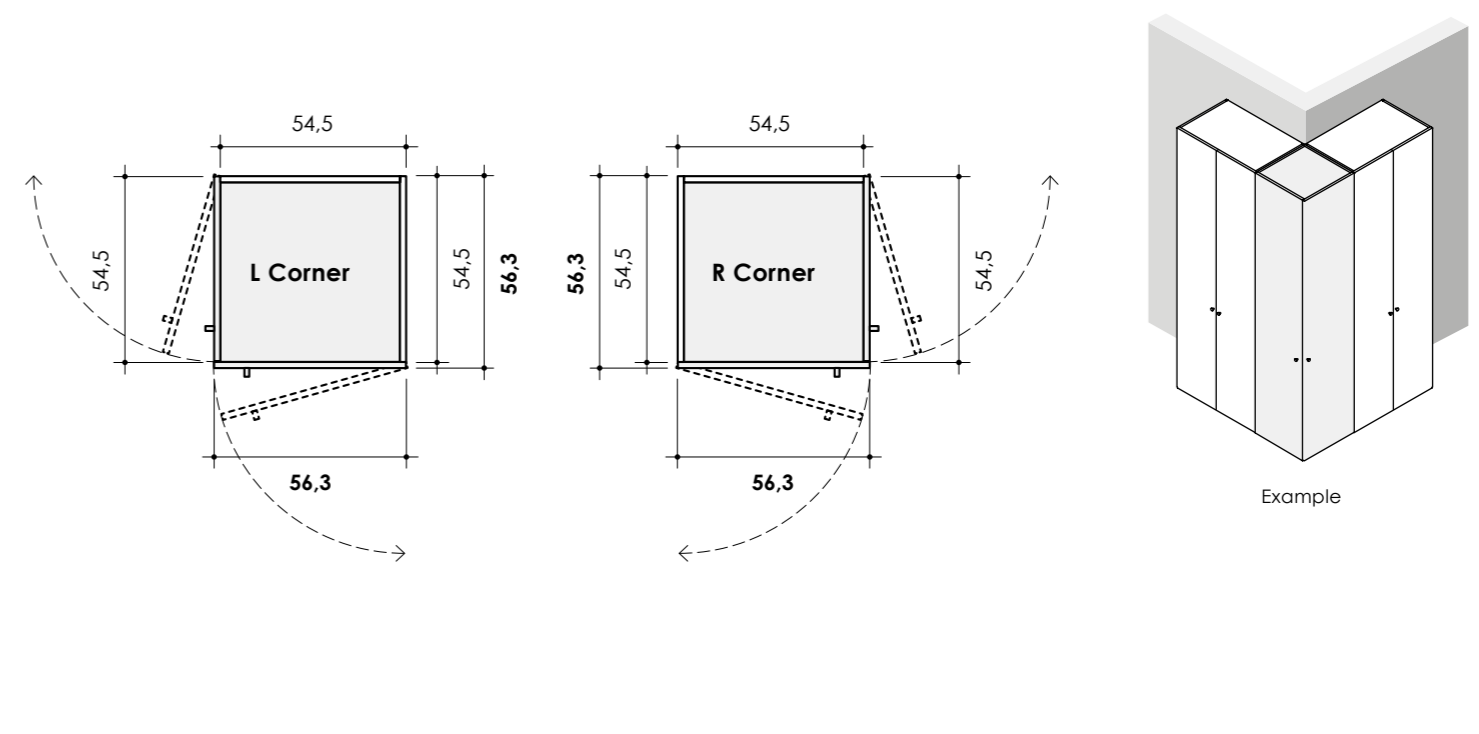

	<b>Movable inner shelf</b> Th 2,5 	<b>Clothes hooks BOLLINO</b> Dpt 4 Ø 10 	<b>Clothes hooks TWIN</b> Ht 12,7 W 3,4 Dpt 5,2 	<b>Mirror for inside of door</b> Ht 147 W 32 	<b>Round mirror</b> With biadhesive tape Ø 30 
Code	PK02.04S	P40.51A	P71.62V	P30.44L	P99.19S
	*				

- OPTIONAL:** p. 86
- A · Extra colors for Top panel, Bottom panel and Shelves
  - B · Extra colors for Side panels
  - E · Side panels with led lighting

# Filler strip 5.4 - 5.4 (for empty corners)

Ht 193.6      Ht 225.6      Ht 241.6      Ht 257.6

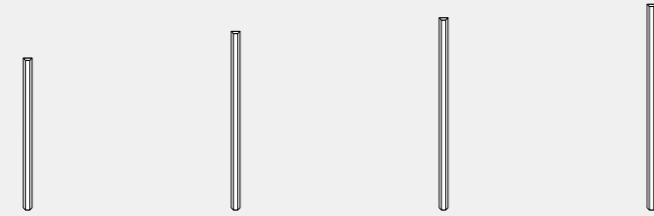

Code	PK11.48P	PK13.48X	PK15.48F	PK17.48Q		
------	----------	----------	----------	----------	--	--

## Technical information

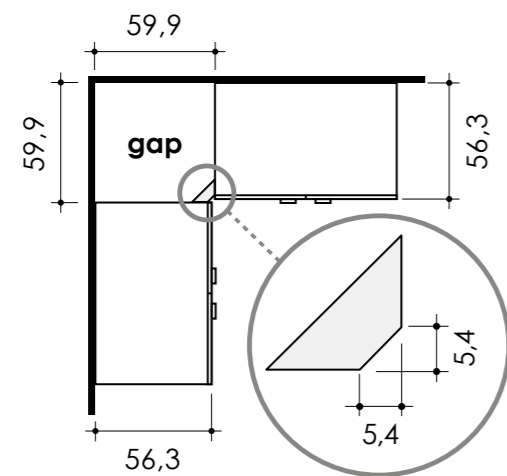

Components in **CARCASE** colors



# End units Dpt 56.3 - W 40

## Ht 193.6

L in drawing

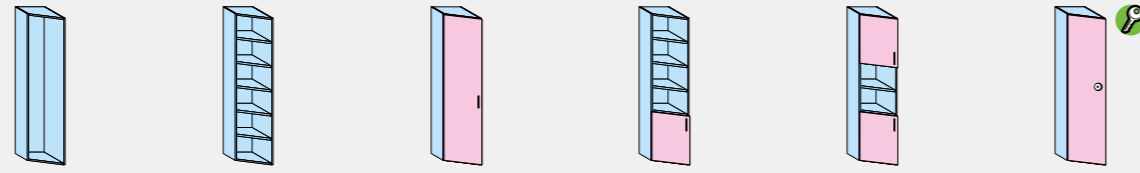

Code	L	PK11.71K	PK11.72R	PK11.73X	PK11.74D	PK11.75L	PK11.76S
	R	PK11.77Y	PK11.78E	PK11.79M	PK11.80H	PK11.81Q	PK11.82W
ONE	matte						
	glossy						
CLUB							
WINDOW							

## Ht 225.6

L in drawing

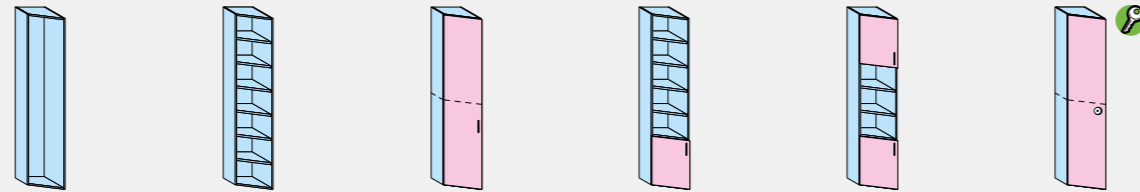

Code	L	PK13.71T	PK13.72Z	PK13.73F	PK13.74N	PK13.75U	PK13.76A
	R	PK13.77G	PK13.78P	PK13.79V	PK13.80S	PK13.81Y	PK13.82E
ONE	matte						
	glossy						
CLUB							
WINDOW							

## Ht 241.6

L in drawing

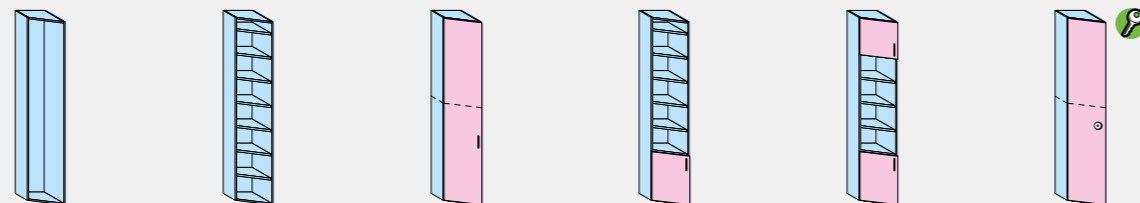

Code	L	PK15.71B	PK15.72H	PK15.73Q	PK15.74W	PK15.75C	PK15.76K
	R	PK15.77R	PK15.78X	PK15.79D	PK15.80A	PK15.81G	PK15.82P
ONE	matte						
	glossy						
CLUB							
WINDOW							

## Ht 257.6

L in drawing

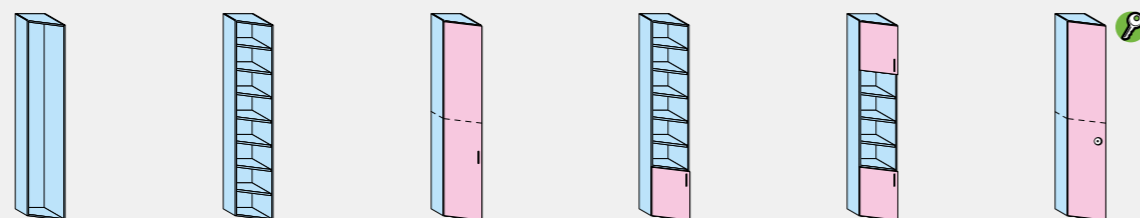

Code	L	PK17.71L	PK17.72S	PK17.73Y	PK17.74E	PK17.75M	PK17.76T
	R	PK17.77Z	PK17.78F	PK17.79N	PK17.80K	PK17.81R	PK17.82X
ONE	matte						
	glossy						
CLUB							
WINDOW							

- Components in **GROUP 2 colors**
- Components in **Types and colors FRONT**
- Element complete with bar lock.

\* Price of the element in GROUP 2 colors (CARCASE colors excluded)

## Ht 289.6

L in drawing

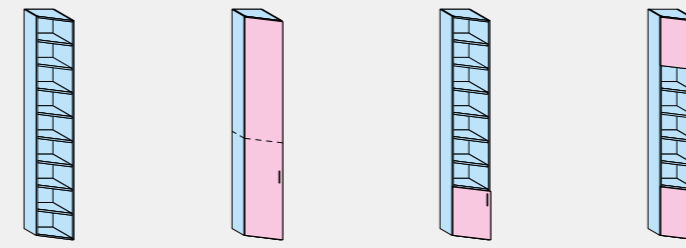

Code	L	PK15.83V	PK15.84B	PK15.85H	PK15.86Q		
	R	PK15.87W	PK15.88C	PK15.89K	PK15.90F		
ONE	matte						
	glossy						
CLUB							
WINDOW							

### Technical information

- They are equipped with adjustable feet.
- The doors are fitted with decelerated hinges.
- It have doors with 30° hinges and specific hinge plates.
- It is not possible to fit the clothes hanging bar.
- Internal fittings supplied consist in: movable shelves every 32 cm in line with the open compartments; 1 movable shelf in line with doors Ht 224 - 240 - 256 - 288.
- **For custom cuts consult the relevant chapter.**

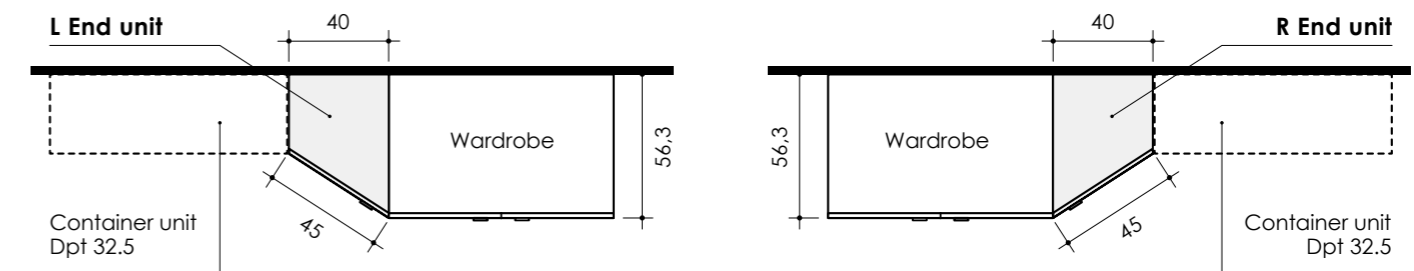

#### Movable shelf for end unit

W 36,3  
Dpt 51,5  
Th 2,5

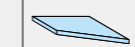

#### Dividing movable shelf for end unit

*Only for use as dividing surface between doors*

W 36,3  
Dpt 53  
Th 2,5



Code	L	PK01.47D	PK01.49S		
	R	PK01.48L	PK01.50P		
*					



- OPTIONAL:** p. 86
- A · Extra colors for Top panel, Bottom panel and Shelves
  - B · Extra colors for Side panels
  - C · Increased Back panel Th 0.8
  - E · Side panels with led lighting



p. 56 Knob and handle positions

# LOGIK end bookshelves

For wardrobes Dpt 56.3

With Container W 30 - Dpt 45

## Ht 193.6

L in drawing

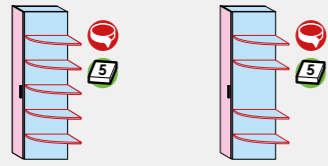

Code	L	PK20.31M	PK20.32T			
	R	PK20.33Z	PK20.34F			
ONE	matte					
	glossy					
CLUB						

## Ht 225.6

L in drawing

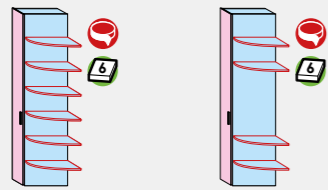

Code	L	PK20.35N	PK20.36U			
	R	PK20.37A	PK20.38G			
ONE	matte					
	glossy					
CLUB						

## Ht 241.6

L in drawing

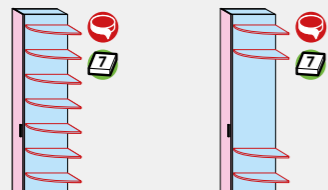

Code	L	PK20.88K	PK20.89R			
	R	PK20.90N	PK20.91U			
ONE	matte					
	glossy					
CLUB						

## Ht 257.6

L in drawing

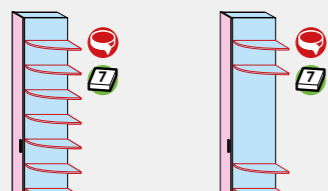

Code	L	PK20.39P	PK20.40L			
	R	PK20.41S	PK20.42Y			
ONE	matte					
	glossy					
CLUB						

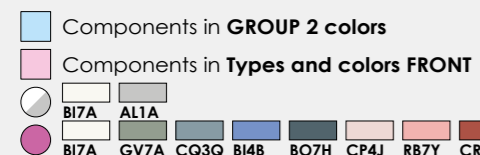

- \* Price of the element in GROUP 2 colors (CARCASE colors excluded)
- Inside shelves: The number indicates the quantity.
- Shaped components available with contrasting edging.

### Technical information

- Fitted with adjustable feet.
- The doors are with decelerated hinges.
- Shaped shelves are always mounted 32 mm apart.
- At least 4 shaped shelves are required to ensure the element's stability.
- For custom cuts consult the relevant chapter.

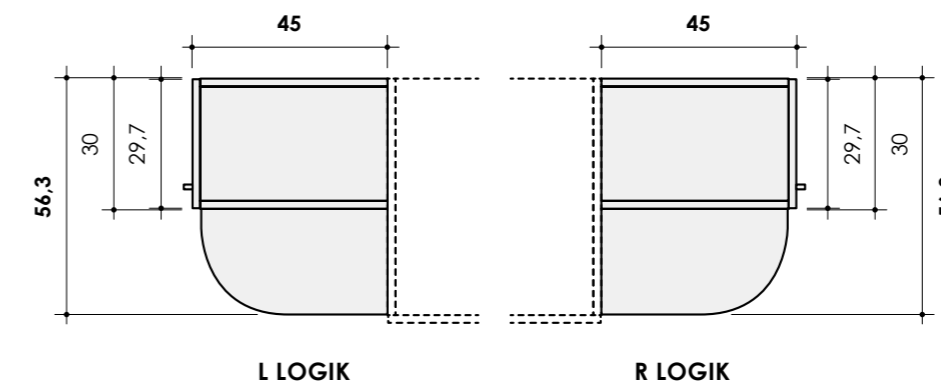

L example

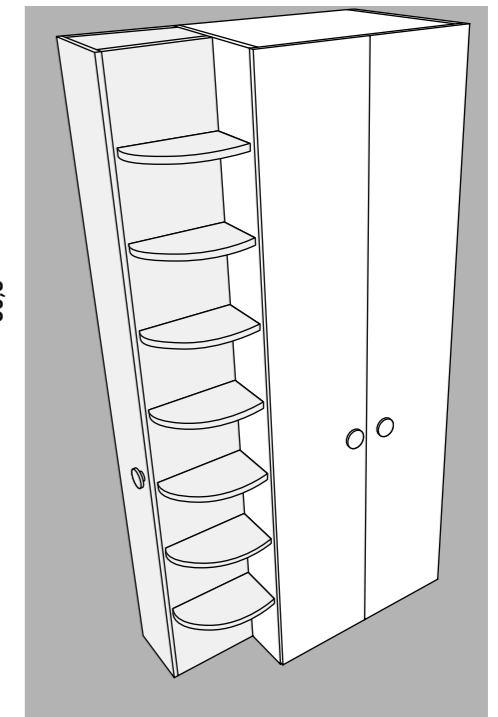

	<b>Movable inner shelf</b> Th 2.5	<b>Shaped shelf</b> Th 2.5	<b>Clothes hooks BOLLINO</b> Dpt 4 Ø 10	<b>Clothes hooks TWIN</b> Ht 12,7 W 3,4 Dpt 5,2	<b>HIP</b> Melamine-coated Ht 29,4 W 18 Dpt 25	<b>Round mirror</b> With biadhesive tape Ø 30
Code	PK01.65B	P99.18M	P40.51A	P71.62V	P01.39E	P99.19S
	*					

- OPTIONAL: p. 86**
- A · Extra colors for Top panel, Bottom panel and Shelves
- B · Extra colors for Side panels
- C · Increased Back panel Th 0.8
- E · Side panels with led lighting

# VELA end bookshelves L 30.7 - Dpt 54

For wardrobes Dpt 56.3

## Ht 193.6

L in drawing

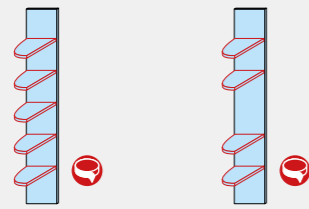

Code	L	PK20.48N	PK20.49U				
	R	PK20.50R	PK20.51X				

## Ht 225.6

L in drawing

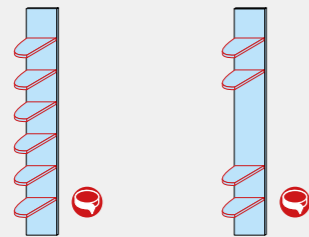

Code	L	PK20.52D	PK20.53L				
	R	PK20.54S	PK20.55Y				

## Ht 241.6

L in drawing

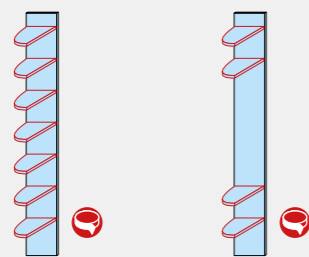

Code	L	PK20.92A	PK20.93G				
	R	PK20.94P	PK20.95V				

## Ht 257.6

L in drawing

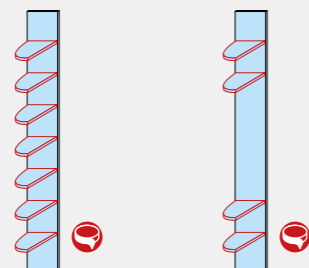

Code	L	PK20.56E	PK20.57M				
	R	PK20.58T	PK20.59Z				

Components in **GROUP 2 colors**

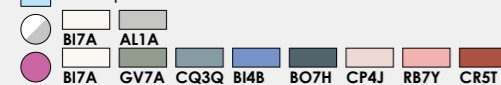

Shaped components available with contrasting edging.

### Technical information

- In addition to the standard CARCASE colors, the rear panel is available in all GROUP 2 colors (with surcharge). Unless otherwise specified, the back panel will have the same colour selected for the coloured trim.
- The shelves are always spaced apart at a distance of 32 cm.
- **At least 4 shaped shelves are required to ensure the element's stability.**
- **For custom cuts consult the relevant chapter.**

+ 50,00 Surcharge for VELA back panels **GROUP 2 colors** (CARCASE colors excluded);

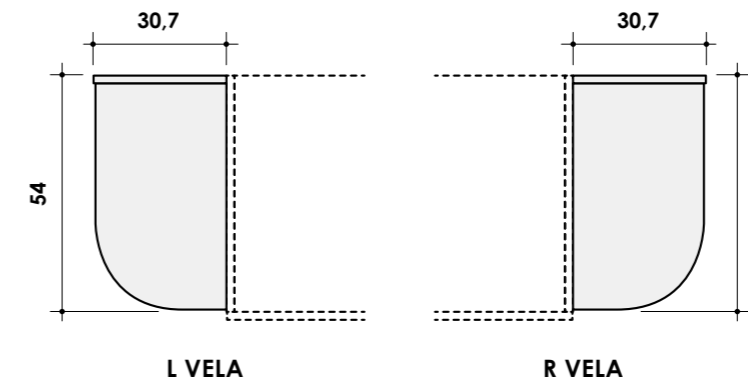

L example

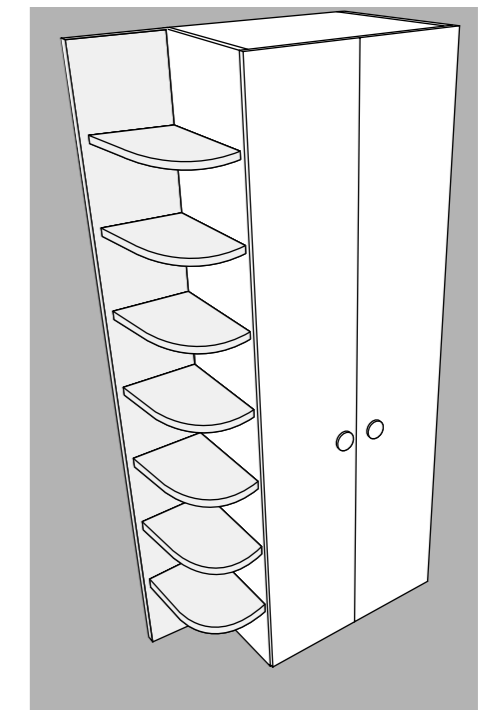

	Shaped shelf	Clothes hooks BOLLINO	Clothes hooks TWIN	HIP Melamine-coated
	Th 2,5	Dpt 4	Ht 12,7	Ht 29,4
		Ø 10	W 3,4	W 18
			Dpt 5,2	Dpt 25
Code	PL36.83H	P40.51A	P71.62V	P01.39E

# QUID end bookshelves

For wardrobes Dpt 56.3

With door W 60

## Ht 193.6

L in drawing

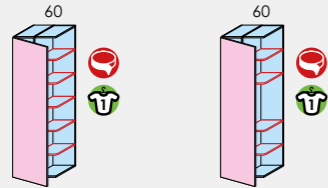

Code	L	PK20.63R	PK20.64X			
	R	PK20.65D	PK20.66L			
ONE	matte					
	glossy					
CLUB						

## Ht 225.6

L in drawing

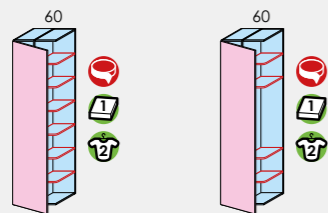

Code	L	PK20.67S	PK20.68Y			
	R	PK20.69E	PK20.70B			
ONE	matte					
	glossy					
CLUB						

## Ht 241.6

L in drawing

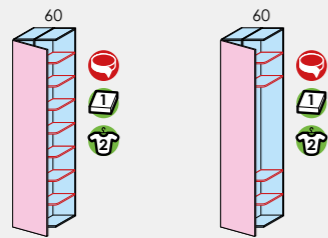

Code	L	PK20.96B	PK20.97H			
	R	PK20.98Q	PK20.99W			
ONE	matte					
	glossy					
CLUB						

## Ht 257.6

L in drawing

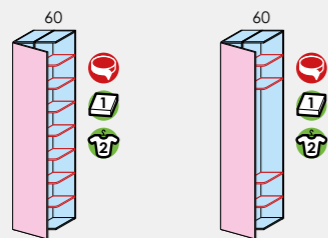

Code	L	PK20.71H	PK20.72Q			
	R	PK20.73W	PK20.74C			
ONE	matte					
	glossy					
CLUB						

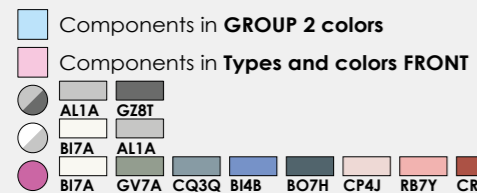

- \* Price of the element in GROUP 2 colors (CARCASE colors excluded)
- Inside shelves: The number indicates the quantity.
- Clothes hanging bars: The number indicates the quantity.
- Shaped components available with contrasting edging.

### Technical information

- Fitted with adjustable feet.
- The door is supplied without a handle and decelerated hinges.
- The shelves are always spaced apart at a distance of 32 cm.
- The bookshelf must be fixed to wardrobe side panel using the provided hardware.
- For custom cuts consult the relevant chapter.
- HIP and HOP cannot be inserted in the upper and lower compartment of the element.

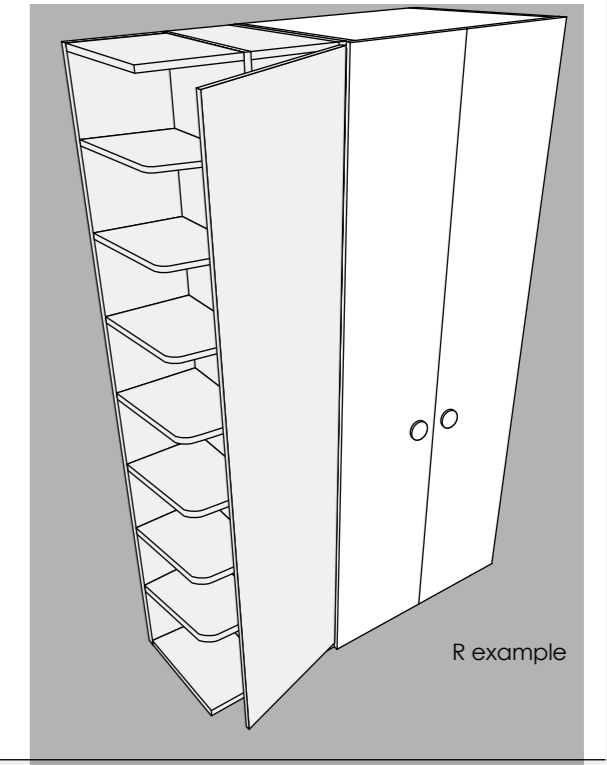
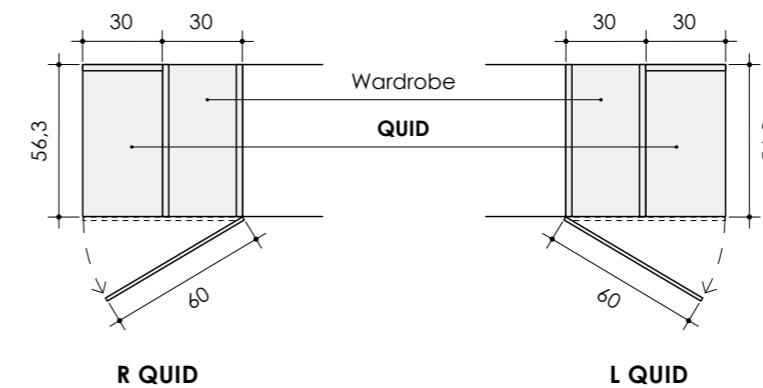

	<b>Dividing movable shelf</b> Th 2,5 	<b>BASIC clothes hanging bar</b> W 26,3 	<b>PLUS clothes hanging bar</b> W 26,3 	<b>Shaped shelf</b> Th 2,5 	<b>Clothes hooks BOLLINO</b> Dpt 4 Ø 10 	<b>Clothes hooks TWIN</b> Ht 12,7 W 3,4 Dpt 5,2 
Code	PK01.05U	P08.00R	PK01.42W	PL36.82B	P40.51A	P71.62V
	*					

	<b>HIP</b> Melamine-coated Ht 29,4 W 18 Dpt 25 	<b>HOP</b> Melamine-coated Ht 29,4 W 30 Dpt 25 	<b>Round mirror</b> With biadhesive tape Ø 30 
Code	P01.39E	P01.40L	P99.19S

- OPTIONAL: p. 86**
- A · Extra colors for Top panel, Bottom panel and Shelves
  - B · Extra colors for Side panels
  - C · Increased Back panel Th 0.8
  - D · PLUS clothes-hanging bar
  - E · Side panels with led lighting

p. 56 Knob and handle positions

# SMART end bookshelves W 54.5 - Dpt 26

For wardrobes Dpt 56.3

	Ht 193.6	Ht 225.6	Ht 241.6	Ht 257.6	
Code	PK20.60W	PK20.61C	PK20.28B	PK20.62K	

	<b>HIP</b> Melamine-coated Ht 29,4 W 18 Dpt 25 	<b>HOP</b> Melamine-coated Ht 29,4 W 30 Dpt 25 			
Code	P01.39E	P01.40L			

## Technical information

- Fitted with adjustable feet.
- They are not fitted with back panels.
- **The bookshelf must be fixed to wardrobe side panel using the provided hardware.**
- The shelves are always spaced apart at a distance of 32 cm.
- **For custom cuts consult the relevant chapter.**
- HIP and HOP cannot be inserted in the upper and lower compartment of the element.

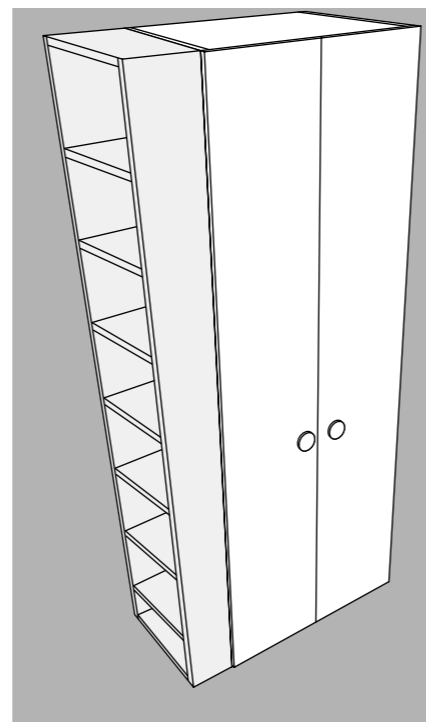
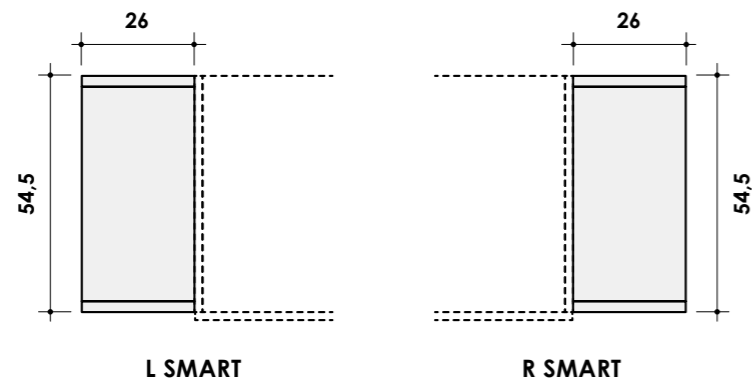

Components in **GROUP 2 colors**  
 B17A AL1A

Shaped components available with contrasting edging.

# SUMMER end bookshelves W 53.9 - Dpt 21

For wardrobes Dpt 56.3

	Ht 159.7 For wardrobe Ht 193.6	Ht 191.7 For wardrobes Ht 225.6 and 241.6	Ht 223.7 For wardrobe Ht 257.6	Ht 64	Ht 96
Code	PK20.43E	PK20.44M	PK20.45T	PK20.46Z	PK20.47F

	<b>Metal uprights</b> Ø 0.6  Ht 159.7 For wardrobe Ht 193.6 For 5 shaped shelves.	Ht 191.7 For wardrobes Ht 225.6 and 241.6 For 6 shaped shelves.	Ht 223.7 For wardrobe Ht 257.6 For 7 shaped shelves.	<b>Shaped shelf complete with holes</b> W 53,9 Dpt 21 Th 2,5 	
Code	P08.46R	P08.47W	P08.48B	P08.49G	

## Technical information

- Shaped shelves are always mounted 32 mm apart.

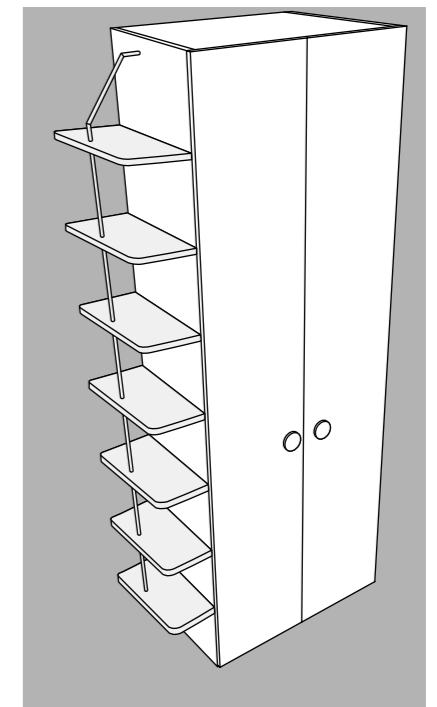
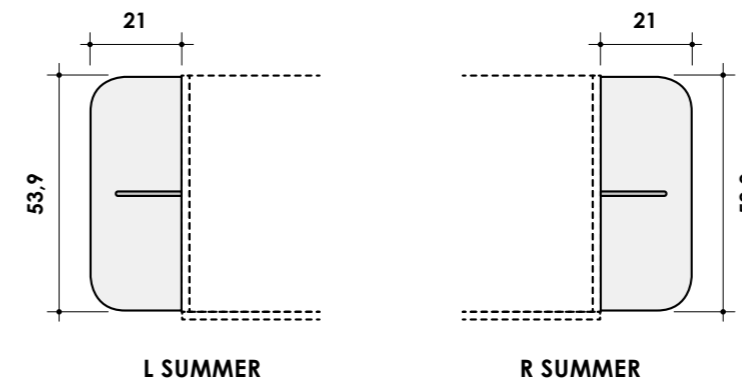

Wardrobes  
hinged doors



# TWIG wardrobes Ht 184.2 - Dpt 56.3

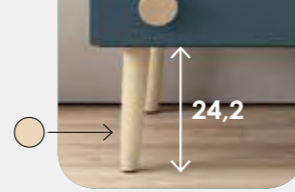

All wardrobes are equipped with increased back panel Th 0.8  
Available with internal shelves indicated by dotted line

## W 45

Specify hinge  
R or L

Reference images →

<b>Code</b>	PK73.00T	PK73.01Z	PK73.02F	PK73.03N	PK73.04U	PK73.05A	PK73.06G		PK73.28F	PK73.29N	PK73.30K	PK73.31R	PK73.32X	PK73.33D						
ONE	matte																			
	glossy																			
CLUB																				
WINDOW																				

## W 60

Specify hinge  
R or L

<b>Code</b>	PK73.07P	PK73.08V	PK73.09B	PK73.10Y	PK73.11E	PK73.12M	PK73.13T		PK73.34L	PK73.35S	PK73.36Y	PK73.37E	PK73.38M	PK73.39T						
ONE	matte																			
	glossy																			
CLUB																				
WINDOW																				

## W 90

Reference images →

<b>Code</b>	PK73.14Z	PK73.15F	PK73.16N	PK73.17U	PK73.18A	PK73.19G	PK73.20D		PK73.40Q	PK73.41W	PK73.42C	PK73.43K	PK73.44R	PK73.45X						
ONE	matte																			
	glossy																			
CLUB																				
WINDOW																				

## W 120

Drawers and big drawers  
CHARM with "Quadro" soft  
rails as standard  
(without surcharges)

<b>Code</b>	PK73.21L	PK73.22S	PK73.23Y	PK73.24E	PK73.25M	PK73.26T	PK73.27Z		PK73.46D	PK73.47L	PK73.48S	PK73.49Y	PK73.50V	PK73.51B						
ONE	matte																			
	glossy																			
CLUB																				
WINDOW																				

- Components in **GROUP 2 colors**
- Components in **Types and colors FRONT**
- Clothes hanging bar

**Solid natural ash wood**  
Wood is a natural product and as such is subject to variations in color and grain. Differences in grain or color therefore do not constitute grounds for dispute.



**OPTIONAL:**  
p. 86

- A · Extra colors for Top panel, Bottom panel and Shelves
- B · Extra colors for Side panels
- D · PLUS clothes-hanging bar
- F · Drawers and big drawers with soft-close

**CLUB**  
drawers and big drawers  
CHARM with soft-close "Quadro"  
type slides as standard  
(without surcharges)

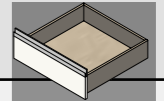

p. 56 Knob and handle positions  
p. 160 Accessories for TWIG wardrobe Dpt 56.3

# TWIG wardrobes Ht 216.2 - Dpt 56.3

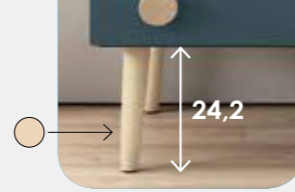

All wardrobes are equipped with increased back panel Th 0.8  
Available with internal shelves indicated by dotted line

## W 45

Specify hinge  
R or L

Reference images →

Code	PK74.00X	PK74.01D	PK74.02L	PK74.03S	PK74.04Y	PK74.05E	PK74.06M		PK74.28L	PK74.29S	PK74.30P	PK74.31V	PK74.32B	PK74.33H					
ONE	matte																		
	glossy																		
CLUB																			
WINDOW																			

## W 60

Specify hinge  
R or L

Code	PK74.07T	PK74.08Z	PK74.09F	PK74.10C	PK74.11K	PK74.12R	PK74.13X		PK74.34Q	PK74.35W	PK74.36C	PK74.37K	PK74.38R	PK74.39X					
ONE	matte																		
	glossy																		
CLUB																			
WINDOW																			

## W 90

Reference images →

Code	PK74.14D	PK74.15L	PK74.16S	PK74.17Y	PK74.18E	PK74.19M	PK74.20H		PK74.40U	PK74.41A	PK74.42G	PK74.43P	PK74.44V	PK74.45B					
ONE	matte																		
	glossy																		
CLUB																			
WINDOW																			

## W 120

Drawers and big drawers  
CHARM with "Quadro" soft  
rails as standard  
(without surcharges)

Code	PK74.21Q	PK74.22W	PK74.23C	PK74.24K	PK74.25R	PK74.26X	PK74.27D		PK74.46H	PK74.47Q	PK74.48W	PK74.49C	PK74.50Z	PK74.51F					
ONE	matte																		
	glossy																		
CLUB																			
WINDOW																			

- Components in **GROUP 2 colors**
- Components in **Types and colors FRONT**
- Clothes hanging bar

**Solid natural ash wood**  
Wood is a natural product and as such is subject to variations in color and grain. Differences in grain or color therefore do not constitute grounds for dispute.



**OPTIONAL:**  
p. 86

- A · Extra colors for Top panel, Bottom panel and Shelves
- B · Extra colors for Side panels
- D · PLUS clothes-hanging bar
- F · Drawers and big drawers with soft-close

**CLUB**  
drawers and big drawers  
CHARM with soft-close "Quadro"  
type slides as standard  
(without surcharges)



p. 56 Knob and handle positions  
p. 160 Accessories for TWIG wardrobe Dpt 56.3

# Accessories for TWIG wardrobe Dpt 56.3

W	Code	Code	Code	Code	Code
45 (41.3)	PK01.01T	PK01.06A	PK01.10S	PK01.13M	PK01.19A
60 (56.3)	PK01.02Z	PK01.07G	PK01.11Y	PK01.14T	PK01.20X
90 (86.3)	PK01.03F	PK01.08P	PK01.12E	PK01.15Z	PK01.21D
120 (116.3)	PK01.04N	PK01.09V	-	-	-

W	Code	Code	Code
45 (41.3)	P50.44Q	P50.79E	PK01.43C
60 (56.3)	P26.48Z	P26.49E	PK01.44K
90 (86.3)	P50.45V	P50.81R	PK01.45R
120 (116.3)	-	P02.57F	PK01.46X

W	Code
45	P77.01H
60	P77.02P
90	P77.03U
105	PK72.16H
120	P93.96R
135	P77.04Z
150	PK72.17Q
165	PK72.18W
180	P77.05E
225	P77.06L
240	PK72.19C
270	P77.07R
Custom-made Max 360 Min 30.1	P77.08W

## W 90

Code	Code	Code	Code	Code	Code
PL04.13B	P02.58M	P07.04K	P07.05Q	P07.07A	P07.08F

Code	Code	Code	Code
P07.08F	P07.10S	P07.12C	P07.13H

W	Code	matte	glossy
45	PK72.46Z		
60	PK72.47F		
90	PK72.48N		
105	PK72.49U		
120	PK72.50R		
135	PK72.51X		
150	PK72.52D		
165	PK72.53L		
180	PK72.54S		
225	PK72.55Y		
240	PK72.56E		
270	PK72.57M		
Custom-made Max 300 (258 for glossy) Min 30.1	PK72.58T		

Code	Code	Code	Code
PL04.17C	P48.58Q	P48.55Y	P30.44L

Code	Code
P07.70T	P08.32Q

W	Code
45	PK77.00L
60	PK77.01S
90	PK77.02Y
105	PK77.03E
120	PK77.04M
135	PK77.05T
150	PK77.06Z
165	PK77.07F
180	PK77.08N
225	PK77.09U
240	PK77.10R
270	PK77.11X
Custom-made Max 300 Min 30.1	PK77.12D

Code	Code	Code	Code	Code
P08.71B	P08.72G	P08.73N	P08.74T	P07.30A

Code	Code	Code
P07.31F	PL86.17N	PL86.18U

- Components in **GROUP 1** colors
- Components in **GROUP 2** colors
- Components in **GROUP 3** colors
- AL1A GZ8T
- BI7A GZ8T

\* Price of the element in GROUP 2 colors (CARCASE colors excluded)

**OPTIONAL:** p. 86 D - PLUS clothes rail (for Wardrobe separator)

p. 56 Knob and handle positions

Wardrobes hinged doors

# Service furniture Dpt 72.3 - technical information

## Technical information

- They are equipped with adjustable feet.
- The doors have soft-close hinges.
- They do not have a bottom panel.
- The service units are proposed in two types: with back panel that stops at the chain a few centimetres off the floor (Example 1) and for washing machines, with a back panel that stops at the upper chain, leaving an empty space at the back to allow the passage of the fill and drain pipes (Example 2).
- Inside, they can accommodate storage accessories Dpt 54.5 (open).
- **For custom cuts, see the relative chapter.**

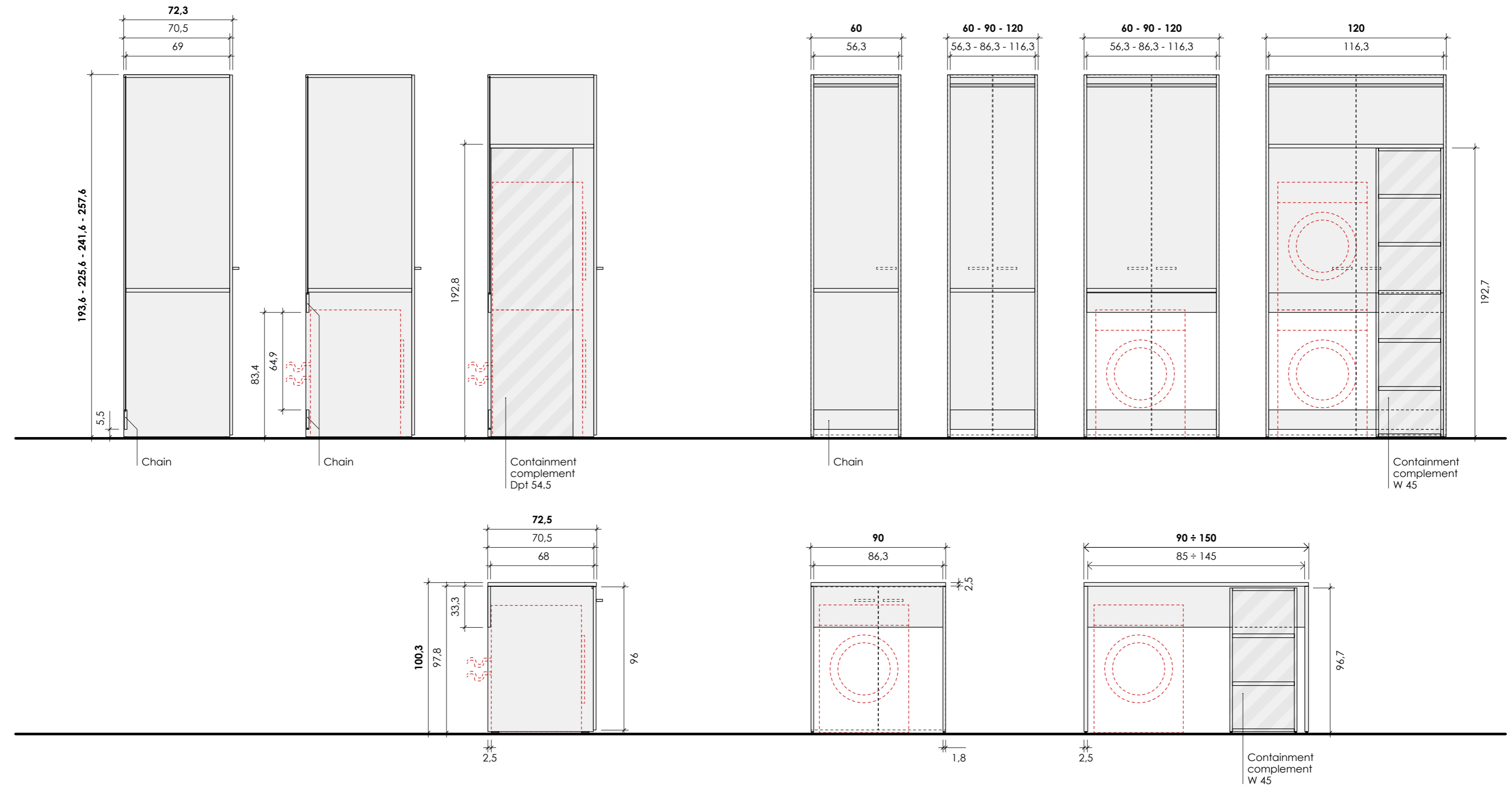

# Service furniture Dpt 72.3

Wardrobes  
hinged doors

## W 60

Specify hinge  
R or L

Reference images →	Ht 193.6				Ht 225.6				Ht 241.6		Ht 257.6	
	<b>Code</b>	<b>PK19.72U</b>	<b>PK19.77H</b>	<b>PK19.82F</b>	<b>PK19.87P</b>	<b>PK19.61P</b>	<b>PK19.62V</b>	<b>PK19.92M</b>	<b>PK19.67U</b>			
	ONE	matte										
	glossy											
CLUB												

## W 60

Reference images →												
	<b>Code</b>	<b>PK19.74P</b>	<b>PK19.75V</b>	<b>PK19.84U</b>	<b>PK19.85A</b>	<b>PK19.63B</b>	<b>PK19.64H</b>	<b>PK19.94Z</b>	<b>PK19.95F</b>			
	ONE	matte										
		glossy										
CLUB												

## W 90

<b>Code</b>	<b>PK19.71A</b>	<b>PK19.76B</b>	<b>PK19.81Z</b>	<b>PK19.86G</b>	<b>PK19.65Q</b>	<b>PK19.66W</b>	<b>PK19.91E</b>	<b>PK19.96N</b>			
ONE	matte										
	glossy										
CLUB											

## W 120

<b>Code</b>	<b>PK19.73G</b>	<b>PK19.78Q</b>	<b>PK19.83N</b>	<b>PK19.88V</b>	<b>PK19.67C</b>	<b>PK19.68K</b>	<b>PK19.93T</b>	<b>PK19.98A</b>			
ONE	matte										
	glossy										
CLUB											

### Work plans Ht 100.3

With doors W 90 	Open W 90 	Open custom W Min 90 Max 150 
------------------------	------------------	-------------------------------------

<b>Code</b>	<b>PK02.10W</b>	<b>PK02.11C</b>	<b>PK02.12K</b>	<b>PK02.14X</b>	<b>PK02.15D</b>	<b>PK02.16L</b>	<b>PK02.13R</b>	<b>PK02.17S</b>	<b>PK02.18Y</b>	<b>PK02.19E</b>
ONE	matte									
	glossy									
CLUB										

### Containment complements W 45 (feet Ht 0.7 included)

With full-length door Ht 96,7 Dpt 56,3 	With 2 drawers and 2 deep drawers Ht 96,7 Dpt 56,3 	With laundry basket Ht 96,7 Dpt 56,3 	Open-plan Ht 96,7 Dpt 54,5 	Ht 128,7 	Ht 160,7 	Ht 192,7 
--	--	--	--------------------------------------	--------------	--------------	--------------

- Components in **CARCASE** colors
- Components in **GROUP 3** colors
- Components in **Types and colors FRONT**

- OPTIONAL:** p. 86
- A · Extra colors for Top panel and Shelves
  - B · Extra colors for Side panels
  - C · Increased Back panel Th 0.8
  - D · PLUS clothes-hanging bar
  - E · Side panels with led lighting
  - F · Drawers and big drawers with soft-close

- p. 44 Filler strips
- p. 56 Knob and handle positions
- p. 166 Accessories for service furniture Dpt 72.3

# Accessories for service furniture Dpt 72.3

W	Code	Code	Code
60 (56.3) *	PK01.98N	PK02.20B	PK02.23W
90 (86.3) *	PK01.99U	PK02.21H	PK02.24C
120 (116.3) *	PK02.00R	PK02.22Q	PK02.25K

W	Code	Code	Code
60 (56.3)	P26.48Z	P26.49E	PK01.44K
90 (86.3)	P50.45V	P50.81R	PK01.45R
120 (116.3)	-	P02.57F	PK01.46X

Code	Code	Code	Code	Code	Code
PL04.17C	P02.58M	P02.59S	P48.55Y	PK02.26R	PK02.27X

**Foldaway ironing board**  
180° rotation. With lock system to fix the ironing board in any position. Includes ball bearing slides for smooth and silent sliding. Minimum internal dimensions of unit necessary for assembly: 45 x 45.

Code	Code	Code	Code	Code	Code
P07.04K	P07.05Q	P07.07A	P07.10S	P30.44L	P07.70T

**BERNARDO**  
Clothes hangers  
Dpt 2  
W 28

**Tray**  
Ht 4  
Dpt 15  
W 25

Code	Code	Code	Code
P08.71B	P08.72G	P07.30A	P07.31F

Components in **GROUP 3 colors** \* Price of the element in GROUP 3 colors (CARCASE colors excluded)

AL1A GZ8T

Wardrobes hinged doors



GROUP 1 colors	Rovere Dorian <b>RD5T</b>	Rovere white <b>RW3Q</b>	Noce naturale <b>NN7H</b>	Eucalipto <b>CL1X</b>	Domy <b>DM7P</b>	Bianco UV <b>BU3Q</b>
	Ciliegio bianco <b>CB6K</b>	Malta <b>ML7H</b>	Feltro <b>FL8X</b>	Cemento Masdar <b>CM3Q</b>	Blu indaco <b>BI4B</b>	
	Noce <b>NC4B</b>	Desert <b>DS9L</b>	Canapa <b>CN1X</b>	Moka <b>MK6B</b>	Cipria <b>CP4J</b>	
	Bianco opaco <b>BI7A</b>	Grigio Dorian <b>GL4R</b>	Basalto <b>BS5T</b>	Grigio titanio <b>GZ8T</b>	Rosa bubble <b>RB7Y</b>	
	Agave <b>GV7A</b>	Verde Alpi <b>VA5T</b>	Cadaques <b>CQ3Q</b>	Giallo zafferano <b>GZ8A</b>		
	Blu opale <b>BO7H</b>			Corallo <b>CR5T</b>		

Types and colors FRONT	ONE	<table border="1"> <tr> <td>Rovere white <b>RW3Q</b></td> <td>Rovere Dorian <b>RD5T</b></td> <td>Ciliegio bianco <b>CB6K</b></td> <td>Noce naturale <b>NN7H</b></td> <td>Noce <b>NC4B</b></td> <td>Eucalipto <b>CL1X</b></td> <td>Malta <b>ML7H</b></td> </tr> <tr> <td>Feltro <b>FL8X</b></td> <td>Cemento Masdar <b>CM3Q</b></td> <td>Bianco opaco <b>BI7A</b></td> <td>Desert <b>DS9L</b></td> <td>Canapa <b>CN1X</b></td> <td>Moka <b>MK6B</b></td> <td>Grigio Dorian <b>GL4R</b></td> </tr> <tr> <td>Basalto <b>BS5T</b></td> <td>Grigio titanio <b>GZ8T</b></td> <td>Domy <b>DM7P</b></td> <td>Agave <b>GV7A</b></td> <td>Verde Alpi <b>VA5T</b></td> <td>Cadaques <b>CQ3Q</b></td> <td>Blu indaco <b>BI4B</b></td> </tr> <tr> <td>Blu opale <b>BO7H</b></td> <td>Cipria <b>CP4J</b></td> <td>Rosa bubble <b>RB7Y</b></td> <td>Giallo zafferano <b>GZ8A</b></td> <td>Corallo <b>CR5T</b></td> <td></td> <td></td> </tr> </table>							Rovere white <b>RW3Q</b>	Rovere Dorian <b>RD5T</b>	Ciliegio bianco <b>CB6K</b>	Noce naturale <b>NN7H</b>	Noce <b>NC4B</b>	Eucalipto <b>CL1X</b>	Malta <b>ML7H</b>	Feltro <b>FL8X</b>	Cemento Masdar <b>CM3Q</b>	Bianco opaco <b>BI7A</b>	Desert <b>DS9L</b>	Canapa <b>CN1X</b>	Moka <b>MK6B</b>	Grigio Dorian <b>GL4R</b>	Basalto <b>BS5T</b>	Grigio titanio <b>GZ8T</b>	Domy <b>DM7P</b>	Agave <b>GV7A</b>	Verde Alpi <b>VA5T</b>	Cadaques <b>CQ3Q</b>	Blu indaco <b>BI4B</b>	Blu opale <b>BO7H</b>	Cipria <b>CP4J</b>	Rosa bubble <b>RB7Y</b>	Giallo zafferano <b>GZ8A</b>	Corallo <b>CR5T</b>		
		Rovere white <b>RW3Q</b>	Rovere Dorian <b>RD5T</b>	Ciliegio bianco <b>CB6K</b>	Noce naturale <b>NN7H</b>	Noce <b>NC4B</b>	Eucalipto <b>CL1X</b>	Malta <b>ML7H</b>																												
Feltro <b>FL8X</b>	Cemento Masdar <b>CM3Q</b>	Bianco opaco <b>BI7A</b>	Desert <b>DS9L</b>	Canapa <b>CN1X</b>	Moka <b>MK6B</b>	Grigio Dorian <b>GL4R</b>																														
Basalto <b>BS5T</b>	Grigio titanio <b>GZ8T</b>	Domy <b>DM7P</b>	Agave <b>GV7A</b>	Verde Alpi <b>VA5T</b>	Cadaques <b>CQ3Q</b>	Blu indaco <b>BI4B</b>																														
Blu opale <b>BO7H</b>	Cipria <b>CP4J</b>	Rosa bubble <b>RB7Y</b>	Giallo zafferano <b>GZ8A</b>	Corallo <b>CR5T</b>																																
matte																																				
glossy																																				
		<table border="1"> <tr> <td>Rovere white <b>RW3Q</b></td> <td>Rovere Dorian <b>RD5T</b></td> <td>Ciliegio bianco <b>CB6K</b></td> <td>Noce naturale <b>NN7H</b></td> <td>Noce <b>NC4B</b></td> <td>Eucalipto <b>CL1X</b></td> <td>Malta <b>ML7H</b></td> </tr> <tr> <td>Feltro <b>FL8X</b></td> <td>Cemento Masdar <b>CM3Q</b></td> <td>Bianco opaco <b>BI7A</b></td> <td>Desert <b>DS9L</b></td> <td>Canapa <b>CN1X</b></td> <td>Moka <b>MK6B</b></td> <td>Grigio Dorian <b>GL4R</b></td> </tr> <tr> <td>Basalto <b>BS5T</b></td> <td>Grigio titanio <b>GZ8T</b></td> <td>Domy <b>DM7P</b></td> <td>Agave <b>GV7A</b></td> <td>Verde Alpi <b>VA5T</b></td> <td>Cadaques <b>CQ3Q</b></td> <td>Blu indaco <b>BI4B</b></td> </tr> <tr> <td>Blu opale <b>BO7H</b></td> <td>Cipria <b>CP4J</b></td> <td>Rosa bubble <b>RB7Y</b></td> <td>Giallo zafferano <b>GZ8A</b></td> <td>Corallo <b>CR5T</b></td> <td></td> <td></td> </tr> </table>							Rovere white <b>RW3Q</b>	Rovere Dorian <b>RD5T</b>	Ciliegio bianco <b>CB6K</b>	Noce naturale <b>NN7H</b>	Noce <b>NC4B</b>	Eucalipto <b>CL1X</b>	Malta <b>ML7H</b>	Feltro <b>FL8X</b>	Cemento Masdar <b>CM3Q</b>	Bianco opaco <b>BI7A</b>	Desert <b>DS9L</b>	Canapa <b>CN1X</b>	Moka <b>MK6B</b>	Grigio Dorian <b>GL4R</b>	Basalto <b>BS5T</b>	Grigio titanio <b>GZ8T</b>	Domy <b>DM7P</b>	Agave <b>GV7A</b>	Verde Alpi <b>VA5T</b>	Cadaques <b>CQ3Q</b>	Blu indaco <b>BI4B</b>	Blu opale <b>BO7H</b>	Cipria <b>CP4J</b>	Rosa bubble <b>RB7Y</b>	Giallo zafferano <b>GZ8A</b>	Corallo <b>CR5T</b>		
Rovere white <b>RW3Q</b>	Rovere Dorian <b>RD5T</b>	Ciliegio bianco <b>CB6K</b>	Noce naturale <b>NN7H</b>	Noce <b>NC4B</b>	Eucalipto <b>CL1X</b>	Malta <b>ML7H</b>																														
Feltro <b>FL8X</b>	Cemento Masdar <b>CM3Q</b>	Bianco opaco <b>BI7A</b>	Desert <b>DS9L</b>	Canapa <b>CN1X</b>	Moka <b>MK6B</b>	Grigio Dorian <b>GL4R</b>																														
Basalto <b>BS5T</b>	Grigio titanio <b>GZ8T</b>	Domy <b>DM7P</b>	Agave <b>GV7A</b>	Verde Alpi <b>VA5T</b>	Cadaques <b>CQ3Q</b>	Blu indaco <b>BI4B</b>																														
Blu opale <b>BO7H</b>	Cipria <b>CP4J</b>	Rosa bubble <b>RB7Y</b>	Giallo zafferano <b>GZ8A</b>	Corallo <b>CR5T</b>																																
		<p>Specify the color of the CLUB handle</p> <table border="1"> <tr> <td>Bianco opaco <b>BI7A</b></td> <td>Desert <b>DS9L</b></td> <td>Canapa <b>CN1X</b></td> <td>Moka <b>MK6B</b></td> <td>Grigio Dorian <b>GL4R</b></td> <td>Basalto <b>BS5T</b></td> <td>Grigio titanio <b>GZ8T</b></td> </tr> <tr> <td>Domy <b>DM7P</b></td> <td>Agave <b>GV7A</b></td> <td>Verde Alpi <b>VA5T</b></td> <td>Cadaques <b>CQ3Q</b></td> <td>Blu indaco <b>BI4B</b></td> <td>Blu opale <b>BO7H</b></td> <td>Cipria <b>CP4J</b></td> </tr> <tr> <td>Rosa bubble <b>RB7Y</b></td> <td>Giallo zafferano <b>GZ8A</b></td> <td>Corallo <b>CR5T</b></td> <td></td> <td></td> <td></td> <td></td> </tr> </table>							Bianco opaco <b>BI7A</b>	Desert <b>DS9L</b>	Canapa <b>CN1X</b>	Moka <b>MK6B</b>	Grigio Dorian <b>GL4R</b>	Basalto <b>BS5T</b>	Grigio titanio <b>GZ8T</b>	Domy <b>DM7P</b>	Agave <b>GV7A</b>	Verde Alpi <b>VA5T</b>	Cadaques <b>CQ3Q</b>	Blu indaco <b>BI4B</b>	Blu opale <b>BO7H</b>	Cipria <b>CP4J</b>	Rosa bubble <b>RB7Y</b>	Giallo zafferano <b>GZ8A</b>	Corallo <b>CR5T</b>											
Bianco opaco <b>BI7A</b>	Desert <b>DS9L</b>	Canapa <b>CN1X</b>	Moka <b>MK6B</b>	Grigio Dorian <b>GL4R</b>	Basalto <b>BS5T</b>	Grigio titanio <b>GZ8T</b>																														
Domy <b>DM7P</b>	Agave <b>GV7A</b>	Verde Alpi <b>VA5T</b>	Cadaques <b>CQ3Q</b>	Blu indaco <b>BI4B</b>	Blu opale <b>BO7H</b>	Cipria <b>CP4J</b>																														
Rosa bubble <b>RB7Y</b>	Giallo zafferano <b>GZ8A</b>	Corallo <b>CR5T</b>																																		
		<table border="1"> <tr> <td>Trasparente <b>TR9M</b></td> <td>Trasparente fumé <b>FT8P</b></td> <td>Stop-sol <b>ST6P</b></td> <td>Specchio <b>SP7L</b></td> <td></td> <td></td> <td></td> </tr> </table>							Trasparente <b>TR9M</b>	Trasparente fumé <b>FT8P</b>	Stop-sol <b>ST6P</b>	Specchio <b>SP7L</b>																								
Trasparente <b>TR9M</b>	Trasparente fumé <b>FT8P</b>	Stop-sol <b>ST6P</b>	Specchio <b>SP7L</b>																																	
		<p>Specify the color of the aluminum frame</p> <table border="1"> <tr> <td>Alluminio <b>AL1A</b></td> <td>Titan grey <b>TG7H</b></td> <td></td> <td></td> <td></td> <td></td> <td></td> </tr> </table>							Alluminio <b>AL1A</b>	Titan grey <b>TG7H</b>																										
Alluminio <b>AL1A</b>	Titan grey <b>TG7H</b>																																			

Container units hinged doors

Container units - technical information	170
OPTIONAL for Container units	172
Container units Ht 193.6 - Dpt 45	174
Container units Ht 225.6 - Dpt 45	176
Container units Ht 257.6 - Dpt 45	179
Filler strip 5.4 - 5.4 (for empty comers)	182
SMART end bookshelf W 43.2 - Dpt 26	183
Accessories for Container units Dpt 45	184
End units Dpt 45 - W 45	186
Container units Ht 193.6 - Dpt 32.5	188
Container units Ht 225.6 - Dpt 32.5	190
Container units Ht 257.6 - Dpt 32.5	192
Accessories for Container units Dpt 32.5	194

# Container units - technical information

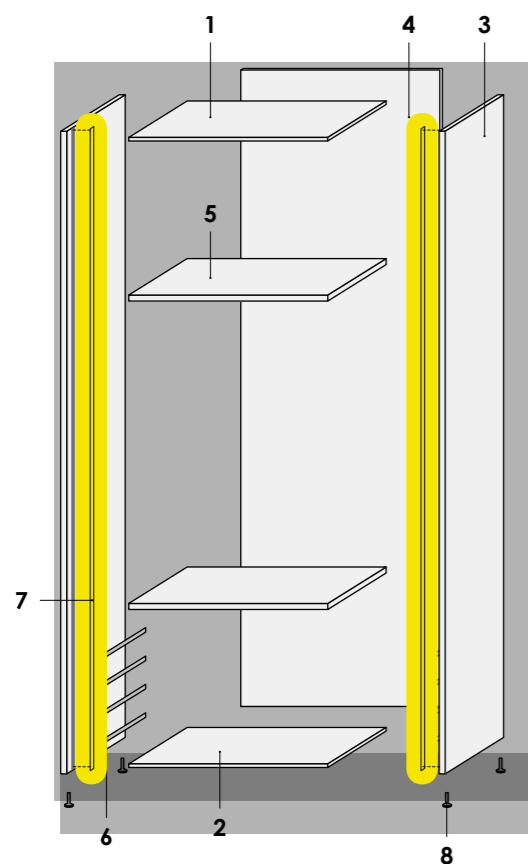

Components:

- 1 Top panel Th 1.8 - With eccentric pin system
- 2 Bottom panel Th 1.8 - With eccentric pin system
- 3 Side panels Th 1.8 - With prefitted hardware.
- 4 Back panel Th 0.3 or 0.8 (optional) - Fitting into shaped connection.
- 5 Movable shelf Th 2.5 - On runner.
- 6 Metal drawer runners
- 7 Strip led (optional) - In full height milled groove.
- 8 Adjustable middle-support feet

Dimensions:

- W 30 - 45 - 60 - 90 - 120  
 Dpt 45 - 32,5  
 Ht 193,6 - 225,6 - 257,6

- Shelves, top and bottom panels in carcass colours.
- These structures can only be placed on the ground.
- The side panels are flush with the top and bottom and have custom holes.
- The hardware is placed in a personalized fashion according to the position of the components.
- Tops are not finished.
- They are equipped with adjustable feet.

### IMPORTANT!

- The doors are fitted with decelerated hinges.
- The drawers and big drawer CLUB (all widths) and the drawers and big drawer W 120 are always fitted with height-adjustable, soft-close, "Quadro" type, metal slides with interior CHARM finish.
- **Internal fittings supplied with the Modular units Dpt 45** consist in melamine-coated inner movable shelves every 32 cm in line with open compartments; Modular units with doors Ht 224 - 256 are complete with 1 movable shelf.
- **Internal fittings supplied with the modular units Dpt 32.5** consist in melamine-coated inner movable shelves every 32 cm.
- **For custom cuts consult the relevant chapter.**
- In mixed compositions, the handles of the WINDOW doors are not aligned (see example).
- In units W 90 with doors W 30 + W 60 the direction is determined by the position of the door W 60 on the ground.
- Upon request, the doors can be supplied without a handle and without handle holes (not on CLUB and WINDOW).
- The Units with pairs of CLUB doors are provided with only one handle. In elements with doors W 30 + 60 the handle is placed on the W 60 door. Upon customer's request the CLUB handle can be mounted on both doors.
- In units Ht 193.6 - 225.6 - 257.6, with transparent glass shelves, an excessive load on the shelves could cause the side panels to warp; it is recommended not to overload them or to insert at least one melamine-coated shelf.

Example of combined composition

**NO**

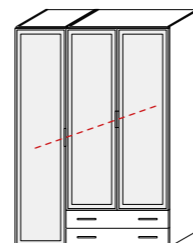

### MODULARITY

- Since this is a container structure each element is complete with 2 side panels, the composition is assembled by fixing the various elements together.
- The fronts are always fit flush, so the side panels are covered by the doors or drawers.
- The overall size of the composition is therefore the sum of the individual fronts.

Ht 257.6

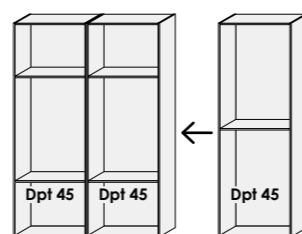

#### Example A

Possible combinations of Container units with the same height and depth.

Ht 257.6

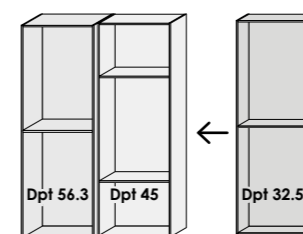

#### Example B

Possible combinations of Wardrobes and Container units with the same height and different depths.

Ht 257.6

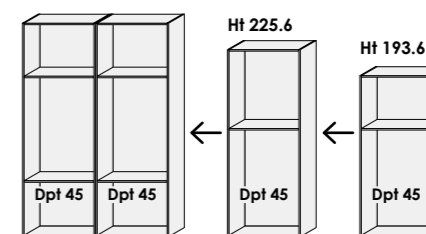

#### Example C

Possible combinations of Container units with different heights and the same depth.

60



75



90

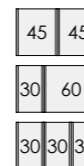

105

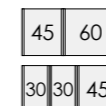

120

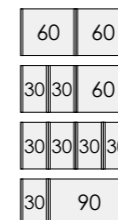

135

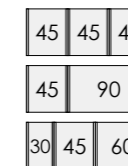

150

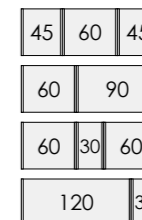

165

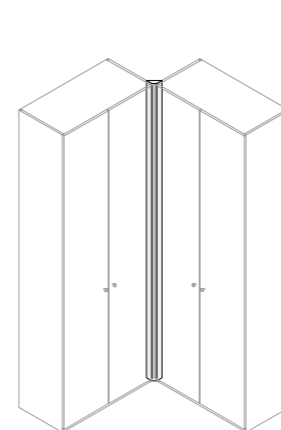
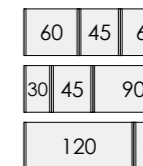

Corner obtained with Filler strip

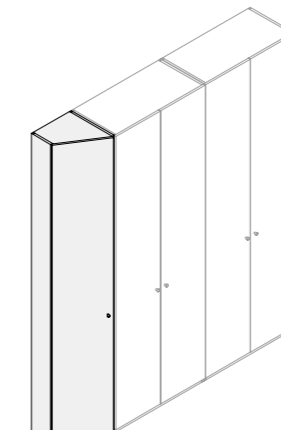

End unit Dpt 45

For technical details see the relevant chapters.

# OPTIONAL for Container units

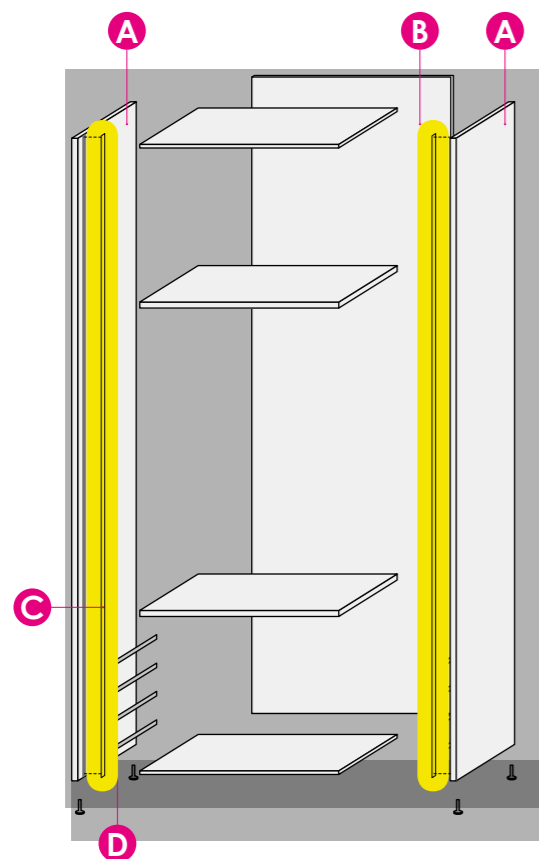

## A Extra colors for Side panels

In addition to the standard CARCASE colors, the side panels are available in all the GROUP 2 colors with surcharge (see table).

• **When placing the order:** indicate the colour in the COLOURED FINISHES variant in Metron 4: all side panels will automatically be delivered in that colour (if specified, 1, 2 or more side panels can be coloured as preferred).

• **N.B.** The surcharge is applied to each single side panel except for the END ELEMENTS, for which the choice of colour and surcharge refers to both side panels of the element.

Side panel	Surcharge for single element (CARCASE colors excluded)	
	Dpt 45	Dpt 32,5
Ht 193,6		
Ht 225,6		
Ht 257,6		
Pair of side panels for End units	Ht 193,6 Ht 225,6 Ht 257,6	-

## B Increased Back panel Th 0.8

On request the Container can be equipped with back panel Th 0.8 with surcharge (see table), in replacement of the standard back panel Th 0.3: unlike the standard one (in the CARCASE colors), the increased back panel is available in all GROUP 2 colors.

• **When placing the order:** indicate YES for increased back panel in the BACK PANEL TYPE variant and the colour in the BACK PANEL COLOUR variant in Metron 4: all back panels will automatically be supplied in the same type and colour (if specified, it is possible to change the back panel type and colour of the various elements as preferred).

• **N.B.** The surcharge is applied to each back panel.

Back panel Th 0.8	Surcharge for single element	
	Ht 193,6 - 225,6 - 257,6	
W 30		
W 40*		
W 45		
W 60		
W 90		
W 120		

\* Back panel for End units

## C Side panels with led lighting

On request the side panels can be equipped with led lighting, with surcharge (see table). Lighting consists in a full-height led strip inset into the side panel.

• **When placing the order:** indicate LIGHT RH SIDE, LIGHT LH SIDE or LIGHT ON BOTH SIDES in the SIDE PANEL LIGHTING variant in Metron 4.

• **N.B.** In End elements the lighting can only be inserted on the side panel Dpt 45.



Led side panel	Surcharge			
	1 side panel	2 side panels	1 side panel	2 side panels
	1 led strip + 1 sensor + 1 power supply	2 led strips + 1 sensor + 1 power supply	1 led strip + 2 sensors + 1 power supply	2 led strips + 2 sensors + 1 power supply
Ht 193,6				
Ht 225,6				
Ht 257,6				

\* For Container units with divided doors

## D Drawers and big drawers with soft-close

On request drawers and big drawers in the "standard" version can be equipped with soft-close mechanisms, with surcharge (see table). Alternatively, drawers and big drawers can be ordered in the CHARM version, with surcharge (see table), equipped with soft-close height-adjustable "Quadro" type runners with prestigious internal finish.

• **When placing the order:** indicate the type of runners in the RUNNER TYPE variant in Metron 4.

• **N.B.** The W 120 drawers and big drawers, and CLUB drawers and big drawers (all widths) with soft-close "Quadro" type runners are supplied standard in the CHARM version (without surcharge).

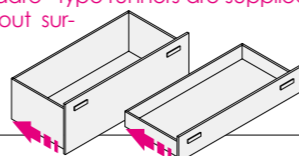

Slow closing	Surcharge for single element
Drawers W 45 - 60 - 90	
Big drawers W 45 - 60 - 90	
CHARM Drawers/Big drawers with soft-close "Quadro" type runners W 45 - 60 - 90	

# Container units Ht 193.6 - Dpt 45

Reference images →

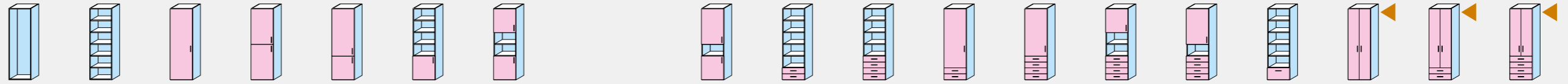

## W 30

Specify hinge R or L

Code	PK30.00S	PK30.01Y	PK30.02E	PK30.03M	PK30.04T	PK30.05Z	PK30.06F		PK30.07N	-	-	-	-	-	-	-	-	-	-
ONE	matte																		
	glossy																		
CLUB																			
WINDOW																			

## W 45

Specify hinge R or L

Code	PK30.08U	PK30.09A	PK30.10X	PK30.11D	PK30.12L	PK30.13S	PK30.14Y		PK30.15E	PK30.16M	PK30.17T	PK30.18Z	PK30.19F	PK30.20C	PK30.21K	PK30.22R	-	-	-	
ONE	matte																			
	glossy																			
CLUB																				
WINDOW																				

## W 60

Specify hinge R or L

Code	PK30.23X	PK30.24D	PK30.25L	PK30.26S	PK30.27Y	PK30.28E	PK30.29M		PK30.30H	PK30.31Q	PK30.32W	PK30.33C	PK30.34K	PK30.35R	PK30.36X	PK30.37D	PK30.38L	PK30.39S	PK30.40P	
ONE	matte																			
	glossy																			
CLUB																				
WINDOW																				

Reference images →

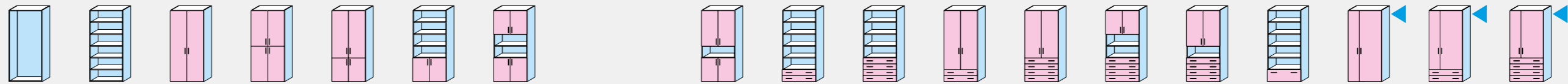

## W 90

Code	PK30.41V	PK30.42B	PK30.43H	PK30.44Q	PK30.45W	PK30.46C	PK30.47K		PK30.48R	PK30.49X	PK30.50U	PK30.51A	PK30.52G	PK30.53P	PK30.54V	PK30.55B	PK30.56H	PK30.57Q	PK30.58W
ONE	matte																		
	glossy																		
CLUB																			
WINDOW																			

## W 120

Drawers and big drawers CHARM with "Quadro" soft rails as standard (without surcharges)

Code	PK30.59C	PK30.60Z	PK30.61F	PK30.62N	PK30.63U	PK30.64A	PK30.65G		PK30.66P	PK30.67V	PK30.68B	PK30.69H	PK30.70E	PK30.71M	PK30.72T	PK30.73Z	-	-	-
ONE	matte																		
	glossy																		
CLUB																			
WINDOW																			

- Components in **CARCASE** colors
- Components in **GROUP 2** colors
- Components in **Types and colors FRONT**

- ▼ With doors W 30
- ▼ With doors W 30 + W 60 - Indicate R or L (drawing - R)



**OPTIONAL:** p. 172

- A · Extra colors for Side panels
- B · Increased Back panel Th 0.8
- C · Side panels with led lighting
- D · Drawers and big drawers with soft-close

**CLUB**

drawers and big drawers CHARM with soft-close "Quadro" type slides as standard (without surcharges)



p. 44 Filler strips  
p. 56 Knob and handle positions  
p. 184 Accessories for Container units Dpt 45

# Container units Ht 225.6 - Dpt 45

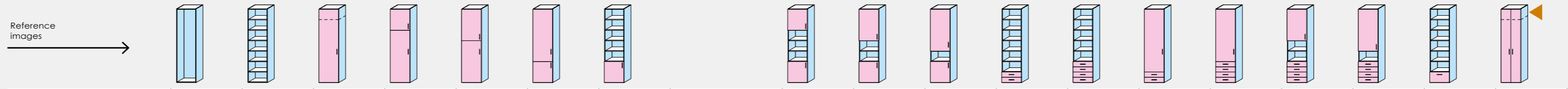

## W 30

Specify hinge  
R or L

Code	PK31.00W	PK31.01C	PK31.02K	PK31.03R	PK31.04X	PK31.05D	PK31.06L		PK31.07S	PK31.08Y	PK31.09E	-	-	-	-	-	-	-	-
ONE	matte																		
	glossy																		
CLUB																			
WINDOW																			

## W 45

Specify hinge  
R or L

Code	PK31.10B	PK31.11H	PK31.12Q	PK31.13W	PK31.14C	PK31.15K	PK31.16R		PK31.17X	PK31.18D	PK31.19L	PK31.20G	PK31.21P	PK31.22V	PK31.23B	PK31.24H	PK31.25Q	PK31.26W	-
ONE	matte																		
	glossy																		
CLUB																			
WINDOW																			

## W 60

Specify hinge  
R or L

Code	PK31.27C	PK31.28K	PK31.29R	PK31.30N	PK31.31U	PK31.32A	PK31.33G		PK31.34P	PK31.35V	PK31.36B	PK31.37H	PK31.38Q	PK31.39W	PK31.40T	PK31.41Z	PK31.42F	PK31.43N	PK31.44U
ONE	matte																		
	glossy																		
CLUB																			
WINDOW																			

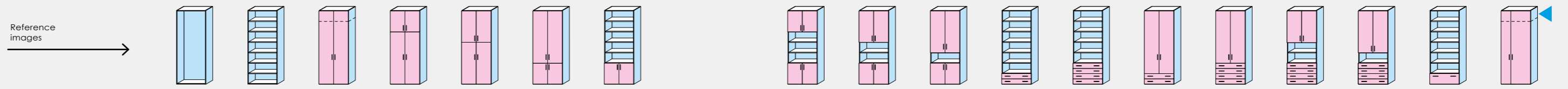

## W 90

Code	PK31.47P	PK31.48V	PK31.49B	PK31.50Y	PK31.51E	PK31.52M	PK31.53T		PK31.54Z	PK31.55F	PK31.56N	PK31.57U	PK31.58A	PK31.59G	PK31.60D	PK31.61L	PK31.62S	PK31.63Y	PK31.64E
ONE	matte																		
	glossy																		
CLUB																			
WINDOW																			

## W 120

Drawers and big drawers  
CHARM with "Quadro" soft  
rails as standard  
(without surcharges)

Code	PK31.67Z	PK31.68F	PK31.69N	PK31.70K	PK31.71R	PK31.72X	PK31.73D		PK31.74L	PK31.75S	PK31.76Y	PK31.77E	PK31.78M	PK31.79T	PK31.80Q	PK31.81W	PK31.82C	PK31.83K	-
ONE	matte																		
	glossy																		
CLUB																			
WINDOW																			

- Components in **CARCASE** colors
- Components in **GROUP 2** colors
- Components in **Types and colors FRONT**

- With doors **W 30**
- With doors **W 30 + W 60** - Indicate R or L (drawing - R)



- OPTIONAL:**  
p. 172
- A · Extra colors for Side panels
  - B · Increased Back panel Th 0.8
  - C · Side panels with led lighting
  - D · Drawers and big drawers with soft-close

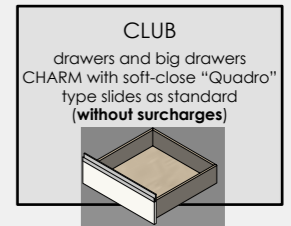

- p. 44 Filler strips
- p. 56 Knob and handle positions
- p. 184 Accessories for Container units Dpt 45

# Container units Ht 225.6 - Dpt 45

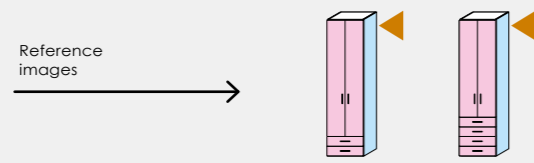

## W 30

Specify hinge  
R or L

Code		-	-				
ONE	matte	-	-				
	glossy	-	-				
CLUB		-	-				
WINDOW		-	-				

## W 45

Specify hinge  
R or L

Code		-	-				
ONE	matte	-	-				
	glossy	-	-				
CLUB		-	-				
WINDOW		-	-				

## W 60

Specify hinge  
R or L

Code		PK31.45A	PK31.46G				
ONE	matte						
	glossy						
CLUB							
WINDOW							

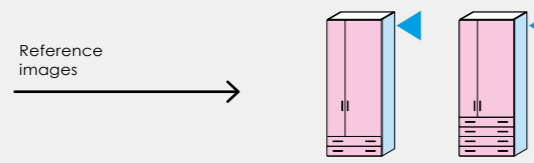

## W 90

Code		PK31.65M	PK31.66T				
ONE	matte						
	glossy						
CLUB							
WINDOW							

## W 120

Drawers and big drawers  
CHARM with "Quadro" soft  
rails as standard  
(without surcharges)

Code		-	-				
ONE	matte	-	-				
	glossy	-	-				
CLUB		-	-				
WINDOW		-	-				

- Components in **CARCASE** colors
- Components in **GROUP 2** colors
- Components in **Types and colors FRONT**

- ▼ With doors W 30
- ▼ With doors W 30 + W 60 - Indicate R or L (drawing - R)

# Container units Ht 257.6 - Dpt 45

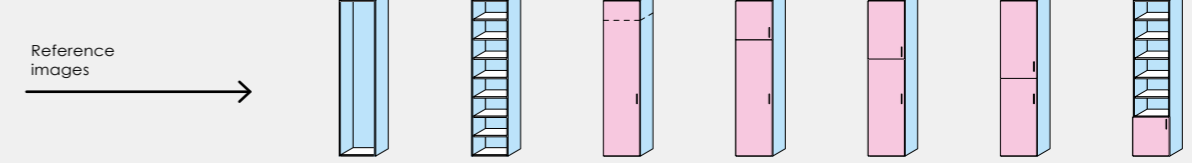

## W 30

Specify hinge  
R or L

Code		PK32.00A	PK32.01G	PK32.02P	PK32.03V	PK32.04B	PK32.05H	PK32.06Q
ONE	matte							
	glossy							
CLUB								
WINDOW								

## W 45

Specify hinge  
R or L

Code		PK32.11N	PK32.12U	PK32.13A	PK32.14G	PK32.15P	PK32.16V	PK32.17B
ONE	matte							
	glossy							
CLUB								
WINDOW								

## W 60

Specify hinge  
R or L

Code		PK32.30S	PK32.31Y	PK32.32E	PK32.33M	PK32.34T	PK32.35Z	PK32.36F
ONE	matte							
	glossy							
CLUB								
WINDOW								

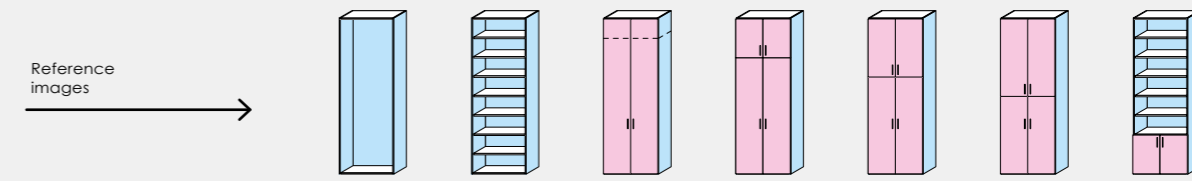

## W 90

Code		PK32.52R	PK32.53X	PK32.54D	PK32.55L	PK32.56S	PK32.57Y	PK32.58E
ONE	matte							
	glossy							
CLUB								
WINDOW								

## W 120

Drawers and big drawers  
CHARM with "Quadro" soft  
rails as standard  
(without surcharges)

Code		PK32.74Q	PK32.75W	PK32.76C	PK32.77K	PK32.78R	PK32.79X	PK32.80U
ONE	matte							
	glossy							
CLUB								
WINDOW								



- OPTIONAL:**  
p. 172
- A · Extra colors for Side panels
  - B · Increased Back panel Th 0.8
  - C · Side panels with led lighting
  - D · Drawers and big drawers with soft-close

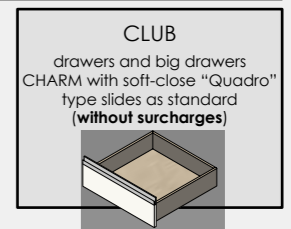

- p. 44 Filler strips
- p. 56 Knob and handle positions
- p. 184 Accessories for Container units Dpt 45



# Container units Ht 257.6 - Dpt 45

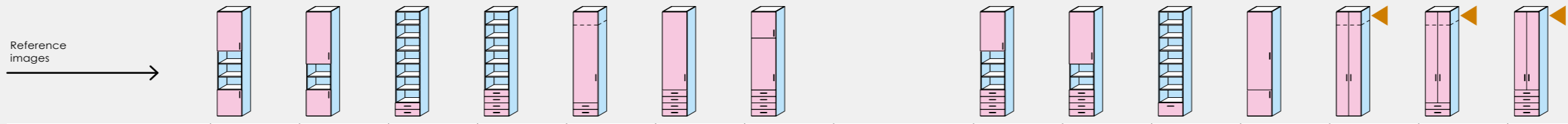

## W 30

Specify hinge  
R or L

Code	PK32.07W	PK32.08C	-	-	-	-	-	-	-	-	-	PK32.09K	-	-	-				
ONE	matte																		
	glossy																		
CLUB																			
WINDOW																			

## W 45

Specify hinge  
R or L

Code	PK32.18H	PK32.19Q	PK32.20M	PK32.21T	PK32.22Z	PK32.23F	PK32.24N		PK32.25U	PK32.26A	PK32.27G	PK32.28P	-	-	-				
ONE	matte																		
	glossy																		
CLUB																			
WINDOW																			

## W 60

Specify hinge  
R or L

Code	PK32.37N	PK32.38U	PK32.39A	PK32.40X	PK32.41D	PK32.42L	PK32.43S		PK32.44Y	PK32.45E	PK32.46M	PK32.47T	PK32.49F	PK32.50C	PK32.51K				
ONE	matte																		
	glossy																		
CLUB																			
WINDOW																			

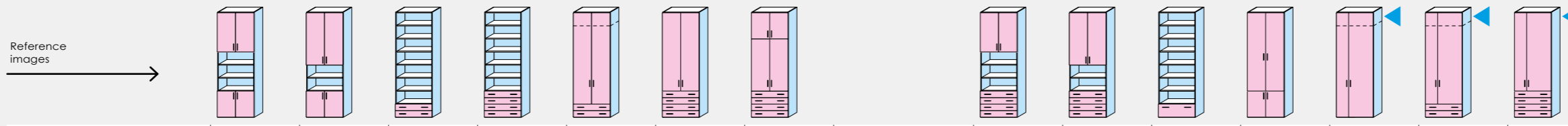

## W 90

Code	PK32.59M	PK32.60H	PK32.61Q	PK32.62W	PK32.63C	PK32.64K	PK32.65R		PK32.66X	PK32.67D	PK32.68L	PK32.69S	PK32.71V	PK32.72B	PK32.73H				
ONE	matte																		
	glossy																		
CLUB																			
WINDOW																			

## W 120

Drawers and big drawers  
CHARM with "Quadro" soft  
rails as standard  
(without surcharges)

Code	PK32.81A	PK32.82G	PK32.83P	PK32.84V	PK32.85B	PK32.86H	PK32.87Q		PK32.88W	PK32.89C	PK32.90Z	PK32.91F	-	-	-				
ONE	matte																		
	glossy																		
CLUB																			
WINDOW																			

- Components in **CARCASE** colors
- Components in **GROUP 2** colors
- Components in **Types and colors FRONT**

- With doors **W 30**
- With doors **W 30 + W 60** - Indicate R or L (drawing - R)



- OPTIONAL:**  
p. 172
- A** · Extra colors for Side panels
  - B** · Increased Back panel Th 0.8
  - C** · Side panels with led lighting
  - D** · Drawers and big drawers with soft-close

**CLUB**  
drawers and big drawers  
CHARM with soft-close "Quadro"  
type slides as standard  
(without surcharges)

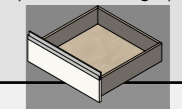

- p. 44** Filler strips
- p. 56** Knob and handle positions
- p. 184** Accessories for Container units Dpt 45

## Filler strip 5.4 - 5.4 (for empty corners)

	Ht 193.6	Ht 225.6	Ht 257.6		
Code	PK11.48P	PK13.48X	PK17.48Q		

## SMART end bookshelf W 43.2 - Dpt 26

For Container units Dpt 45

	Ht 193.6	Ht 225.6	Ht 257.6		
Code	PK20.75K	PK20.76R	PK20.77X		

	<b>HIP</b> Melamine-coated Ht 29,4 W 18 Dpt 25 	<b>HOP</b> Melamine-coated Ht 29,4 W 30 Dpt 25 		
Code	P01.39E	P01.40L		

### Technical information

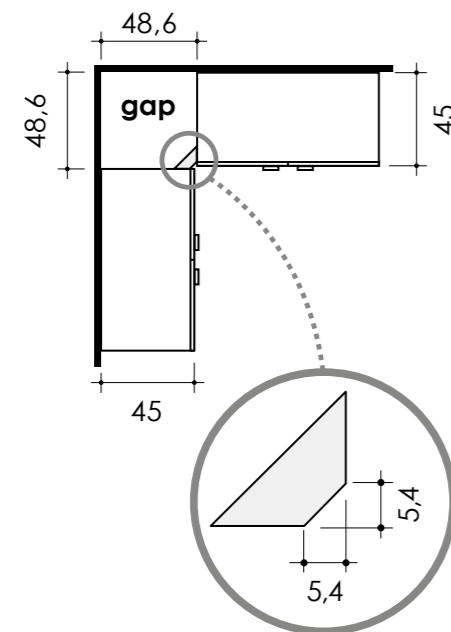

### Technical information

- Fitted with adjustable feet.
- They are not fitted with back panels.
- **The bookshelf must be fixed to container unit side panel using the provided hardware.**
- The shelves are always spaced apart at a distance of 32 cm.
- **For custom cuts consult the relevant chapter.**
- HIP and HOP cannot be inserted in the upper and lower compartment of the element.

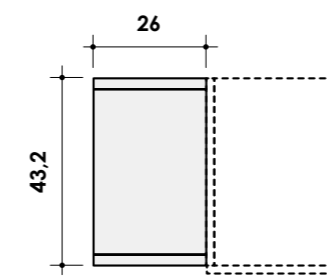

L SMART

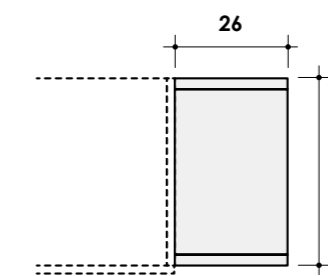

R SMART

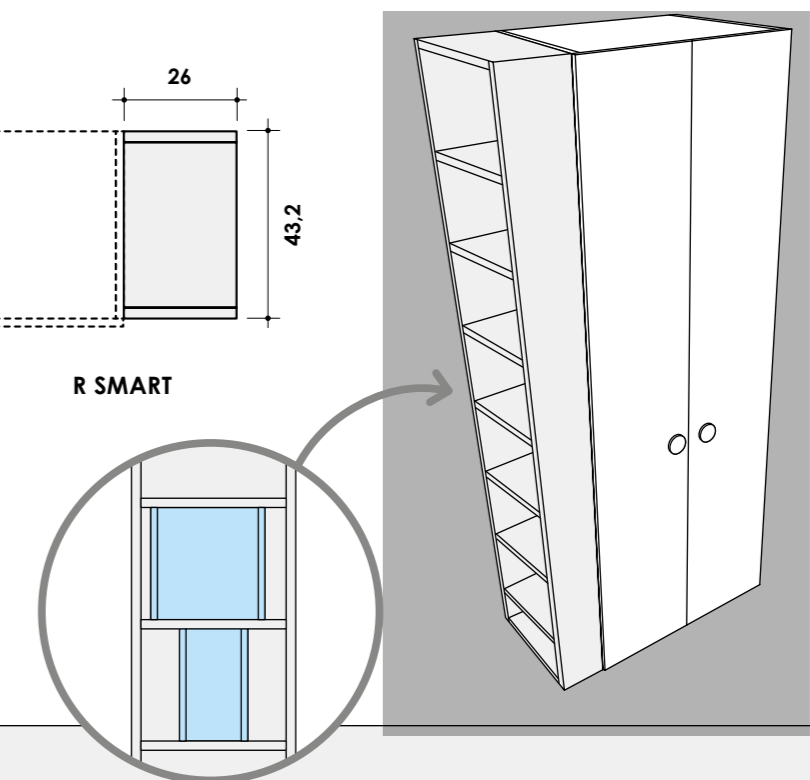

□ Components in **CARCASE** colors  
 ■ Components in **GROUP 2** colors

# Accessories for Container units Dpt 45

**Movable shelf**  
Dpt 41.7 - Th 2.5

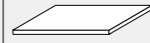

**Transparent tempered glass movable shelf**  
Dpt 41.2 - Th 0.8



W	Code	Code			
30 (26.3)	<b>PK72.92A</b>	<b>PK72.93G</b>			
45 (41.3)	<b>P50.60B</b>	<b>P51.74F</b>			
60 (56.3)	<b>P26.59K</b>	<b>P26.60Q</b>			
90 (86.3)	<b>P50.62N</b>	<b>P51.75M</b>			
120 (116.3)	<b>P02.49N</b>	<b>P02.50T</b>			

**Inner drawer units**  
Cushioned closure devices CANNOT be fitted.  
Dpt 34.3 - W 86.3

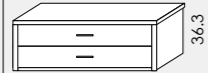

36.3

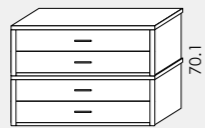

70.1

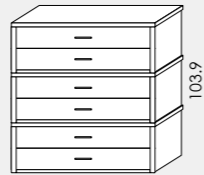

103.9

**Sliding clothes hanging bar**  
Dpt 40



**Dust guard for pair hinged doors**  
Aluminium colour only

256

Code	P52.81X	P52.82C	P52.83H	P50.95S	P01.13P

**BERNARDO**  
Clothes hangers  
Dpt 2  
W 28  
A 1 for elements Ht 193.6;  
1 or 2, at the discretion, for  
elements Ht 225.6 - 257.6.  
B For elements Ht 257.6.  
\* Tray (optional) positions.

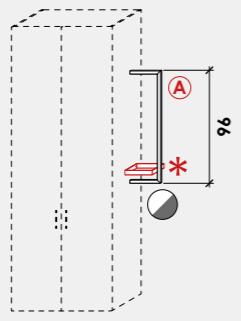

96

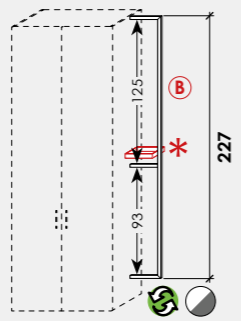

227

**Tray**  
Ht 4  
Dpt 15  
W 25



Code		P07.70T	P08.31K	P08.32Q	

□ Components in **CARCASE** colors  
● B17A GZ8T  
♻️ The element can be turned upside down

# End units Dpt 45 - W 45

## Ht 193.6

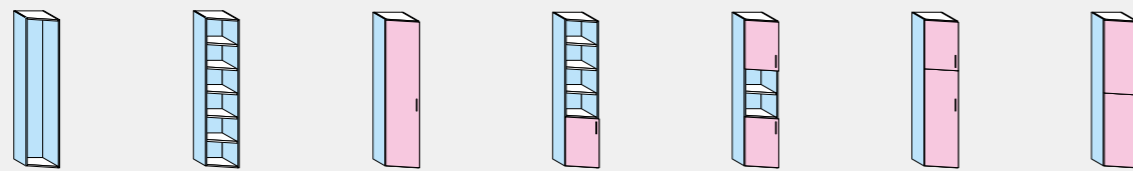

Code	L	PK33.00E	PK33.01M	PK33.02T	PK33.03Z	PK33.04F	PK33.05N	PK33.06U
	R	PK33.07A	PK33.08G	PK33.09P	PK33.10L	PK33.11S	PK33.12Y	PK33.13E
ONE	matte							
	glossy							
CLUB								
WINDOW								

## Ht 225.6

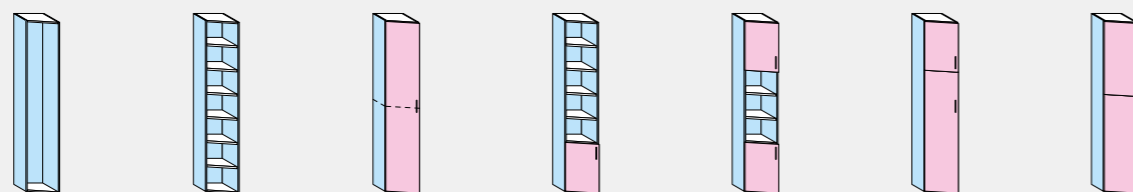

Code	L	PK33.14M	PK33.15T	PK33.16Z	PK33.17F	PK33.18N	PK33.19U	PK33.20R
	R	PK33.21X	PK33.22D	PK33.23L	PK33.24S	PK33.25Y	PK33.26E	PK33.27M
ONE	matte							
	glossy							
CLUB								
WINDOW								

## Ht 257.6

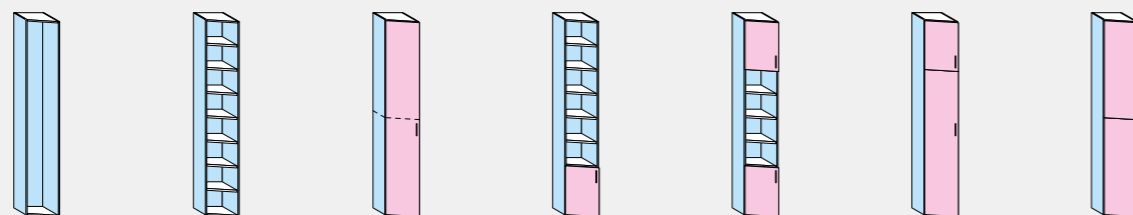

Code	L	PK33.28T	PK33.29Z	PK33.30W	PK33.31C	PK33.32K	PK33.33R	PK33.34X
	R	PK33.35D	PK33.36L	PK33.37S	PK33.38Y	PK33.39E	PK33.40B	PK33.41H
ONE	matte							
	glossy							
CLUB								
WINDOW								

### Technical information

- They are fitted with adjustable feet.
- The doors are with decelerated hinges.
- The clothes hanging bar cannot be fitted.
- The internal equipment supplied consists of melamine-coated movable shelves every 32 cm ONLY in open compartments and 1 melamine-coated movable shelf located in line with doors Ht 224 - 256.
- **For custom cuts consult the relevant chapter.**

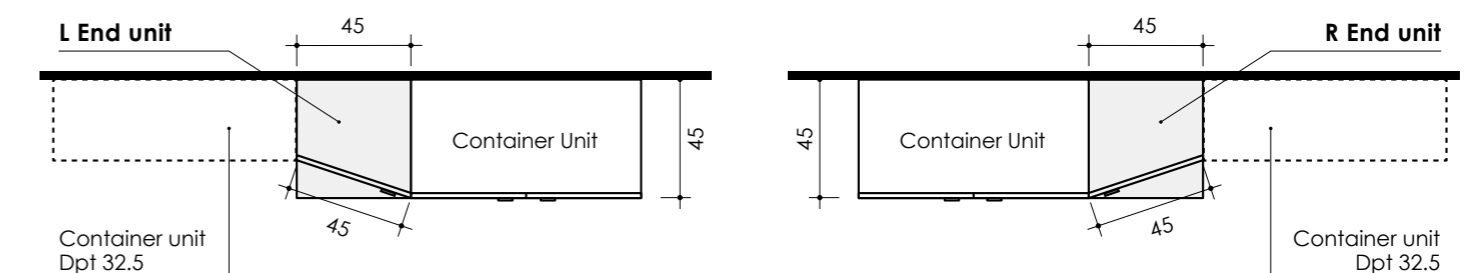

### Movable shelf for end unit

W 41,3  
Dpt 41,7  
Th 2,5



Code	L	P50.66K			
	R	P50.68V			

**OPTIONAL:** p. 172  
**A** · Extra colors for Side panels  
**B** · Increased Back panel Th 0.8  
**C** · Side panels with led lighting

Components in **CARCASE** colors  
 Components in **GROUP 2** colors  
 Components in **Types and colors FRONT**

# Container units Ht 193.6 - Dpt 32.5

Reference images →

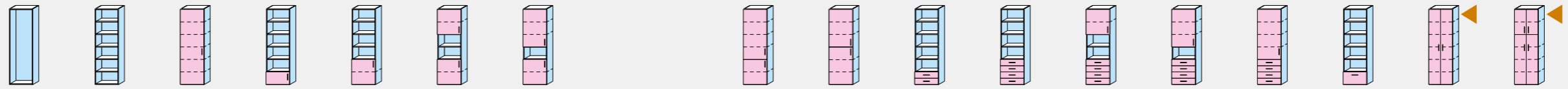

## W 30

Specify hinge R or L

Code	PK34.00K	PK34.01R	PK34.02X	PK34.03D	PK34.04L	PK34.05S	PK34.06Y		PK34.07E	PK34.08M	-	-	-	-	-	-	-	-	-
ONE	matte																		
	glossy																		
CLUB																			
WINDOW																			

## W 45

Specify hinge R or L

Code	PK34.09T	PK34.10Q	PK34.11W	PK34.12C	PK34.13K	PK34.14R	PK34.15X		PK34.16D	PK34.17L	PK34.18S	PK34.19Y	PK34.20V	PK34.21B	PK34.22H	PK34.23Q	-	-	
ONE	matte																		
	glossy																		
CLUB																			
WINDOW																			

## W 60

Specify hinge R or L

Code	PK34.24W	PK34.25C	PK34.26K	PK34.27R	PK34.28X	PK34.29D	PK34.30A		PK34.31G	PK34.32P	PK34.33V	PK34.34B	PK34.35H	PK34.36Q	PK34.37W	PK34.38C	PK34.39K	PK34.40F	
ONE	matte																		
	glossy																		
CLUB																			
WINDOW																			

Reference images →

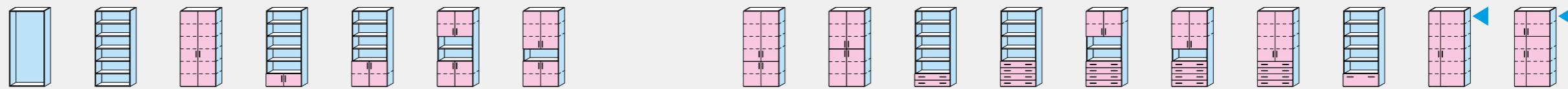

## W 90

Code	PK34.41N	PK34.42U	PK34.43A	PK34.44G	PK34.45P	PK34.46V	PK34.47B		PK34.48H	PK34.49Q	PK34.50M	PK34.51T	PK34.52Z	PK34.53F	PK34.54N	PK34.55U	PK34.56A	PK34.57G
ONE	matte	189,00																
	glossy	-																
CLUB																		
WINDOW																		

## W 120

Code	PK34.58P	PK34.59V	PK34.60S	PK34.61Y	PK34.62E	PK34.63M	PK34.64T		PK34.65Z	PK34.66F	-	-	-	-	-	-	-
ONE	matte																
	glossy																
CLUB																	
WINDOW																	

- Components in **CARCASE** colors
- Components in **GROUP 2** colors
- Components in **Types and colors FRONT**

- ▼ With doors W 30
- ▼ With doors W 30 + W 60 - Indicate R or L (drawing - R)



**OPTIONAL:** p. 172

- A · Extra colors for Side panels
- B · Increased Back panel Th 0.8
- C · Side panels with led lighting
- D · Drawers and big drawers with soft-close

**CLUB**  
drawers and big drawers  
CHARM with soft-close "Quadro"  
type slides as standard  
(without surcharges)

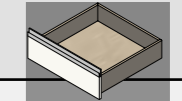

p. 44 Filler strips  
p. 56 Knob and handle positions  
p. 194 Accessories for Container units Dpt 32.5

# Container units Ht 225.6 - Dpt 32.5

Reference images →

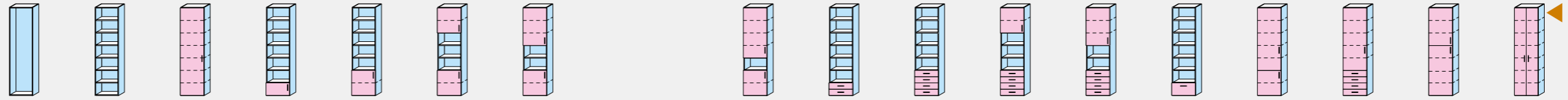

## W 30

Specify hinge R or L

Code	PK35.00P	PK35.01V	PK35.02B	PK35.03H	PK35.04Q	PK35.05W	PK35.06C		PK35.07K	-	-	-	-	-	PK35.08R	-	PK35.09X	-	
ONE	matte																		
	glossy																		
CLUB																			
WINDOW																			

## W 45

Specify hinge R or L

Code	PK35.10U	PK35.11A	PK35.12G	PK35.13P	PK35.14V	PK35.15B	PK35.16H		PK35.17Q	PK35.18W	PK35.19C	PK35.20Z	PK35.21F	PK35.22N	PK35.23U	PK35.24A	PK35.25G	-	
ONE	matte																		
	glossy																		
CLUB																			
WINDOW																			

## W 60

Specify hinge R or L

Code	PK35.26P	PK35.27V	PK35.28B	PK35.29H	PK35.30E	PK35.31M	PK35.32T		PK35.33Z	PK35.34F	PK35.35N	PK35.36U	PK35.37A	PK35.38G	PK35.39P	PK35.40L	PK35.41S	PK35.42Y	
ONE	matte																		
	glossy																		
CLUB																			
WINDOW																			

Reference images →

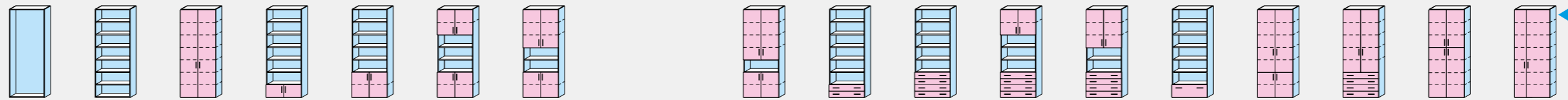

## W 90

Code	PK35.43E	PK35.44M	PK35.45T	PK35.46Z	PK35.47F	PK35.48N	PK35.49U		PK35.50R	PK35.51X	PK35.52D	PK35.53L	PK35.54S	PK35.55Y	PK35.56E	PK35.57M	PK35.58T	PK35.59Z	
ONE	matte																		
	glossy																		
CLUB																			
WINDOW																			

## W 120

Code	PK35.60W	PK35.61C	PK35.62K	PK35.63R	PK35.64X	PK35.65D	PK35.66L		PK35.67S	-	-	-	-	-	PK35.68Y	-	PK35.69E	-	
ONE	matte																		
	glossy																		
CLUB																			
WINDOW																			

- Components in **CARCASE** colors
- Components in **GROUP 2** colors
- Components in **Types and colors FRONT**

- ▼ With doors W 30
- ▼ With doors W 30 + W 60 - Indicate R or L (drawing - R)



**OPTIONAL:**  
p. 172

- A · Extra colors for Side panels
- B · Increased Back panel Th 0.8
- C · Side panels with led lighting
- D · Drawers and big drawers with soft-close

CLUB  
drawers and big drawers  
CHARM with soft-close "Quadro"  
type slides as standard  
(without surcharges)

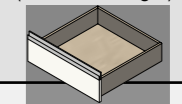

p. 44 Filler strips  
p. 56 Knob and handle positions  
p. 194 Accessories for Container units Dpt 32.5



# Container units Ht 257.6 - Dpt 32.5

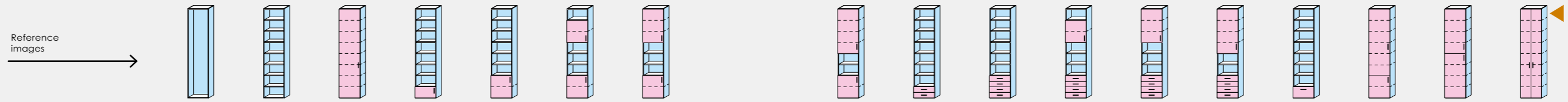

## W 30

Specify hinge  
R or L

Code	PK36.00T	PK36.01Z	PK36.02F	PK36.03N	PK36.04U	PK36.05A	PK36.06G		PK36.07P	-	-	-	-	-	-	PK36.08V	PK36.09B	-	
ONE	matte																		
	glossy																		
CLUB																			
WINDOW																			

## W 45

Specify hinge  
R or L

Code	PK36.10Y	PK36.11E	PK36.12M	PK36.13T	PK36.14Z	PK36.15F	PK36.16N		PK36.17U	PK36.18A	PK36.19G	PK36.20D	PK36.21L	PK36.22S	PK36.23Y	PK36.24E	PK36.25M	-		
ONE	matte																			
	glossy																			
CLUB																				
WINDOW																				

## W 60

Specify hinge  
R or L

Code	PK36.26T	PK36.27Z	PK36.28F	PK36.29N	PK36.30K	PK36.31R	PK36.32X		PK36.33D	PK36.34L	PK36.35S	PK36.36Y	PK36.37E	PK36.38M	PK36.39T	PK36.40Q	PK36.41W	PK36.42C		
ONE	matte																			
	glossy																			
CLUB																				
WINDOW																				

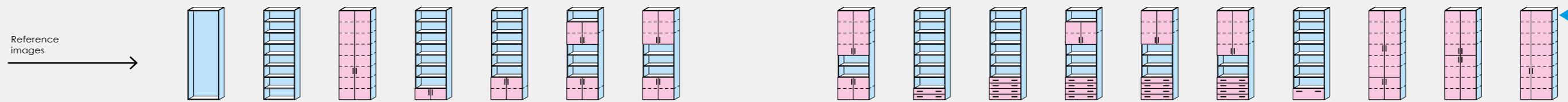

## W 90

Code	PK36.43K	PK36.44R	PK36.45X	PK36.46D	PK36.47L	PK36.48S	PK36.49Y		PK36.50V	PK36.51B	PK36.52H	PK36.53Q	PK36.54W	PK36.55C	PK36.56K	PK36.57R	PK36.58X	PK36.59D		
ONE	matte																			
	glossy																			
CLUB																				
WINDOW																				

## W 120

Code	PK36.60A	PK36.61G	PK36.62P	PK36.63V	PK36.64B	PK36.65H	PK36.66Q		PK36.67W	-	-	-	-	-	-	PK36.68C	PK36.69K	-		
ONE	matte																			
	glossy																			
CLUB																				
WINDOW																				

- Components in **CARCASE** colors
- Components in **GROUP 2** colors
- Components in **Types and colors FRONT**

- ▼ With doors W 30
- ▼ With doors W 30 + W 60 - Indicate R or L (drawing - R)



- OPTIONAL:** p. 172
- A · Extra colors for Side panels
  - B · Increased Back panel Th 0.8
  - C · Side panels with led lighting
  - D · Drawers and big drawers with soft-close

CLUB  
drawers and big drawers  
CHARM with soft-close "Quadro"  
type slides as standard  
(without surcharges)

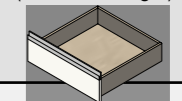

- p. 44 Filler strips
- p. 56 Knob and handle positions
- p. 194 Accessories for Container units Dpt 32.5

# Accessories for Container units Dpt 32.5

**Movable shelf**  
Dpt 28.6 - Th 2.5



**Transparent tempered glass movable shelf**  
Dpt 28 - Th 0.8



W	Code	Code			
30 (26.3)	<b>P07.76A</b>	<b>P07.24T</b>			
45 (41.3)	<b>P36.72G</b>	<b>P07.25Y</b>			
60 (56.3)	<b>P37.80D</b>	<b>P07.26D</b>			
90 (86.3)	<b>P36.71B</b>	<b>P07.27K</b>			
120 (116.3)	<b>PK01.85N</b>	<b>PK01.86U</b>			

**Sliding clothes hanging bar**  
Dpt 24.5



**Dust guard for pair hinged doors**  
Aluminium colour only



**HIP**  
Melamine-coated  
Ht 29.4 - W 18 - Dpt 25

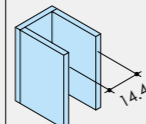

**HOP**  
Melamine-coated  
Ht 29.4 - W 30 - Dpt 25

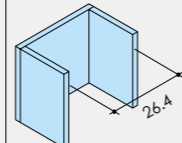

HIP and HOP cannot be inserted in the upper compartment of the Container units.

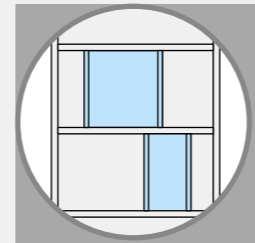

Code	P48.50W	P01.13P	P01.39E	P01.40L	
------	---------	---------	---------	---------	--

**BERNARDO**  
Clothes hangers  
Dpt 2  
W 28

- A** 1 for elements Ht 193.6; 1 or 2, at the discretion, for elements Ht 225.6 - 257.6.
- B** For elements Ht 257.6.
- \* Tray (optional) positions.

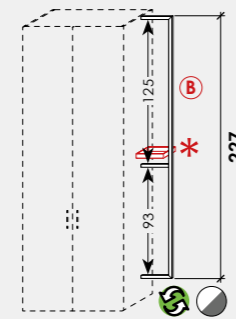
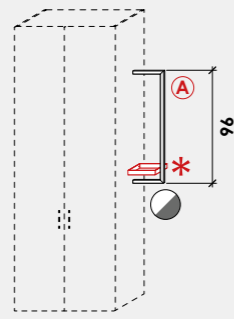

**Tray**

Ht 4  
Dpt 15  
W 25

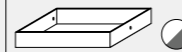

Code		P07.70T	P08.31K	P08.32Q	
------	--	---------	---------	---------	--

□ Components in **CARCASE** colors

■ Components in **GROUP 2** colors

♻ The element can be turned upside down

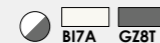

GROUP 1 colors	Rovere Dorian <b>RD5T</b>	Rovere white <b>RW3Q</b>	Noce naturale <b>NN7H</b>	Eucalipto <b>CL1X</b>	Domy <b>DM7P</b>	Bianco UV <b>BU3Q</b>
	Ciliegio bianco <b>CB6K</b>	Malta <b>ML7H</b>	Feltro <b>FL8X</b>	Cemento Masdar <b>CM3Q</b>	Blu indaco <b>BI4B</b>	
	Noce <b>NC4B</b>	Desert <b>DS9L</b>	Canapa <b>CN1X</b>	Moka <b>MK6B</b>	Cipria <b>CP4J</b>	
	Bianco opaco <b>BI7A</b>	Grigio Dorian <b>GL4R</b>	Basalto <b>BS5T</b>	Grigio titanio <b>GZ8T</b>	Rosa bubble <b>RB7Y</b>	
	Agave <b>GV7A</b>	Verde Alpi <b>VA5T</b>	Cadaques <b>CQ3Q</b>	Giallo zafferano <b>GZ8A</b>		
	Blu opale <b>BO7H</b>			Corallo <b>CR5T</b>		

Wardrobes sliding doors

Wardrobes with sliding doors - technical information	198
OPTIONAL for wardrobes with sliding doors	200
Wardrobes Dpt 61.5 with LINEAR sliding doors W 90	202
Wardrobes Dpt 61.5 with SECTOR sliding doors W 90 and 135	204
Wardrobes Dpt 61.5 with DIAGONAL and SECTOR sliding doors W 135	206
Wardrobes Dpt 61.5 with RIVIERA sliding doors W 90 and 135	208
Wardrobes Dpt 61.5 with INSERTO sliding doors W 90 and 135	209
Accessories for wardrobes with sliding doors	210

**Types and colors FRONT**

**ONE**  
matte  
glossy

**CLUB**

**WINDOW**

Rovere white <b>RW3Q</b>	Rovere Dorian <b>RD5T</b>	Ciliegio bianco <b>CB6K</b>	Noce naturale <b>NN7H</b>	Noce <b>NC4B</b>	Eucalipto <b>CL1X</b>	Malta <b>ML7H</b>
Feltro <b>FL8X</b>	Cemento Masdar <b>CM3Q</b>	Bianco opaco <b>BI7A</b>	Desert <b>DS9L</b>	Canapa <b>CN1X</b>	Moka <b>MK6B</b>	Grigio Dorian <b>GL4R</b>
Basalto <b>BS5T</b>	Grigio titanio <b>GZ8T</b>	Domy <b>DM7P</b>	Agave <b>GV7A</b>	Verde Alpi <b>VA5T</b>	Cadaques <b>CQ3Q</b>	Blu indaco <b>BI4B</b>
Blu opale <b>BO7H</b>	Cipria <b>CP4J</b>	Rosa bubble <b>RB7Y</b>	Giallo zafferano <b>GZ8A</b>	Corallo <b>CR5T</b>		

**Specify the color of the CLUB handle**

Bianco opaco <b>BI7A</b>	Desert <b>DS9L</b>	Canapa <b>CN1X</b>	Moka <b>MK6B</b>	Grigio Dorian <b>GL4R</b>	Basalto <b>BS5T</b>	Grigio titanio <b>GZ8T</b>
Domy <b>DM7P</b>	Agave <b>GV7A</b>	Verde Alpi <b>VA5T</b>	Cadaques <b>CQ3Q</b>	Blu indaco <b>BI4B</b>	Blu opale <b>BO7H</b>	Cipria <b>CP4J</b>
Rosa bubble <b>RB7Y</b>	Giallo zafferano <b>GZ8A</b>	Corallo <b>CR5T</b>				

**Specify the color of the aluminum frame**

Trasparente <b>TR9M</b>	Trasparente fumé <b>FT8P</b>	Stop-sol <b>ST6P</b>	Specchio <b>SP7L</b>
Alluminio <b>AL1A</b>	Titan grey <b>TG7H</b>		

Wardrobes sliding doors

# Wardrobes with sliding doors - technical information

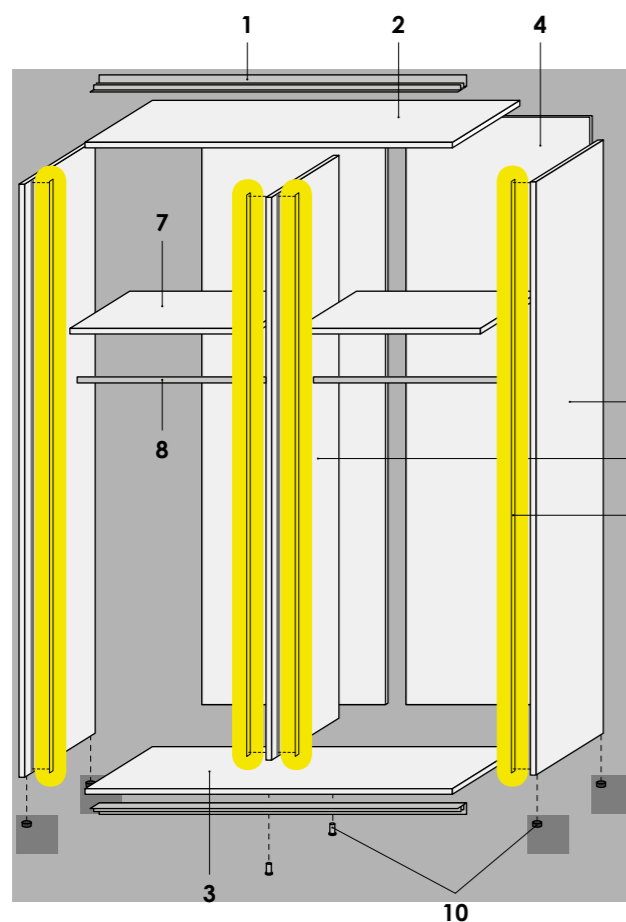

## Components:

- 1 Sliding system rails
- 2 Top panel Th 2.5 - With eccentric pin system
- 3 Bottom panel Th 2.5 - With eccentric pin system
- 4 Back panels Th 0.3 or 0.8 (optional) - Fitting into shaped connection.
- 5 External side panels Th 2.5 - With prefitted hardware.
- 6 Central panel (partition) Th 2.5
- 7 Movable shelves Th 2.5 Dpt 51.5 - On runner.
- 8 BASIC clothes hanging bar in chromed metal or PLUS clothes hanging bar (optional) in aluminum.
- 9 Strip led (optional) - In full height milled groove.
- 10 Adjustable feet - Adjustable from inside the wardrobe. Max. adjustment 1 cm.

## Dimensions:

- W** 180,1 (2 doors/sections)  
 268,9 (3 doors/sections)  
 268,9 (2 doors/sections)  
**Dpt** 61,5 (with sliding doors)  
**Ht** 225,6 - 241,6 - 257,6

- These structures can only be placed on the ground.
- Tops are not finished.
- They are equipped with adjustable feet.
- The wardrobes can be placed side by side.

## IMPORTANT!

- The mirror Th 0.4 is applied on a white melamine-coated panel Th 1.4.
- **Internal fittings supplied for every niche:** 2 clothes hanging bars and 1 melamine-coated movable shelf.
- **For custom cuts consult the relevant chapter.**
- We recommend fixing them to the wall with the provided hardware; if the depth has been reduced, they must be anchored to the wall.
- With small depth wardrobes we recommend using sliding clothes rails.
- For assembly, at least an extra 4 cm in width and at least an extra 8 cm in height is required (for the correct sliding of the doors in the niche you need at least 4 cm in height).

When ordering wardrobes with 2 doors, it is essential to specify whether the projecting door is R or L. The side panel next to the projecting door has depth 58 cm, while the side panel next to the non-projecting door is 54.5 cm deep.

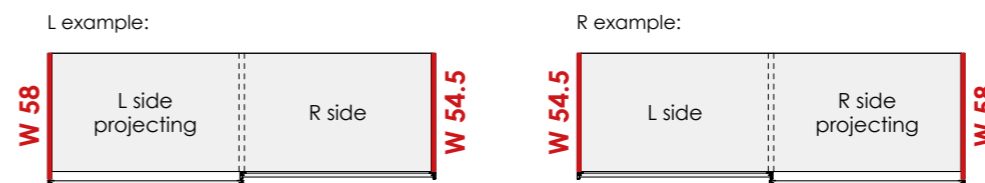

The door opening diagram applies for all wardrobes with sliding doors. **Door opening directions cannot be reversed.**

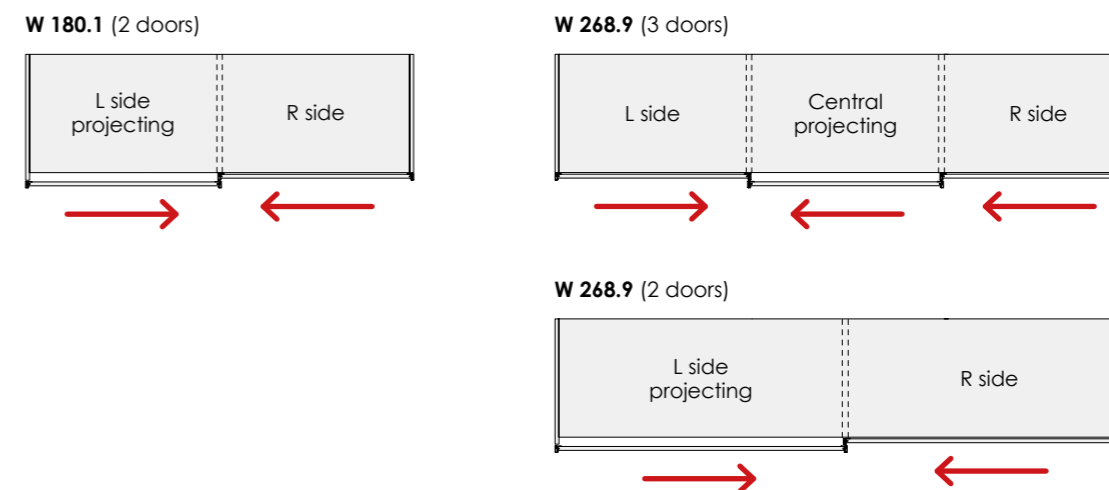

# OPTIONAL for wardrobes with sliding doors

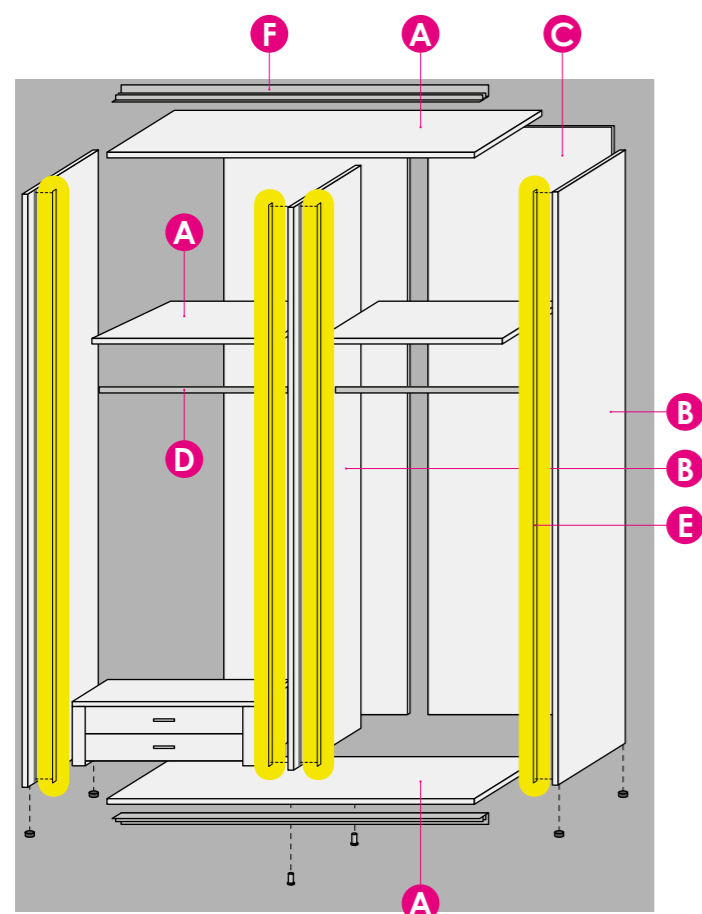

## A Extra colors for Top panel, Bottom panel and Shelves

In addition to the standard CARCASE colors, these components are all available in the GROUP 2 colors with surcharge (see table).

- **When placing the order:** indicate the colour in the HORIZONTAL FINISHES variant in Metron 4: the top panel, bottom panel and shelves will automatically be delivered in that colour (if specified, the various elements can be coloured as preferred).
- **N.B.** The surcharge is applied to each single component.

Top panel Bottom panel	Surcharge for single element (CARCASE colors excluded)
W 180,1	
W 268,9	
Shelves	Surcharge for single element (CARCASE colors excluded)
W 90	
W 135	

## D PLUS clothes-hanging bar

On request the wardrobe can be equipped with PLUS clothes-hanging bars with surcharge (see table). The PLUS clothes-hanging bar is in aluminium Ø 2,8, available in the Alluminio (AL1A) and Grigio titanio (GZ8T) colors.

- **When placing the order:** indicate PLUS clothes-hanging bar in the BAR TYPE variant and the colour in the BAR COLOUR variant in Metron 4.



Clothes-hanging bar	Surcharge for single element
W 90	
W 135	

## B Extra colors for Side panels

In addition to the standard CARCASE colors, the side panels are available in all the GROUP 2 colors with surcharge (see table).

- **When placing the order:** indicate the colour in the COLOURED FINISHES variant in Metron 4: all side panels will automatically be delivered in that colour (if specified, 1, 2 or more Side panels can be coloured as preferred).
- **N.B.** The surcharge is applied to each single side panel.

Side panels	Surcharge for single element (CARCASE colors excluded)
Ht 225,6	
Ht 241,6	
Ht 257,6	

## E Side panels with led lighting

On request the side panels can be equipped with led lighting, with surcharge (see table). Lighting consists in a full-height led strip inset into the side panel.

- **When placing the order:** indicate LIGHT RH SIDE, LIGHT LH SIDE or LIGHT ON BOTH SIDES in the SIDE PANEL LIGHTING variant in Metron 4. The choice applies to all Wardrobe compartments.



for Wardrobe 2 compartments	Surcharge	
	L or R side panels 2 led strips + 2 sensors + 2 power packs	All side panels 4 led strips + 2 sensors + 2 power packs
Ht 225,6		
Ht 241,6		
Ht 257,6		
for Wardrobe 3 compartments	Surcharge	
	L or R side panels 3 led strips + 3 sensors + 3 power packs	All side panels 6 led strips + 3 sensors + 3 power packs
Ht 225,6		
Ht 241,6		
Ht 257,6		

## C Increased Back panel Th 0.8

On request the Wardrobe can be equipped with back panels Th 0.8 with surcharge (see table), in replacement of the standard back panel Th 0.3; unlike the standard one (in the CARCASE colors), the increased back panel are available in all GROUP 2 colors.

- **When placing the order:** indicate YES for increased back panel in the BACK PANEL TYPE variant and the colour in the BACK PANEL COLOUR variant in Metron 4.

Back panel Th 0.8 for wardrobe	Surcharge for single element
	Ht 225,6 - 241,6 - 257,6
W 180,1 (2 sections)	
W 268,9 (3 sections)	
W 268,9 (2 sections)	

## F Soft-close sliding doors

On request the doors can be equipped with soft-close opening/closure, with surcharge (see table).

- **When placing the order:** indicate soft-close doors in the DOOR SOFT-CLOSE variant in Metron 4.

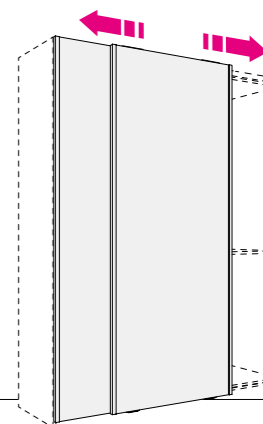

Slow opening/closing	Surcharge
2 sliding doors	
3 sliding doors	

# Wardrobes Dpt 61.5 with LINEAR sliding doors W 90

	W 180.1				W 268.9			
<b>Ht 225.6</b>								
Indicate whether projecting door is R or L								
<b>Code</b>	<b>PK23.44Z</b>	<b>PK23.45F</b>	<b>PK23.46N</b>	<b>PK23.47U</b>	<b>PK23.48A</b>	<b>PK23.49G</b>	<b>PK23.50D</b>	<b>PK23.51L</b>
ONE	matte							
	glossy							
<b>Ht 241.6</b>								
Indicate whether projecting door is R or L								
<b>Code</b>	<b>PK24.10M</b>	<b>PK24.11T</b>	<b>PK24.12Z</b>	<b>PK24.13F</b>	<b>PK24.19V</b>	<b>PK24.20S</b>	<b>PK24.21Y</b>	<b>PK24.22E</b>
ONE	matte							
	glossy							
<b>Ht 257.6</b>								
Indicate whether projecting door is R or L								
<b>Code</b>	<b>PK23.52S</b>	<b>PK23.53Y</b>	<b>PK23.54E</b>	<b>PK23.55M</b>	<b>PK23.56T</b>	<b>PK23.57Z</b>	<b>PK23.58F</b>	<b>PK23.59N</b>
ONE	matte							
	glossy							

Wardrobes sliding doors

- Components in **GROUP 2 colors**
- Components in **Types and colors FRONT**
- Mirror

- OPTIONAL:** **p. 200**
- A** · Extra colors for Top panel, Bottom panel and Shelves
  - B** · Extra colors for Side panels
  - C** · Increased back panel Th 0.8
  - D** · PLUS clothes rail
  - E** · Side panels with led lighting
  - F** · Soft-close sliding doors

- p. 44** Filler strips  
**p. 210** Accessories for Wardrobe Dpt 56.3



# Wardrobes Dpt 61.5 with SECTOR sliding doors W 90 and 135

## Ht 225.6

Indicate whether projecting door is R or L

	W 180.1			W 268.9						
<b>Code</b>	<b>PK23.60K</b>	<b>PK23.61R</b>	<b>PK23.62X</b>	<b>PK23.63D</b>	<b>PK23.64L</b>	<b>PK23.65S</b>	<b>PK23.67E</b>	<b>PK23.68M</b>	<b>PK23.69T</b>	<b>PK23.96Q</b>
ONE	matte									
	glossy									

## Ht 241.6

Indicate whether projecting door is R or L

<b>Code</b>	<b>PK24.14N</b>	<b>PK24.15U</b>	<b>PK24.16A</b>	<b>PK24.17G</b>	<b>PK24.18P</b>	<b>PK24.23M</b>	<b>PK24.25Z</b>	<b>PK24.26F</b>	<b>PK24.27N</b>	<b>PK24.28U</b>
ONE	matte									
	glossy									

## Ht 257.6

Indicate whether projecting door is R or L

<b>Code</b>	<b>PK23.70Q</b>	<b>PK23.71W</b>	<b>PK23.72C</b>	<b>PK23.73K</b>	<b>PK23.74R</b>	<b>PK23.75X</b>	<b>PK23.77L</b>	<b>PK23.78S</b>	<b>PK23.79Y</b>	<b>PK24.05P</b>
ONE	matte									
	glossy									

### CUSTOMISATION OF FRONTS

The SECTOR doors consist of 2 vertically joined panels. The panel with the narrower section is always placed on the left. You can customise the wardrobe fronts by specifying the desired colour for each panel. To position the colors correctly, you must send a drawing of the wardrobe.

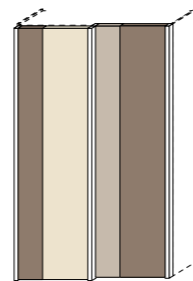

- Components in **GROUP 2 colors**
- Components in **Types and colors FRONT**
- Mirror



**OPTIONAL:**  
p. 200

- A · Extra colors for Top panel, Bottom panel and Shelves
- B · Extra colors for Side panels
- C · Increased back panel Th 0.8
- D · PLUS clothes rail
- E · Side panels with led lighting
- F · Soft-close sliding doors



p. 44 Filler strips  
p. 210 Accessories for Wardrobe Dpt 56.3

# Wardrobes Dpt 61.5 with DIAGONAL and SECTOR sliding doors W 135

W 268.9

## Ht 225.6

Indicate whether projecting door is R or L

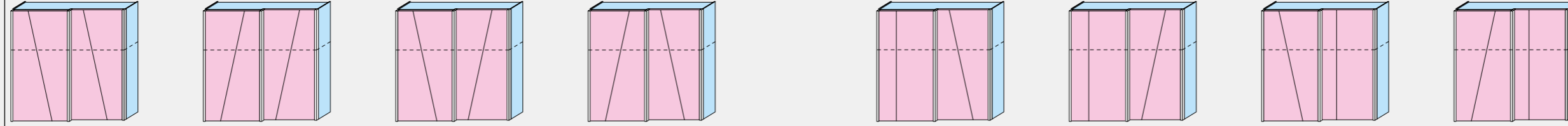

Code	PK23.92P	PK23.93V	PK23.94B	PK23.95H	PK23.97W	PK23.98C	PK23.99K	PK24.00F	
ONE	matte								
	glossy								

## Ht 257.6

Indicate whether projecting door is R or L



Code	PK24.01N	PK24.02U	PK24.03A	PK24.04G	PK24.06V	PK24.07B	PK24.08H	PK24.09Q	
ONE	matte								
	glossy								

Wardrobes sliding doors

### CUSTOMISATION OF FRONTS

The DIAGONAL doors consist of 2 diagonally joined panels. The SECTOR doors consist of 2 vertically joined panels; the panel with the narrower section is always placed on the left. You can customise the wardrobe fronts by specifying the desired colour for each panel. To position the colors correctly, you must send a drawing of the wardrobe.

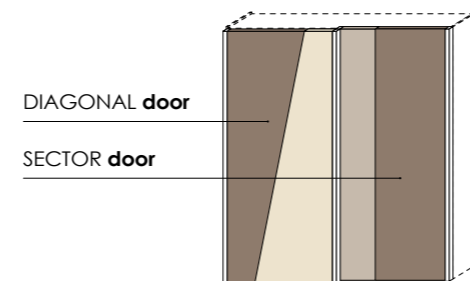

- Components in **GROUP 2 colors**
- Components in **Types and colors FRONT**



- OPTIONAL:** p. 200
- A · Extra colors for Top panel, Bottom panel and Shelves
  - B · Extra colors for Side panels
  - C · Increased back panel Th 0.8
  - D · PLUS clothes rail
  - E · Side panels with led lighting
  - F · Soft-close sliding doors



- p. 44 Filler strips
- p. 210 Accessories for Wardrobe Dpt 56.3

# Wardrobes Dpt 61.5 with RIVIERA sliding doors W 90 and 135

# Wardrobes Dpt 61.5 with INSERTO sliding doors W 90 and 135

## Ht 225.6

Indicate whether projecting door is R or L

	W 180.1	W 268.9		
<b>Code</b>	<b>PK24.50H</b>	<b>PK24.51Q</b>	<b>PK24.52W</b>	
ONE	matte			
	glossy			

## Ht 241.6

Indicate whether projecting door is R or L

	W 180.1	W 268.9		
<b>Code</b>	<b>PK24.53C</b>	<b>PK24.54K</b>	<b>PK24.55R</b>	
ONE	matte			
	glossy			

## Ht 257.6

Indicate whether projecting door is R or L

	W 180.1	W 268.9		
<b>Code</b>	<b>PK24.56X</b>	<b>PK24.57D</b>	<b>PK24.58L</b>	
ONE	matte			
	glossy			

### CUSTOMISATION OF FRONTS

The RIVIERA doors consist of 3 vertically joined panels. You can customise the wardrobe fronts by specifying the desired colour for each panel. To position the colors correctly, you must send a drawing of the wardrobe.

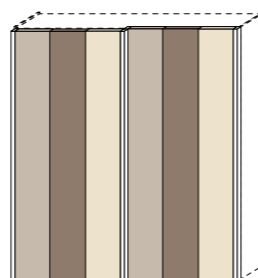

## Ht 225.6

Indicate whether projecting door is R or L

	W 180.1	W 268.9		
<b>Code</b>	<b>PK23.80V</b>	<b>PK23.81B</b>	<b>PK23.84W</b>	
ONE	matte			
	glossy			

## Ht 241.6

Indicate whether projecting door is R or L

	W 180.1	W 268.9		
<b>Code</b>	<b>PK24.29A</b>	<b>PK24.30X</b>	<b>PK24.31D</b>	
ONE	matte			
	glossy			

## Ht 257.6

Indicate whether projecting door is R or L

	W 180.1	W 268.9		
<b>Code</b>	<b>PK23.82H</b>	<b>PK23.83Q</b>	<b>PK23.85C</b>	
ONE	matte			
	glossy			

### CUSTOMISATION OF FRONTS

The INSERTO doors consist of 3 horizontally joined panels. You can customise the wardrobe fronts by specifying the desired colour for each panel. To position the colors correctly, you must send a drawing of the wardrobe.

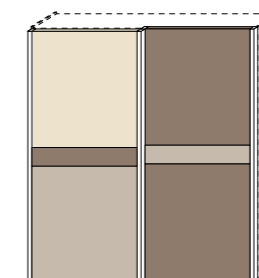

- Components in **GROUP 2 colors**
- Components in **Types and colors FRONT**

- OPTIONAL:** p. 200
- A** · Extra colors for Top panel, Bottom panel and Shelves
  - B** · Extra colors for Side panels
  - C** · Increased back panel Th 0.8
  - D** · PLUS clothes rail
  - E** · Side panels with led lighting
  - F** · Soft-close sliding doors

- p. 44 Filler strips
- p. 210 Accessories for Wardrobe Dpt 56.3



# Accessories for wardrobes with sliding doors

	Movable shelf Dpt 51.5 Th 2.5	Movable transparent glass shelf Dpt 51 Th 0.8	BASIC clothes hanging bar	PLUS clothes hanging bar	Cantilever clothes rail with spacers Ht 84
	<b>Code</b>	<b>Code</b>	<b>Code</b>	<b>Code</b>	<b>Code</b>
90 (86.3) *	PK01.03F	PL04.13B	P50.81R	PK01.45R	P02.59S
135 (130.7) *	PK01.67Q	-	PL19.68M	PK01.66H	-

	Sliding clothes rail Recommended for wardrobes with small depth: Dpt 40 = for depth greater than 40 cm. Dpt 24.5 = for depth less than 40 cm.	Metal clothes reacher pole Ht 115	Hanging shoe rack W 45 - 70 For mounting on inner side
<b>Code</b>	P50.95S	P48.50W	PL04.17C

	Tie rack hooks Can be inserted where the icon is shown W 42	Coin tray Can be inserted where the icon is shown W 42	Example of pant rack with tie rack hooks and coin tray.
<b>Code</b>	P07.12C	P07.13H	

## W 90

	Inner drawer unit Drawers Ht 21.3 Dpt 45.8	Inner drawer units Drawers Ht 16 Dpt 45.8	Inner drawer unit Drawers Ht 18.5 with frame and glass Dpt 45.8
<b>Code</b>	PK01.68W	PK01.69C	PK01.72N

	Pull-out shoe rack Dpt 46.5 Ht 17.2	Metal pull-out basket Dpt 46.5 Ht 12.4	Pull-out pant rack Dpt 46.5 Ht 8	Pull-out tie and belt rack + pant rack Dpt 46.5 Ht 8	2 pull-out fabric laundry baskets Dpt 46.5 Ht 41.5	Pull-out basket Dpt 50 Ht 12
<b>Code</b>	P07.04K	P07.05Q	P07.07A	P07.08F	P07.10S	P50.45V

## W 135

Accessories can only be applied to the bottom of the wardrobe.

	Inner drawer unit Drawers Ht 21.3 Dpt 45.8	Inner drawer unit Drawers Ht 16 Dpt 45.8	Inner drawer unit Drawers Ht 18.5 with frame and glass Dpt 45.8	Equipped honeycomb structures W 130.7 - Dpt 45.8 - Ht 68.3 With shelf	With transparent glass shelf
<b>Code</b>	PK01.73U	PK01.74A	PK01.75G	PK01.76P	PK01.77V

	With pull-out shoe rack	With metal pull-out basket	With pull-out pant rack	With pull-out tie and belt rack + pant rack	With 2 pull-out fabric laundry baskets
<b>Code</b>	PK01.78B	PK01.79H	PK01.80E	PK01.81M	PK01.82T

## W 135

Accessories can only be applied to the bottom of the wardrobe.

	Wardrobe separator with clothes hanging bar BASIC* * It can be replaced with the PLUS W 90 (with surcharge).	Shelf for Wardrobe separator W 86.3 - Dpt 45.8 - Th 2.5	Movable transparent glass shelf for Wardrobe separator W 86.3 - Dpt 41.2 - Th 0.8
<b>Code</b>	PK01.83Z	PK01.37Y	P51.75M

**WARDROBE SEPARATOR**

Including clothes rail W 86.3 and shelves W 41.9. **Internal compartment W 86.3.** Can be fitted with accessories for 90-cm wide wardrobes and with a shelves for Wardrobe separator. Storage compartments and Wardrobe separator can only be added to the bottom of the wardrobe.

**Example:**

- Shelf for Wardrobe separator PK01.37Y
- Metal pull-out basket P07.05Q
- Inner drawer unit PK01.69C

Components in **GROUP 2 colors**

- RW3Q RD5T CB6K GZ8T
- AL1A GZ8T

\* Price of the element in the GROUP 2 colors (CARCASE colors excluded)

**OPTIONAL:** p. 200 **D** - PLUS clothes rail (for Wardrobe separator)

**p. 56** Knob and handle positions

With soft-close adjustable height "Quadro" type metal slides. Drawers internal color CHARM (without surcharges)

Wardrobes sliding doors

# Accessories for wardrobes with sliding doors

## Lighting with sensor

Complete kits with 1 Power pack.  
Cover color Aluminum and Titanium.

W 19,2

Dpt 11,2

Th 0,6

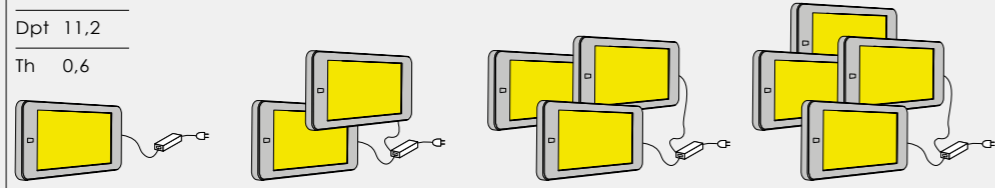

<b>Code</b>	<b>P08.71B</b>	<b>P08.72G</b>	<b>P08.73N</b>	<b>P08.74T</b>	
-------------	----------------	----------------	----------------	----------------	--

## BERNARDO Clothes hangers

Dpt 2

W 28

**A** 1 or 2, at the discretion, for elements Ht 225.6 - 241.6 - 257.6.

**B** For elements Ht 241.6 - 257.6.

\* Tray (optional) positions

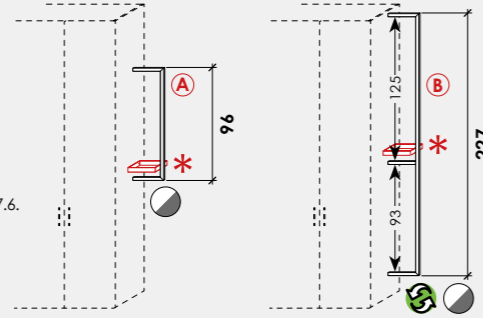

## Tray

Ht 4

Dpt 15

W 25

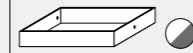

<b>Code</b>		<b>P07.70T</b>	<b>P08.31K</b>	<b>P08.32Q</b>	
-------------	--	----------------	----------------	----------------	--

The element can be turned upside down

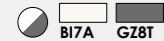

GROUP 1 colors	Rovere Dorian <b>RD5T</b>	Rovere white <b>RW3Q</b>	Noce naturale <b>NN7H</b>	Eucalipto <b>CL1X</b>	Domy <b>DM7P</b>	Bianco UV <b>BU3Q</b>
	Ciliegio bianco <b>CB6K</b>	Malta <b>ML7H</b>	Feltro <b>FL8X</b>	Cemento Masdar <b>CM3Q</b>	Blu indaco <b>BI4B</b>	
	Noce <b>NC4B</b>	Desert <b>DS9L</b>	Canapa <b>CN1X</b>	Moka <b>MK6B</b>	Cipria <b>CP4J</b>	
	Bianco opaco <b>BI7A</b>	Grigio Dorian <b>GL4R</b>	Basalto <b>BS5T</b>	Grigio titanio <b>GZ8T</b>	Rosa bubble <b>RB7Y</b>	
	Agave <b>GV7A</b>	Verde Alpi <b>VA5T</b>	Cadaques <b>CQ3Q</b>	Giallo zafferano <b>GZ8A</b>		
	Blu opale <b>BO7H</b>			Corallo <b>CR5T</b>		

Types and colors FRONT	ONE	Rovere white <b>RW3Q</b>	Rovere Dorian <b>RD5T</b>	Ciliegio bianco <b>CB6K</b>	Noce naturale <b>NN7H</b>	Noce <b>NC4B</b>	Eucalipto <b>CL1X</b>	Malta <b>ML7H</b>	
		Feltro <b>FL8X</b>	Cemento Masdar <b>CM3Q</b>	Bianco opaco <b>BI7A</b>	Desert <b>DS9L</b>	Canapa <b>CN1X</b>	Moka <b>MK6B</b>	Grigio Dorian <b>GL4R</b>	
		Basalto <b>BS5T</b>	Grigio titanio <b>GZ8T</b>	Domy <b>DM7P</b>	Agave <b>GV7A</b>	Verde Alpi <b>VA5T</b>	Cadaques <b>CQ3Q</b>	Blu indaco <b>BI4B</b>	
		Blu opale <b>BO7H</b>	Cipria <b>CP4J</b>	Rosa bubble <b>RB7Y</b>	Giallo zafferano <b>GZ8A</b>	Corallo <b>CR5T</b>			
		Bianco UV <b>BU3Q</b>							
	CLUB	Rovere white <b>RW3Q</b>	Rovere Dorian <b>RD5T</b>	Ciliegio bianco <b>CB6K</b>	Noce naturale <b>NN7H</b>	Noce <b>NC4B</b>	Eucalipto <b>CL1X</b>	Malta <b>ML7H</b>	
Feltro <b>FL8X</b>		Cemento Masdar <b>CM3Q</b>	Bianco opaco <b>BI7A</b>	Desert <b>DS9L</b>	Canapa <b>CN1X</b>	Moka <b>MK6B</b>	Grigio Dorian <b>GL4R</b>		
Basalto <b>BS5T</b>		Grigio titanio <b>GZ8T</b>	Domy <b>DM7P</b>	Agave <b>GV7A</b>	Verde Alpi <b>VA5T</b>	Cadaques <b>CQ3Q</b>	Blu indaco <b>BI4B</b>		
Blu opale <b>BO7H</b>		Cipria <b>CP4J</b>	Rosa bubble <b>RB7Y</b>	Giallo zafferano <b>GZ8A</b>	Corallo <b>CR5T</b>				
		Specify the color of the CLUB handle							
		Bianco opaco <b>BI7A</b>	Desert <b>DS9L</b>	Canapa <b>CN1X</b>	Moka <b>MK6B</b>	Grigio Dorian <b>GL4R</b>	Basalto <b>BS5T</b>	Grigio titanio <b>GZ8T</b>	
		Domy <b>DM7P</b>	Agave <b>GV7A</b>	Verde Alpi <b>VA5T</b>	Cadaques <b>CQ3Q</b>	Blu indaco <b>BI4B</b>	Blu opale <b>BO7H</b>	Cipria <b>CP4J</b>	
		Rosa bubble <b>RB7Y</b>	Giallo zafferano <b>GZ8A</b>	Corallo <b>CR5T</b>					
	WINDOW	Trasparente <b>TR9M</b>	Trasparente fumé <b>FT8P</b>	Stop-sol <b>ST6P</b>	Specchio <b>SP7L</b>				
			Specify the color of the aluminum frame						
			Alluminio <b>AL1A</b>		Titan grey <b>TG7H</b>				

Walk-in wardrobes

Walk-in wardrobes - technical information	216
OPTIONAL for walk-in wardrobes	218
Made-to-measure gaps for walk-in wardrobe	220
SMALL walk-in wardrobes Dpt 56.3 - W 98.7 x 98.7	222
BIG walk-in wardrobes Dpt 56.3 - W 119.9 x 119.9	224
LARGE walk-in wardrobes Dpt 56.3 - W 98.7 x 140.5	226
LARGE walk-in wardrobes Dpt 56.3 - W 98.7 x 150.5	228
Accessories for walk-in wardrobes	230
SMALL walk-in wardrobe with the universal gap	232
BIG walk-in wardrobe with the universal gap	233
LARGE walk-in wardrobe W 140.5 with the universal gap	234
LARGE walk-in wardrobe W 150.5 with the universal gap	235
Accessories for walk-in wardrobes with the universal gap	236



# Walk-in wardrobes - technical information

SMALL walk-in wardrobe 98.7 x 98.7

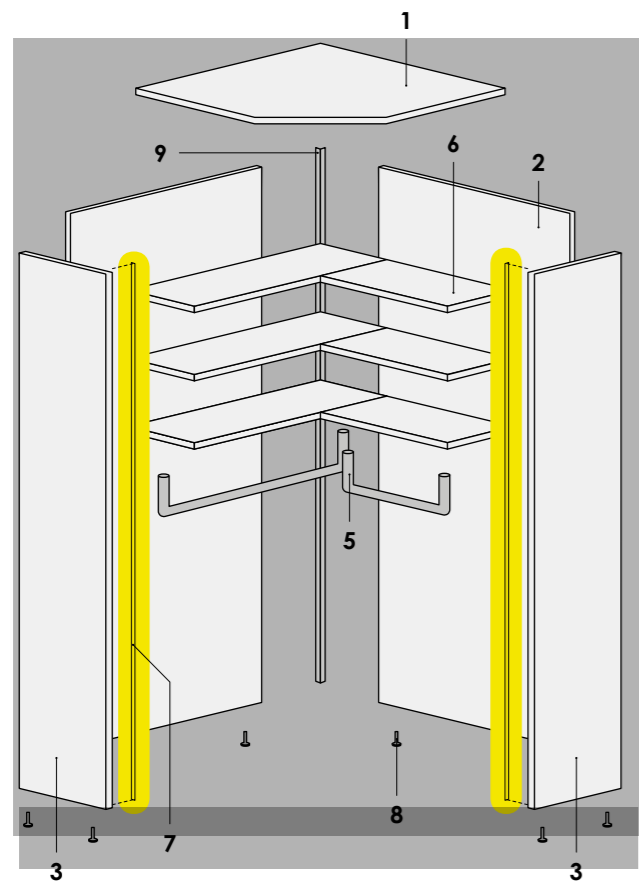

BIG walk-in wardrobe 119.9 x 119.9

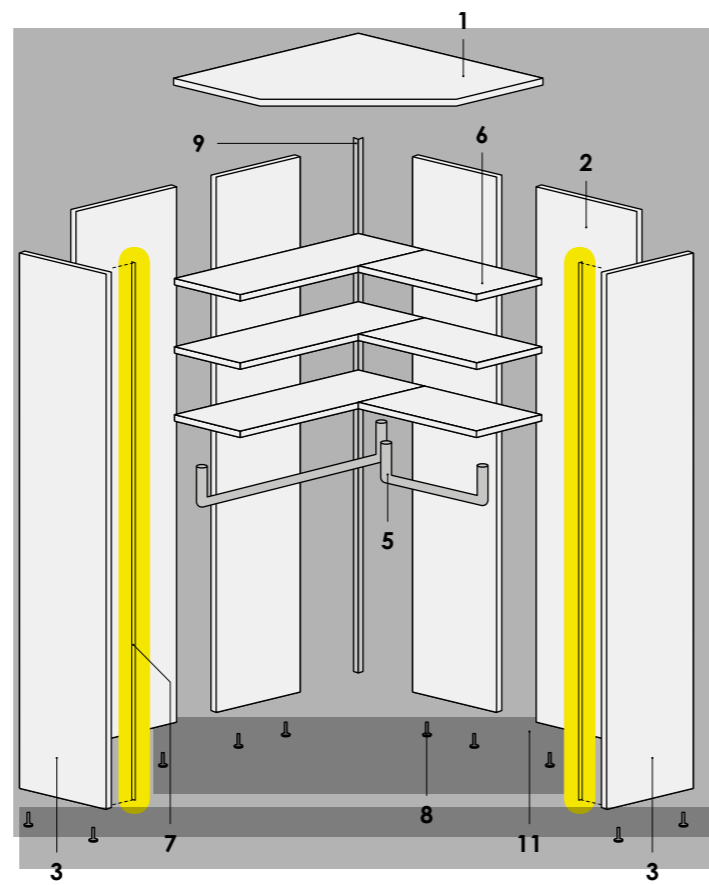

LARGE walk-in wardrobe 98.7 x 140.5/150.5

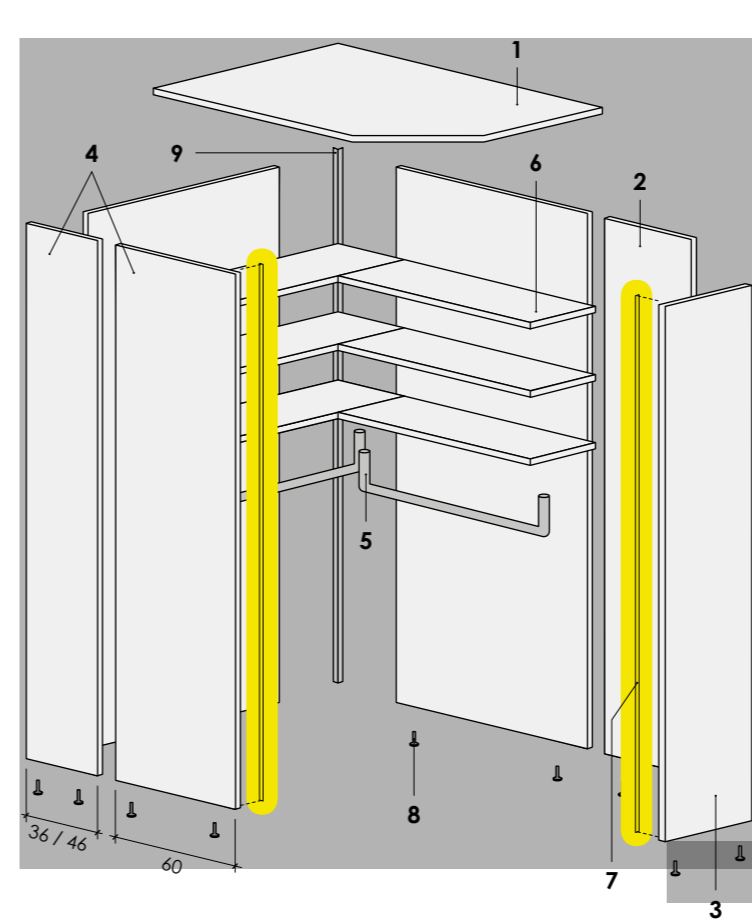

Components:

- 1 Top panel Th 1.8 - With eccentric pin system
- 2 Back panel Th 1.8
- 3 Side panel Th 1.8 Dpt 56.3 - With prefitted hardware.
- 4 Side panel Th 1.8 Dpt 96/106 (2 pieces) - With prefitted hardware.
- 5 BASIC clothes hanging bar in chromed metal PLUS clothes hanging bar (optional) in aluminum.
- 6 Movable shelf Th 2.5 Dpt 41.7 - On runner.
- 7 Strip led (optional) - In full height milled groove.
- 8 Adjustable middle-support feet
- 9 Metal back retainer

- They are equipped with adjustable feet.
- The doors are fitted with decelerated hinges.
- They have no bottom panel.
- They cannot be fitted with doors with a lock.
- **For custom cuts consult the relevant chapter.**

### IMPORTANT!

- We recommend using the SMALL walk-in wardrobe together with a wardrobe or another unit on both sides of it that will make it more stable.
- You can juxtapose to walk-in wardrobes only elements that have the same or lower depth compared to the walk-in wardrobe side panel (see examples **A**).
- For wardrobes W 45 or W 60 alongside the walk-in, these must be positioned with the hinges facing the walk-in (see example **B**).
- Walk-in wardrobes with pairs of CLUB doors are provided only with one handle. Upon customer's request the CLUB handle can be mounted on both doors.

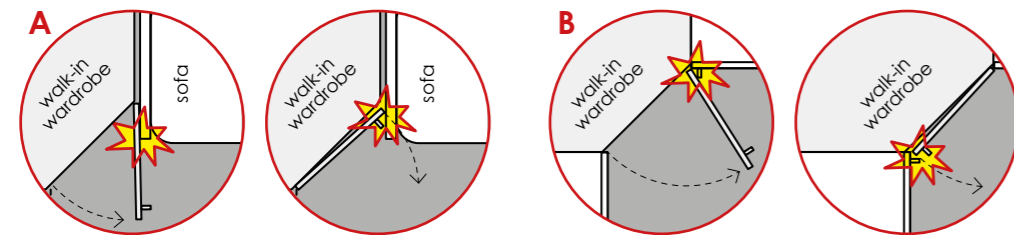

### Use examples for LARGE walk-in wardrobes (Drawing RH)

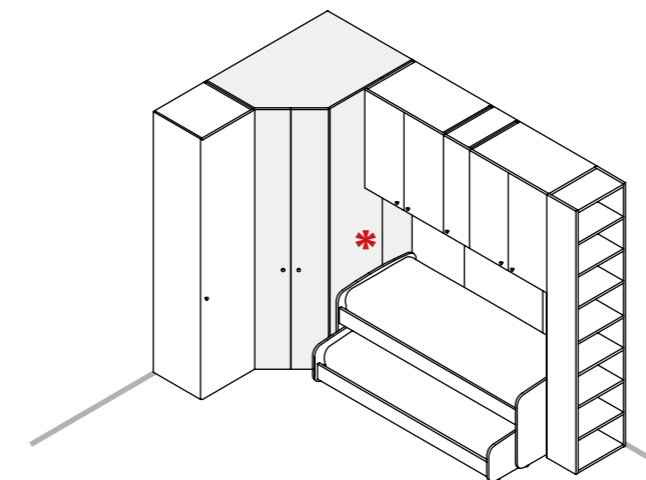

- \* If an overhead structure with rear overhead panels is positioned alongside the LARGE Walk-in, the effective depth of the under-overhead compartment is obtained by subtracting 4 cm. from the total depth. Example: in the LARGE Walk-in measuring 98.7 x 140.5 the effective depth of the walk-in side panel is  $96 - 4 = 92$  cm.

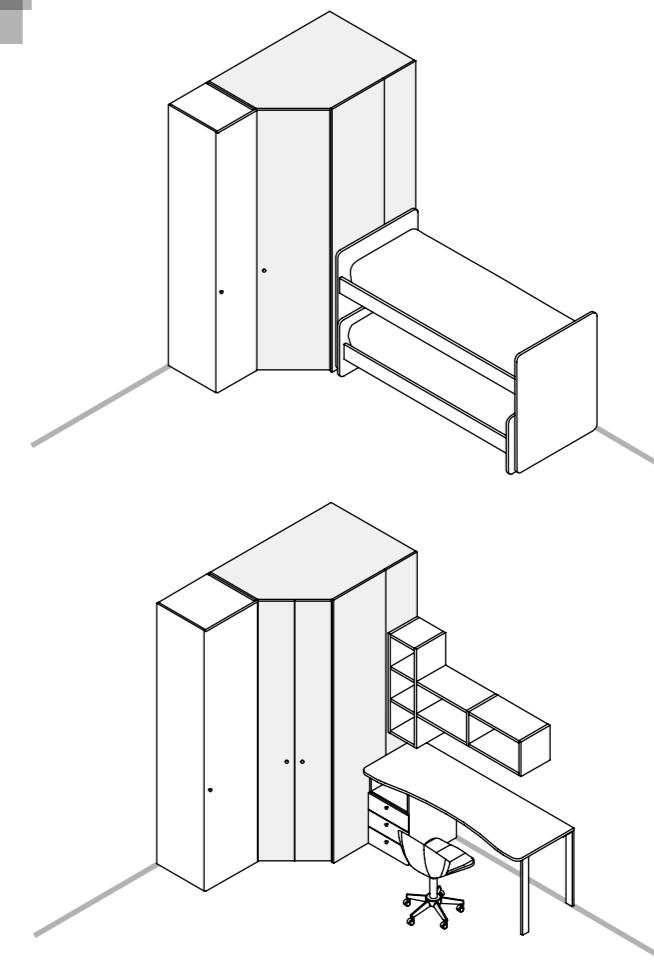

# OPTIONAL for walk-in wardrobes

SMALL walk-in wardrobe

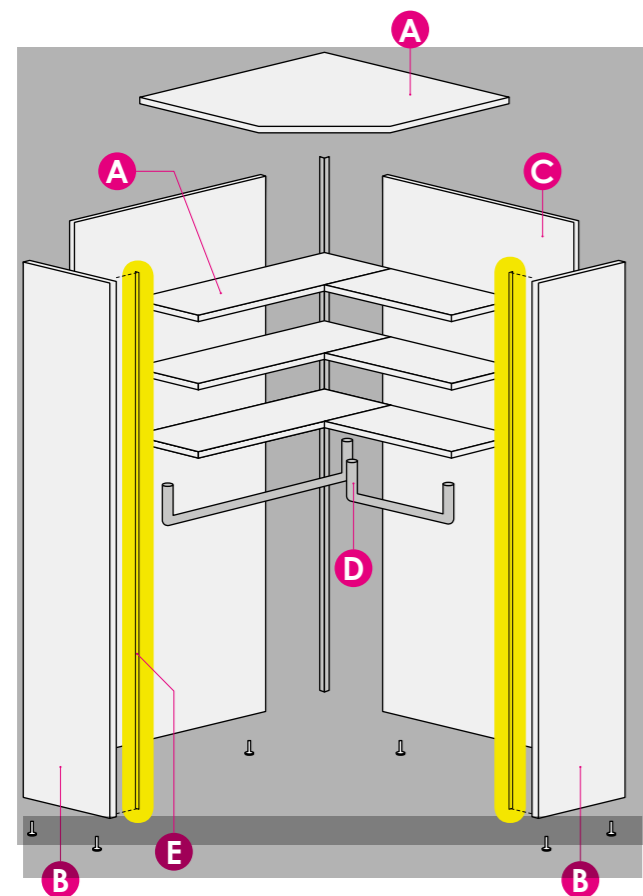

## B Extra colors for Side panels

In addition to the standard CARCASE colors, the side panels are available in all the GROUP 2 colors with surcharge (see table).  
 • **When placing the order:** indicate the colour of the side panels in the COLOURED FINISHES variant in Metron 4.

Side panels	Surcharge for couple side panels (CARCASE colors excluded)
Ht 193,6	
Ht 225,6	
Ht 241,6	
Ht 257,6	

BIG walk-in wardrobe

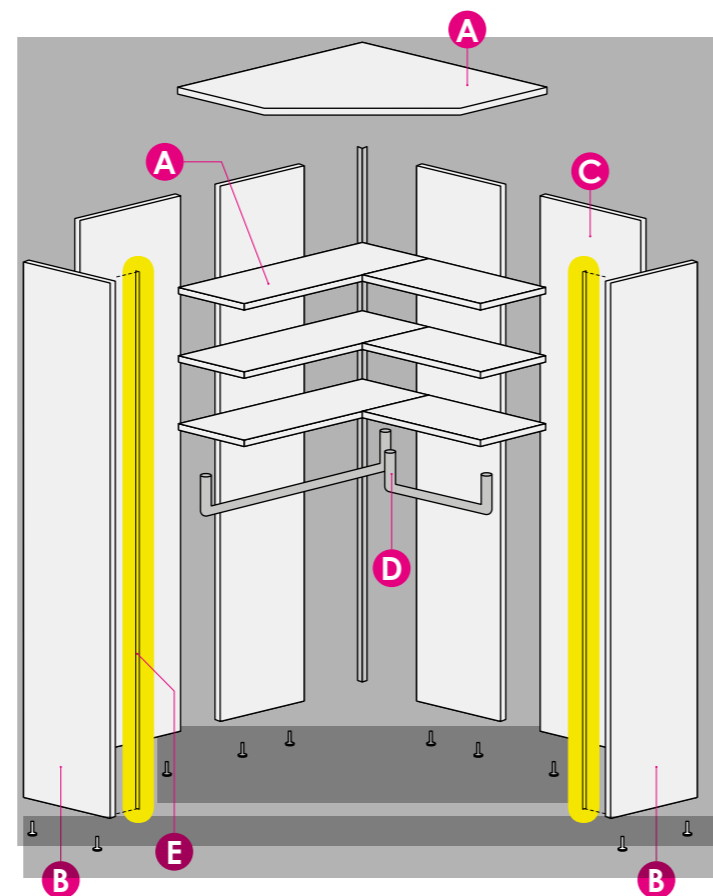

## C Extra colors for Back panels

In addition to the standard CARCASE colors, the back panels are available in all the GROUP 2 colors with surcharge (see table).  
 • **When placing the order:** indicate the colour of the back panels in the BACK PANEL COLOUR variant in Metron 4.

Back panels	Surcharge for single element (CARCASE colors excluded)
	Ht 193,6 - 225,6 - 241,6 - 257,6
SMALL	
BIG	
LARGE	

LARGE walk-in wardrobe

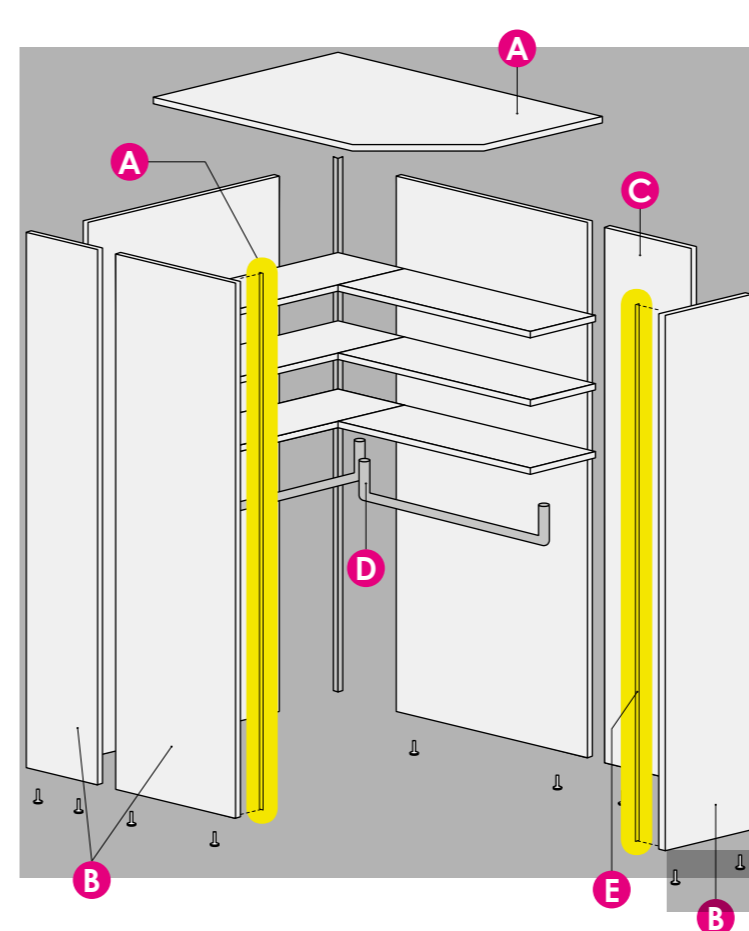

## D PLUS clothes-hanging bar

On request the walk-ins can be equipped with PLUS clothes-hanging bars with surcharge (see table). The PLUS clothes-hanging bar is in aluminium Ø 2,8, available in the Alluminio (AL1A) and Grigio titanio (GZ8T) colors.  
 • **When placing the order:** indicate PLUS clothes-hanging bar in the BAR TYPE variant and the colour in the BAR COLOUR variant in Metron 4.



Clothes-hanging bars	Surcharge for single element
W 77,5 SMALL end LARGE	
W 46,7 SMALL	
W 108,7 BIG	
W 70 BIG	

## A Extra colors for Top panel and Shelves

In addition to the standard CARCASE colors, these components are all available in the GROUP 2 colors with surcharge (see table).  
 • **When placing the order:** indicate the colour in the HORIZONTAL FINISHES variant in Metron 4: the top panel and shelves will automatically be delivered in that colour (if specified, the various elements can be coloured as preferred).  
 • **N.B.** The surcharge is applied to each single component.

Top panel Shelf	Surcharge for single element (CARCASE colors excluded)
SMALL top panel	
BIG top panel	
LARGE top panel	
SMALL and LARGE shelf W 90,1	
BIG shelf W 114,7	
SMALL corner shelves	
BIG corner shelves	
LARGE corner shelves	

## E Side panels with led lighting

On request the side panels can be equipped with led lighting, with surcharge (see table). Lighting consists in a full-height led strip inset into the side panel.  
 • **When placing the order:** indicate LIGHT ON BOTH SIDES in the SIDE PANEL LIGHTING variant in Metron 4.



Led side panels	Surcharge couple side panels 2 led strips + 1 sensor + 1 power supply
Ht 193,6	
Ht 225,6	
Ht 241,6	
Ht 257,6	

# Made-to-measure gaps for walk-in wardrobe

## SMALL walk-in wardrobe

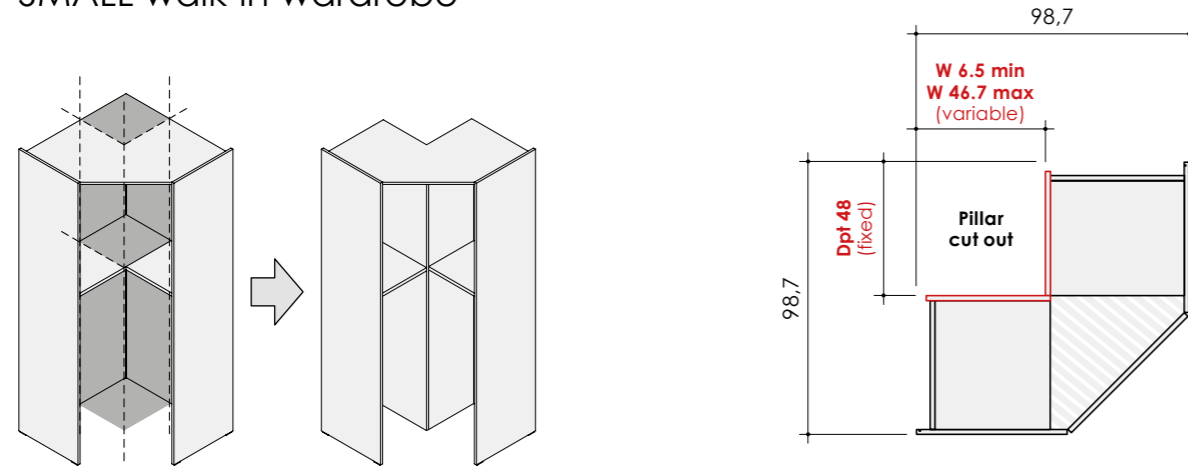

**POSSIBLE CUTS:**

- All SMALL walk-in wardrobes with universal gap

65 mm : Minimum gap width  
467 mm : Maximum gap width

## Left LARGE walk-in wardrobe

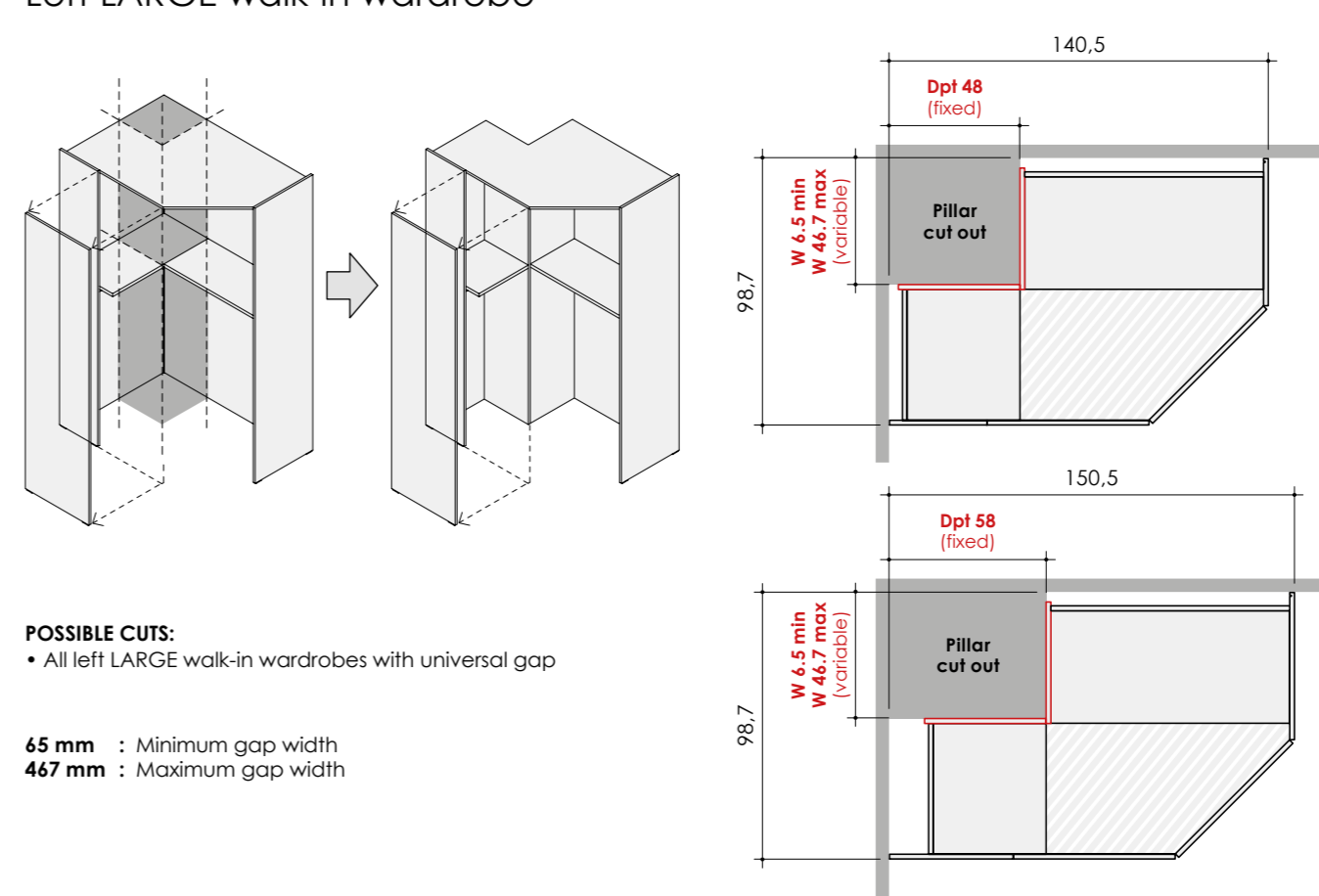

**POSSIBLE CUTS:**

- All left LARGE walk-in wardrobes with universal gap

65 mm : Minimum gap width  
467 mm : Maximum gap width

## BIG walk-in wardrobe

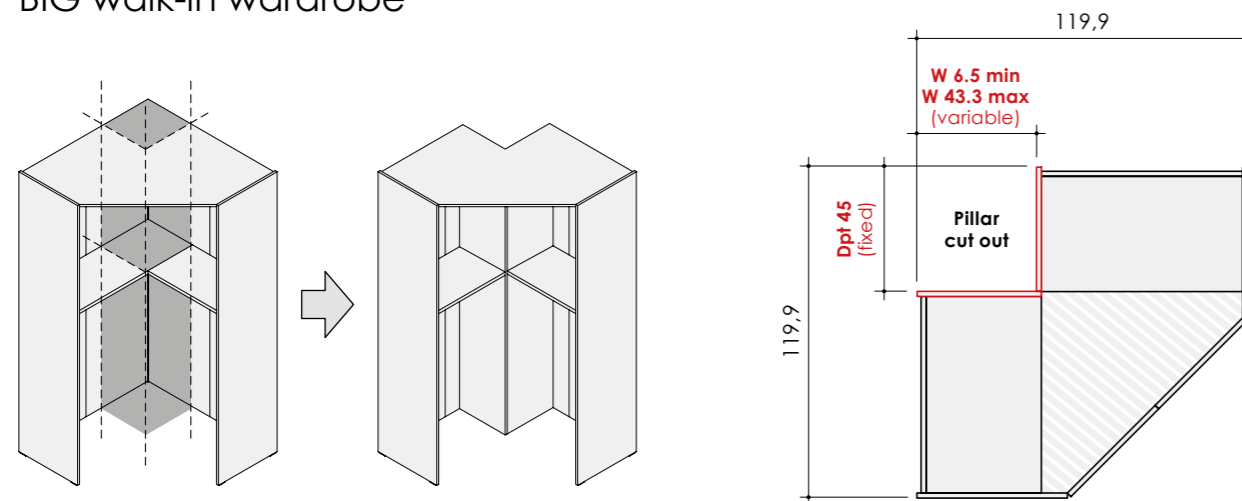

**POSSIBLE CUTS:**

- All BIG walk-in wardrobes with universal gap

65 mm : Minimum gap width  
432 mm : Maximum gap width

## Right LARGE walk-in wardrobe

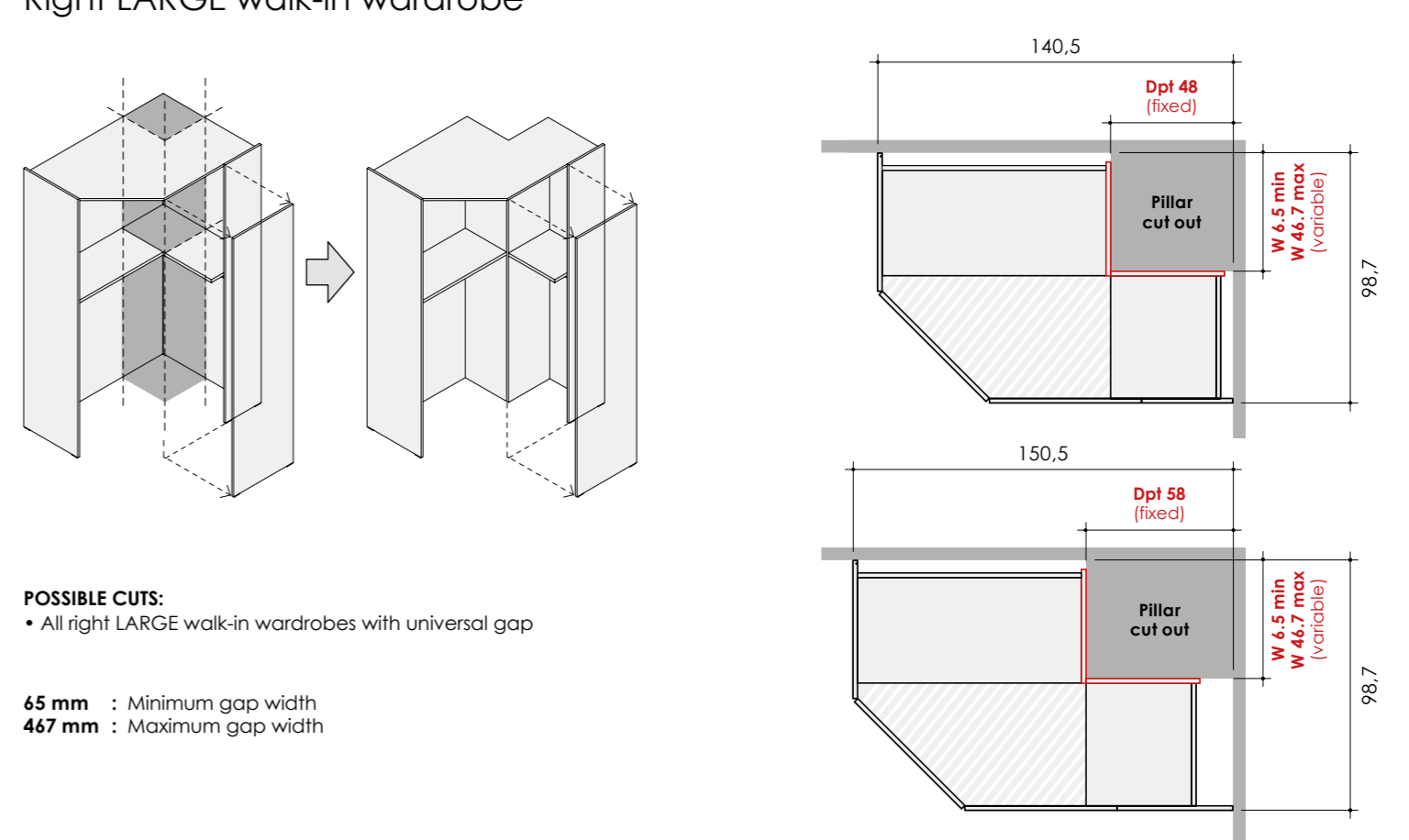

**POSSIBLE CUTS:**

- All right LARGE walk-in wardrobes with universal gap

65 mm : Minimum gap width  
467 mm : Maximum gap width

**For made-to-measure gap:**

- Always start with the universal gap Walk-in wardrobe code and set the gap size of the pillar.
- To add shelves, they must be indicated with a drawing inside the Walk-in wardrobes.



# SMALL walk-in wardrobes Dpt 56.3 - W 98.7 x 98.7

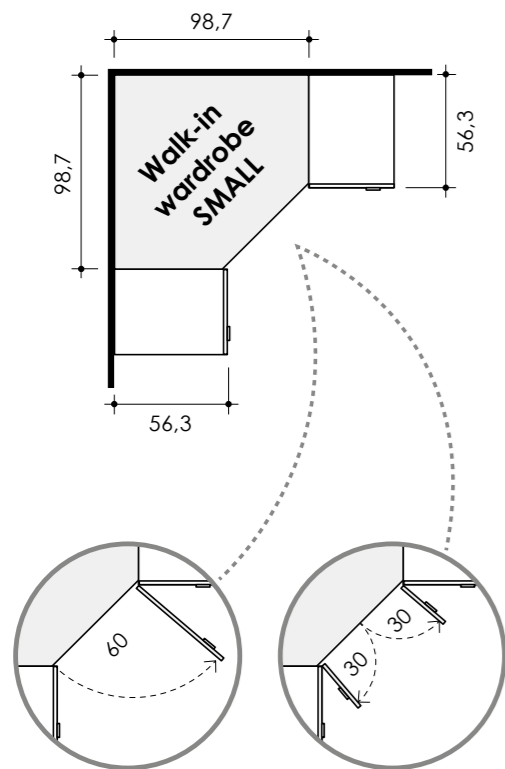

• Version with 1 whole door W 60 with 45° hinges supplied at the base unit of dust catcher brush. **105° opening.** The side panel opposite the one with mounting plates has a vertical dust catcher.

• Version with 2 whole doors W 30 with 45° hinges supplied at the base unit of dust catcher brush. **105° opening.** The L door is fitted with a vertical dust catcher.

## Ht 193.6

Specify hinge R or L

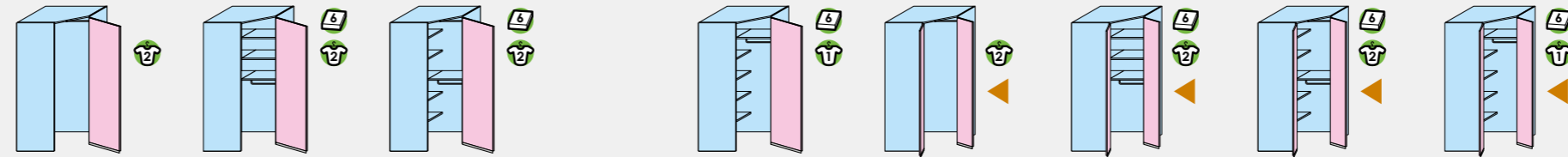

Code	PK21.00T	PK21.01Z	PK21.02F	PK21.03N	PK21.04U	PK21.05A	PK21.06G	PK21.07P		
ONE	matte									
	glossy									
CLUB										
WINDOW										

## Ht 225.6

Specify hinge R or L

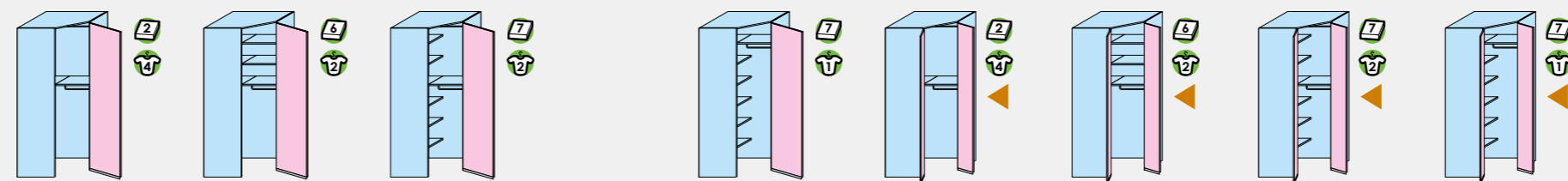

Code	PK21.08V	PK21.09B	PK21.10Y	PK21.11E	PK21.12M	PK21.13T	PK21.14Z	PK21.15F		
ONE	matte									
	glossy									
CLUB										
WINDOW										

## Ht 241.6

Specify hinge R or L

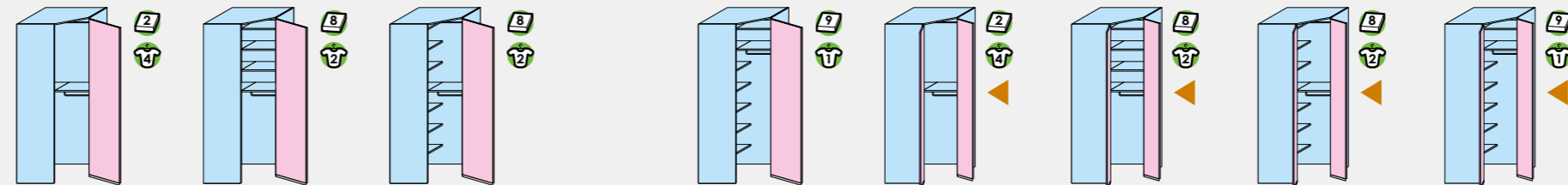

Code	PK22.43P	PK22.44V	PK22.45B	PK22.46H	PK22.47Q	PK22.48W	PK22.49C	PK22.50Z		
ONE	matte									
	glossy									
CLUB										
WINDOW										

## Ht 257.6

Specify hinge R or L

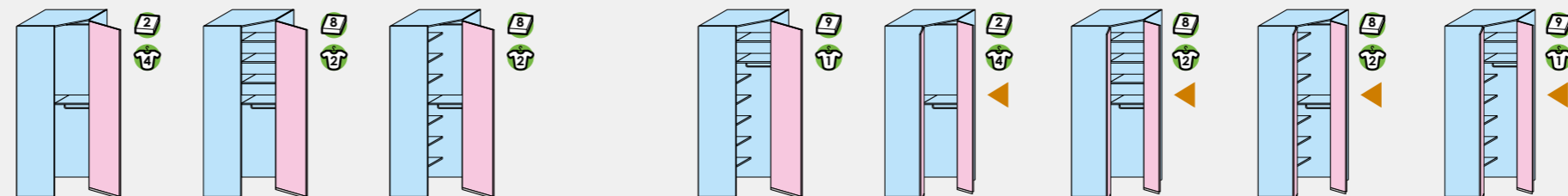

Code	PK21.16N	PK21.17U	PK21.18A	PK21.19G	PK21.20D	PK21.21L	PK21.22S	PK21.23Y		
ONE	matte									
	glossy									
CLUB										
WINDOW										

Components in **GROUP 2 colors**  
 Components in **Types and colors FRONT**

**Inside shelves:** The number indicates the quantity.  
**Clothes hanging bars:** The number indicates the quantity.  
**With doors W 30**



**OPTIONAL:**  
p. 218

- A · Extra colors for Top panel and Shelves
- B · Extra colors for Side panels
- C · Extra colors for Back panels
- D · PLUS clothes rail
- E · Side panels with led lighting



p. 56 Knob and handle positions  
 p. 230 Accessories for walk-in wardrobes

# BIG walk-in wardrobes Dpt 56.3 - W 119.9 x 119.9

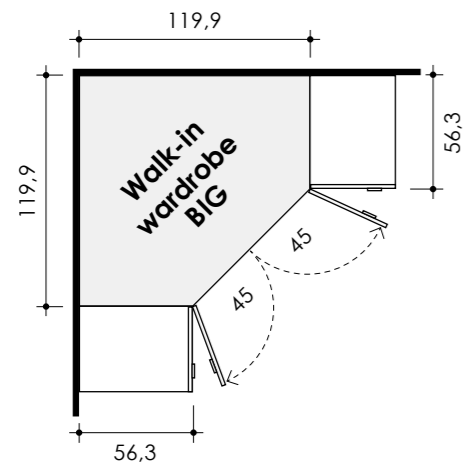

• They have 2 whole doors W 45 with 45° hinges supplied at the base unit of dust catcher brush. **105° opening**. The L door is fitted with a vertical dust catcher.

## Ht 193.6

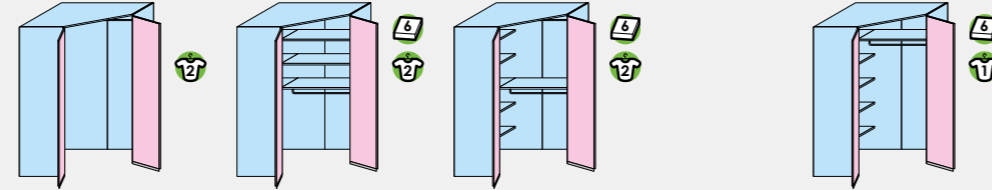

Code	PK21.24E	PK21.25M	PK21.26T	PK21.27Z						
ONE	matte									
	glossy									
CLUB										
WINDOW										

## Ht 225.6

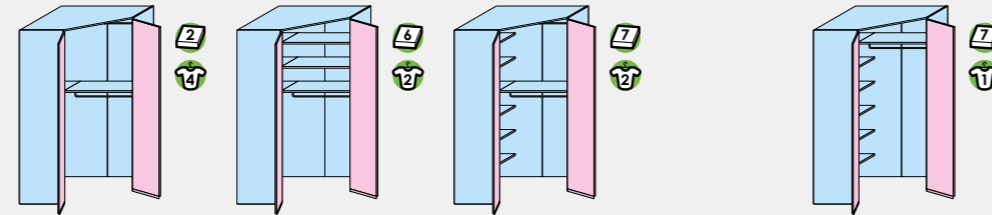

Code	PK21.28F	PK21.29N	PK21.30K	PK21.31R						
ONE	matte									
	glossy									
CLUB										
WINDOW										

## Ht 241.6

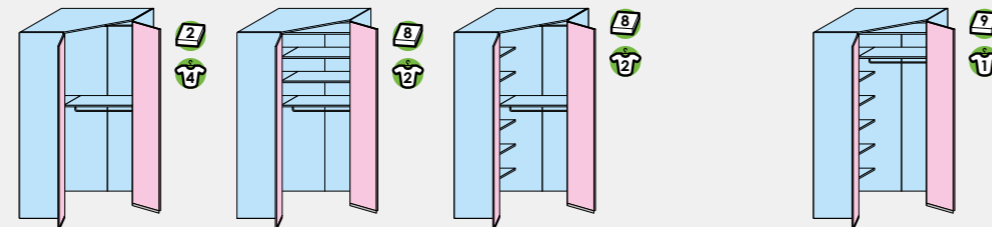

Code	PK22.51F	PK22.52N	PK22.53U	PK22.54A						
ONE	matte									
	glossy									
CLUB										
WINDOW										

## Ht 257.6

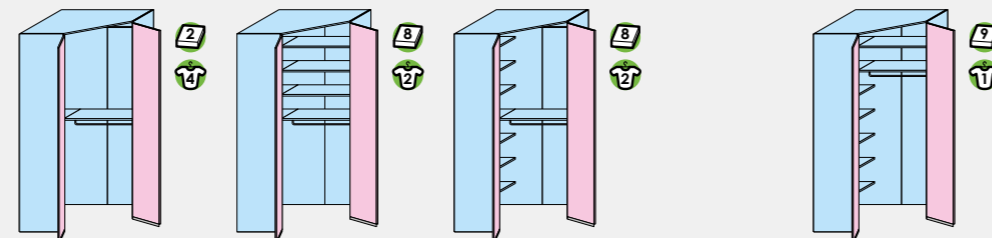

Code	PK21.32X	PK21.33D	PK21.34L	PK21.35S						
ONE	matte									
	glossy									
CLUB										
WINDOW										

Components in **GROUP 2 colors**  
 Components in **Types and colors FRONT**

**Inside shelves:** The number indicates the quantity.  
**Clothes hanging bars:** The number indicates the quantity.



**OPTIONAL:** p. 218  
**A** · Extra colors for Top panel and Shelves  
**B** · Extra colors for Side panels  
**C** · Extra colors for Back panels  
**D** · PLUS clothes rail  
**E** · Side panels with led lighting



p. 56 Knob and handle positions  
 p. 230 Accessories for walk-in wardrobes

# LARGE walk-in wardrobes Dpt 56.3 - W 98.7 x 140.5

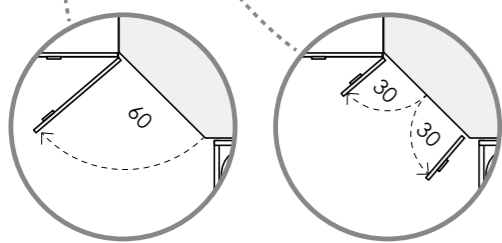
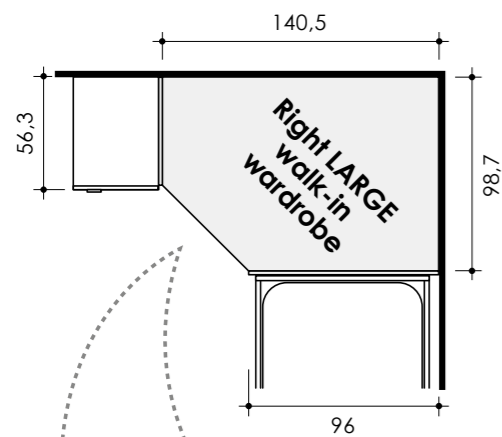
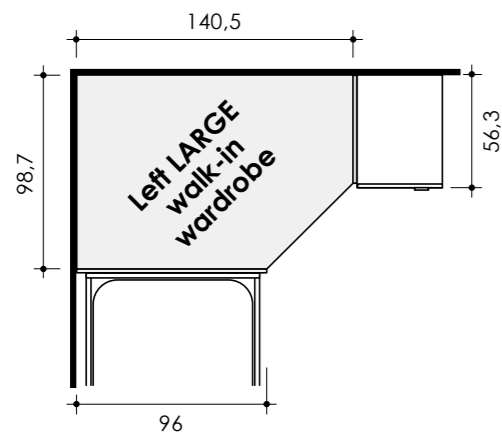

- Version with 1 whole door W 60 with 45° hinges supplied at the base unit of dust catcher brush. **105° opening.** The side panel opposite the one with mounting plates has a vertical dust catcher.
- Version with 2 whole doors W 30 with 45° hinges supplied at the base unit of dust catcher brush. **105° opening.** The L door is fitted with a vertical dust catcher.

## Ht 225.6

Specify hinge R or L

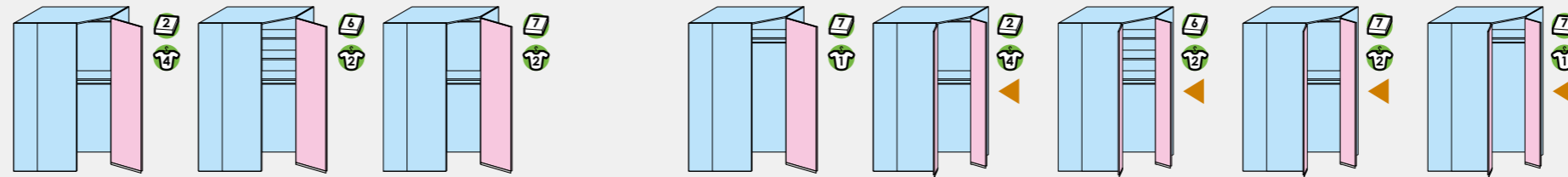

Code	L	PK21.36Y	PK21.37E	PK21.38M	PK21.39T	PK21.40Q	PK21.41W	PK21.42C	PK21.43K		
	R	PK21.52H	PK21.53Q	PK21.54W	PK21.55C	PK21.56K	PK21.57R	PK21.58X	PK21.59D		
ONE	matte										
	glossy										
CLUB											
WINDOW											

## Ht 241.6

Specify hinge R or L

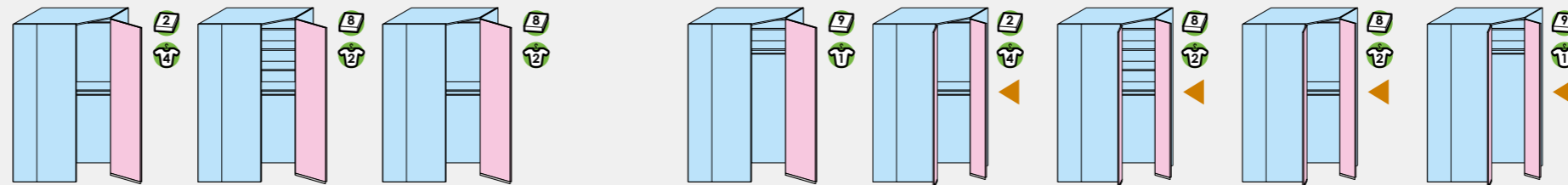

Code	L	PK22.55G	PK22.56P	PK22.57V	PK22.58B	PK22.59H	PK22.60E	PK22.61M	PK22.62T		
	R	PK22.63Z	PK22.64F	PK22.65N	PK22.66U	PK22.67A	PK22.68G	PK22.69P	PK22.70L		
ONE	matte										
	glossy										
CLUB											
WINDOW											

## Ht 257.6

Specify hinge R or L

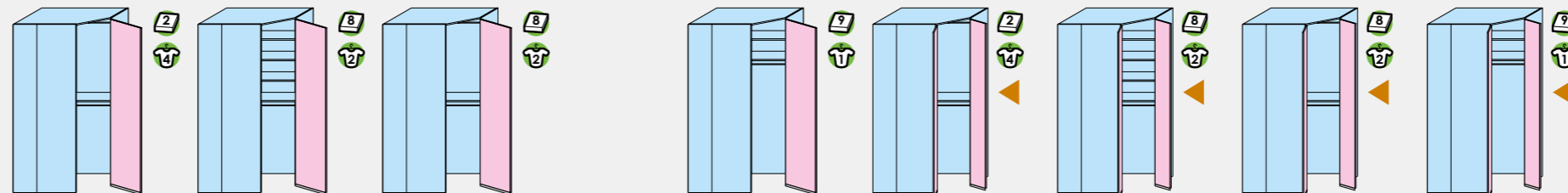

Code	L	PK21.44R	PK21.45X	PK21.46D	PK21.47L	PK21.48S	PK21.49Y	PK21.50V	PK21.51B		
	R	PK21.60A	PK21.61G	PK21.62P	PK21.63V	PK21.64B	PK21.65H	PK21.66Q	PK21.67W		
ONE	matte										
	glossy										
CLUB											
WINDOW											

- Components in **GROUP 2 colors**
- Components in **Types and colors FRONT**

- Inside shelves:** The number indicates the quantity.
- Clothes hanging bars:** The number indicates the quantity.
- With doors W 30**



- OPTIONAL:** p. 218
- A · Extra colors for Top panel and Shelves
  - B · Extra colors for Side panels
  - C · Extra colors for Back panels
  - D · PLUS clothes rail
  - E · Side panels with led lighting



- p. 56 Knob and handle positions  
p. 230 Accessories for walk-in wardrobes



# LARGE walk-in wardrobes Dpt 56.3 - W 98.7 x 150.5

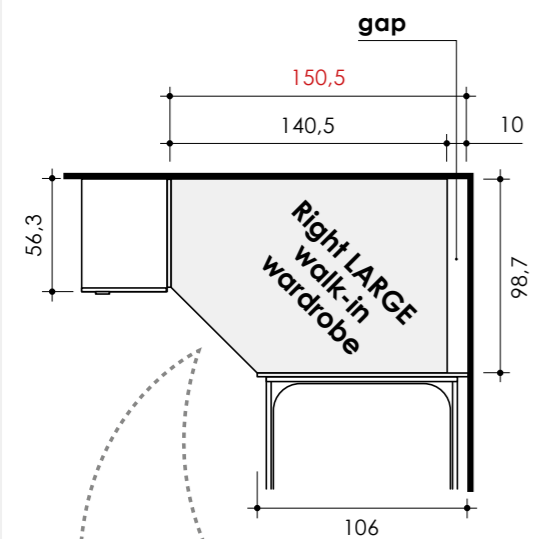
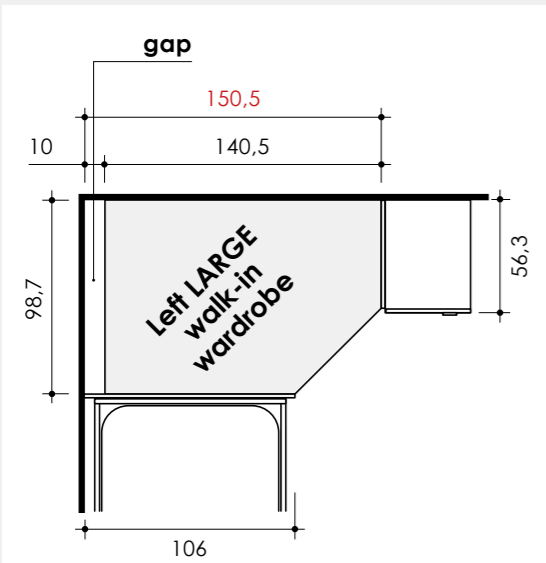

- Version with 1 whole door W 60 with 45° hinges supplied at the base unit of dust catcher brush. **105° opening.** The side panel opposite the one with mounting plates has a vertical dust catcher.
- Version with 2 whole doors W 30 with 45° hinges supplied at the base unit of dust catcher brush. **105° opening.** The L door is fitted with a vertical dust catcher.

## Ht 225.6

Specify hinge R or L

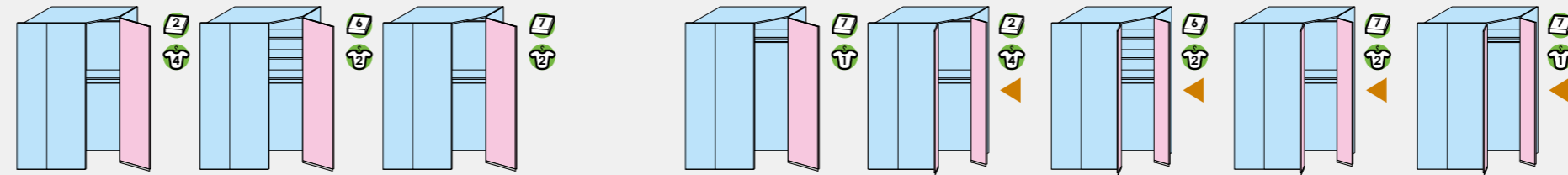

Code	L	PK21.68C	PK21.69K	PK21.70F	PK21.71N	PK21.72U	PK21.73A	PK21.74G	PK21.75P		
	R	PK21.84N	PK21.85U	PK21.86A	PK21.87G	PK21.88P	PK21.89V	PK21.90S	PK21.91Y		
ONE	matte										
	glossy										
CLUB											
WINDOW											

## Ht 241.6

Specify hinge R or L

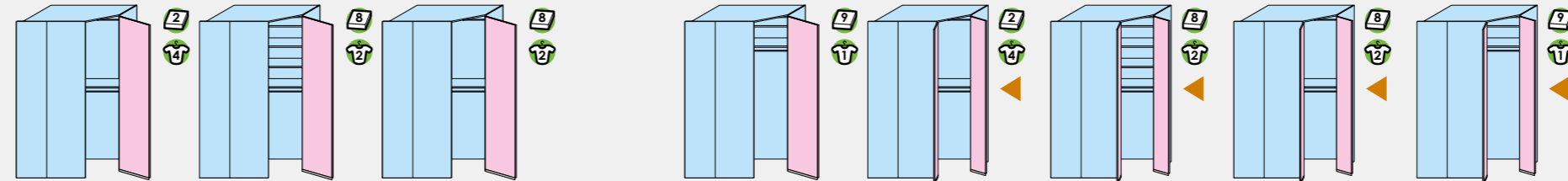

Code	L	PK22.71S	PK22.72Y	PK22.73E	PK22.74M	PK22.75T	PK22.76Z	PK22.77F	PK22.78N		
	R	PK22.79U	PK22.80R	PK22.81X	PK22.82D	PK22.83L	PK22.84S	PK22.85Y	PK22.86E		
ONE	matte										
	glossy										
CLUB											
WINDOW											

## Ht 257.6

Specify hinge R or L

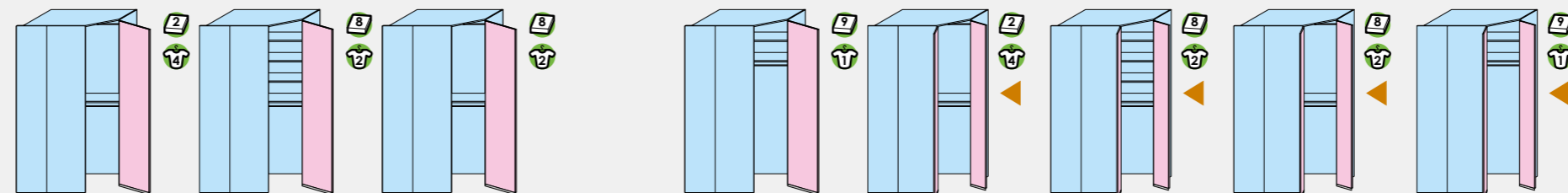

Code	L	PK21.76V	PK21.77B	PK21.78H	PK21.79Q	PK21.80M	PK21.81T	PK21.82Z	PK21.83F		
	R	PK21.92E	PK21.93M	PK21.94T	PK21.95Z	PK21.96F	PK21.97N	PK21.98U	PK21.99A		
ONE	matte										
	glossy										
CLUB											
WINDOW											

- Components in **GROUP 2 colors**
- Components in **Types and colors FRONT**

- Inside shelves:** The number indicates the quantity.
- Clothes hanging bars:** The number indicates the quantity.
- With doors W 30**











**OPTIONAL:**  
p. 218

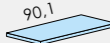
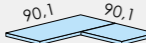

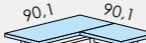

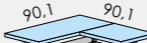



- A · Extra colors for Top panel and Shelves
- B · Extra colors for Side panels
- C · Extra colors for Back panels
- D · PLUS clothes rail
- E · Side panels with led lighting

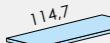



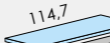



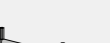

p. 56 Knob and handle positions  
p. 230 Accessories for walk-in wardrobes

# Accessories for walk-in wardrobes

<b>SMALL</b>	<b>Movable shelves</b>		<b>Movable shelves with BASIC clothes hanging bars</b>		<b>Movable shelves with PLUS clothes hanging bars</b>		<b>BASIC clothes-hanging bars</b>		<b>PLUS clothes-hanging bars</b>					
	<b>Long</b> Dpt 41,7 Th 2,5	<b>Corner</b> Dpt 41,7 Th 2,5	<b>Long</b> Dpt 41,7 Th 2,5	<b>Corner</b> Dpt 41,7 Th 2,5	<b>Long</b> Dpt 41,7 Th 2,5	<b>Corner</b> Dpt 41,7 Th 2,5	<b>Long</b> W 77,5	<b>Short</b> W 46,7	<b>Long</b> W 77,5	<b>Short</b> W 46,7				
														
<b>Code</b>	<b>P08.50N</b>	<b>P08.51T</b>	<b>P08.52Y</b>	<b>P08.53D</b>	<b>PK01.52B</b>	<b>PK01.53H</b>	<b>P08.54K</b>	<b>P08.55Q</b>	<b>PK01.54Q</b>	<b>PK01.55W</b>				
	*													

<b>BIG</b>	<b>Movable shelves</b>		<b>Movable shelves with BASIC clothes hanging bars</b>		<b>Movable shelves with PLUS clothes hanging bars</b>		<b>BASIC clothes-hanging bars</b>		<b>PLUS clothes-hanging bars</b>					
	<b>Long</b> Dpt 41,7 Th 2,5	<b>Corner</b> Dpt 41,7 Th 2,5	<b>Long</b> Dpt 41,7 Th 2,5	<b>Corner</b> Dpt 41,7 Th 2,5	<b>Long</b> Dpt 41,7 Th 2,5	<b>Corner</b> Dpt 41,7 Th 2,5	<b>Long</b> W 108,7	<b>Short</b> W 70	<b>Long</b> W 108,7	<b>Short</b> W 70				
														
<b>Code</b>	<b>P08.56V</b>	<b>P08.57A</b>	<b>P08.58F</b>	<b>P08.59M</b>	<b>PK01.56C</b>	<b>PK01.57K</b>	<b>P08.60S</b>	<b>P08.61X</b>	<b>PK01.58R</b>	<b>PK01.59X</b>				
	*													

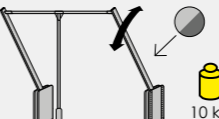
<b>LARGE</b> W 140.5/150.5	<b>Movable shelves</b>		<b>Movable shelves with BASIC clothes hanging bars</b>		<b>Movable shelves with PLUS clothes hanging bars</b>		<b>BASIC clothes hanging bar</b>	<b>PLUS clothes hanging bar</b>	<b>Cantilever clothes rail</b> To be positioned on the side L 98.7				
	Dpt 41,7 Th 2,5	<b>Corner</b> Dpt 41,7 Th 2,5	Dpt 41,7 Th 2,5	<b>Corner</b> Dpt 41,7 Th 2,5	Dpt 41,7 Th 2,5	<b>Corner</b> Dpt 41,7 Th 2,5	W 77,5	W 77,5	Ht 84				
										10 kg			
<b>Code</b>	<b>L P08.62C</b>	<b>P08.63H</b>	<b>P08.64P</b>	<b>P08.65U</b>	<b>PK01.60U</b>	<b>PK01.61A</b>	<b>P08.66Z</b>	<b>PK01.62G</b>	<b>P02.58M</b>				
	<b>R P08.67E</b>	<b>P08.68L</b>	<b>P08.69R</b>	<b>P08.70W</b>	<b>PK01.63P</b>	<b>PK01.64V</b>	<b>P08.66Z</b>	<b>PK01.62G</b>	<b>P02.58M</b>				
	*												

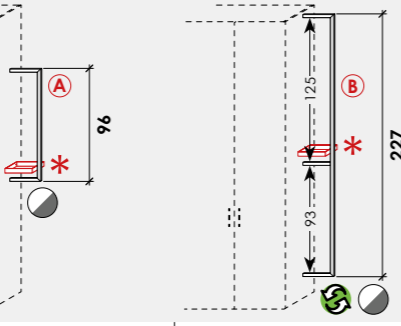
<b>BERNARDO</b> Clothes hangers	Dpt 2		<b>Tray</b>	<b>Metal clothes reacher pole</b>	<b>Lighting with sensor</b> Complete kits with 1 Power pack. Cover color Aluminum and Titanium.								
	W 28					Ht 4	Ht 115	Dpt 19,2					
	<p>Ⓐ 1 for elements Ht 193.6; 1 or 2, at the discretion, for elements Ht 225.6 - 241.6 - 257.6 - 289.6.</p> <p>Ⓑ For elements Ht 241.6 - 257.6 - 289.6.</p> <p>* Tray (optional) positions</p>					Dpt 15		W 11,2					
<b>Code</b>		<b>P07.70T</b>	<b>P08.31K</b>	<b>P08.32Q</b>	<b>PL04.17C</b>	<b>P08.71B</b>							

Components in **GROUP 2 colors**  
AL1A GZ8T

\* Price of the element in the GROUP 2 colors (CARCASE colors excluded)

## SMALL walk-in wardrobe with the universal gap

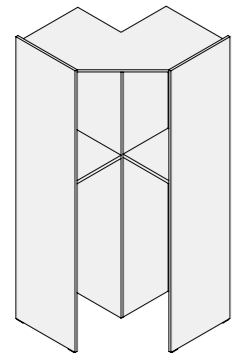

For more information see:  
SMALL walk-in wardrobes  
Dpt 56.3 - W 98.7 x 98.7

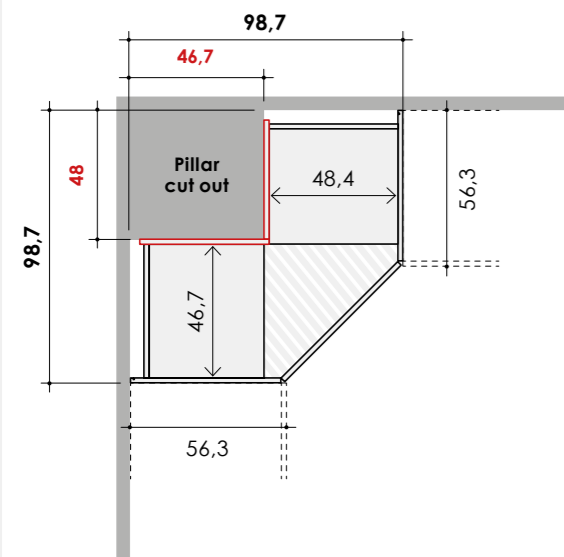

### Ht 193.6

Specify hinge  
R or L

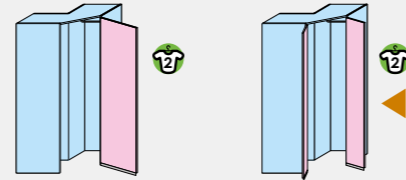

Code	PK22.00X	PK22.01D
ONE	matte	
	glossy	
CLUB		
WINDOW		

### Ht 225.6

Specify hinge  
R or L

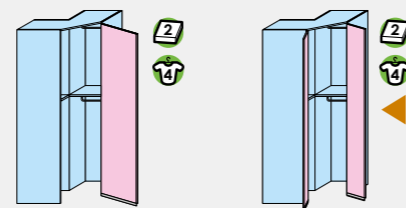

Code	PK22.02L	PK22.03S
ONE	matte	
	glossy	
CLUB		
WINDOW		

### Ht 241.6

Specify hinge  
R or L

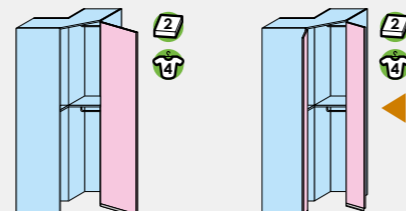

Code	PK22.87M	PK22.88T
ONE	matte	
	glossy	
CLUB		
WINDOW		

### Ht 257.6

Specify hinge  
R or L

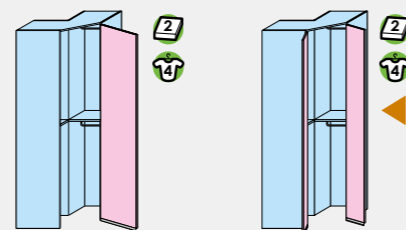

Code	PK22.04Y	PK22.05E
ONE	matte	
	glossy	
CLUB		
WINDOW		

## BIG walk-in wardrobe with the universal gap

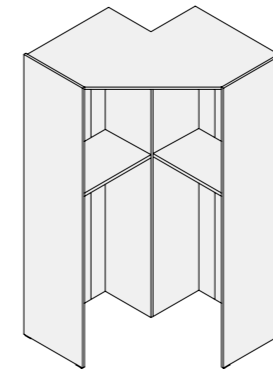

For more information see:  
BIG walk-in wardrobes  
Dpt 56.3 - W 119.9 x 119.9

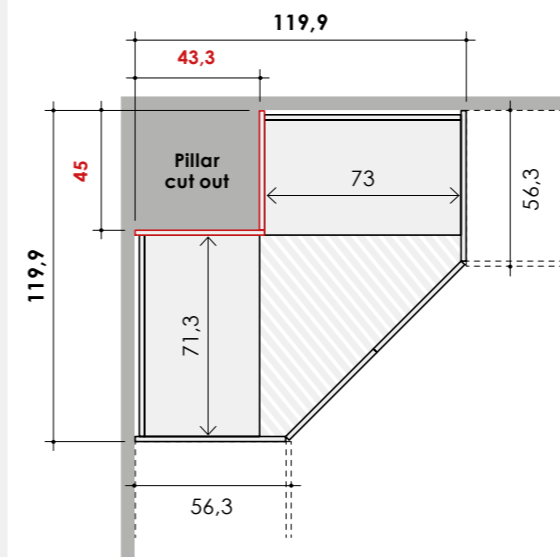

### Ht 193.6

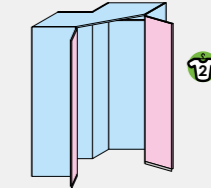

Code	PK22.12R	
ONE	matte	
	glossy	
CLUB		
WINDOW		

### Ht 225.6

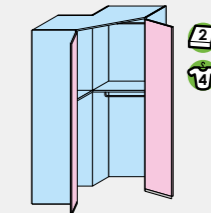

Code	PK22.13X	
ONE	matte	
	glossy	
CLUB		
WINDOW		

### Ht 241.6

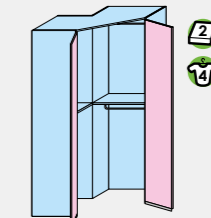

Code	PK22.89Z	
ONE	matte	
	glossy	
CLUB		
WINDOW		

### Ht 257.6

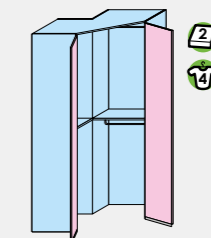

Code	PK22.14D	
ONE	matte	
	glossy	
CLUB		
WINDOW		

Components in **GROUP 2 colors**  
Components in **Types and colors FRONT**

**Inside shelves:** The number indicates the quantity.  
 **Clothes hanging bars:** The number indicates the quantity.  
 **With doors W 30**

**OPTIONAL:** **p. 218**  
A · Extra colors for Top panel and Shelves  
B · Extra colors for Side panels  
C · Extra colors for Back panels  
D · PLUS clothes rail  
E · Side panels with led lighting

**p. 56** Knob and handle positions  
**p. 220** Made-to-measure gaps for walk-in wardrobe  
**p. 236** Accessories for walk-in wardrobes with the universal gap

# LARGE walk-in wardrobe W 140.5 with the universal gap

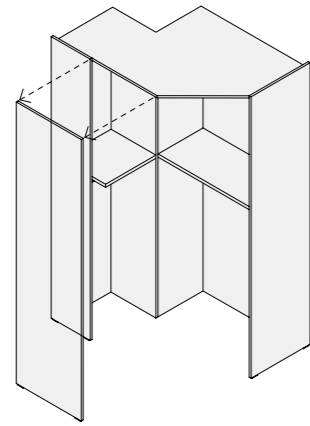

For more information see:  
LARGE walk-in wardrobes  
Dpt 56.3 - W 98.7 x 140.5

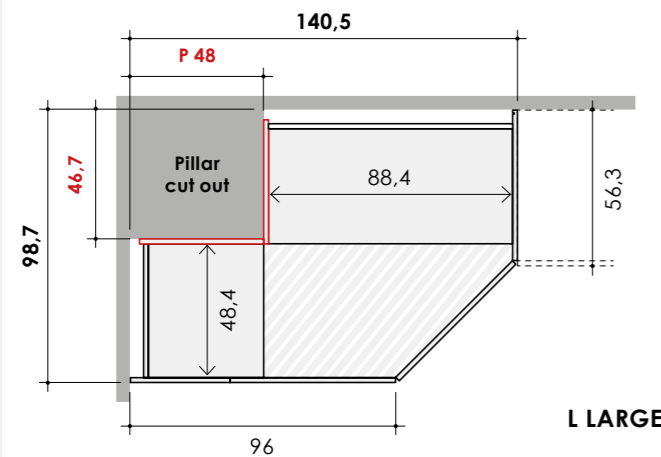

## Ht 225.6

Specify hinge  
R or L

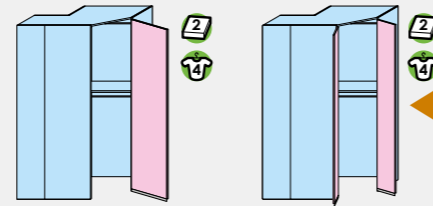

Code	L	PK22.21Q	PK22.22W
	R	PK22.35W	PK22.36C
ONE	matte		
	glossy		
CLUB			
WINDOW			

## Ht 241.6

Specify hinge  
R or L

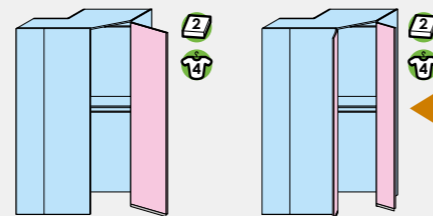

Code	L	PK22.90W	PK22.91C
	R	PK22.92K	PK22.93R
ONE	matte		
	glossy		
CLUB			
WINDOW			

## Ht 257.6

Specify hinge  
R or L

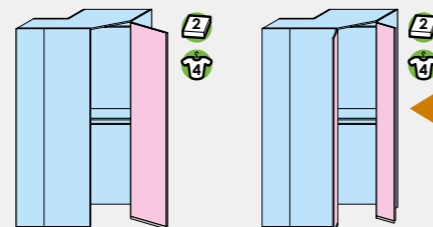

Code	L	PK22.23C	PK22.24K
	R	PK22.37K	PK22.38R
ONE	matte		
	glossy		
CLUB			
WINDOW			

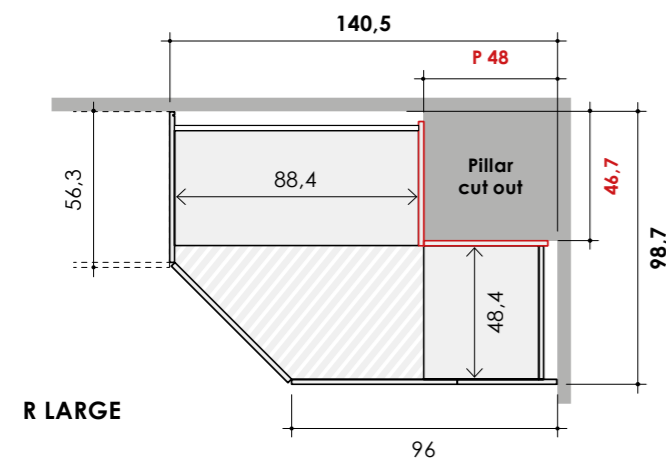

Components in **GROUP 2** colors  
 Components in **Types and colors FRONT**

**Inside shelves:** The number indicates the quantity.  
 **Clothes hanging bars:** The number indicates the quantity.  
 **With doors W 30**

# LARGE walk-in wardrobe W 150.5 with the universal gap

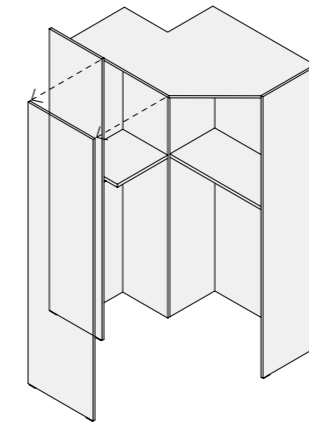

For more information see:  
LARGE walk-in wardrobes  
Dpt 56.3 - W 98.7 x 150.5

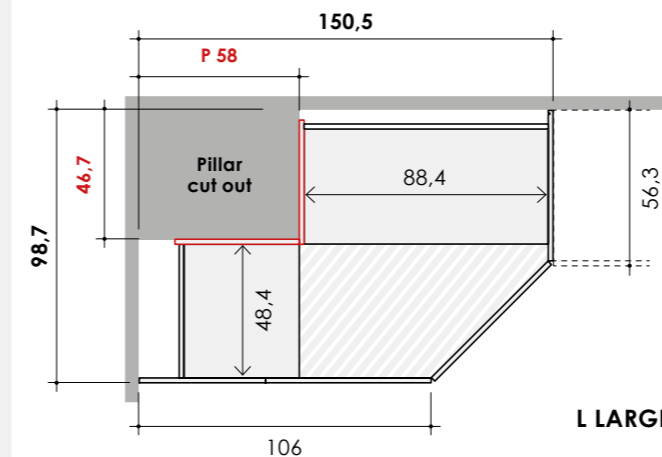

## Ht 225.6

Specify hinge  
R or L

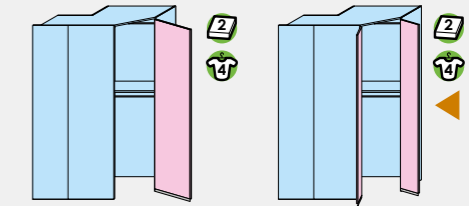

Code	L	PK22.25R	PK22.26X
	R	PK22.39X	PK22.40U
ONE	matte		
	glossy		
CLUB			
WINDOW			

## Ht 241.6

Specify hinge  
R or L

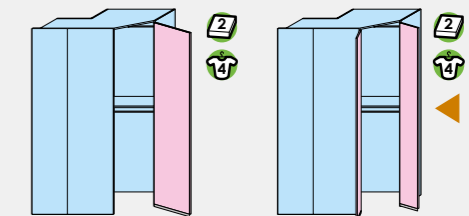

Code	L	PK22.94X	PK22.95D
	R	PK22.96L	PK22.97S
ONE	matte		
	glossy		
CLUB			
WINDOW			

## Ht 257.6

Specify hinge  
R or L

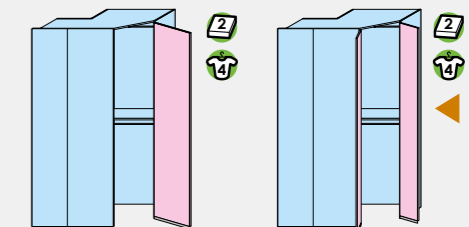

Code	L	PK22.27D	PK22.28L
	R	PK22.41A	PK22.42G
ONE	matte		
	glossy		
CLUB			
WINDOW			

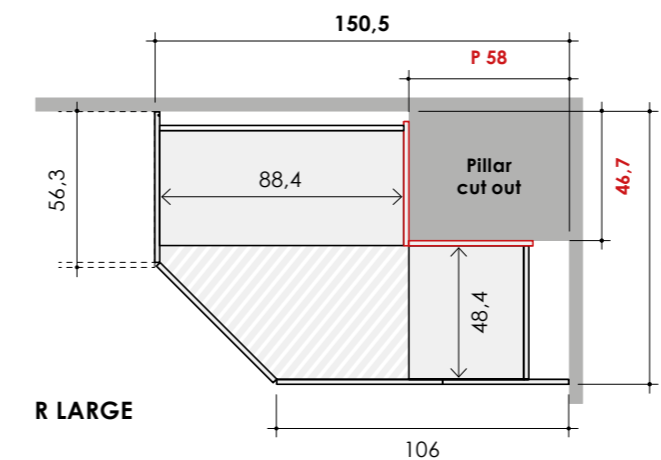









**OPTIONAL:**  
**p. 218**  
A · Extra colors for Top panel and Shelves  
B · Extra colors for Side panels  
C · Extra colors for Back panels  
D · PLUS clothes rail  
E · Side panels with led lighting











**p. 56** Knob and handle positions  
**p. 220** Made-to-measure gaps for walk-in wardrobe  
**p. 236** Accessories for walk-in wardrobes with the universal gap

# Accessories for walk-in wardrobes with the universal gap

## SMALL











	Movable shelves		Movable shelves with BASIC clothes hanging bars		Movable shelves with PLUS clothes hanging bars		BASIC clothes-hanging bars	PLUS clothes-hanging bars			
	Dpt 41,7 Th 2,5 	Dpt 41,7 Th 2,5 	Dpt 41,7 Th 2,5 	Dpt 41,7 Th 2,5 	Dpt 41,7 Th 2,5 	Dpt 41,7 Th 2,5 					
Code	PK22.07T	PK22.06M	PK22.09F	PK22.08Z	PK22.11K	PK22.10C	P08.55Q	PK01.55W			
	*										

## BIG

	Movable shelves		Movable shelves with BASIC clothes hanging bars		Movable shelves with PLUS clothes hanging bars		BASIC clothes-hanging bars	PLUS clothes-hanging bars			
	Dpt 41,7 Th 2,5 	Dpt 41,7 Th 2,5 	Dpt 41,7 Th 2,5 	Dpt 41,7 Th 2,5 	Dpt 41,7 Th 2,5 	Dpt 41,7 Th 2,5 					
Code	PK22.16S	PK22.15L	PK22.18E	PK22.17Y	PK22.20H	PK22.19M	P08.61X	PK01.59X			
	*										

## LARGE

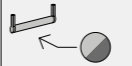
W 140.5/150.5

	Movable shelves		Movable shelves with BASIC clothes hanging bars		Movable shelves with PLUS clothes hanging bars		BASIC clothes-hanging bars		PLUS clothes-hanging bars				
	Dpt 41,7 Th 2,5 	Dpt 41,7 Th 2,5 	Dpt 41,7 Th 2,5 	Dpt 41,7 Th 2,5 	Dpt 41,7 Th 2,5 	Dpt 41,7 Th 2,5 	W 46,7 	W 77,5 	W 46,7 	W 77,5 			
Code	PK22.06M	PK22.30P	PK22.08Z	PK22.32B	PK22.10C	PK22.34Q	P08.55Q	P08.66Z	PK01.55W	PK01.62G			
	*												

### BERNARDO

Clothes hangers

Dpt 2

W 28

(A) 1 for elements HT 193.6; 1 or 2, at the discretion, for elements HT 225.6 - 241.6 - 257.6 - 289.6.

(B) For elements HT 241.6 - 257.6 - 289.6.

\* Tray (optional) positions

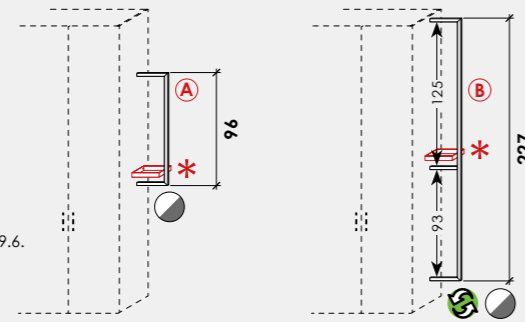

### Tray

Ht 4

Dpt 15

W 25

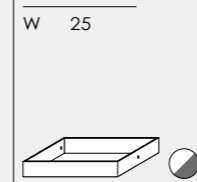

### Metal clothes reacher pole

Ht 115

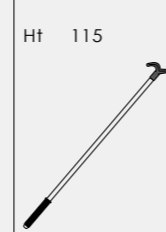

### Lighting with sensor

Complete kits with 1 Power pack.  
Cover color Aluminum and Titanium.

Dpt 19,2

W 11,2

Th 0,6

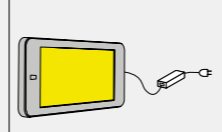

Code		P07.70T	P08.31K	P08.32Q	PL04.17C	P08.71B							
------	--	---------	---------	---------	----------	---------	--	--	--	--	--	--	--

 Components in **GROUP 2 colors**

 AL1A  GZ8T

\* Price of the element in the GROUP 2 colors (CARCASE colors excluded)

GROUP 1 colors	Rovere Dorian <b>RD5T</b>	Rovere white <b>RW3Q</b>	Noce naturale <b>NN7H</b>	Eucalipto <b>CL1X</b>	Domy <b>DM7P</b>	Bianco UV <b>BU3Q</b>
	Ciliegio bianco <b>CB6K</b>	Malta <b>ML7H</b>	Feltro <b>FL8X</b>	Cemento Masdar <b>CM3Q</b>	Blu indaco <b>BI4B</b>	
	Noce <b>NC4B</b>	Desert <b>DS9L</b>	Canapa <b>CN1X</b>	Moka <b>MK6B</b>	Cipria <b>CP4J</b>	
	Bianco opaco <b>BI7A</b>	Grigio Dorian <b>GL4R</b>	Basalto <b>BS5T</b>	Grigio titanio <b>GZ8T</b>	Rosa bubble <b>RB7Y</b>	
	Agave <b>GV7A</b>	Verde Alpi <b>VA5T</b>	Cadaques <b>CQ3Q</b>	Giallo zafferano <b>GZ8A</b>		
	Blu opale <b>BO7H</b>			Corallo <b>CR5T</b>		

Types and colors FRONT	ONE	<table border="1"> <tr> <td>Rovere white <b>RW3Q</b></td> <td>Rovere Dorian <b>RD5T</b></td> <td>Ciliegio bianco <b>CB6K</b></td> <td>Noce naturale <b>NN7H</b></td> <td>Noce <b>NC4B</b></td> <td>Eucalipto <b>CL1X</b></td> <td>Malta <b>ML7H</b></td> </tr> <tr> <td>Feltro <b>FL8X</b></td> <td>Cemento Masdar <b>CM3Q</b></td> <td>Bianco opaco <b>BI7A</b></td> <td>Desert <b>DS9L</b></td> <td>Canapa <b>CN1X</b></td> <td>Moka <b>MK6B</b></td> <td>Grigio Dorian <b>GL4R</b></td> </tr> <tr> <td>Basalto <b>BS5T</b></td> <td>Grigio titanio <b>GZ8T</b></td> <td>Domy <b>DM7P</b></td> <td>Agave <b>GV7A</b></td> <td>Verde Alpi <b>VA5T</b></td> <td>Cadaques <b>CQ3Q</b></td> <td>Blu indaco <b>BI4B</b></td> </tr> <tr> <td>Blu opale <b>BO7H</b></td> <td>Cipria <b>CP4J</b></td> <td>Rosa bubble <b>RB7Y</b></td> <td>Giallo zafferano <b>GZ8A</b></td> <td>Corallo <b>CR5T</b></td> <td></td> <td></td> </tr> </table>							Rovere white <b>RW3Q</b>	Rovere Dorian <b>RD5T</b>	Ciliegio bianco <b>CB6K</b>	Noce naturale <b>NN7H</b>	Noce <b>NC4B</b>	Eucalipto <b>CL1X</b>	Malta <b>ML7H</b>	Feltro <b>FL8X</b>	Cemento Masdar <b>CM3Q</b>	Bianco opaco <b>BI7A</b>	Desert <b>DS9L</b>	Canapa <b>CN1X</b>	Moka <b>MK6B</b>	Grigio Dorian <b>GL4R</b>	Basalto <b>BS5T</b>	Grigio titanio <b>GZ8T</b>	Domy <b>DM7P</b>	Agave <b>GV7A</b>	Verde Alpi <b>VA5T</b>	Cadaques <b>CQ3Q</b>	Blu indaco <b>BI4B</b>	Blu opale <b>BO7H</b>	Cipria <b>CP4J</b>	Rosa bubble <b>RB7Y</b>	Giallo zafferano <b>GZ8A</b>	Corallo <b>CR5T</b>		
		Rovere white <b>RW3Q</b>	Rovere Dorian <b>RD5T</b>	Ciliegio bianco <b>CB6K</b>	Noce naturale <b>NN7H</b>	Noce <b>NC4B</b>	Eucalipto <b>CL1X</b>	Malta <b>ML7H</b>																												
Feltro <b>FL8X</b>	Cemento Masdar <b>CM3Q</b>	Bianco opaco <b>BI7A</b>	Desert <b>DS9L</b>	Canapa <b>CN1X</b>	Moka <b>MK6B</b>	Grigio Dorian <b>GL4R</b>																														
Basalto <b>BS5T</b>	Grigio titanio <b>GZ8T</b>	Domy <b>DM7P</b>	Agave <b>GV7A</b>	Verde Alpi <b>VA5T</b>	Cadaques <b>CQ3Q</b>	Blu indaco <b>BI4B</b>																														
Blu opale <b>BO7H</b>	Cipria <b>CP4J</b>	Rosa bubble <b>RB7Y</b>	Giallo zafferano <b>GZ8A</b>	Corallo <b>CR5T</b>																																
matte																																				
glossy																																				
		<table border="1"> <tr> <td>Bianco UV <b>BU3Q</b></td> <td></td> <td></td> <td></td> <td></td> <td></td> <td></td> </tr> </table>							Bianco UV <b>BU3Q</b>																											
Bianco UV <b>BU3Q</b>																																				
	CLUB	<table border="1"> <tr> <td>Rovere white <b>RW3Q</b></td> <td>Rovere Dorian <b>RD5T</b></td> <td>Ciliegio bianco <b>CB6K</b></td> <td>Noce naturale <b>NN7H</b></td> <td>Noce <b>NC4B</b></td> <td>Eucalipto <b>CL1X</b></td> <td>Malta <b>ML7H</b></td> </tr> <tr> <td>Feltro <b>FL8X</b></td> <td>Cemento Masdar <b>CM3Q</b></td> <td>Bianco opaco <b>BI7A</b></td> <td>Desert <b>DS9L</b></td> <td>Canapa <b>CN1X</b></td> <td>Moka <b>MK6B</b></td> <td>Grigio Dorian <b>GL4R</b></td> </tr> <tr> <td>Basalto <b>BS5T</b></td> <td>Grigio titanio <b>GZ8T</b></td> <td>Domy <b>DM7P</b></td> <td>Agave <b>GV7A</b></td> <td>Verde Alpi <b>VA5T</b></td> <td>Cadaques <b>CQ3Q</b></td> <td>Blu indaco <b>BI4B</b></td> </tr> <tr> <td>Blu opale <b>BO7H</b></td> <td>Cipria <b>CP4J</b></td> <td>Rosa bubble <b>RB7Y</b></td> <td>Giallo zafferano <b>GZ8A</b></td> <td>Corallo <b>CR5T</b></td> <td></td> <td></td> </tr> </table>							Rovere white <b>RW3Q</b>	Rovere Dorian <b>RD5T</b>	Ciliegio bianco <b>CB6K</b>	Noce naturale <b>NN7H</b>	Noce <b>NC4B</b>	Eucalipto <b>CL1X</b>	Malta <b>ML7H</b>	Feltro <b>FL8X</b>	Cemento Masdar <b>CM3Q</b>	Bianco opaco <b>BI7A</b>	Desert <b>DS9L</b>	Canapa <b>CN1X</b>	Moka <b>MK6B</b>	Grigio Dorian <b>GL4R</b>	Basalto <b>BS5T</b>	Grigio titanio <b>GZ8T</b>	Domy <b>DM7P</b>	Agave <b>GV7A</b>	Verde Alpi <b>VA5T</b>	Cadaques <b>CQ3Q</b>	Blu indaco <b>BI4B</b>	Blu opale <b>BO7H</b>	Cipria <b>CP4J</b>	Rosa bubble <b>RB7Y</b>	Giallo zafferano <b>GZ8A</b>	Corallo <b>CR5T</b>		
Rovere white <b>RW3Q</b>		Rovere Dorian <b>RD5T</b>	Ciliegio bianco <b>CB6K</b>	Noce naturale <b>NN7H</b>	Noce <b>NC4B</b>	Eucalipto <b>CL1X</b>	Malta <b>ML7H</b>																													
Feltro <b>FL8X</b>	Cemento Masdar <b>CM3Q</b>	Bianco opaco <b>BI7A</b>	Desert <b>DS9L</b>	Canapa <b>CN1X</b>	Moka <b>MK6B</b>	Grigio Dorian <b>GL4R</b>																														
Basalto <b>BS5T</b>	Grigio titanio <b>GZ8T</b>	Domy <b>DM7P</b>	Agave <b>GV7A</b>	Verde Alpi <b>VA5T</b>	Cadaques <b>CQ3Q</b>	Blu indaco <b>BI4B</b>																														
Blu opale <b>BO7H</b>	Cipria <b>CP4J</b>	Rosa bubble <b>RB7Y</b>	Giallo zafferano <b>GZ8A</b>	Corallo <b>CR5T</b>																																
		<p>Specify the color of the CLUB handle</p> <table border="1"> <tr> <td>Bianco opaco <b>BI7A</b></td> <td>Desert <b>DS9L</b></td> <td>Canapa <b>CN1X</b></td> <td>Moka <b>MK6B</b></td> <td>Grigio Dorian <b>GL4R</b></td> <td>Basalto <b>BS5T</b></td> <td>Grigio titanio <b>GZ8T</b></td> </tr> <tr> <td>Domy <b>DM7P</b></td> <td>Agave <b>GV7A</b></td> <td>Verde Alpi <b>VA5T</b></td> <td>Cadaques <b>CQ3Q</b></td> <td>Blu indaco <b>BI4B</b></td> <td>Blu opale <b>BO7H</b></td> <td>Cipria <b>CP4J</b></td> </tr> <tr> <td>Rosa bubble <b>RB7Y</b></td> <td>Giallo zafferano <b>GZ8A</b></td> <td>Corallo <b>CR5T</b></td> <td></td> <td></td> <td></td> <td></td> </tr> </table>							Bianco opaco <b>BI7A</b>	Desert <b>DS9L</b>	Canapa <b>CN1X</b>	Moka <b>MK6B</b>	Grigio Dorian <b>GL4R</b>	Basalto <b>BS5T</b>	Grigio titanio <b>GZ8T</b>	Domy <b>DM7P</b>	Agave <b>GV7A</b>	Verde Alpi <b>VA5T</b>	Cadaques <b>CQ3Q</b>	Blu indaco <b>BI4B</b>	Blu opale <b>BO7H</b>	Cipria <b>CP4J</b>	Rosa bubble <b>RB7Y</b>	Giallo zafferano <b>GZ8A</b>	Corallo <b>CR5T</b>											
Bianco opaco <b>BI7A</b>	Desert <b>DS9L</b>	Canapa <b>CN1X</b>	Moka <b>MK6B</b>	Grigio Dorian <b>GL4R</b>	Basalto <b>BS5T</b>	Grigio titanio <b>GZ8T</b>																														
Domy <b>DM7P</b>	Agave <b>GV7A</b>	Verde Alpi <b>VA5T</b>	Cadaques <b>CQ3Q</b>	Blu indaco <b>BI4B</b>	Blu opale <b>BO7H</b>	Cipria <b>CP4J</b>																														
Rosa bubble <b>RB7Y</b>	Giallo zafferano <b>GZ8A</b>	Corallo <b>CR5T</b>																																		
	WINDOW	<table border="1"> <tr> <td>Trasparente <b>TR9M</b></td> <td>Trasparente fumé <b>FT8P</b></td> <td>Stop-sol <b>ST6P</b></td> <td>Specchio <b>SP7L</b></td> </tr> </table>				Trasparente <b>TR9M</b>	Trasparente fumé <b>FT8P</b>	Stop-sol <b>ST6P</b>	Specchio <b>SP7L</b>																											
Trasparente <b>TR9M</b>		Trasparente fumé <b>FT8P</b>	Stop-sol <b>ST6P</b>	Specchio <b>SP7L</b>																																
		<p>Specify the color of the aluminum frame</p> <table border="1"> <tr> <td>Alluminio <b>AL1A</b></td> <td>Titan grey <b>TG7H</b></td> </tr> </table>				Alluminio <b>AL1A</b>	Titan grey <b>TG7H</b>																													
Alluminio <b>AL1A</b>	Titan grey <b>TG7H</b>																																			

**FLEXO walk-in closet**

FLEXO walk-in closet - technical information	240
FLEXO walk-in closet Ht 193.6	242
FLEXO walk-in closet Ht 193.6 - corner units	244
FLEXO walk-in closet Ht 225.6	246
FLEXO walk-in closet Ht 225.6 - corner units	248
FLEXO walk-in closet Ht 241.6	250
FLEXO walk-in closet Ht 241.6 - corner units	252
FLEXO walk-in closet Ht 257.6	254
FLEXO walk-in closet Ht 257.6 - corner units	256
FLEXO walk-in closet Ht 103 ÷ 302	258
FLEXO walk-in closet Ht 103 ÷ 302 - corner units	260
Accessories for FLEXO walk-in closet	262



# FLEXO walk-in closet - technical information

## FLEXO Ht 193.6 - 225.6 - 241.6 - 257.6

- Structure equipped and with elements in succession.
- The side panels are fixed to the wall using the supplied hardware.
- Side panels are pre-drilled for shelves with a pitch of 32 cm except the last compartment at the top which has a 28 cm wheelbase.
- The bottom panel can be added or not, depending on the use of the unit.
- The shelves and the bottom (if there is one), are fixed to the side panels with shelf blocking support systems.
- The shelves can be equipped with PLUS clothes-hanging bars and led lighting.
- Back panels (if present) always cover the full height of the unit and are included and fixed between the side panels.
- In the event of recess mounting, an extra 1.5 cm space in width is required in presence of a back panel and 0.5 cm in absence of a back panel (in order to balance any size differences).
- You cannot alternate modules with a back panel and modules without in the same composition.
- It can also be combined with modular wardrobes and walk-in wardrobes.

## FLEXO Ht 103 ÷ 302 - Side panels are fixed between floor and ceiling

- The structure can be equipped for ceiling support and is adjustable in height for rooms/recesses with dimensions Ht 302 cm max to 103 cm min.
- The height of the side panels and back panel, if there is one, must be adjusted in relation to the distance between floor and ceiling; this distance must be indicated when ordering.
- The side panels are fixed between floor and ceiling, with adjustable middle-support feet (top and bottom) which allow a maximum adjustment of 10 mm for each side (20 total). We recommend that you check the room height in more than one point in order to find excessive differences. With false ceilings you should check that in the event of inflection, the height difference does not exceed the 2 cm maximum adjustable range of the middle-support feet.
- Side panels are pre-drilled with a pitch of 32 cm (from the bottom) for shelves; there is also a pre-drilled hole at 37 mm from the top edge of the side panel for the insertion of a finishing top shelf which will be lowered 24 mm in respect to the side panel after mounting (in order to allow its positioning).
- The bottom panel can be added or not, depending on the use of the unit.
- The shelves and the bottom (if there is one), are fixed to the side panels with shelf blocking support systems.
- The shelves can be equipped with PLUS clothes-hanging bars and led lighting.
- Back panels (if present) always cover the full height of the unit and are included and fixed between the side panels.
- In the event of recess mounting, an extra 1.5 cm space in width is required in presence of a back panel and 0.5 cm in absence of a back panel (in order to balance any size differences).
- You cannot alternate modules with a back panel and modules without in the same composition.

### When ordering you must:

- Draw and/or send a drawing of the whole composition. We recommend using our graphic software.
- Make sure that every composition is provided with an end side panel.
- For FLEXO Ht 103 ÷ 302, indicate the height of the room (floor-ceiling).

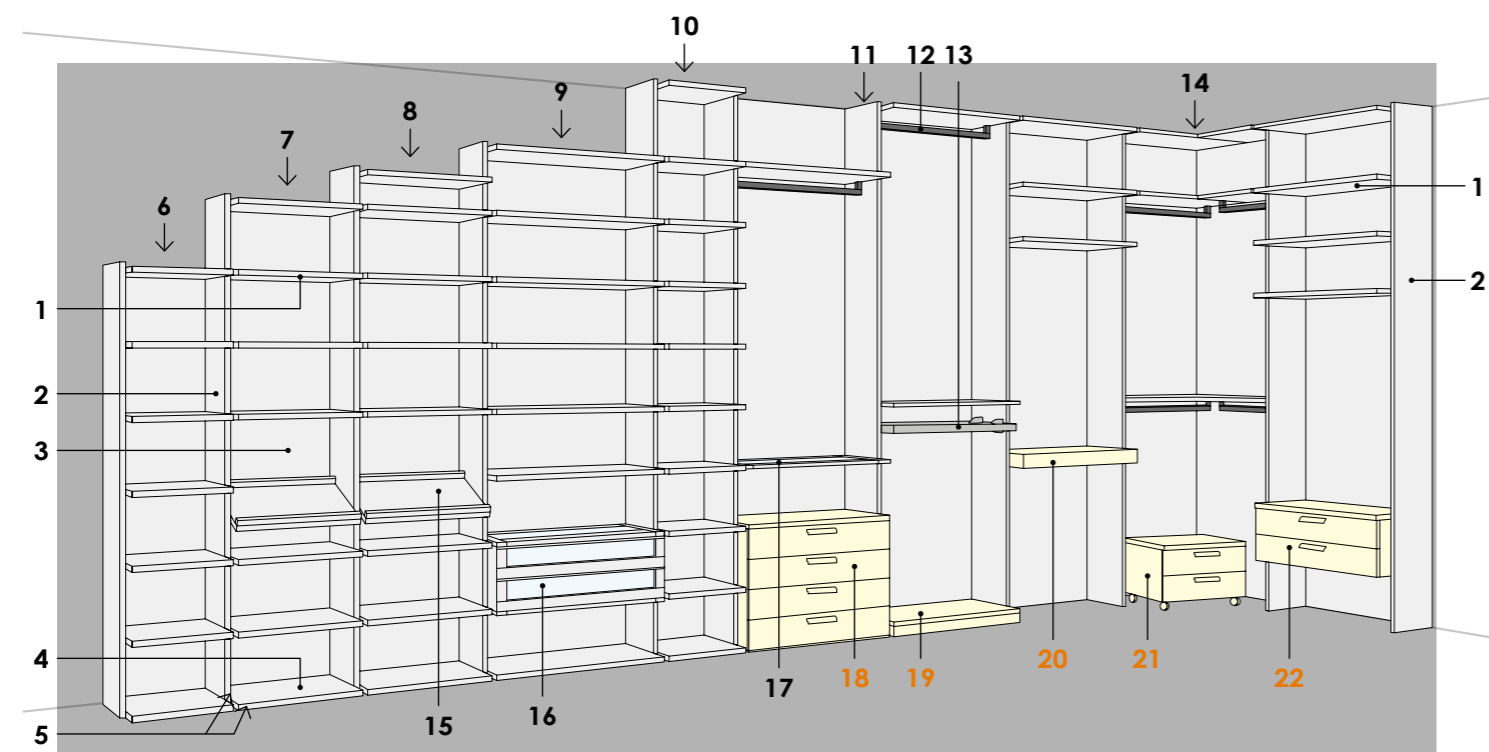

- |   |  |   |
|---|--|---|
| 1 Shelf Th 2.5 Dpt 45.8                       | 10 Element Ht 103 ÷ 302                  | <b>Optional elements (see page references):</b>                             |
| 2 Side panel Th 2.5 Dpt 33.3                  | 11 Adjustable middle-support feet (top)  |   |
| 3 Full height back panel Th 1.8               | 12 PLUS clothes rail                     |   |
| 4 Bottom Th 2.5 Dpt 45.8 with adjustable feet | 13 Pull-out pant rack                    |   |
| 5 Adjustable middle-support feet (bottom)     | 14 Corner element (type B)               |   |
| 6 Element Ht 193.6                            | 15 Shoe rack                             |   |
| 7 Element Ht 225.6                            | 16 Drawer unit Dpt 45.8                  |   |
| 8 Element Ht 241.6                            | 17 Frame and glass shelf Th 1.8 Dpt 45.8 |   |
| 9 Element Ht 257.6                            |  |   |
|   |  |   |
|   |  | 19 Bench / PODIO  |
|   |  | 20 Desk / PODIO   |
|   |  | 21 Dressers / Bed side tables   |
|   |  | 22 Suspended modular unit (can be fixed to side panels, wall or back panel) |

## PLUS clothes-hanging bars in aluminum

It is fixed to the shelf/top panel.  
Available in Alluminio (AL1A) and Grigio titanio (GZ8T) colors.  
Tube Ø 2.8.

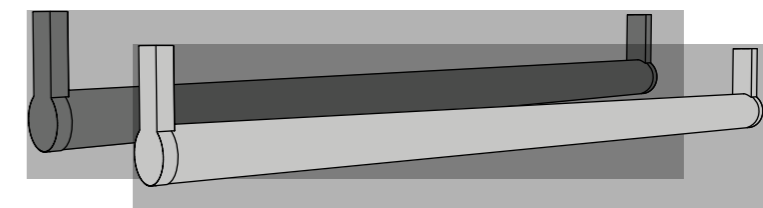

## Wooden shelf with led strip light

The light is a led strip (60 led/m) assembled on the back side of the shelf.  
The strip shares the same length with the shelf and it enlightens the compartments above and below.  
The colour tone of the led strip is natural.  
We provide a power pack (with a surcharge) able to support from 1 to 6 shelves W 45/60 or from 1 to 4 shelves W 90.

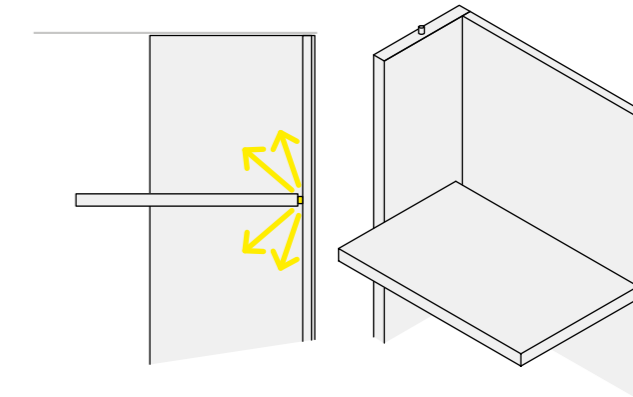

## Led spot light

The lighting type is natural.  
We provide a power pack (with a surcharge) able to support from 1 to 6 spotlights.  
Spot lights are assembled as showed below (wiring in sight).

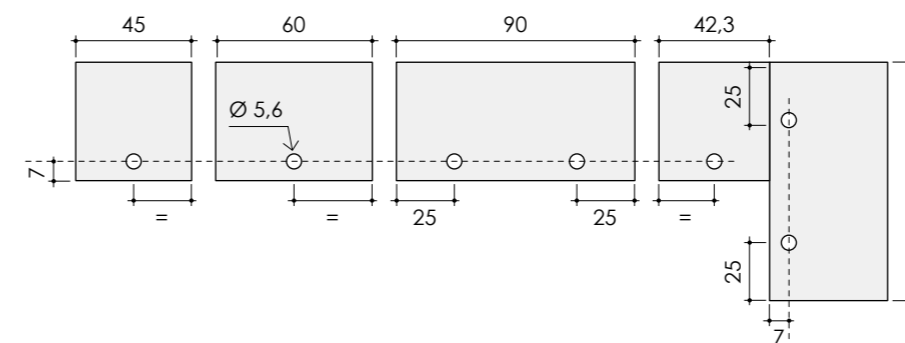
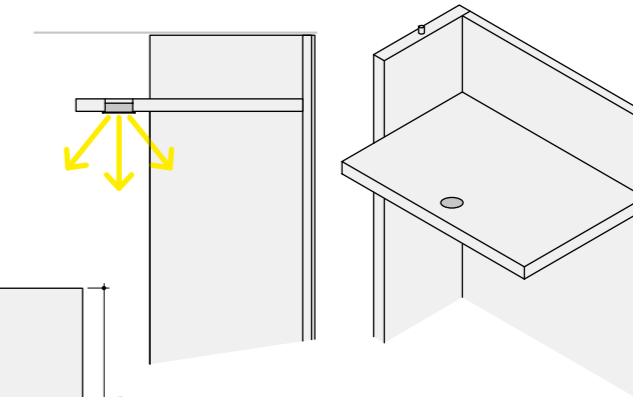

## On/off switch

The on/off switching of the led spot light or led strip light can be done in 2 different ways:

- 1) By connecting the power pack to your home electrical system and using your own standard power switch.
- 2) By ordering our wireless on/off switch from catalogue. This switch allows you to turn on or off all the led lights (Max 30 strip led or spot lights).

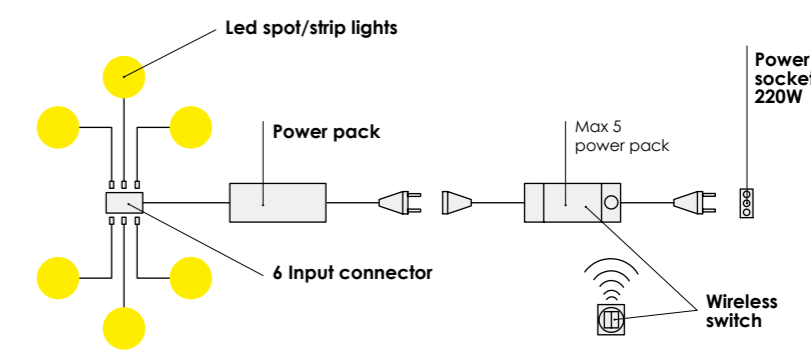
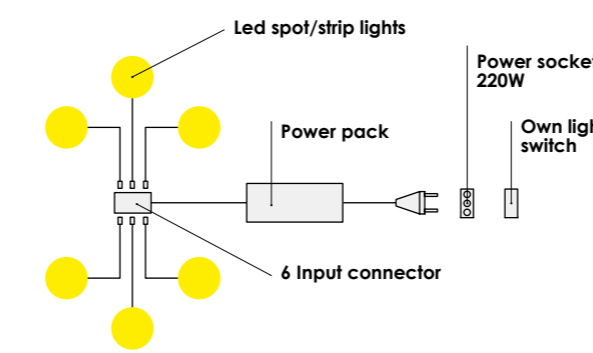

# FLEXO walk-in closet Ht 193.6

Price and equipment shown below refer to simple shelves.  
You cannot alternate modules with back panels and modules without.

With back panel  
Dpt 48

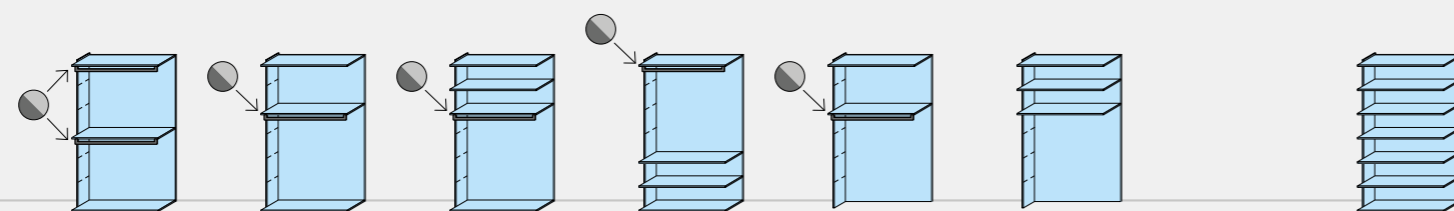

<b>W 47.5</b>	Code	PK26.00Q	PK26.01W	PK26.02C	PK26.03K	PK26.04R	PK26.05X	PK26.06D						
<b>W 62.5</b>	Code	PK26.07L	PK26.08S	PK26.09Y	PK26.10V	PK26.11B	PK26.12H	PK26.13Q						
<b>W 92.5</b>	Code	PK26.14W	PK26.15C	PK26.16K	PK26.17R	PK26.18X	PK26.19D	PK26.20A						
Custom-made Max 92.4 Min 32.5	Code	-	-	-	-	-	PK26.21G	PK26.22P						

Without back panel  
Dpt 46

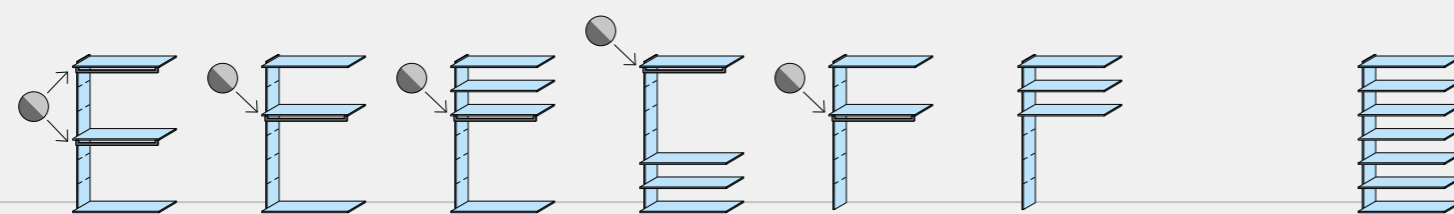

<b>W 47.5</b>	Code	PK26.23V	PK26.24B	PK26.25H	PK26.26Q	PK26.27W	PK26.28C	PK26.29K						
<b>W 62.5</b>	Code	PK26.30F	PK26.31N	PK26.32U	PK26.33A	PK26.34G	PK26.35P	PK26.36V						
<b>W 92.5</b>	Code	PK26.37B	PK26.38H	PK26.39Q	PK26.40M	PK26.41T	PK26.42Z	PK26.43F						
Custom-made Max 92.4 Min 32.5	Code	-	-	-	-	-	PK26.44N	PK26.45U						

Movable shelves  
Th 2.5 Dpt 45.8

	Simple	With clothes rail	With led	With led and clothes rail	Frame and glass Th 1.8 Maximum recommended load 5 kg	
<b>W 45</b>	Code	PL21.30M	PL21.77D	PL21.33F	PL21.80P	-
<b>W 60</b>	Code	PL21.36A	PL21.78L	PL21.39V	PL21.81V	-
<b>W 90</b>	Code	PL21.42E	PL21.79S	PL21.45Z	PL21.82B	PL21.69M
Custom-made Max 89.9 Min 30	Code	PL21.48U	-	-	-	-

Bottom  
Th 2.5 Dpt 45.8  
with adjustable feet

<b>W 45</b>	Code	PL21.65L
<b>W 60</b>	Code	PL21.66S
<b>W 90</b>	Code	PL21.67Y
Custom-made Max 89.9 Min 30	Code	PL21.68E

Side panel  
Th 2.5 Dpt 33.3 Ht 193.6

<b>Code</b>	PK26.99X
-------------	----------

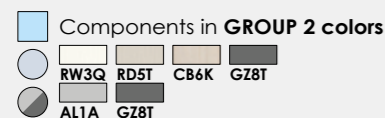

# FLEXO walk-in closet Ht 193.6 - corner units

Price and equipment shown below refer to simple shelves.  
You cannot alternate modules with back panels and modules without.

With back panel  
Dpt 48

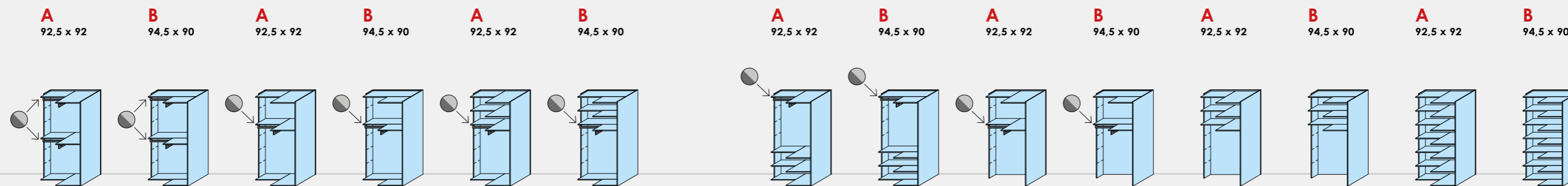

Code	PK49.00K	PK49.01R	PK49.02X	PK49.03D	PK49.04L	PK49.05S	PK49.06Y	PK49.07E	PK49.08M	PK49.09T	PK49.10Q	PK49.11W	PK49.12C	PK49.13K
------	----------	----------	----------	----------	----------	----------	----------	----------	----------	----------	----------	----------	----------	----------

Without back panel  
Dpt 46

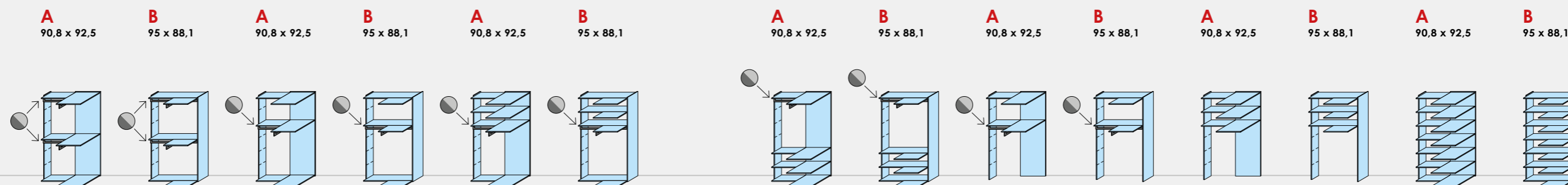

Code	PK49.14R	PK49.15X	PK49.16D	PK49.17L	PK49.18S	PK49.19Y	PK49.20V	PK49.21B	PK49.22H	PK49.23Q	PK49.24W	PK49.25C	PK49.26K	PK49.27R
------	----------	----------	----------	----------	----------	----------	----------	----------	----------	----------	----------	----------	----------	----------

Movable shelves for corner Th 2.5  
(88,1 x 90)

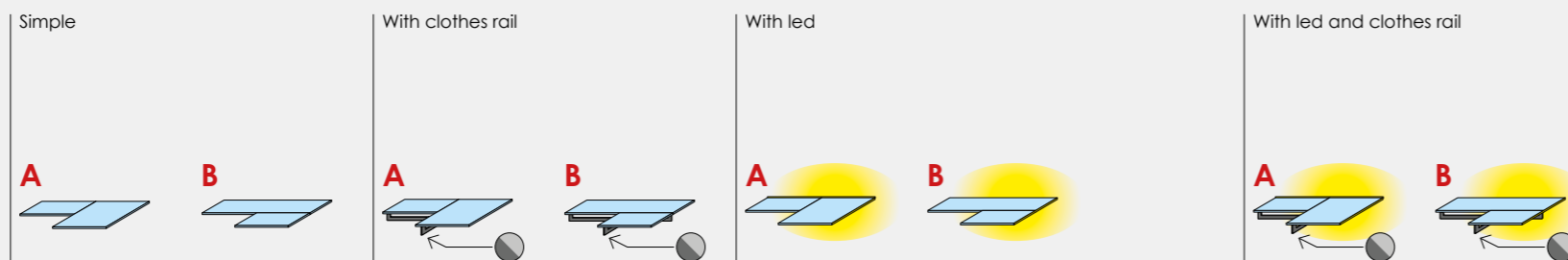

Code	PK26.80H	PK26.81Q	PK26.82W	PK26.83C	PK26.84K	PK26.85R	PK26.86X	PK26.87D						
------	----------	----------	----------	----------	----------	----------	----------	----------	--	--	--	--	--	--

Bottom Th 2.5 Dpt 45.8  
with adjustable feet

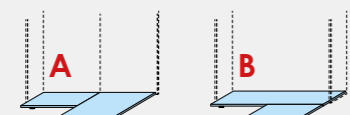

Code	PK26.88L	PK26.89S
------	----------	----------

Side panel Th 2.5 Dpt 33.3 Ht 193.6



Code	PK26.99X
------	----------

Full corner overall size A

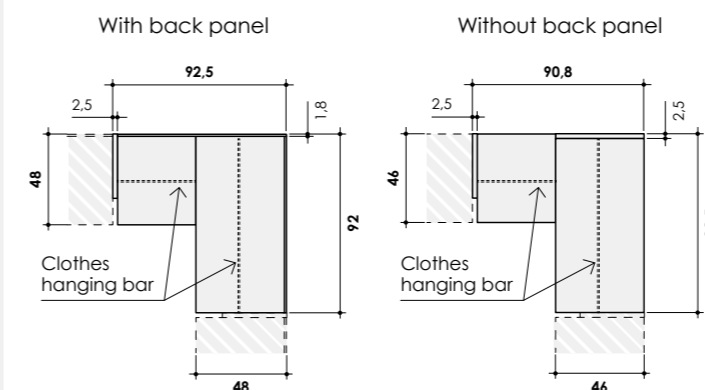

Full corner overall size B

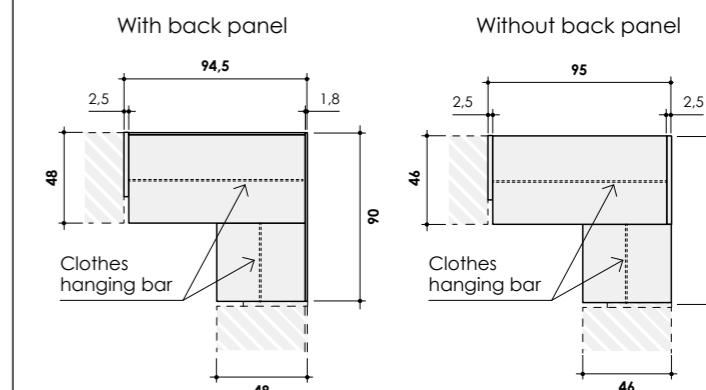

Components in GROUP 2 colors  
AL1A GZ8T

FLEXO walk-in closet

# FLEXO walk-in closet Ht 225.6

Price and equipment shown below refer to simple shelves.  
You cannot alternate modules with back panels and modules without.

With back panel  
Dpt 48

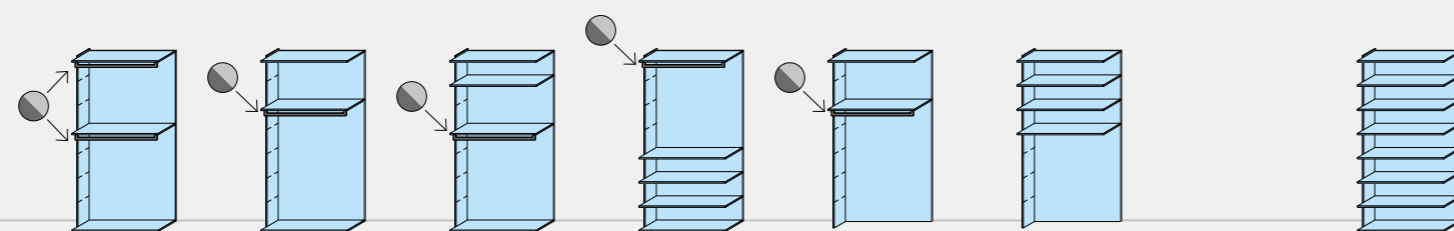

<b>W 47.5</b>	Code	PK27.00U	PK27.01A	PK27.02G	PK27.03P	PK27.04V	PK27.05B	PK27.06H						
<b>W 62.5</b>	Code	PK27.07Q	PK27.08W	PK27.09C	PK27.10Z	PK27.11F	PK27.12N	PK27.13U						
<b>W 92.5</b>	Code	PK27.14A	PK27.15G	PK27.16P	PK27.17V	PK27.18B	PK27.19H	PK27.20E						
Custom-made Max 92.4 Min 32.5	Code	-	-	-	-	-	PK27.21M	PK27.22T						

Without back panel  
Dpt 46

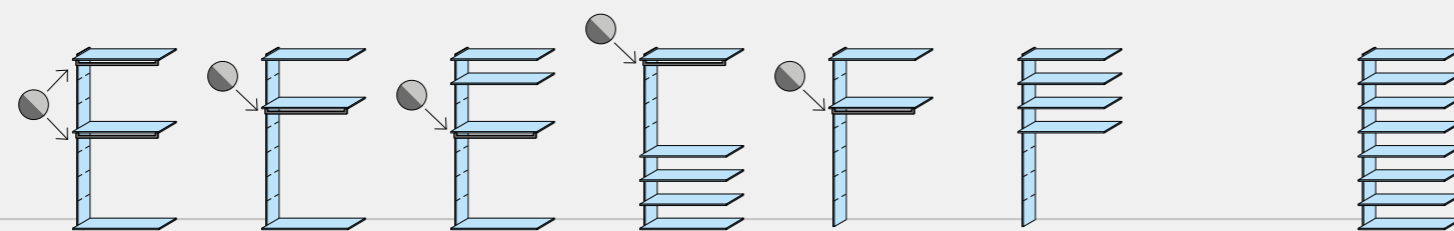

<b>W 47.5</b>	Code	PK27.23Z	PK27.24F	PK27.25N	PK27.26U	PK27.27A	PK27.28G	PK27.29P						
<b>W 62.5</b>	Code	PK27.30L	PK27.31S	PK27.32Y	PK27.33E	PK27.34M	PK27.35T	PK27.36Z						
<b>W 92.5</b>	Code	PK27.37F	PK27.38N	PK27.39U	PK27.40R	PK27.41X	PK27.42D	PK27.43L						
Custom-made Max 92.4 Min 32.5	Code	-	-	-	-	-	PK27.44S	PK27.45Y						

Movable shelves  
Th 2.5 Dpt 45.8

	Simple	With clothes rail	With led	With led and clothes rail	Frame and glass Th 1.8 Maximum recommended load 5 kg	
<b>W 45</b>	Code	PL21.30M	PL21.77D	PL21.33F	PL21.80P	-
<b>W 60</b>	Code	PL21.36A	PL21.78L	PL21.39V	PL21.81V	-
<b>W 90</b>	Code	PL21.42E	PL21.79S	PL21.45Z	PL21.82B	PL21.69M
Custom-made Max 89.9 Min 30	Code	PL21.48U	-	-	-	-

Bottom  
Th 2.5 Dpt 45.8  
with adjustable feet

<b>W 45</b>	Code	PL21.65L
<b>W 60</b>	Code	PL21.66S
<b>W 90</b>	Code	PL21.67Y
Custom-made Max 89.9 Min 30	Code	PL21.68E

Side panel  
Th 2.5 Dpt 33.3 Ht 225.6

<b>W 45</b>	Code	PK27.99B
<b>W 60</b>	Code	PK27.99B
<b>W 90</b>	Code	PK27.99B
Custom-made Max 89.9 Min 30	Code	PK27.99B

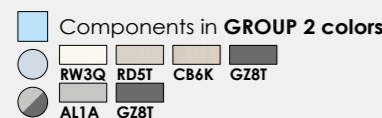

# FLEXO walk-in closet Ht 225.6 - corner units

Price and equipment shown below refer to simple shelves.  
You cannot alternate modules with back panels and modules without.

With back panel  
Dpt 48

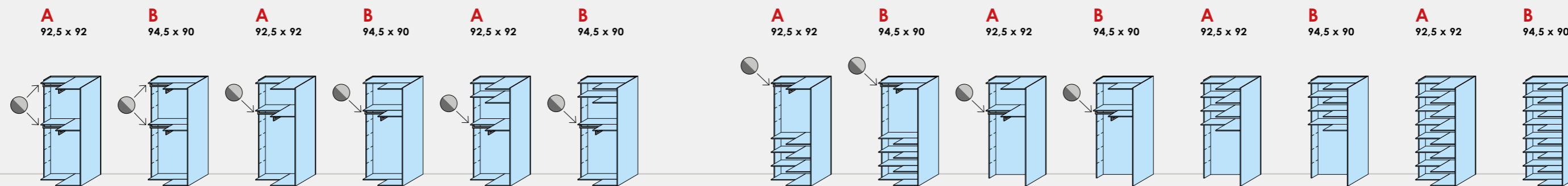

Code	PK49.28X	PK49.29D	PK49.30A	PK49.31G	PK49.32P	PK49.33V	PK49.34B	PK49.35H	PK49.36Q	PK49.37W	PK49.38C	PK49.39K	PK49.40F	PK49.41N
------	----------	----------	----------	----------	----------	----------	----------	----------	----------	----------	----------	----------	----------	----------

Without back panel  
Dpt 46

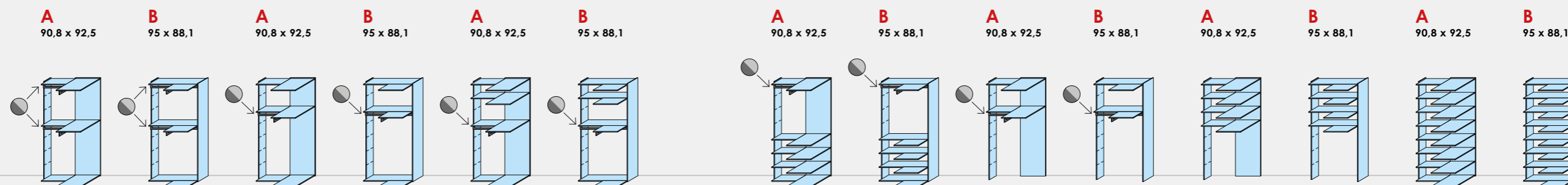

Code	PK49.42U	PK49.43A	PK49.44G	PK49.45P	PK49.46V	PK49.47B	PK49.48H	PK49.49Q	PK49.50M	PK49.51T	PK49.52Z	PK49.53F	PK49.54N	PK49.55U
------	----------	----------	----------	----------	----------	----------	----------	----------	----------	----------	----------	----------	----------	----------

Movable shelves for corner Th 2.5 (88,1 x 90)

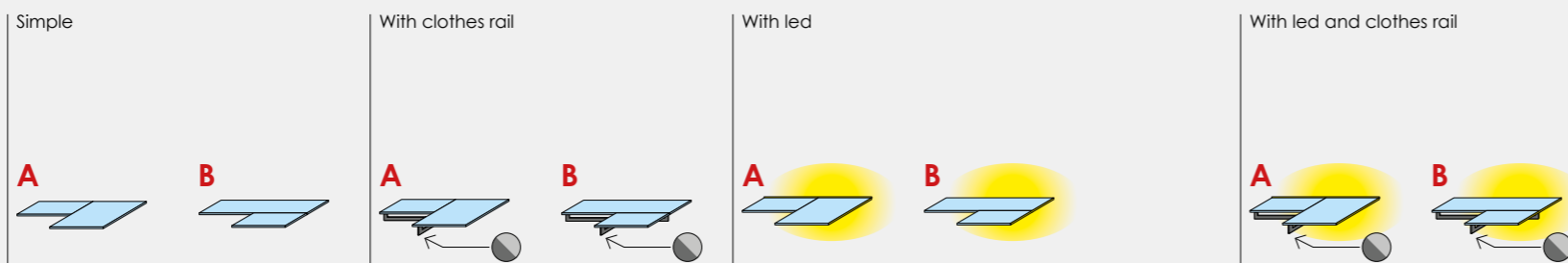

Code	PK26.80H	PK26.81Q	PK26.82W	PK26.83C	PK26.84K	PK26.85R	PK26.86X	PK26.87D						
------	----------	----------	----------	----------	----------	----------	----------	----------	--	--	--	--	--	--

Bottom Th 2.5 Dpt 45.8 with adjustable feet

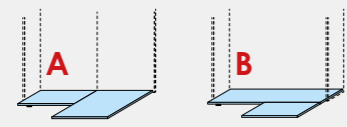

Code	PK26.88L	PK26.89S
------	----------	----------

Side panel Th 2.5 Dpt 33.3 Ht 225.6



Code	PK27.99B
------	----------

Full corner overall size A

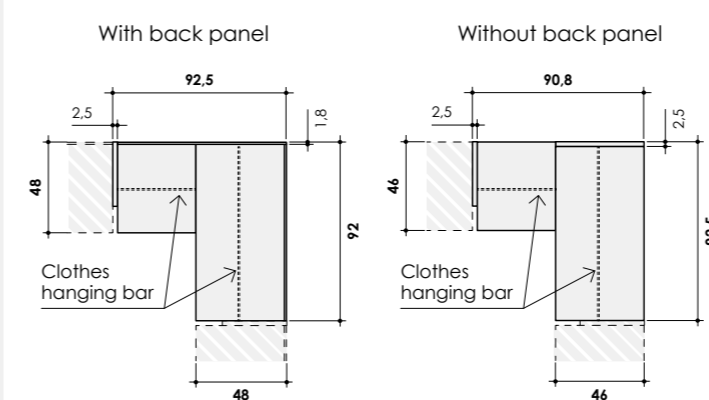

Full corner overall size B

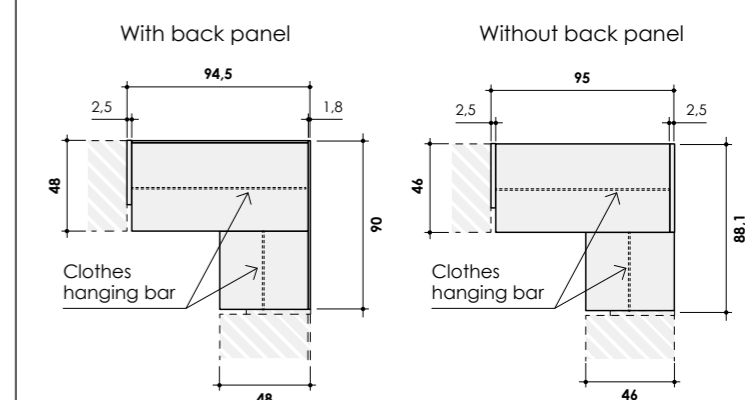

Components in GROUP 2 colors  
AL1A GZ8T

FLEXO walk-in closet

# FLEXO walk-in closet Ht 241.6

Price and equipment shown below refer to simple shelves.  
You cannot alternate modules with back panels and modules without.

With back panel  
Dpt 48

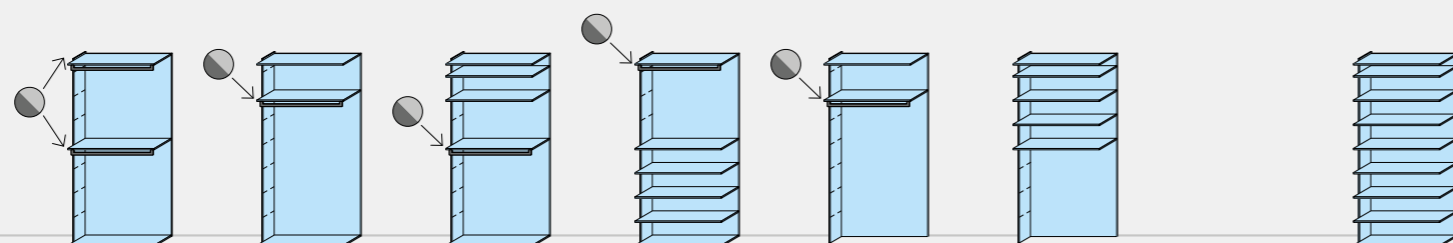

<b>W 47.5</b>	Code	PK29.00C	PK29.01K	PK29.02R	PK29.03X	PK29.04D	PK29.05L	PK29.06S						
<b>W 62.5</b>	Code	PK29.07Y	PK29.08E	PK29.09M	PK29.10H	PK29.11Q	PK29.12W	PK29.13C						
<b>W 92.5</b>	Code	PK29.14K	PK29.15R	PK29.16X	PK29.17D	PK29.18L	PK29.19S	PK29.20P						
Custom-made Max 92.4 Min 32.5	Code	-	-	-	-	-	PK29.21V	PK29.22B						

Without back panel  
Dpt 46

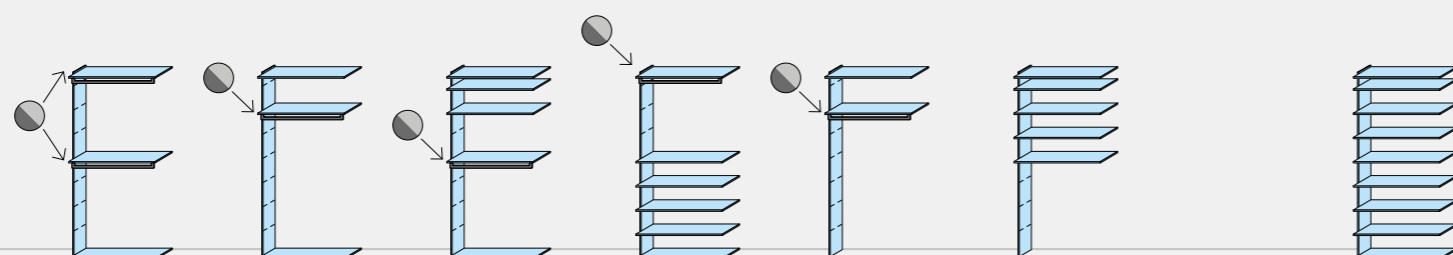

<b>W 47.5</b>	Code	PK29.23H	PK29.24Q	PK29.25W	PK29.26C	PK29.27K	PK29.28R	PK29.29X						
<b>W 62.5</b>	Code	PK29.30U	PK29.31A	PK29.32G	PK29.33P	PK29.34V	PK29.35B	PK29.36H						
<b>W 92.5</b>	Code	PK29.37Q	PK29.38W	PK29.39C	PK29.40Z	PK29.41F	PK29.42N	PK29.43U						
Custom-made Max 92.4 Min 32.5	Code	-	-	-	-	-	PK29.44A	PK29.45G						

Movable shelves  
Th 2.5 Dpt 45.8

	Simple	With clothes rail	With led	With led and clothes rail	Frame and glass Th 1.8 Maximum recommended load 5 kg	
<b>W 45</b>	Code	PL21.30M	PL21.77D	PL21.33F	PL21.80P	-
<b>W 60</b>	Code	PL21.36A	PL21.78L	PL21.39V	PL21.81V	
<b>W 90</b>	Code	PL21.42E	PL21.79S	PL21.45Z	PL21.82B	PL21.69M
Custom-made Max 89.9 Min 30	Code	PL21.48U	-	-	-	-

Bottom  
Th 2.5 Dpt 45.8  
with adjustable feet

<b>W 45</b>	Code	PL21.65L
<b>W 60</b>	Code	PL21.66S
<b>W 90</b>	Code	PL21.67Y
Custom-made Max 89.9 Min 30	Code	PL21.68E

Side panel  
Th 2.5 Dpt 33.3 Ht 241.6

Code	PK29.99L	

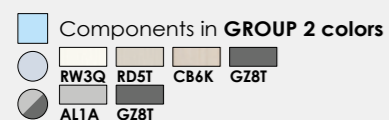

FLEXO walk-in closet



# FLEXO walk-in closet Ht 241.6 - corner units

Price and equipment shown below refer to simple shelves.  
You cannot alternate modules with back panels and modules without.

With back panel  
Dpt 48

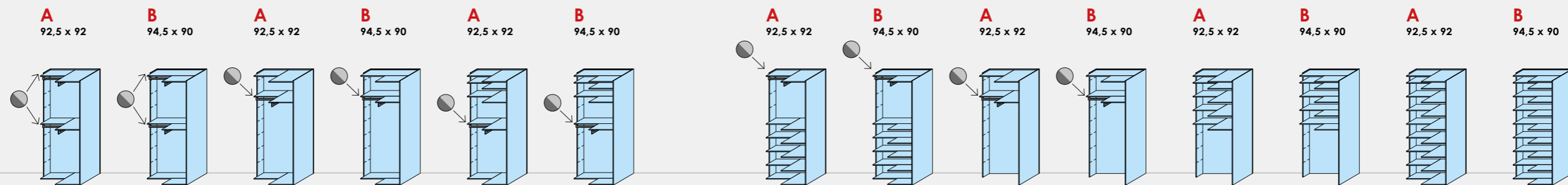

Code	PK29.50E	PK29.51M	PK29.52T	PK29.53Z	PK29.54F	PK29.55N	PK29.56U	PK29.57A	PK29.58G	PK29.59P	PK29.60L	PK29.61S	PK29.62Y	PK29.63E
------	----------	----------	----------	----------	----------	----------	----------	----------	----------	----------	----------	----------	----------	----------

Without back panel  
Dpt 46

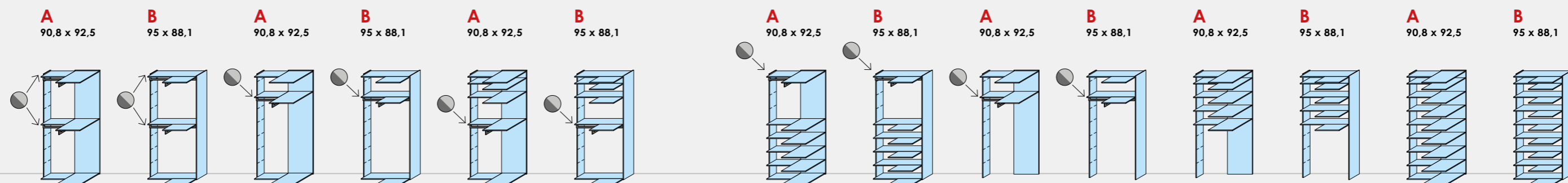

Code	PK29.64M	PK29.65T	PK29.66Z	PK29.67F	PK29.68N	PK29.69U	PK29.70R	PK29.71X	PK29.72D	PK29.73L	PK29.74S	PK29.75Y	PK29.76E	PK29.77M
------	----------	----------	----------	----------	----------	----------	----------	----------	----------	----------	----------	----------	----------	----------

Movable shelves for corner Th 2.5  
(88,1 x 90)

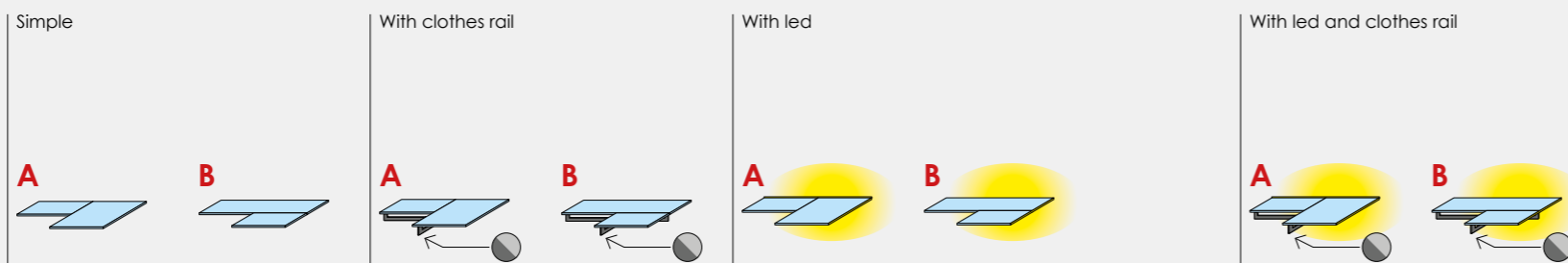

Code	PK26.80H	PK26.81Q	PK26.82W	PK26.83C	PK26.84K	PK26.85R	PK26.86X	PK26.87D						
------	----------	----------	----------	----------	----------	----------	----------	----------	--	--	--	--	--	--

Bottom Th 2.5 Dpt 45.8  
with adjustable feet

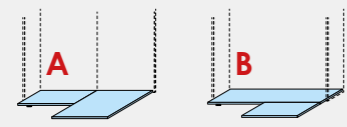

Code	PK26.88L	PK26.89S
------	----------	----------

Side panel Th 2.5 Dpt 33.3 Ht 241.6



Code	PK29.99L
------	----------

Full corner overall size A

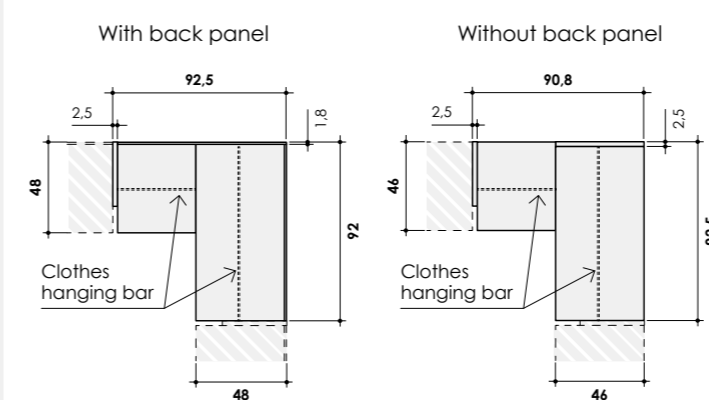

Full corner overall size B

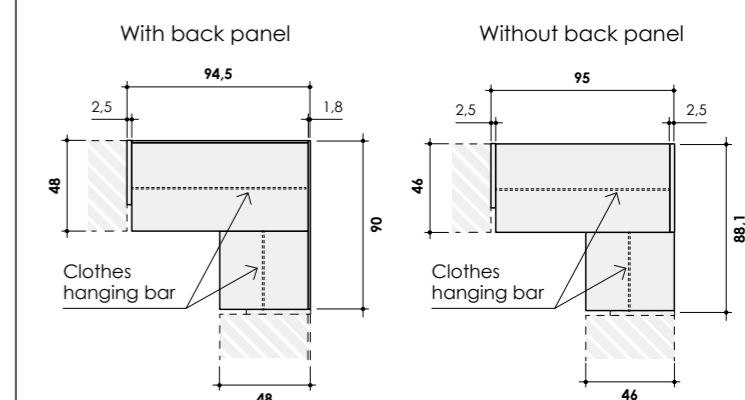

Components in GROUP 2 colors  
AL1A GZ8T

FLEXO walk-in closet

# FLEXO walk-in closet Ht 257.6

Price and equipment shown below refer to simple shelves.  
You cannot alternate modules with back panels and modules without.

With back panel  
Dpt 48

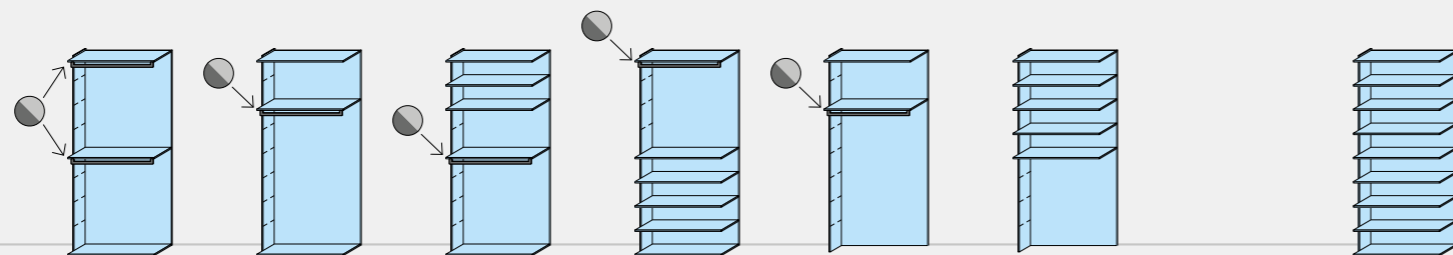

<b>W 47.5</b>	Code	PK28.00Y	PK28.01E	PK28.02M	PK28.03T	PK28.04Z	PK28.05F	PK28.06N						
<b>W 62.5</b>	Code	PK28.07U	PK28.08A	PK28.09G	PK28.10D	PK28.11L	PK28.12S	PK28.13Y						
<b>W 92.5</b>	Code	PK28.14E	PK28.15M	PK28.16T	PK28.17Z	PK28.18F	PK28.19N	PK28.20K						
Custom-made Max 92.4 Min 32.5	Code	-	-	-	-	-	PK28.21R	PK28.22X						

Without back panel  
Dpt 46

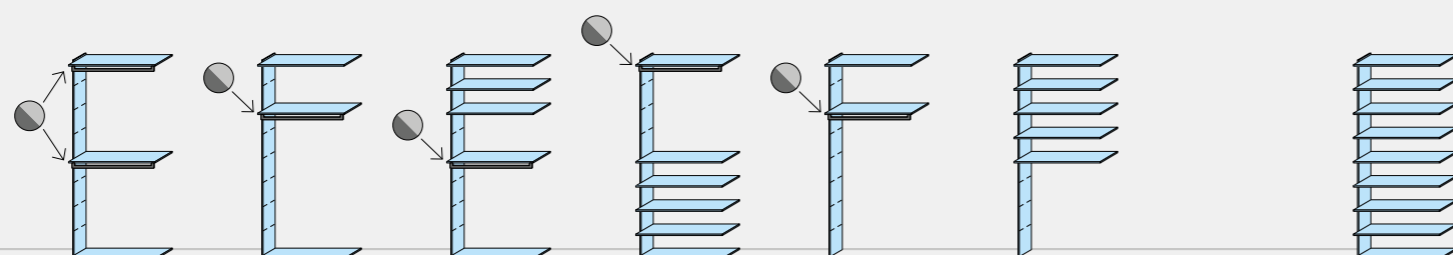

<b>W 47.5</b>	Code	PK28.23D	PK28.24L	PK28.25S	PK28.26Y	PK28.27E	PK28.28M	PK28.29T						
<b>W 62.5</b>	Code	PK28.30Q	PK28.31W	PK28.32C	PK28.33K	PK28.34R	PK28.35X	PK28.36D						
<b>W 92.5</b>	Code	PK28.37L	PK28.38S	PK28.39Y	PK28.40V	PK28.41B	PK28.42H	PK28.43Q						
Custom-made Max 92.4 Min 32.5	Code	-	-	-	-	-	PK28.44W	PK28.45C						

Movable shelves  
Th 2.5 Dpt 45.8

	Simple	With clothes rail	With led	With led and clothes rail	Frame and glass Th 1.8 Maximum recommended load 5 kg	
<b>W 45</b>	Code	PL21.30M	PL21.77D	PL21.33F	PL21.80P	-
<b>W 60</b>	Code	PL21.36A	PL21.78L	PL21.39V	PL21.81V	-
<b>W 90</b>	Code	PL21.42E	PL21.79S	PL21.45Z	PL21.82B	PL21.69M
Custom-made Max 89.9 Min 30	Code	PL21.48U	-	-	-	-

Bottom  
Th 2.5 Dpt 45.8  
with adjustable feet

<b>W 45</b>	Code	PL21.65L
<b>W 60</b>	Code	PL21.66S
<b>W 90</b>	Code	PL21.67Y
Custom-made Max 89.9 Min 30	Code	PL21.68E

Side panel  
Th 2.5 Dpt 33.3 Ht 257.6

<b>Code</b>	PK28.99F
-------------	----------

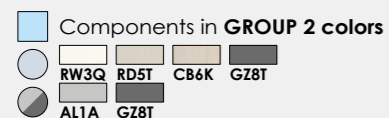

# FLEXO walk-in closet Ht 257.6 - corner units

Price and equipment shown below refer to simple shelves.  
You cannot alternate modules with back panels and modules without.

With back panel  
Dpt 48

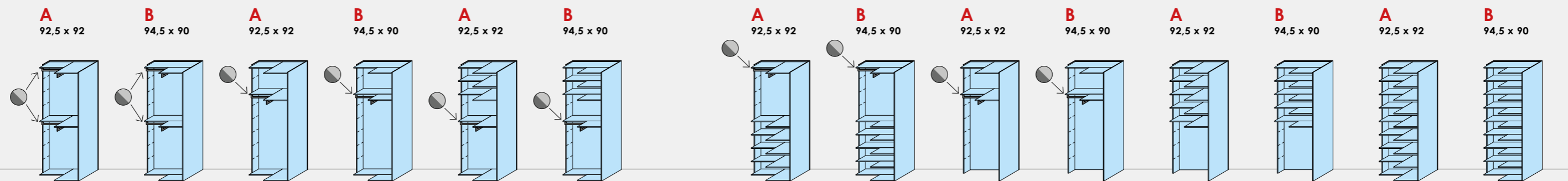

Code	PK49.56A	PK49.57G	PK49.58P	PK49.59V	PK49.60S	PK49.61Y	PK49.62E	PK49.63M	PK49.64T	PK49.65Z	PK49.66F	PK49.67N	PK49.68U	PK49.69A
------	----------	----------	----------	----------	----------	----------	----------	----------	----------	----------	----------	----------	----------	----------

Without back panel  
Dpt 46

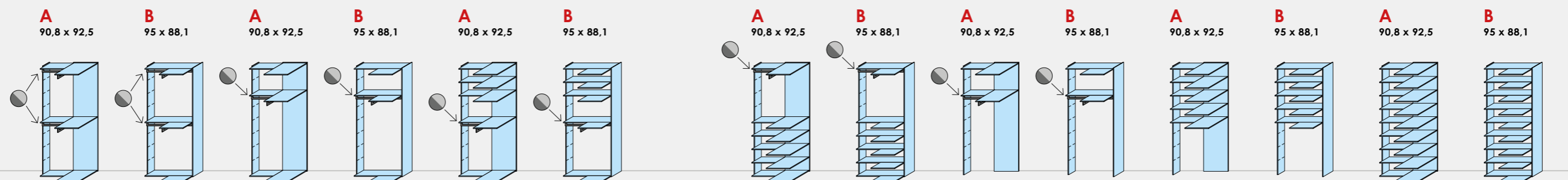

Code	PK49.70X	PK49.71D	PK49.72L	PK49.73S	PK49.74Y	PK49.75E	PK49.76M	PK49.77T	PK49.78Z	PK49.79F	PK49.80C	PK49.81K	PK49.82R	PK49.83X
------	----------	----------	----------	----------	----------	----------	----------	----------	----------	----------	----------	----------	----------	----------

Movable shelves for corner Th 2.5  
(88,1 x 90)

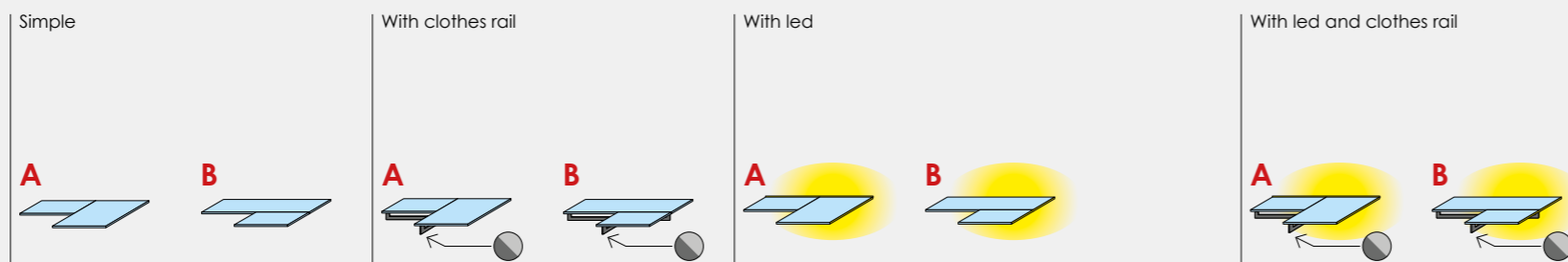

Code	PK26.80H	PK26.81Q	PK26.82W	PK26.83C	PK26.84K	PK26.85R	PK26.86X	PK26.87D						
------	----------	----------	----------	----------	----------	----------	----------	----------	--	--	--	--	--	--

Bottom Th 2.5 Dpt 45.8  
with adjustable feet

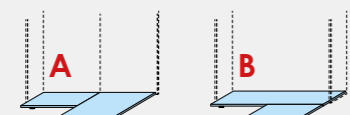

Code	PK26.88L	PK26.89S
------	----------	----------

Side panel Th 2.5 Dpt 33.3 Ht 257.6



Code	PK28.99F
------	----------

Full corner overall size A

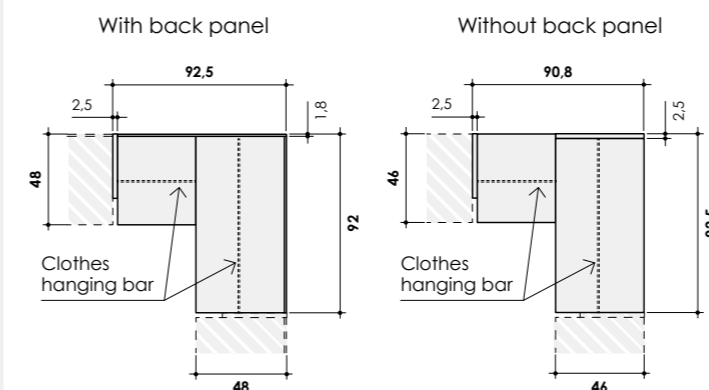

Full corner overall size B

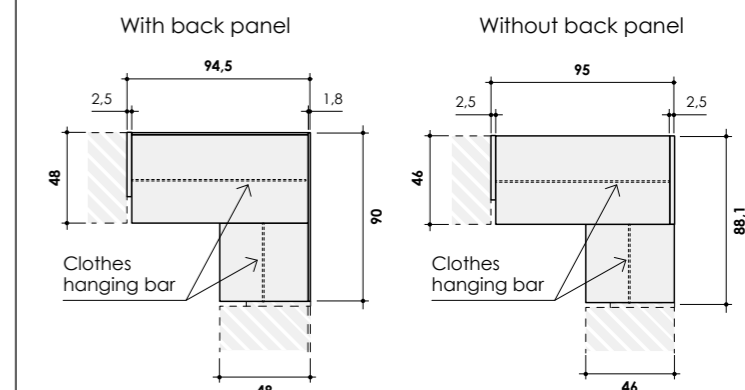

Components in GROUP 2 colors  
AL1A GZ8T

FLEXO walk-in closet

# FLEXO walk-in closet Ht 103 ÷ 302

Side panels are fixed between floor and ceiling

Price and equipment shown below refer to rooms with Ht 233 - 302 and simple shelves.  
You cannot alternate modules with back panels and modules without.

With back panel  
Dpt 48

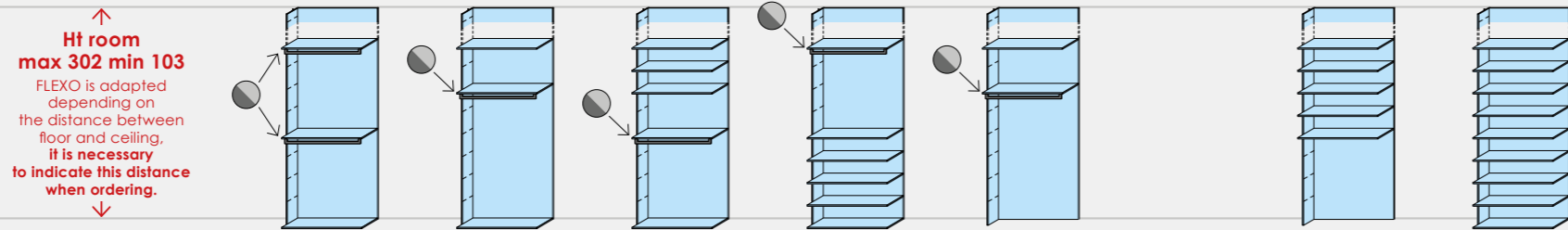

<b>W 47.5</b>	Code	PL21.00V	PL21.01B	PL21.02H	PL21.03Q	PL21.04W	PL21.49A	PL21.50X						
<b>W 62.5</b>	Code	PL21.05C	PL21.06K	PL21.07R	PL21.08X	PL21.09D	PL21.51D	PL21.52L						
<b>W 92.5</b>	Code	PL21.10A	PL21.11G	PL21.12P	PL21.13V	PL21.14B	PL21.53S	PL21.54Y						
Custom-made Max 92.4 Min 32.5	Code	-	-	-	-	-	PL21.55E	PL21.56M						

Without back panel  
Dpt 46

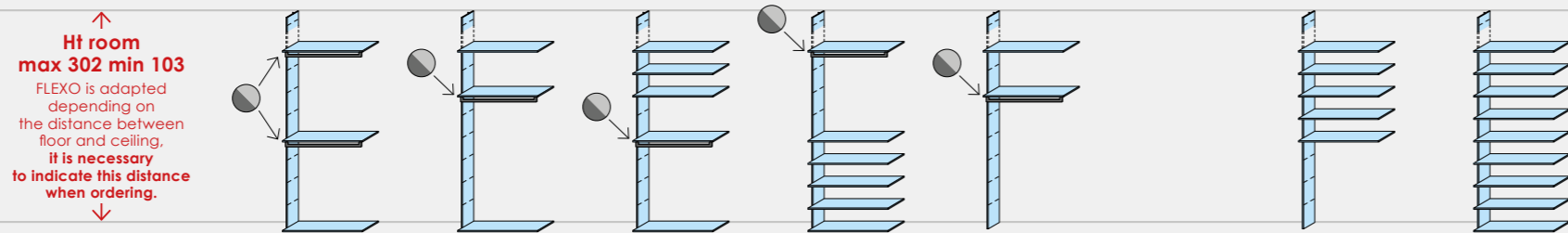

<b>W 47.5</b>	Code	PL21.15H	PL21.16Q	PL21.17W	PL21.18C	PL21.19K	PL21.57T	PL21.58Z						
<b>W 62.5</b>	Code	PL21.20F	PL21.21N	PL21.22U	PL21.23A	PL21.24G	PL21.59F	PL21.60C						
<b>W 92.5</b>	Code	PL21.25P	PL21.26V	PL21.27B	PL21.28H	PL21.29Q	PL21.61K	PL21.62R						
Custom-made Max 92.4 Min 32.5	Code	-	-	-	-	-	PL21.63X	PL21.64D						

Movable shelves  
Th 2.5 Dpt 45.8

	Simple	With clothes rail	With led	With led and clothes rail	Frame and glass Th 1.8 Maximum recommended load 5 kg	
<b>W 45</b>	Code	PL21.30M	PL21.77D	PL21.33F	PL21.80P	-
<b>W 60</b>	Code	PL21.36A	PL21.78L	PL21.39V	PL21.81V	-
<b>W 90</b>	Code	PL21.42E	PL21.79S	PL21.45Z	PL21.82B	PL21.69M
Custom-made Max 89.9 Min 30	Code	PL21.48U	-	-	-	-

Bottom  
Th 2.5 Dpt 45.8  
with adjustable feet

<b>W 45</b>	Code	PL21.65L
<b>W 60</b>	Code	PL21.66S
<b>W 90</b>	Code	PL21.67Y
Custom-made Max 89.9 Min 30	Code	PL21.68E

Customised side panel  
for ceiling fixing  
Th 2.5 Dpt 33.3

	Code	PL21.99C
Ht 103 ÷ 160		
Ht 161 ÷ 232		
Ht 233 ÷ 302		

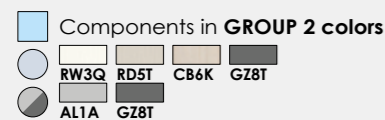

# FLEXO walk-in closet Ht 103 ÷ 302 - corner units

Side panels are fixed between floor and ceiling

Price and equipment shown below refer to rooms with Ht 233 - 302 and simple shelves.  
You cannot alternate modules with back panels and modules without.

**With back panel**  
Dpt 48

Ht room max 302 min 103  
FLEXO is adapted depending on the distance between floor and ceiling. It is necessary to indicate this distance when ordering.

Code	PK27.80N	PK27.81U	PK27.82A	PK27.83G	PK27.84P	PK27.85V	PK27.86B	PK27.87H	PK27.88Q	PK27.89W	PK27.90T	PK27.91Z	PK27.92F	PK27.93N
------	----------	----------	----------	----------	----------	----------	----------	----------	----------	----------	----------	----------	----------	----------

**Without back panel**  
Dpt 46

Ht room max 302 min 103  
FLEXO is adapted depending on the distance between floor and ceiling. It is necessary to indicate this distance when ordering.

Code	PK28.80S	PK28.81Y	PK28.82E	PK28.83M	PK28.84T	PK28.85R	PK28.86F	PK28.87N	PK28.88U	PK28.89A	PK28.90X	PK28.91D	PK28.92L	PK28.93S
------	----------	----------	----------	----------	----------	----------	----------	----------	----------	----------	----------	----------	----------	----------

## Movable shelves for corner Th 2.5 (88,1 x 90)

	Simple	With clothes rail	With led	With led and clothes rail										
Code	PK26.80H	PK26.81Q	PK26.82W	PK26.83C	PK26.84K	PK26.85R	PK26.86X	PK26.87D						

## Bottom Th 2.5 Dpt 45.8 with adjustable feet

**Customised side panel for ceiling fixing**  
Th 2.5 Dpt 33.3

Ht room max 302 min 103

Code	PK26.88L	PK26.89S	PL21.99C
			Ht 103 ÷ 160
			Ht 161 ÷ 232
			Ht 233 ÷ 302

## Full corner overall size A

**Full corner overall size B**

Components in GROUP 2 colors  
AL1A GZ8T

FLEXO walk-in closet

# Accessories for FLEXO walk-in closet

For niche  
W 60

**Cantilever clothes rail**  
Ht 84

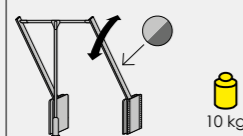

**P02.60X**

**Fabric pull-out laundry basket**  
Dpt 46.5  
Ht 41.5

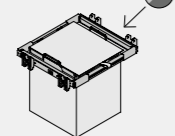

**P02.80F**

**Pull-out pant rack**  
Dpt 46.5  
Ht 8

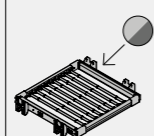

**P02.86P**

For niche  
W 90

**Cantilever clothes rail**  
Ht 84

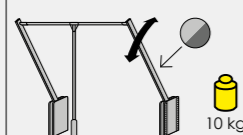

**P02.58M**

**2 pull-out fabric laundry baskets**  
Dpt 46.5  
Ht 41.5

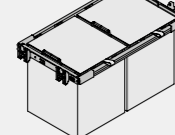

**P02.81M**

**Pull-out shoe rack**  
Dpt 46.5  
Ht 17.2

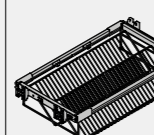

**P02.82S**

**Metal pull-out basket**  
Dpt 46.5  
Ht 12.4

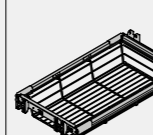

**P02.83X**

**Pull-out pant rack**  
Dpt 46.5  
Ht 8

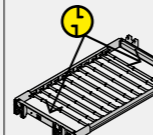

**P02.84C**

**Pull-out tie/belt rack + pant rack**  
Dpt 46.5  
Ht 8

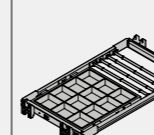

**P02.85H**

**Tie rack hooks**  
Can be inserted where the icon is shown  
W 42

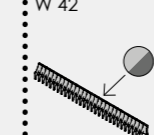

**P07.12C**

**Coin tray**  
Can be inserted where the icon is shown  
W 42

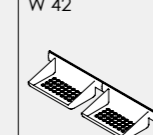

**P07.13H**

Example of pant rack with tie rack hooks and coin tray.

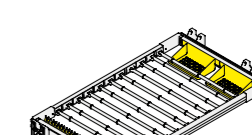

For niche  
W 90

**Drawer units Dpt 45.8 (the back is properly finished)**  
Provided with "Quadro" metal runners which have PUSH-PULL opening.  
Drawers internal color CHARM.  
The drawer units can be placed on the floor or suspended with fixing to the sides.

Drawers Ht 15.6 with frame and glass. Glass top.

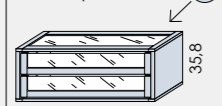

**PL21.70H**

Drawers Ht 15.6 with frame and glass. Glass top.

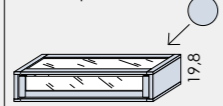

**PL21.71Q**

Drawers Ht 15.6 with frame and glass.

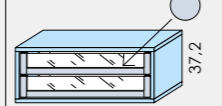

**PL21.72W**

**Bring objects**  
plasticized partition in soft-touch finish for interior drawers with frame and glass  
W 82  
Dpt 38.5  
Ht 7

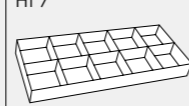

**PL21.73C**

**Metal clothes reacher pole**  
Ht 115

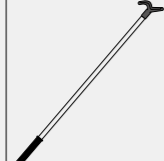

**PL04.17C**

**Sliding clothes rail**

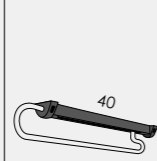

**P50.95S**

**Led spotlights Ø 6.5**  
We provide a power pack (with a surcharge) able to support from 1 to 6 spotlights.  
12 volt 1.7 watt.



**PL86.17N**

**Wireless switch**  
For led lighting (usable for shelves and for spotlight).



**PL86.18U**

**Shoe rack (inclined plane)**  
Dpt 45.8  
Th 2.5  
Dedicated drilling on the side panels

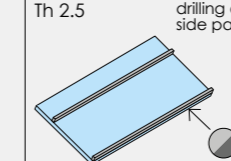

**PK01.93E**

W 45

Code

**PK01.93E**

W 60

Code

**PK01.94M**

W 90

Code

**PK01.95T**

Components in **GROUP 2 colors**

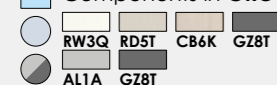



GROUP 1 colors	Rovere Dorian <b>RD5T</b>	Rovere white <b>RW3Q</b>	Noce naturale <b>NN7H</b>	Eucalipto <b>CL1X</b>	Domy <b>DM7P</b>	Bianco UV <b>BU3Q</b>
	Ciliegio bianco <b>CB6K</b>	Malta <b>ML7H</b>	Feltro <b>FL8X</b>	Cemento Masdar <b>CM3Q</b>	Blu indaco <b>BI4B</b>	
	Noce <b>NC4B</b>	Desert <b>DS9L</b>	Canapa <b>CN1X</b>	Moka <b>MK6B</b>	Cipria <b>CP4J</b>	
	Bianco opaco <b>BI7A</b>	Grigio Dorian <b>GL4R</b>	Basalto <b>BS5T</b>	Grigio titanio <b>GZ8T</b>	Rosa bubble <b>RB7Y</b>	
	Agave <b>GV7A</b>	Verde Alpi <b>VA5T</b>	Cadaques <b>CQ3Q</b>	Giallo zafferano <b>GZ8A</b>		
	Blu opale <b>BO7H</b>			Corallo <b>CR5T</b>		

**Types and colors FRONT**

**ONE**  
matte  
glossy

Rovere white <b>RW3Q</b>	Rovere Dorian <b>RD5T</b>	Ciliegio bianco <b>CB6K</b>	Noce naturale <b>NN7H</b>	Noce <b>NC4B</b>	Eucalipto <b>CL1X</b>	Malta <b>ML7H</b>
Feltro <b>FL8X</b>	Cemento Masdar <b>CM3Q</b>	Bianco opaco <b>BI7A</b>	Desert <b>DS9L</b>	Canapa <b>CN1X</b>	Moka <b>MK6B</b>	Grigio Dorian <b>GL4R</b>
Basalto <b>BS5T</b>	Grigio titanio <b>GZ8T</b>	Domy <b>DM7P</b>	Agave <b>GV7A</b>	Verde Alpi <b>VA5T</b>	Cadaques <b>CQ3Q</b>	Blu indaco <b>BI4B</b>
Blu opale <b>BO7H</b>	Cipria <b>CP4J</b>	Rosa bubble <b>RB7Y</b>	Giallo zafferano <b>GZ8A</b>	Corallo <b>CR5T</b>		

Bianco UV  
**BU3Q**

**CLUB**

Specify the color of the CLUB handle

Bianco opaco <b>BI7A</b>	Desert <b>DS9L</b>	Canapa <b>CN1X</b>	Moka <b>MK6B</b>	Grigio Dorian <b>GL4R</b>	Basalto <b>BS5T</b>	Grigio titanio <b>GZ8T</b>
Domy <b>DM7P</b>	Agave <b>GV7A</b>	Verde Alpi <b>VA5T</b>	Cadaques <b>CQ3Q</b>	Blu indaco <b>BI4B</b>	Blu opale <b>BO7H</b>	Cipria <b>CP4J</b>
Rosa bubble <b>RB7Y</b>	Giallo zafferano <b>GZ8A</b>	Corallo <b>CR5T</b>				

**WINDOW**

Trasparente  
**TR9M**

Trasparente fumé  
**FT8P**

Stop-sol  
**ST6P**

Specchio  
**SP7L**

Specify the color of the aluminum frame

Alluminio <b>AL1A</b>	Titan grey <b>TG7H</b>
--------------------------	---------------------------

**Bridge units - Corner bridge unit**

RIALTO bridge unit Dpt 56.3 - technical information	266
OPTIONAL for RIALTO bridge unit	268
Wardrobes with shaped side panels Ht 225.6 - Dpt 56.3	270
Wardrobes with shaped side panels Ht 241.6 - Dpt 56.3	271
Wardrobes with shaped side panels Ht 257.6 - Dpt 56.3	272
Accessories for wardrobe with shaped side panels Dpt 56.3	273
RIALTO bridge unit Ht 96 - Dpt 56.3	274
RIALTO bridge unit Ht 112 - Dpt 56.3	275
RIALTO bridge unit Ht 128 - Dpt 56.3	276
Accessories for RIALTO bridge unit Dpt 56.3	277
RIALTO bridge unit Ht 96 - Dpt 56.3 with oblique cut doors	278
RIALTO bridge unit W 210 - Dpt 56.3 with bellow doors	279
RIALTO corner bridge unit Dpt 56.3	280
Over-bar wardrobe for RIALTO bridge unit Dpt 56.3	282
Elements for RIALTO bridge unit Dpt 56.3	284

# RIALTO bridge unit Dpt 56.3 - technical information

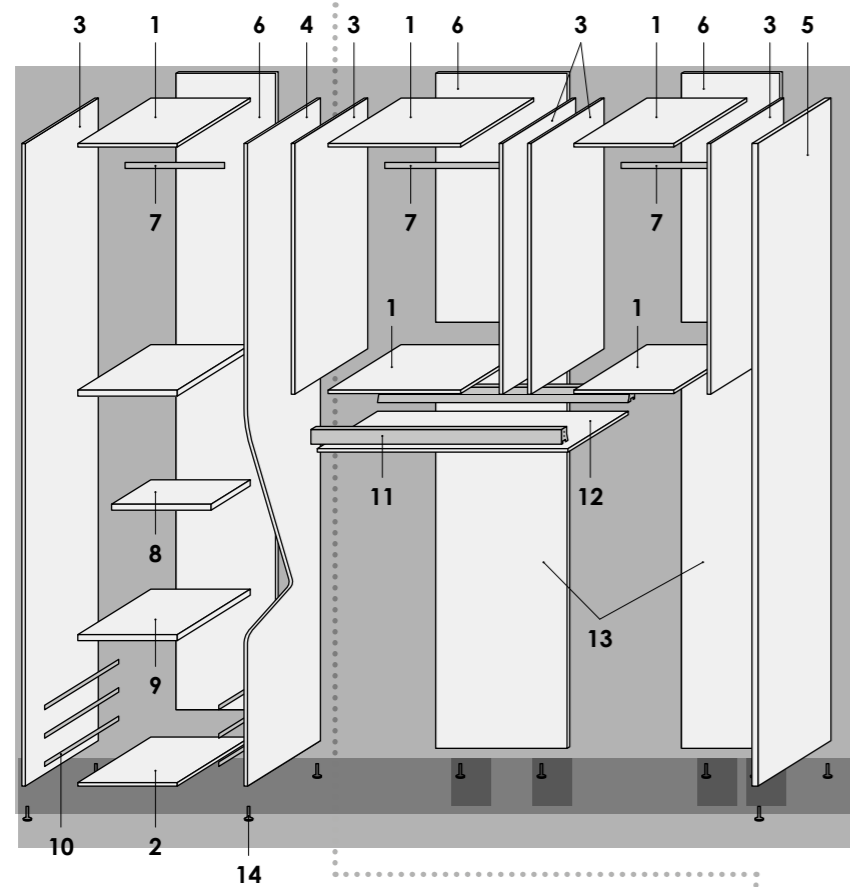

## Components:

- 1 Top panel Th 1.8 - With eccentric pin system
- 2 Bottom panel Th 1.8 - With eccentric pin system
- 3 Side panels Th 1.8 - With prefitted hardware.
- 4 Shaped side panel Th 1.8 - With prefitted hardware.
- 5 Side support panels Th 2.5
- 6 Back panel Th 0.3 or 0.8 (optional) - Fitting into shaped connection.
- 7 BASIC clothes hanging bar in chromed metal  
PLUS clothes hanging bar (optional) in aluminum.
- 8 Shelf for open-plan compartment Th 2.5 Dpt 28.6 - On runner.
- 9 Dividing movable shelf Th 2.5 Dpt 53 - With sliding support.
- 10 Metal drawer runners
- 11 Metal bars
- 12 Panel compartment for inspection
- 13 Back panels (optional)
- 14 Adjustable middle-support feet

## Wardrobes with shaped side panels

Dimensions:

W 45 - 60 - 90

Dpt 56,3

Ht 225,6 - 241,6 - 257,6

- These structures can only be placed on the ground.
- The side panels are flush with the top and bottom and have custom holes.
- The hardware is placed in a personalized fashion according to the position of the components.
- Tops are not finished.
- They are equipped with adjustable feet.
- The doors are fitted with decelerated hinges.
- The drawers and big drawer CLUB are always fitted with height-adjustable, soft-close, Quadro, metal slides with interior CHARM finish.
- **Internal equipment included:** 1 x clothes rail.
- **For custom cuts consult the relevant chapter.**
- In the 90-wide elements with 30 + 60-cm wide doors, the direction is determined by the position of the 60-cm wide door.
- On request, the doors can be supplied without a handle and holes for the handle (Not CLUB doors).
- The Wardrobes with pairs of CLUB doors are provided with only one handle. In elements with doors W 30 + 60 the handle is placed on the W 60 door. Upon customer's request the CLUB handle can be mounted on both doors.
- **Shelf with led for open-plan compartment:** The lighting consists of a led strip (60 leds/m) placed on the rear of the shelf. The strip is the same length as the shelf and lights the upper and lower compartment by reflecting in the backboard. The type of lighting is natural. A power supply unit is supplied (with surcharge) that can power from 1 to 6 shelves x 45/60-cm wide or 1 to 4 x 90-cm wide shelves. It can be switched on in 2 ways: by plugging it in and using the wall switch or by ordering a wireless switch from the price list.

## RIALTO bridge unit

Dimensions:

W 30 - 45 - 60 - 90

Dpt 56,3

Ht 96 - 112 - 128

- The wall-mounted elements must be assembled using the hardware provided.
- The doors are with decelerated hinges.
- **Internal equipment included:** 1 clothes hanging bar for every niche.
- **For custom cuts consult the relevant chapter.**
- In units W 90 with doors W 30 + W 60 the direction is determined by the position of the door W 60.
- Upon request, the doors can be supplied without a handle and without handle holes (Not CLUB doors).
- The elements with pairs of CLUB doors are provided with only one handle. In elements with doors W 30 + W 60 the handle is placed on the W 60 door. Upon customer's request the CLUB handle can be mounted on both doors.
- **Compositions must be completed with Wardrobes, the Side support panel or SMART support bookcases.**
- **For correct arrangement of the elements, it is essential to send a design of the complete overhead structure. The support elements have customised holes in the metal bars every 32 cm at a height of 131 cm from the ground.**
- The use of rear panels is optional, except for corner overhead structures.
- The effective depth of the under-overhead compartment, in the presence of rear panels, is reduced by 4 cm (56.3 - 4 = 52.3 cm).

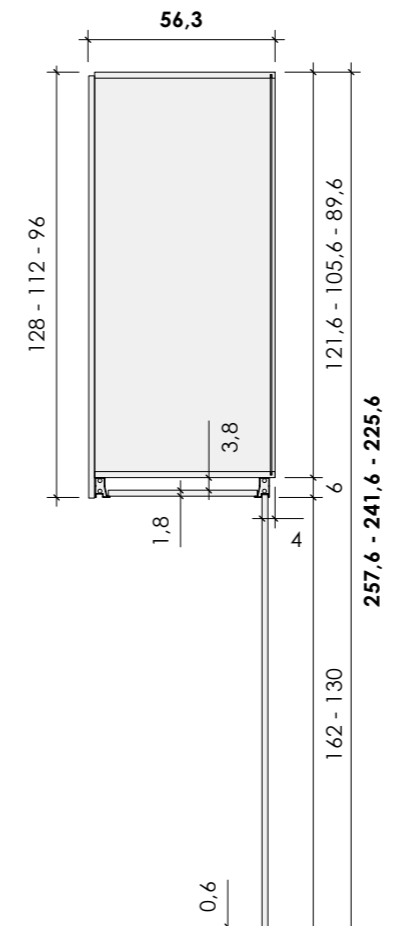

## RIALTO over-bar wardrobe with bellow doors

Dimensions:

W 210

Dpt 56,3

Ht 96 - 112 - 128

- The elements must be secured to the wall using the supplied hardware.
- **Internal equipment included:** 1 clothes hanging bar for every niche.
- **Custom cuts are not envisaged.**
- **Compositions must be completed with Wardrobes, the Side support panel or SMART support bookcases.**
- **For correct arrangement of the elements, it is essential to send a design of the complete overhead structure. The support elements have customised holes in the metal bars every 32 cm at a height of 131 cm from the ground.**
- They are always equipped with a rear panel.
- The effective depth of the under-overhead compartment is 52,3 cm.

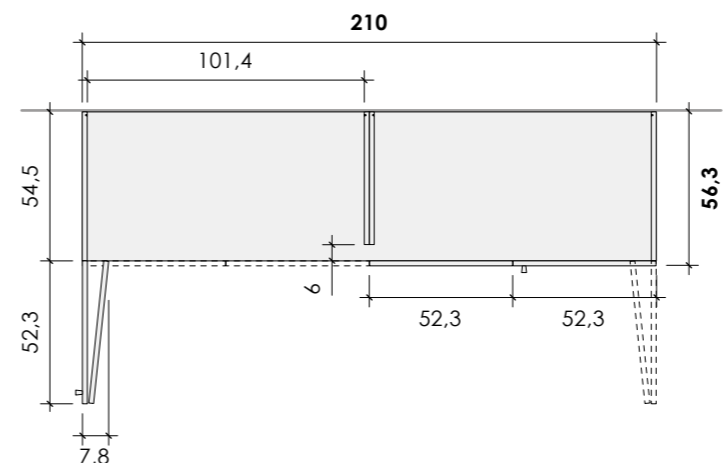

## Examples of RIALTO overhead linear wardrobe

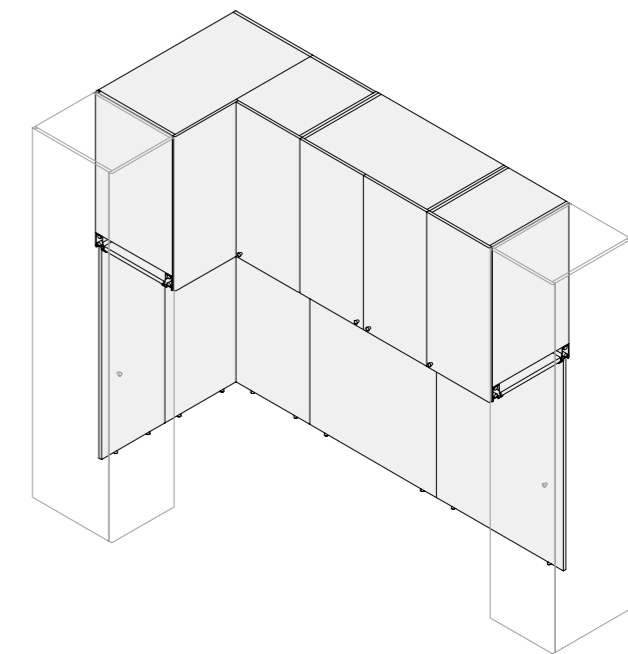
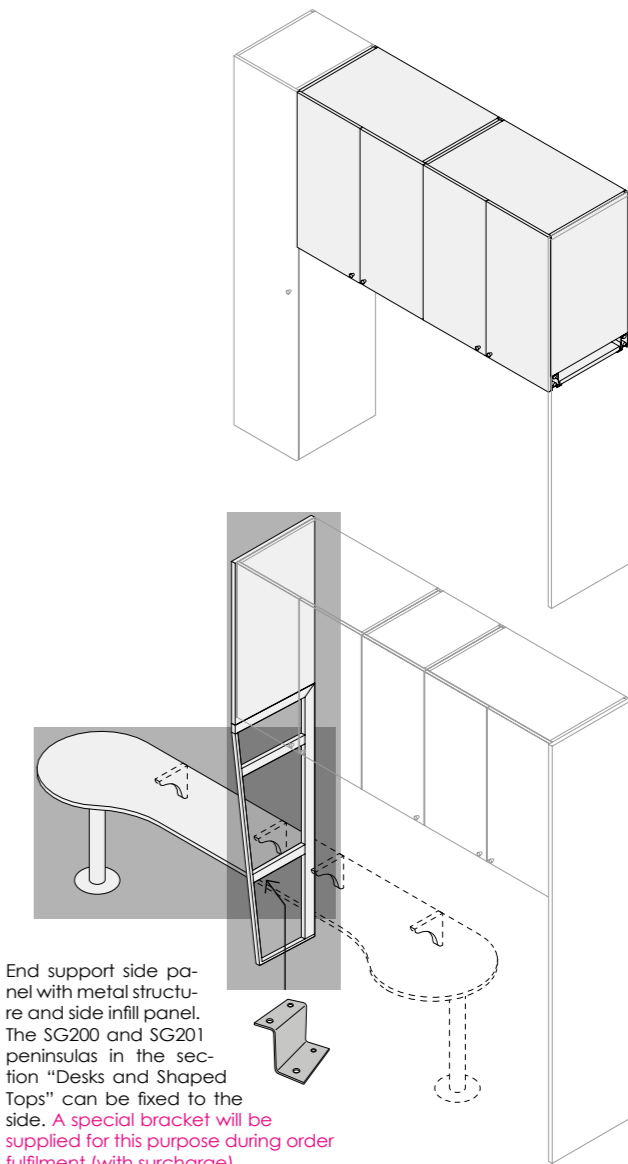

Bridge units  
Corner bridge unit

## OPTIONAL for RIALTO bridge unit

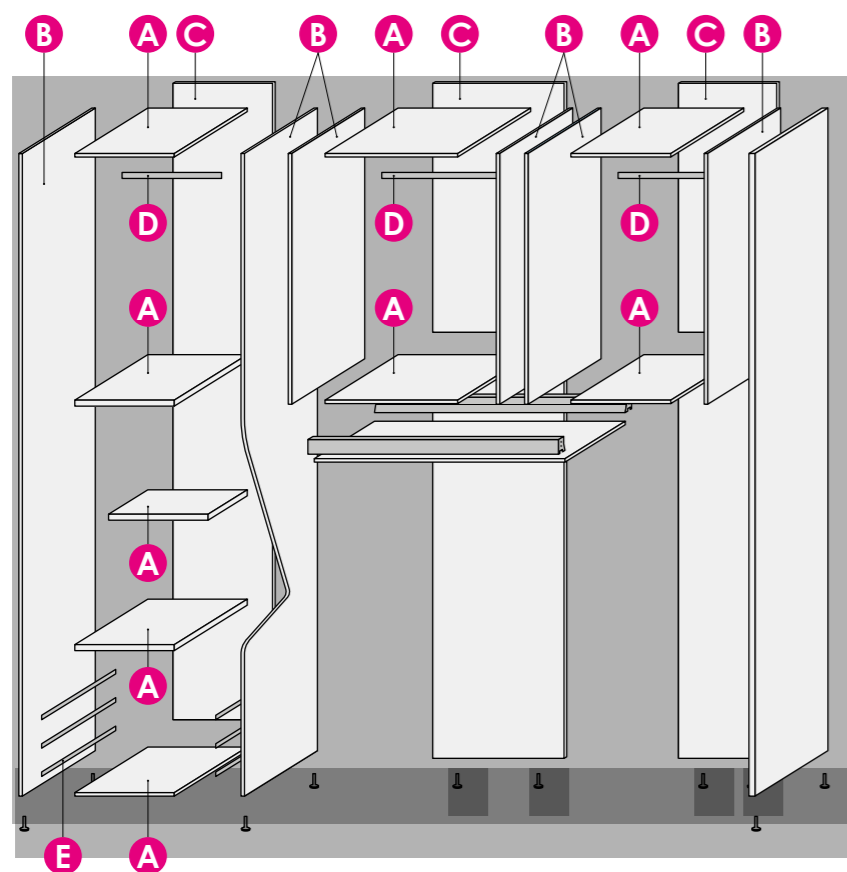

### A Extra colors for Top panel, Bottom panel and Shelves

In addition to the standard CARCASE colors, these components are all available in the GROUP 2 colors with surcharge (see table).

- **When placing the order:** indicate the colour in the HORIZONTAL FINISHES variant in Metron 4: all top panels, bottom panels and shelves will automatically be delivered in that colour (if specified, the various elements can be coloured as preferred).
- **N.B.** The surcharge is applied to each single component.

Top panel Bottom panel Shelves	Surcharge for single element (CARCASE colors excluded)
W 30	
W 45	
W 60	
W 90	
W 105*	
Corner Bridge units	
Shelf Dpt 28.6 for Wardrobes with shaped side panels	W 45 W 60 W 90

\* For Bridge unit with bellow doors

### B Extra colors for Side panels

In addition to the standard CARCASE colors, the side panels are available in all the GROUP 2 colors with surcharge (see table).

- **When placing the order:** indicate the colour in the COLOURED FINISHES variant in Metron 4: all side panels will automatically be delivered in that colour (if specified, 1, 2 or more side panels can be coloured as preferred).

Side panel	Surcharge for single element (CARCASE colors excluded)
Wardrobe	
Ht 225,6	
Ht 241,6	
Ht 257,6	
Bridge units	
Ht 96	
Ht 112	
Ht 128	

### C Increased Back panel Th 0.8

On request the Wardrobe can be equipped with a back panel Th 0.8 with surcharge (see table), in replacement of the standard back panel Th 0.3; unlike the standard one (available in the CARCASE colors), the increased back panel is available in all GROUP 2 colors.

- **When placing the order:** indicate YES for increased back panel in the BACK PANEL TYPE variant and the colour in the BACK PANEL COLOUR variant in Metron 4: all back panels will automatically be supplied in the same type and colour (if specified, it is possible to change the back panel type and colour of the various elements as preferred).
- **N.B.** The surcharge is applied to each back panel.

Back panel Th 0.8	Surcharge for single element
Wardrobe	Ht 225,6 - 241,6 - 257,6
W 45	
W 60	
W 90	
Bridge units	Ht 96 - 112 - 128
W 30	
W 45	
W 60	
W 90	
W 105*	
Corner Bridge units	

\* For Bridge unit with bellow doors

### D PLUS clothes-hanging bar

On request the wardrobe can be equipped with PLUS clothes-hanging bars with surcharge (see table). The PLUS clothes-hanging bar is in aluminium Ø 2.8, available in the Alluminio (AL1A) and Grigio titanio (GZ8T) colors.

- **When placing the order:** indicate PLUS clothes-hanging bar in the BAR TYPE variant and the colour in the BAR COLOUR variant in Metron 4: all bars will automatically be delivered in the same type and same colour.



Clothes-hanging bar	Surcharge for single element
W 30	
W 45	
W 60	
W 90	
W 105*	
Corner bridge unit	

\* For Bridge unit with bellow doors

### E Drawers and big drawers with soft-close

On request drawers and big drawers in the "standard" version can be equipped with soft-close mechanisms, with surcharge (see table). Alternatively, drawers and big drawers can be ordered in the CHARM version, with surcharge (see table), equipped with height-adjustable "Quadro" type runners with prestigious internal finish.

- **When placing the order:** indicate the type of runners in the RUNNER TYPE variant in Metron 4.
- **N.B.** the CLUB drawers and big drawers with soft-close "Quadro" type runners are supplied standard in the CHARM version (without surcharge).

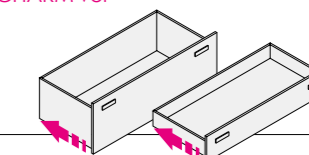

Slow closing	Surcharge for single element
Drawers W 45 - 60 - 90	
Big drawers W 45 - 60 - 90	
CHARM Drawers/Big drawers with soft-close "Quadro" slides W 45 - 60 - 90	

## Wardrobes with shaped side panels Ht 225.6 - Dpt 56.3

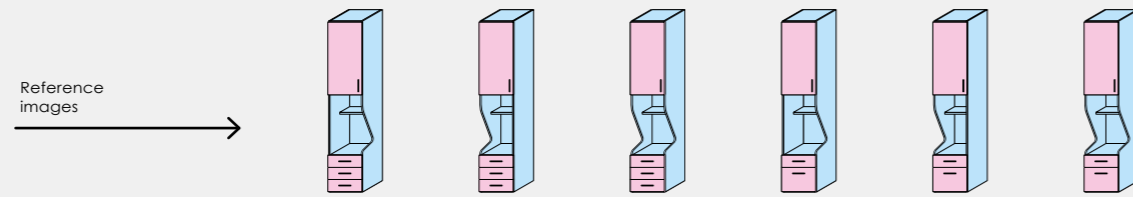

### W 45

Specify hinge  
R or L

Code	PK38.01H	PK38.02Q	PK38.03W	PK38.04C	PK38.05K	PK38.06R
ONE	matte					
	glossy					
CLUB						

### W 60

Specify hinge  
R or L

Code	PK38.07X	PK38.08D	PK38.09L	PK38.10G	PK38.11P	PK38.12V
ONE	matte					
	glossy					
CLUB						

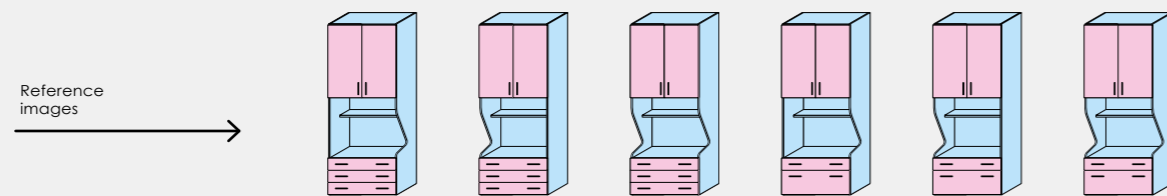

### W 90

Code	PK38.13B	PK38.14H	PK38.15Q	PK38.16W	PK38.17C	PK38.18K
ONE	matte					
	glossy					
CLUB						

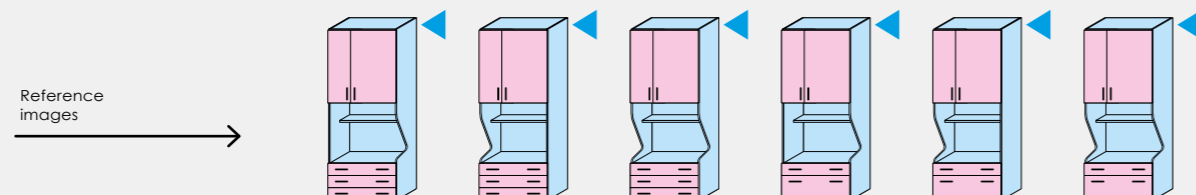

### W 90

Code	PK38.19R	PK38.20N	PK38.21U	PK38.22A	PK38.23G	PK38.24P
ONE	matte					
	glossy					
CLUB						

## Wardrobes with shaped side panels Ht 241.6 - Dpt 56.3

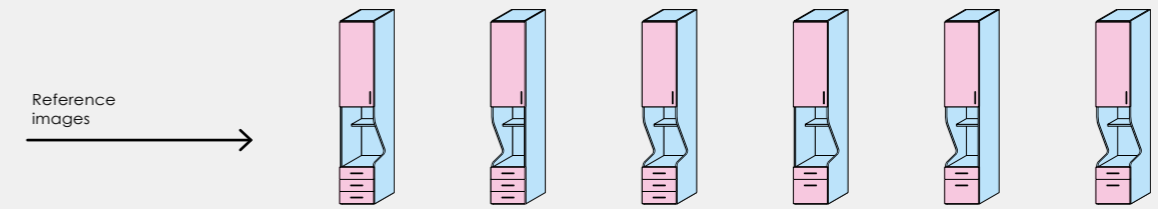

### W 45

Specify hinge  
R or L

Code	PK37.00X	PK37.01D	PK37.02L	PK37.03S	PK37.04Y	PK37.05E
ONE	matte					
	glossy					
CLUB						

### W 60

Specify hinge  
R or L

Code	PK37.06M	PK37.07T	PK37.08Z	PK37.09F	PK37.10C	PK37.11K
ONE	matte					
	glossy					
CLUB						

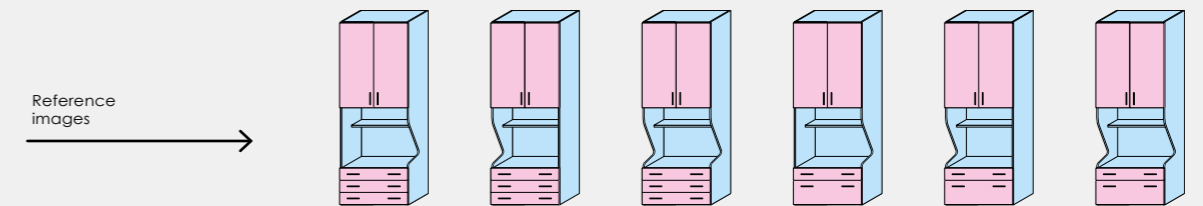

### W 90

Code	PK37.12R	PK37.13X	PK37.14D	PK37.15L	PK37.16S	PK37.17Y
ONE	matte					
	glossy					
CLUB						

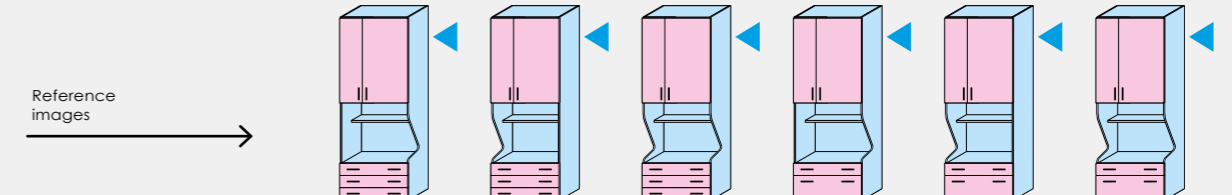

### W 90

Code	PK37.18E	PK37.19M	PK37.20H	PK37.21Q	PK37.22W	PK37.23C
ONE	matte					
	glossy					
CLUB						

Components in **GROUP 2 colors**  
Components in **Types and colors FRONT**

With doors **W 30 + W 60** - Indicate R or L (drawing - R)



**OPTIONAL:**  
p. 268

- A · Extra colors for Top panel, Bottom panel and Shelves
- B · Extra colors for Side panels
- C · Increased back panel Th 0.8
- D · PLUS clothes rail
- E · Drawers and big drawers with soft-close

**CLUB**  
drawers and big drawers  
CHARM with soft-close "Quadro"  
type slides as standard  
(without surcharges)

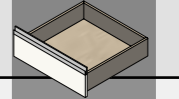

p. 56 Knob and handle positions  
p. 273 Accessories for Wardrobe with shaped side panels Dpt 56.3

Bridge units  
Corner bridge unit

# Wardrobes with shaped side panels Ht 257.6 - Dpt 56.3

# Accessories for wardrobe with shaped side panels Dpt 56.3

## W 45

Specify hinge  
R or L

Reference images →

Code	PK38.25V	PK38.26B	PK38.27H	PK38.28Q	PK38.29W	PK38.30T
ONE	matte					
	glossy					
CLUB						

## W 60

Specify hinge  
R or L

Code	PK38.31Z	PK38.32F	PK38.33N	PK38.34U	PK38.35A	PK38.36G
ONE	matte					
	glossy					
CLUB						

## W 90

Reference images →

Code	PK38.37P	PK38.38V	PK38.39B	PK38.40Y	PK38.41E	PK38.42M
ONE	matte					
	glossy					
CLUB						

## W 90

Reference images →

Code	PK38.43T	PK38.44Z	PK38.45F	PK38.46N	PK38.47U	PK38.48A
ONE	matte					
	glossy					
CLUB						

### Movable shelves

Dpt 51,5  
Th 2,5

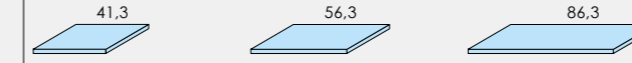

Code	PK01.01T	PK01.02Z	PK01.03F			
	*					

### Shelf with led for open-plan compartment

Dpt 27,6  
Th 2,5

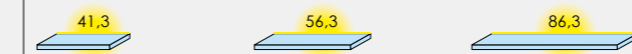

### Wireless switch

For led lighting

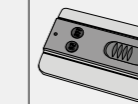

Code	PK01.38E	PK01.39M	PK01.40H	PL86.18U		
	*					

### BASIC clothes-hanging bars

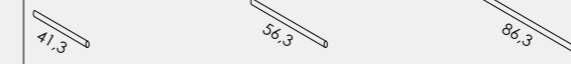

### PLUS clothes-hanging bars

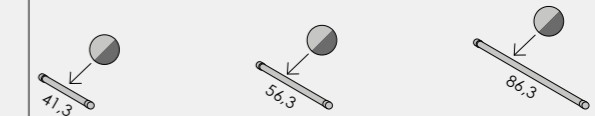

Code	P50.79E	P26.49E	P50.81R	PK01.43C	PK01.44K	PK01.45R

### Metal clothes reacher stick

Ht 115

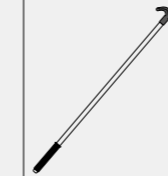

### Cantilever clothes rail

Ht 84

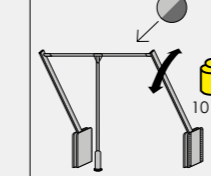

Code	PL04.17C	P02.58M				

Components in **GROUP 2 colors**  
Components in **Types and colors FRONT**  
AL1A GZ8T

\* Price of the element in the GROUP 2 colors (CARCASE colors excluded)  
With doors **W 30 + W 60** - Indicate R or L (drawing - R)



**OPTIONAL:**  
A · Extra colors for Top panel, Bottom panel and Shelves  
B · Extra colors for Side panels  
C · Increased back panel Th 0.8  
D · PLUS clothes rail  
E · Drawers and big drawers with soft-close

CLUB  
drawers and big drawers  
CHARM with soft-close "Quadro"  
type slides as standard  
(without surcharges)

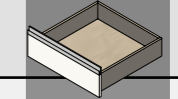

p. 56 Knob and handle positions

Bridge units  
Corner bridge unit



## RIALTO bridge unit Ht 96 - Dpt 56.3

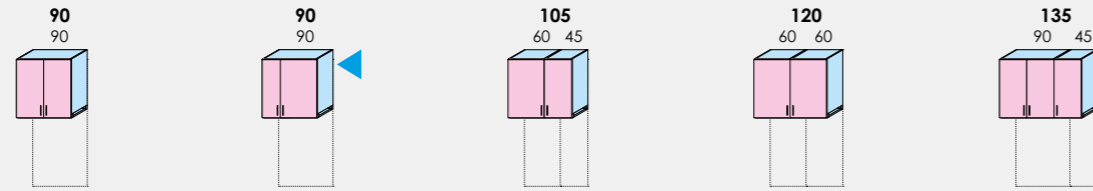

Code	PK38.51L	PK38.52S	PK38.53Y	PK38.54E	PK38.55M
ONE	matte				
	glossy				
CLUB					

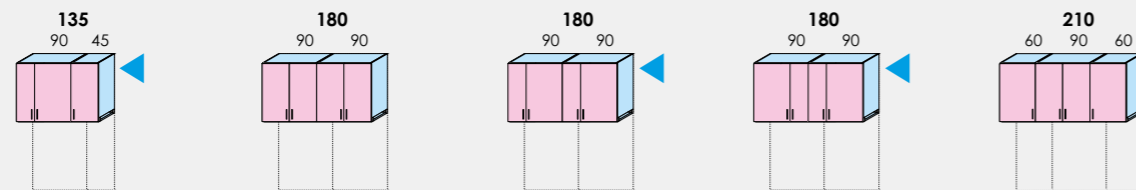

Code	PK38.56T	PK38.57Z	PK38.58F	PK38.59N	PK38.60K
ONE	matte				
	glossy				
CLUB					

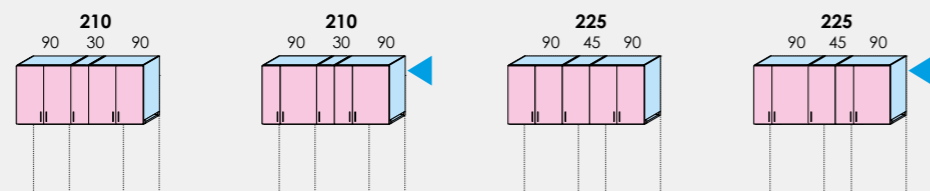

Code	PK38.61R	PK38.62X	PK38.63D	PK38.64L	
ONE	matte				
	glossy				
CLUB					

## RIALTO bridge unit Ht 112 - Dpt 56.3

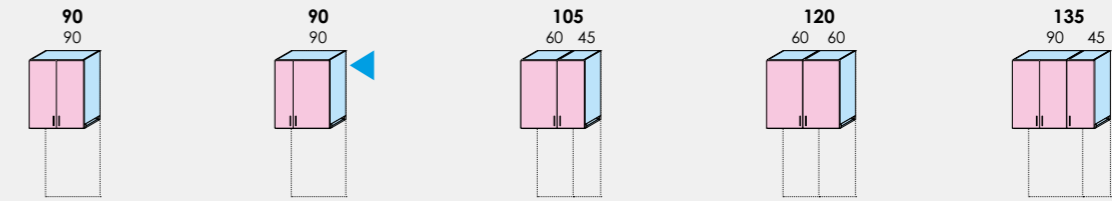

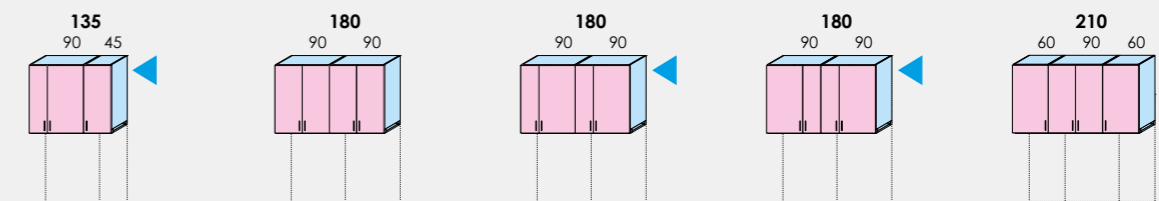

Code	PK37.30P	PK37.31V	PK37.32B	PK37.33H	PK37.34Q
ONE	matte				
	glossy				
CLUB					

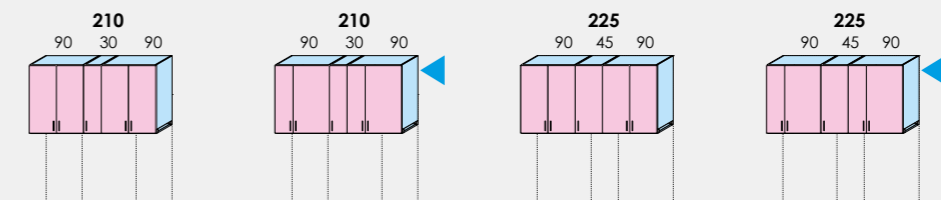

Code	PK37.35W	PK37.36C	PK37.37K	PK37.38R	PK37.39X
ONE	matte				
	glossy				
CLUB					



Code	PK37.40U	PK37.41A	PK37.42G	PK37.43P	
ONE	matte				
	glossy				
CLUB					

 Components in **GROUP 2 colors**  
 Components in **Types and colors FRONT**

 With doors **W 30 + W 60** - Indicate R or L (drawing - R)

 **OPTIONAL:** p. 268  
**A** · Extra colors for Top panel, Bottom panel and Shelves  
**B** · Extra colors for Side panels  
**C** · Increased back panel Th 0.8  
**D** · PLUS clothes rail

Metal supporting bars  
 available in the colors:  
 Bianco opaco (B17A)  
 Alluminio (A11A)

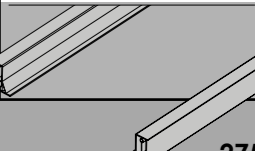



# RIALTO bridge unit Ht 128 - Dpt 56.3

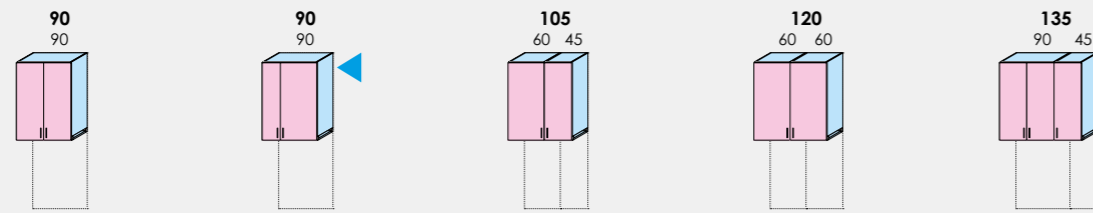

Code	PK38.65S	PK38.66Y	PK38.67E	PK38.68M	PK38.69T
ONE	matte				
	glossy				
CLUB					

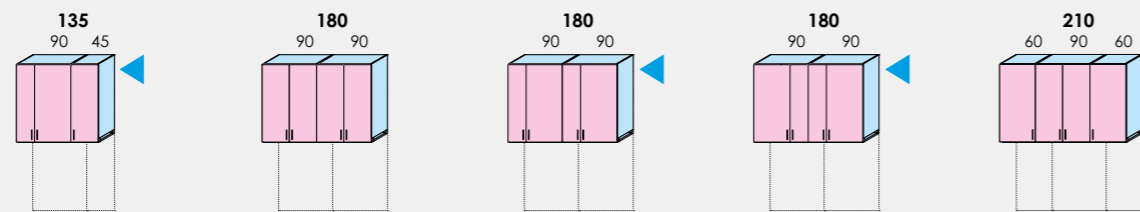

Code	PK38.70Q	PK38.71W	PK38.72C	PK38.73K	PK38.74R
ONE	matte				
	glossy				
CLUB					

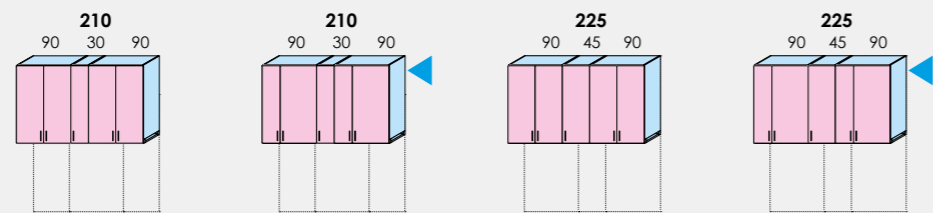

Code	PK38.75X	PK38.76D	PK38.77L	PK38.78S
ONE	matte			
	glossy			
CLUB				

# Accessories for RIALTO bridge unit Dpt 56.3

## Movable shelves

Th 2.5

Dpt 53

26.3

Dpt 51.5

41.3

56.3

86.3

Code	PK01.05U	PK01.01T	PK01.02Z	PK01.03F
	*			

## BASIC clothes-hanging bars

26.3

41.3

56.3

86.3

Code	P08.00R	P50.79E	P26.49E	P50.81R

## PLUS clothes-hanging bars

26.3

41.3

56.3

86.3

Code	PK01.42W	PK01.43C	PK01.44K	PK01.45R

## Metal clothes reacher stick

Ht 115

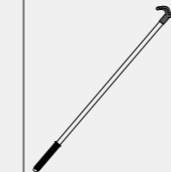

## Cantilever clothes rail

Ht 84

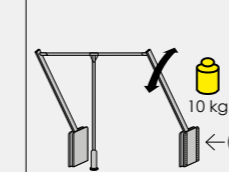

Code	PL04.17C	P02.58M

Components in **GROUP 2 colors**  
 Components in **Types and colors FRONT**  
 AL1A GZ8T

\* Price of the element in the GROUP 2 colors (CARCASE colors excluded)  
 With doors W 30 + W 60 - Indicate R or L (drawing - R)



**OPTIONAL:**  
 A · Extra colors for Top panel, Bottom panel and Shelves  
 B · Extra colors for Side panels  
 C · Increased back panel Th 0.8  
 D · PLUS clothes rail

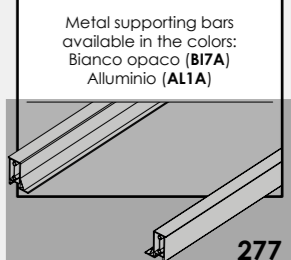

# RIALTO bridge unit Ht 96 - Dpt 56.3 with oblique cut doors

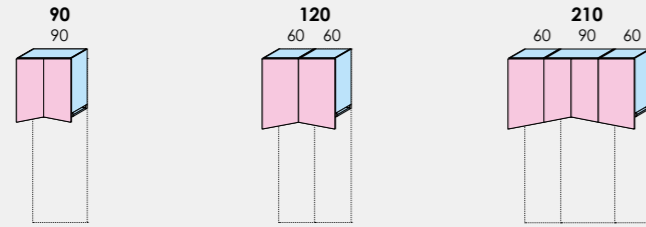

<b>Code</b>	<b>PK38.94B</b>	<b>PK38.95H</b>	<b>PK38.96Q</b>		
ONE	matte				
	glossy				

# RIALTO bridge unit W 210 - Dpt 56.3 with bellow doors

## Ht 225.6

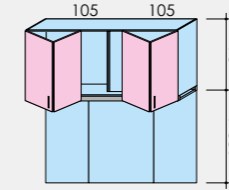

<b>Code</b>	<b>PK38.79Y</b>				
ONE	matte				
	glossy				

## Ht 241.6

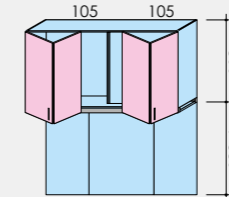

<b>Code</b>	<b>PK37.50Z</b>				
ONE	matte				
	glossy				

## Ht 257.6

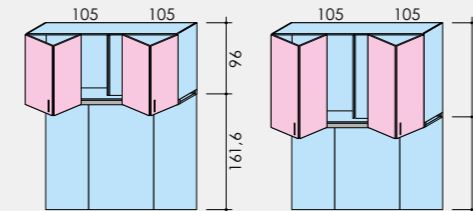

<b>Code</b>	<b>PK38.80V</b>	<b>PK38.93V</b>			
ONE	matte				
	glossy				

### Movable shelves

Th 2,5

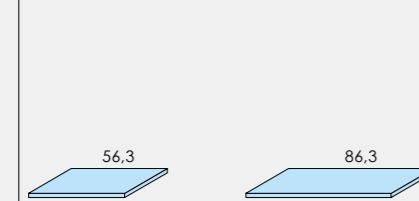

### BASIC clothes-hanging bars

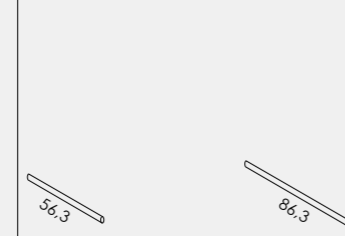

### PLUS clothes-hanging bars

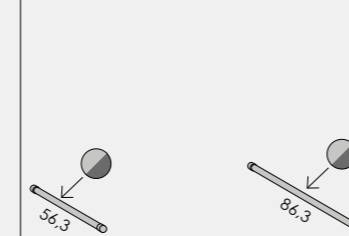

<b>Code</b>	<b>PK01.02Z</b>	<b>PK01.03F</b>	<b>P26.49E</b>	<b>P50.81R</b>	<b>PK01.44K</b>	<b>PK01.45R</b>
	*					

### Metal clothes reacher stick

Ht 115



### Cantilever clothes rail

Ht 84

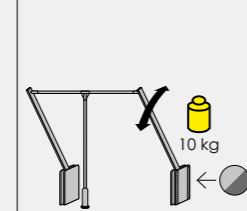

<b>Code</b>	<b>PL04.17C</b>	<b>P02.58M</b>				

- Components in **GROUP 2 colors**
- Components in **Types and colors FRONT**
- AL1A GZ8T

\* Price of the element in the GROUP 2 colors (CARCASE colors excluded)



- OPTIONAL:**  
p. 268
- A · Extra colors for Top panel, Bottom panel and Shelves
  - B · Extra colors for Side panels
  - C · Increased back panel Th 0.8
  - D · PLUS clothes rail

Metal supporting bars  
available in the colors:  
Bianco opaco (B17A)  
Alluminio (AL1A)

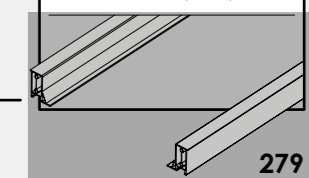

p. 56 Knob and handle positions

# RIALTO corner bridge unit Dpt 56.3

**CUSTOM-MADE corner overhead structures**  
 When creating a custom-made overhead structure:  
 1) Use the code marked \*.  
 2) State the R and L overall dimensions required (X).  
 3) Send a drawing of the complete composition.  
 Limit dimensions: **Min. 99.6 x 101.3 - Max. 279.6 x 281.3**

## Ht 241.6

Over-bar wardrobe  
 Ht 112  
 Niche  
 Ht 129.6

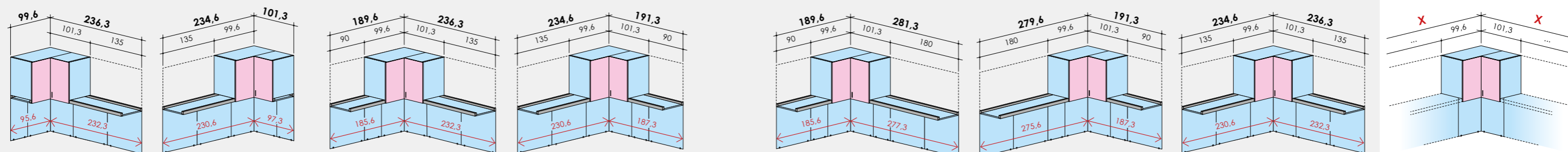

<b>Code</b>	PK39.33S	PK39.34Y	PK39.35E	PK39.36M	PK39.37T	PK39.38Z	PK39.39F	PK39.30X *
ONE	matte							
	glossy							
CLUB								

## Ht 257.6

Over-bar wardrobe  
 Ht 96  
 Niche  
 Ht 161.6

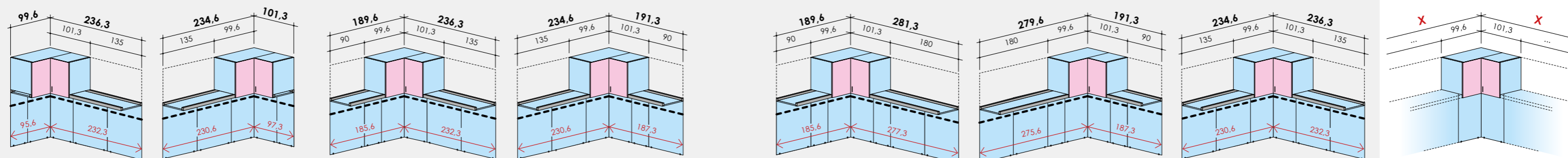

<b>Code</b>	PK39.41K	PK39.42R	PK39.43X	PK39.44D	PK39.45L	PK39.46S	PK39.47Y	PK39.40C *
ONE	matte							
	glossy							
CLUB								

## Ht 257.6

Over-bar wardrobe  
 Ht 128  
 Niche  
 Ht 129.6

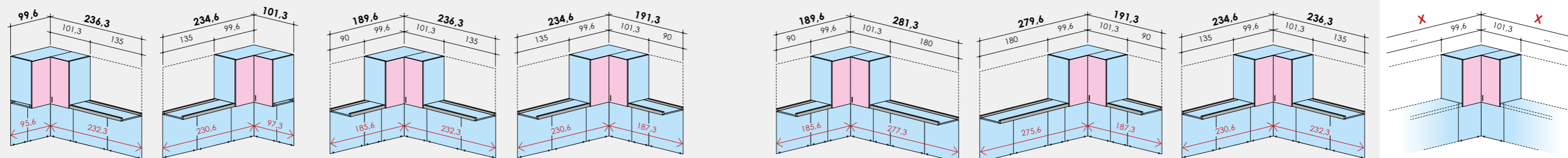

<b>Code</b>	PK39.51Q	PK39.52W	PK39.53C	PK39.54K	PK39.55R	PK39.56X	PK39.57D	PK39.50H *
ONE	matte							
	glossy							
CLUB								

**Movable shelf**  
 Dpt 51,5  
 Th 2,5

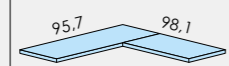

**BASIC clothes hanging bars**



**PLUS clothes hanging bars**

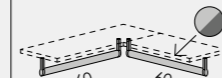

**Metal clothes reacher stick**

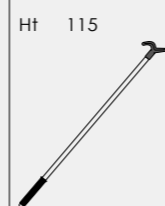

<b>Code</b>	PK01.41Q	P50.78Z	PK01.51V	PL04.17C				

Components in **GROUP 2 colors**  
 Components in **Types and colors FRONT**  
 AL1A GZ8T  
 - - Position of shelf, if installed

\* Price of the element in the GROUP 2 colors (CARCASE colors excluded)

Compositions must be completed with over-bar wardrobes (except for the corner unit, which is already included in the code).



**OPTIONAL: p. 268**  
 A · Extra colors for Top panel, Bottom panel and Shelves  
 B · Extra colors for Side panels  
 C · Increased back panel Th 0.8  
 D · PLUS clothes rail

Metal supporting bars available in the colors:  
 Bianco opaco (B17A)  
 Alluminio (AL1A)

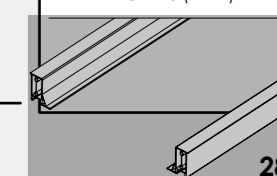

p. 56 Knob and handle positions

# Over-bar wardrobe for RIALTO bridge unit Dpt 56.3

		Ht 96		Ht 112		Ht 128								
<b>W 30</b> Specify hinge R or L	Reference images →													
	<b>Code</b>	<b>PK38.81B</b>	-	<b>PK37.60E</b>	-	<b>PK38.82H</b>	-							
	ONE	matte												
		glossy												
	CLUB													
<b>W 45</b> Specify hinge R or L	<b>Code</b>	<b>PK38.83Q</b>	-	<b>PK37.61M</b>	-	<b>PK38.84W</b>								
	ONE	matte												
		glossy												
	CLUB													
<b>W 60</b> Specify hinge R or L	<b>Code</b>	<b>PK38.85C</b>	<b>PK38.86K</b>	<b>PK37.62T</b>	<b>PK37.63Z</b>	<b>PK38.87R</b>	<b>PK38.88X</b>							
	ONE	matte												
		glossy												
	CLUB													
<b>W 90</b>	Reference images →													
	<b>Code</b>	<b>PK38.89D</b>	<b>PK38.90A</b>	<b>PK37.64F</b>	<b>PK37.65N</b>	<b>PK38.91G</b>	<b>PK38.92P</b>							
	ONE	matte												
		glossy												
	CLUB													
<b>Corner over-bar wardrobe</b>														
	<b>Code</b>	<b>PK39.31D</b>	<b>PK39.48E</b>		<b>PK39.32L</b>									
	ONE	matte												
		glossy												
	CLUB													

- Components in **GROUP 2 colors**
- Components in **Types and colors FRONT**
- Element fitted with clothes hanging bar.
- The element cannot be turned upside down.
- With doors **W 30**
- With doors **W 30 + W 60** - Indicate R or L (drawing - R)

• It is essential to send a drawing of the complete overhead structure to allow us to prepare the elements correctly.

**OPTIONAL:** p. 268

- A** · Extra colors for Top panel, Bottom panel and Shelves
- B** · Extra colors for Side panels
- C** · Increased back panel Th 0.8
- D** · PLUS clothes rail

p. 56 Knob and handle positions  
p. 277 Accessories for RIALTO bridge unit Dpt 56.3

# Elements for RIALTO bridge unit Dpt 56.3

## Side support panels Dpt 57.1 - Th 2.5

With adjustable middle-support feet  
Specify L or R  
(L drawings)

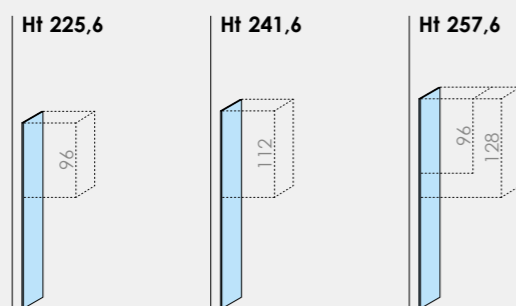

Code	PK39.07B	PK37.70L	PK39.08H						
------	----------	----------	----------	--	--	--	--	--	--

## Side support panels with metal structure and filler side panel Dpt 57.1 - Th 2.5

With adjustable feet

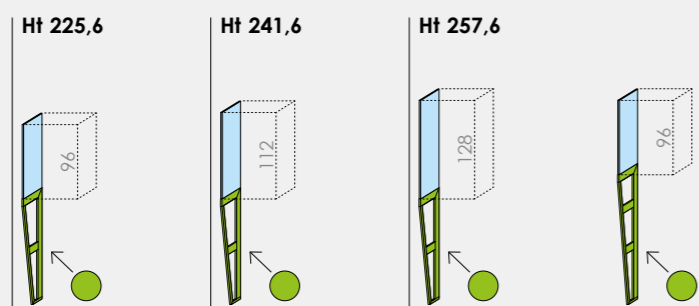

The SG200 and SG201 peninsulas with shaped top can be fixed to the side support panel.  
A special bracket will be supplied for this purpose during order fulfilment (Code P08.39C).



Code	PK39.09Q	PK37.71S	PK39.10M	PK39.11T					
------	----------	----------	----------	----------	--	--	--	--	--

## Side support panels with to C metal structure and filler side panel Dpt 57.1 - Th 2.5

With adjustable feet

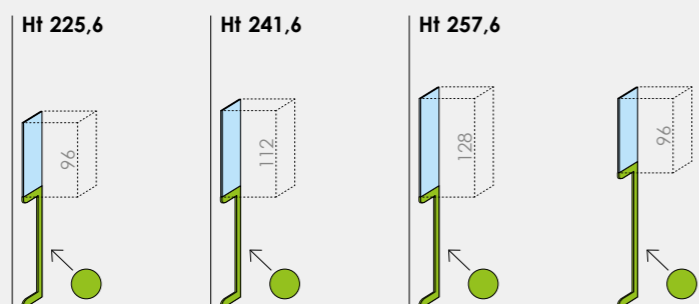

Code	PK37.83L	PK37.84S	PK37.85Y	PK37.86E					
------	----------	----------	----------	----------	--	--	--	--	--

## SMART support bookshelf Dpt 57.1 - W 33.3

With adjustable middle-support feet  
In end elements specify L or R (L in the drawing)

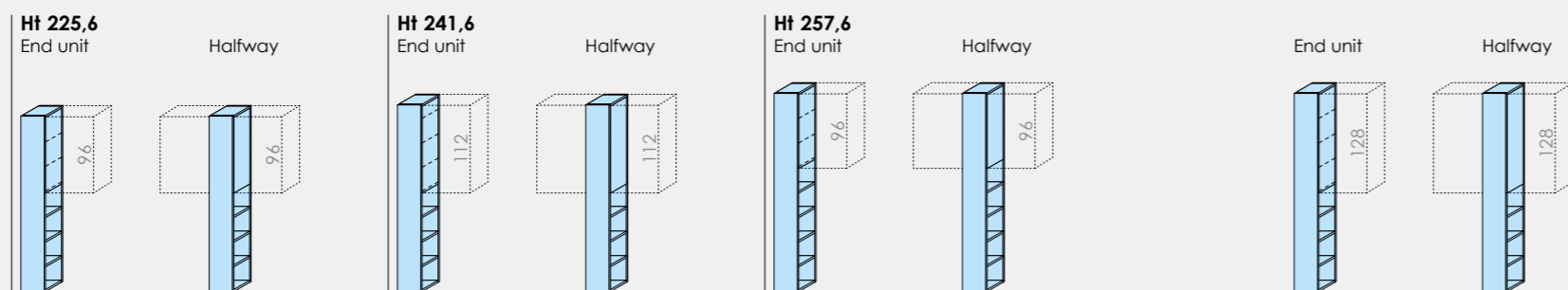

Code	PK39.20S	PK39.21Y	PK37.75T	PK37.76Z	PK39.22E	PK39.23M	PK39.24T	PK39.25Z	
------	----------	----------	----------	----------	----------	----------	----------	----------	--

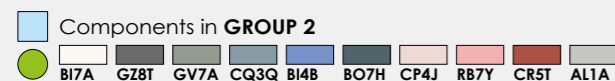

## Optional back panels

### Th 1.8

With adjustable middle-support feet

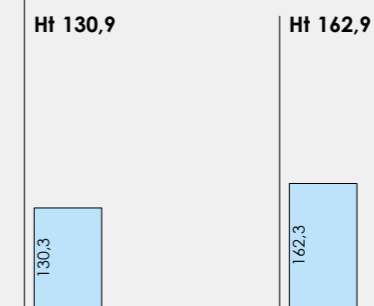

W	Code	Code
45	PK39.01N	PK39.02U
60	PK39.03A	PK39.04G
90	PK39.05P	PK39.06V

### Cutting of back panels to custom sizes.

The upper measure panel is used by applying the surcharge.

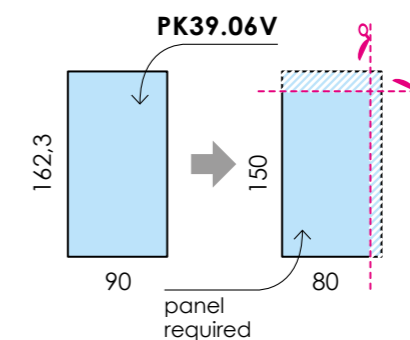

Example:  
If you want a panel L 80 x H 150, use the panel Code **PK39.06V** and make 2 cuts; therefore the cost of the panel will be:  
135,00 (35,00 x 2 = 70,00 + 65,00).

## Metal supporting bars

### Ht 6 - Dpt 53

Including panel of compartment open for inspection



W	Code
90	PK39.60P
105	PK39.61V
120	PK39.62B
135	PK39.63H
180	PK39.64Q
210	PK39.65W
225	PK39.66C
Custom-made Max 270 Min 30	PK39.67K

Metal supporting bars available in the colors:  
Bianco opaco (B17A)  
Alluminio (AL1A)

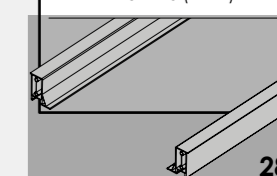

• It is essential to send a drawing of the complete overhead structure to allow us to prepare the elements correctly.

GROUP 1 colors	Rovere Dorian RD5T	Rovere white RW3Q	Noce naturale NN7H	Eucalipto CL1X	Domy DM7P	Bianco UV BU3Q
	Ciliegio bianco CB6K	Malta ML7H	Feltro FL8X	Cemento Masdar CM3Q	Blu indaco BI4B	
	Noce NC4B	Desert DS9L	Canapa CN1X	Moka MK6B	Cipria CP4J	
	Bianco opaco BI7A	Grigio Dorian GL4R	Basalto BS5T	Grigio titanio GZ8T	Rosa bubble RB7Y	
GROUP 2 colors	Agave GV7A	Verde Alpi VA5T	Cadaques CQ3Q	Giallo zafferano GZ8A		
	Blu opale BO7H			Corallo CR5T		
GROUP 3 colors						
CARCASE colors						

Types and colors FRONT	ONE	Rovere white RW3Q	Rovere Dorian RD5T	Ciliegio bianco CB6K	Noce naturale NN7H	Noce NC4B	Eucalipto CL1X	Malta ML7H	
		Feltro FL8X	Cemento Masdar CM3Q	Bianco opaco BI7A	Desert DS9L	Canapa CN1X	Moka MK6B	Grigio Dorian GL4R	
		Basalto BS5T	Grigio titanio GZ8T	Domy DM7P	Agave GV7A	Verde Alpi VA5T	Cadaques CQ3Q	Blu indaco BI4B	
		Blu opale BO7H	Cipria CP4J	Rosa bubble RB7Y	Giallo zafferano GZ8A	Corallo CR5T			
CLUB	CLUB	Rovere white RW3Q	Rovere Dorian RD5T	Ciliegio bianco CB6K	Noce naturale NN7H	Noce NC4B	Eucalipto CL1X	Malta ML7H	
		Feltro FL8X	Cemento Masdar CM3Q	Bianco opaco BI7A	Desert DS9L	Canapa CN1X	Moka MK6B	Grigio Dorian GL4R	
		Basalto BS5T	Grigio titanio GZ8T	Domy DM7P	Agave GV7A	Verde Alpi VA5T	Cadaques CQ3Q	Blu indaco BI4B	
		Blu opale BO7H	Cipria CP4J	Rosa bubble RB7Y	Giallo zafferano GZ8A	Corallo CR5T			
Specify the color of the CLUB handle									
	Bianco opaco BI7A	Desert DS9L	Canapa CN1X	Moka MK6B	Grigio Dorian GL4R	Basalto BS5T	Grigio titanio GZ8T		
	Domy DM7P	Agave GV7A	Verde Alpi VA5T	Cadaques CQ3Q	Blu indaco BI4B	Blu opale BO7H	Cipria CP4J		
	Rosa bubble RB7Y	Giallo zafferano GZ8A	Corallo CR5T						
WINDOW	WINDOW	Trasparente TR9M	Trasparente fumé FT8P	Stop-sol ST6P	Specchio SP7L				
		Specify the color of the aluminum frame							
		Alluminio AL1A	Titan grey TG7H						

Loft beds - Bunk beds

Loft beds - technical information	288
OPTIONAL for Loft beds	290
KINTAI loft beds Dpt 93.3	292
IRON loft beds Ht 225.6	296
IRON loft beds Ht 241.6	298
IRON loft beds Ht 257.6	300
CREEK loft beds	302
HELIX loft beds	304
Side support panels for Loft beds	306
Accessories for Loft beds	307
FORMENTERA bunk bed Ht 184.6 - W 200 - Dpt 88.3	308
SPRINT bunk beds	310
SLOT bunk beds bed base W 80	312
SLOT bunk beds bed base W 90	313
OSLO bunk beds	314
Metal ladders and guards for Loft beds and Bunk beds	315
MARGOT container ladder with shaped sides	316
GRETA container ladder with shaped sides with PLATFORM	317
CLIVIA container ladder with shaped sides	320
DALIA container ladder with shaped sides	321
HAPPY equipped bunk bed, bed base W 90	322
HAPPY equipped bunk bed, bed base W 90 L-SHAPED	324
HAPPY equipped bunk bed, bed base W 90 WITH WALK-IN WARDROBE	325
HAPPY single beds, bed base W 90	326
Accessories for HAPPY	327



# Loft beds - technical information

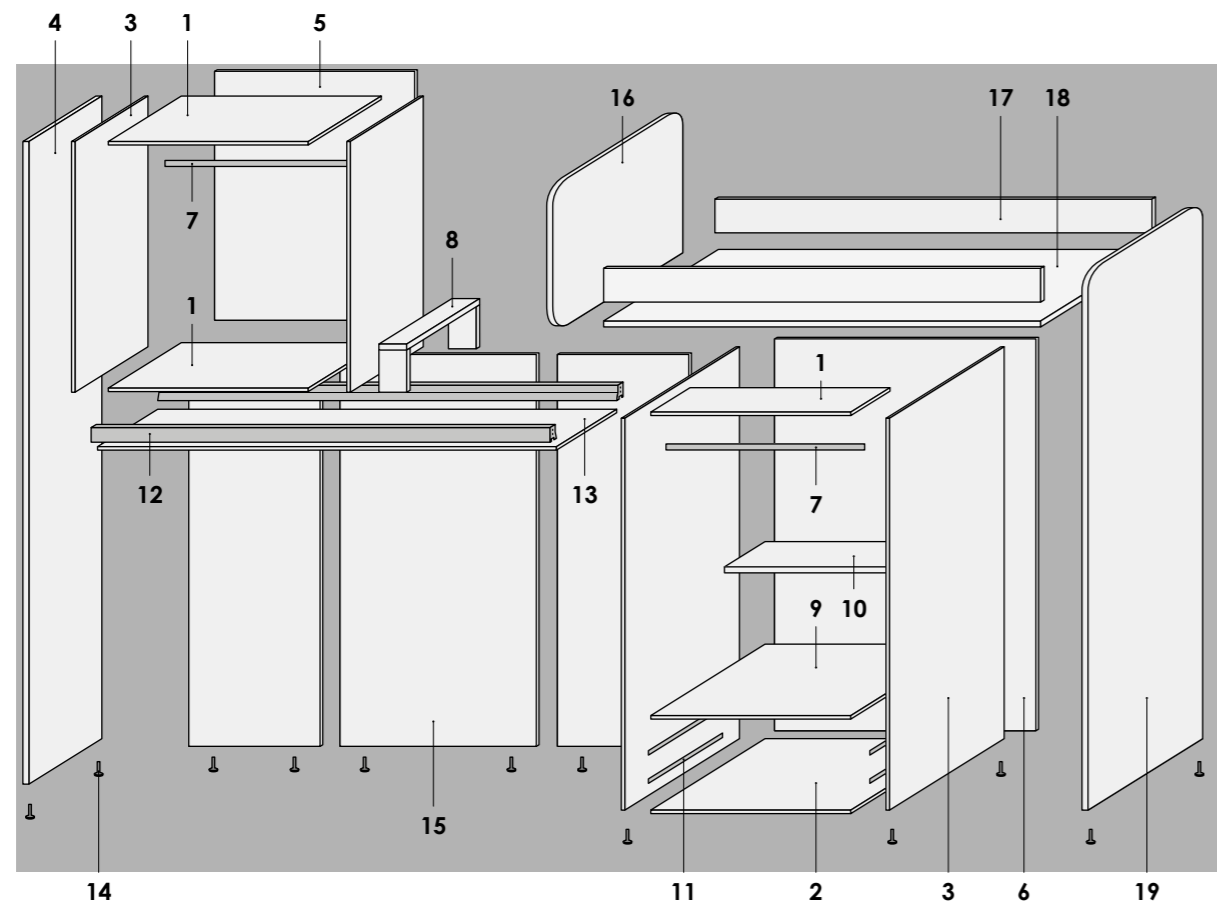

## Components:

- 1 Top panel Th 1.8 - With eccentric pin system
- 2 Bottom panel Th 1.8 - With eccentric pin system
- 3 Side panels Th 1.8 - With prefitted hardware.
- 4 Side support panels Th 2.5
- 5 Back panel Th 0.3 or 0.8 (optional) - Fitting into shaped connection.
- 6 Wardrobe back panel Dpt 88.5, Th 1.8
- 7 BASIC clothes hanging bar in chromed metal  
PLUS clothes hanging bar (optional) in aluminum.
- 8 Magazine holder
- 9 Dividing movable shelf Th 2.5 Dpt 53 - With sliding support.
- 10 Movable shelf Th 2.5 Dpt 28.6 (optional) - With sliding support.
- 11 Metal drawer runners
- 12 Metal bars
- 13 Panel compartment for inspection
- 14 Adjustable middle-support feet
- 15 Back panels
- 16 Shaped panel Sp 2.5 for platform bed headboard
- 17 Platform bed side panels
- 18 Platform bed base (vault)
- 19 Shaped side Th 2.5 for platform bed

## IMPORTANT!

- All Loft beds are fitted with adjustable feet.
- The doors are fitted with decelerated hinges.
- The drawers and big drawer CLUB are always fitted with height-adjustable soft-close "Quadro" metal slides with interior CHARM finish.
- **Internal fittings supplied consist in: Wardrobes Dpt 87.7 and Bridge units Dpt 56.3** are equipped with 1 clothes hanging bar.
- **For custom cuts consult the relevant chapter.**
- Upon request, the doors can be supplied without a handle and without handle holes (Not CLUB doors).
- Loft beds are retrofitted; the KINTAI loft bed can also be placed in the center of the room.
- **For the overturning bed use only the mattresses W 75.**
- Platform beds with overturning base cannot be used in IRON, CREEK and HELIX loft beds.
- **When ordering have to be added: a platform bed, the metal ladder, the ladders with shaped sides, 1 or more guards.**
- Panel compartment for inspection in carcass colours.

## Loft beds examples

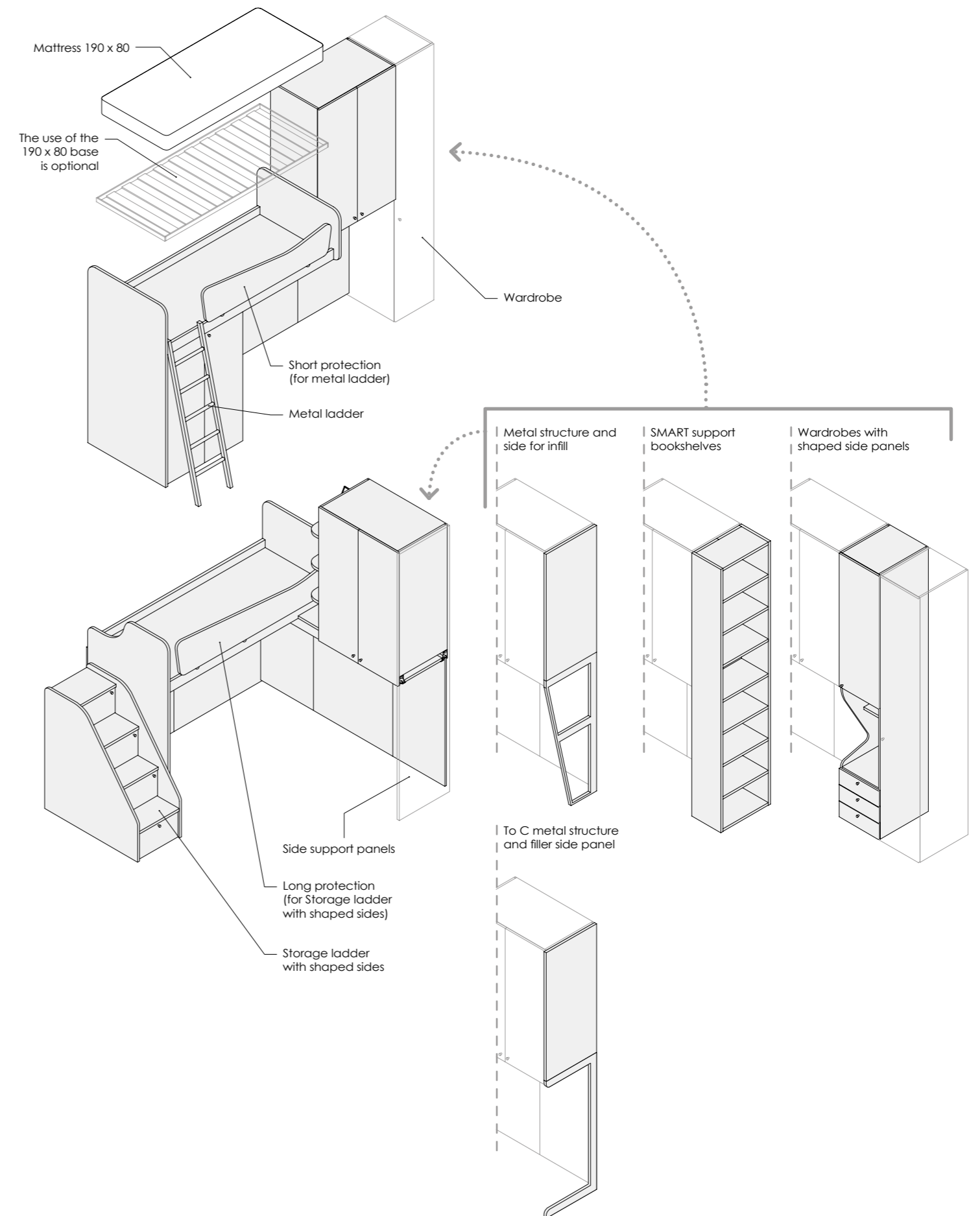

## OPTIONAL for Loft beds

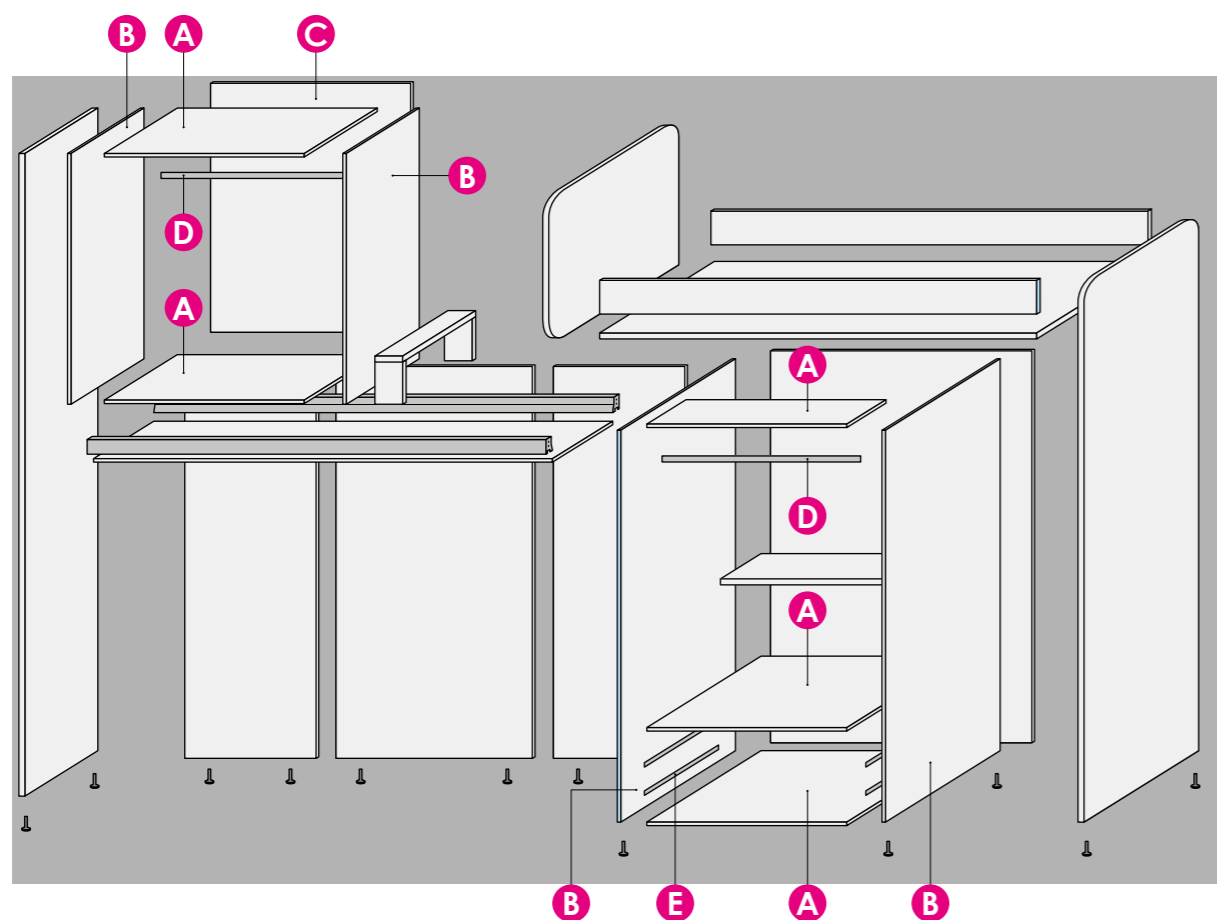

### A Extra colors for Top panel, Bottom panel and Shelves

In addition to the standard CARCASE colors, these components are all available in the GROUP 2 colors *with surcharge* (see table).

- **When placing the order:** indicate the colour in the HORIZONTAL FINISHES variant in Metron 4: all top panels, bottom panels and shelves will automatically be delivered in that colour (if specified, the various elements can be coloured as preferred).
- **N.B.** The surcharge is applied to each single component.

Top panel Bottom panel (bridge unit Dpt 56.3)	Surcharge for single element (CARCASE colors excluded)
W 45	
W 90	
Top panel Bottom panel Shelves (wardrobe Dpt 87.7)	Surcharge for single element (CARCASE colors excluded)
W 45	
W 90	

### B Extra colors for Side panels

In addition to the standard CARCASE colors, the side panels are available in all the GROUP 2 colors *with surcharge* (see table).

- **When placing the order:** indicate the colour in the COLOURED FINISHES variant in Metron 4: all side panels will automatically be delivered in that colour (if specified, 1, 2 or more side panels can be coloured as preferred).
- **N.B.** The surcharge is applied to each single side panel.

Side panel (bridge unit Dpt 56.3)	Surcharge for single element (CARCASE colors excluded)
Ht 96	
Ht 112	
Ht 128	
Side panel (wardrobe Dpt 87.7)	Surcharge for single element (CARCASE colors excluded)
Ht 136	

### C Increased Back panel Th 0.8

On request the overhead Wardrobe can be equipped with a back panel Th 0.8 *with surcharge* (see table), in replacement of the standard back panel Th 0.3; unlike the standard one (in the CARCASE colors), the increased back panel is available in all GROUP 2 colors.

- **When placing the order:** indicate YES for increased back panel in the BACK PANEL TYPE variant and the colour in the BACK PANEL COLOUR variant in Metron 4: all back panels will automatically be supplied in the same type and colour (if specified, it is possible to change the back panel type and colour of the various elements as preferred).
- **N.B.** The surcharge is applied to each back panel.

Back panel Th 0.8 (bridge unit Dpt 56.3)	Surcharge for single element
	Ht 96 - 112 - 128
W 45	
W 90	

### D PLUS clothes-hanging bar

On request the wardrobe can be equipped with PLUS clothes-hanging bars *with surcharge* (see table). The PLUS clothes-hanging bar is in aluminium Ø 2.8, available in the Alluminio (AL1A) and Grigio titanio (GZ8T) colors.

- **When placing the order:** indicate PLUS clothes-hanging bar in the BAR TYPE variant and the colour in the BAR COLOUR variant in Metron 4: all bars will automatically be delivered in the same type and same colour.



Clothes-hanging bar	Surcharge for single element
W 45	
W 90	

### E Drawers and big drawers with soft-close

On request drawers and big drawers in the "standard" version can be equipped with soft-close mechanisms, *with surcharge* (see table). Alternatively, drawers and big drawers can be ordered in the CHARM version, *with surcharge* (see table), equipped with height-adjustable "Quadro" type runners with prestigious internal finish.

- **When placing the order:** indicate the type of runners in the RUNNER TYPE variant in Metron 4.
- **N.B.** the CLUB drawers and big drawers are standard in the CHARM version with soft-close "Quadro" type runners (without surcharge).

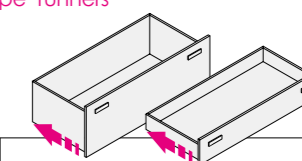

Slow closing	Surcharge for single element
Drawers W 45 - 90	
Big drawer W 45 - 90	
CHARM Drawers/Big drawers with "Quadro" slides W 45 - 90	



# KINTAI loft beds Dpt 93.3

Compositions must be completed with wardrobes/wardrobes with shaped side panels (Dpt 56.3) or the side support panels/bookshelves (Dpt 57.1) Ht 225.6 or 241.6.

When ordering, a platform bed, the metal ladder or the ladders with shaped sides have to be added.

The width dimensions include the floor-standing side panel of the platform bed (Th 2.5).

## Ht 225,6

Specify R or L (L in drawing)

w 257,5

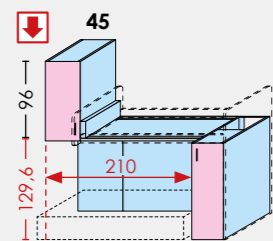

w 257,5

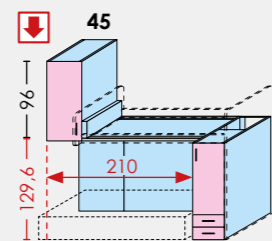

w 257,5

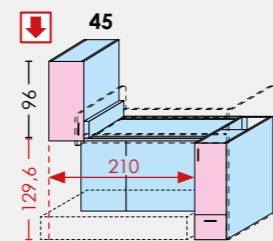

w 302,5

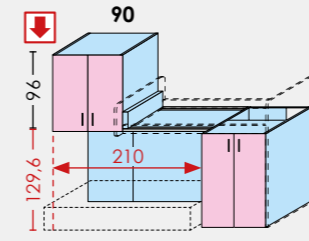

w 302,5

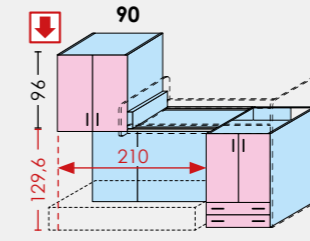

w 302,5

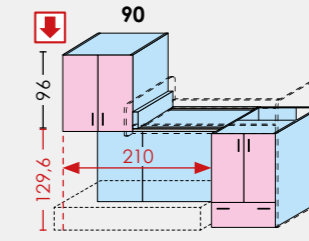

Code	PK40.01B	PK40.02H	PK40.03Q	PK40.04W	PK40.05C	PK40.06K
ONE	matte					
	glossy					
CLUB						

## Ht 241,6

Specify R or L (L in drawing)

w 257,5

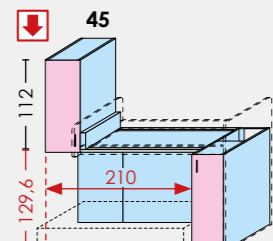

w 257,5

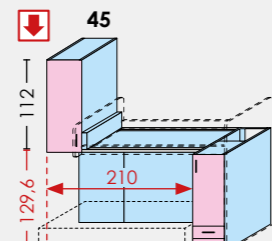

w 257,5

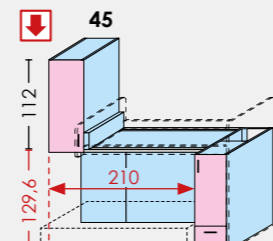

w 302,5

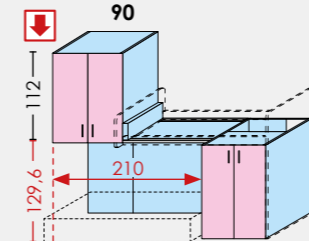

w 302,5

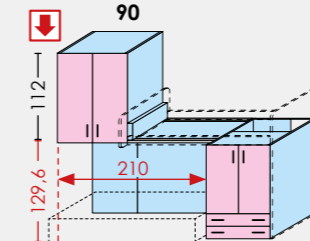

w 302,5

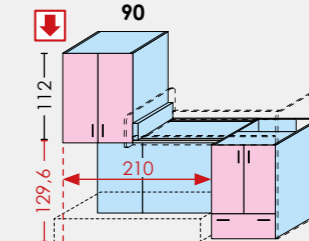

Code	PK41.10E	PK41.11M	PK41.12T	PK41.13Z	PK41.14F	PK41.15N
ONE	matte					
	glossy					
CLUB						

## Ht 184,6

### Dpt 93.3

Platform beds  
W 200

Bed internal dimensions 195 x 81.  
Can be used without base.  
**1 or more guards must be ordered.**  
Specify R or L (L in drawing)

Use the: mattress and bed base 190 x 80

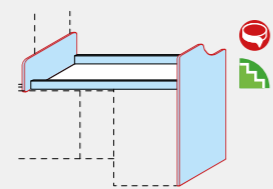
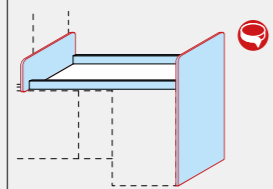

With fold-away slatted base.  
**1 or more guards must be ordered.**  
Specify R or L (L in drawing)

Use the: mattress 190 x 75

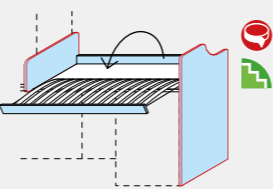
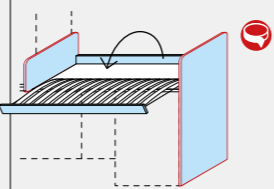

Fold-away  
base movement

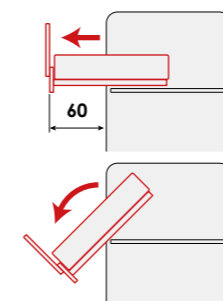

Code	PK40.13V	PK40.14B	PK40.13VRR	PK40.14BRR
------	----------	----------	------------	------------

- Components in **CARCASE** colors
- Components in **GROUP 2** colors
- Components in **Types and colors FRONT**

- Shaped components available with contrasting edging.
- The ladder with shaped sides may be used.



- OPTIONAL:** p. 290
- A · Extra colors for Top panel, Bottom panel and Shelves
  - B · Extra colors for Side panels
  - C · Increased Back panel Th 0.8
  - D · PLUS clothes-hanging bar
  - E · Drawers and big drawers with soft-close



- p. 56 Knob and handle positions
- p. 306 Side support panels for Loft beds
- p. 307 Accessories for Loft beds
- p. 315 Metal ladders and guards for Loft beds and Bunk beds

Mattresses, pillows and slatted bed base  
See back cover wing



**CLUB**  
drawers and big drawers  
CHARM with soft-close "Quadro"  
type slides as standard  
(without surcharges)

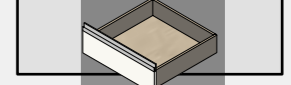

Metal supporting bars  
available in the colors:  
Bianco opaco (BIZA)  
Alluminio (ALTA)



# KINTAI loft beds Dpt 93.3

Compositions must be completed with wardrobes/wardrobes with shaped side panels (Dpt 56.3) or the side support panels/bookshelves (Dpt 57.1) Ht 257.6.

When ordering, a platform bed, the metal ladder or the ladders with shaped sides have to be added.

The width dimensions include the floor-standing side panel of the platform bed (Th 2.5).

## Ht 257,6

Specify R or L (L in drawing)

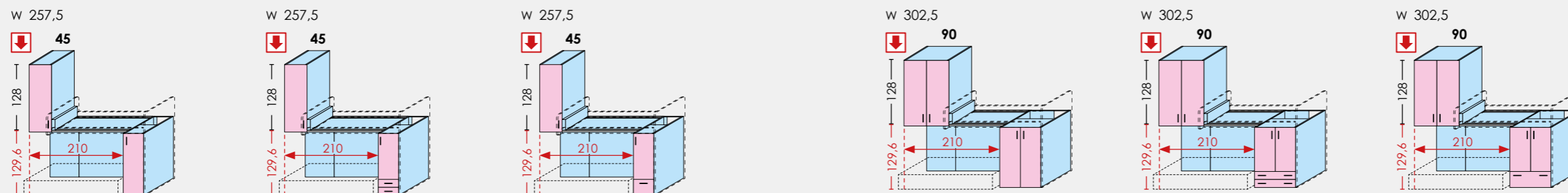

Code	PK40.07R	PK40.08X	PK40.09D	PK40.10A	PK40.11G	PK40.12P
ONE	matte					
	glossy					
CLUB						

## Ht 184.6 Dpt 93.3 Platform beds W 200

Bed internal dimensions 195 x 81.  
Can be used without base.  
1 or more guards must be ordered.  
Specify R or L (L in drawing)

Use the: mattress and bed base 190 x 80

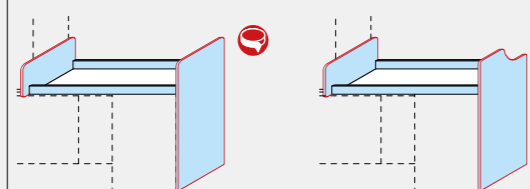

With fold-away slatted base.  
1 or more guards must be ordered.  
Specify R or L (L in drawing)

Use the: mattress 190 x 75

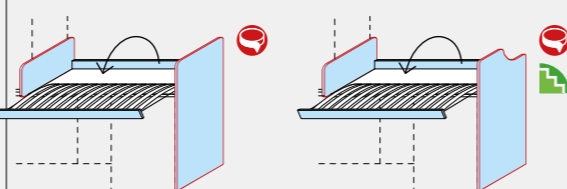

Fold-away base movement

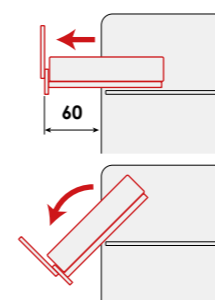

Code	PK40.13V	PK40.14B	PK40.13VRR	PK40.14BRR
------	----------	----------	------------	------------

- Components in **CARCASE** colors
- Components in **GROUP 2** colors
- Components in **Types and colors FRONT**

- Shaped components available with contrasting edging.
- The ladder with shaped sides may be used.



- OPTIONAL:** p. 290
- A · Extra colors for Top panel, Bottom panel and Shelves
  - B · Extra colors for Side panels
  - C · Increased Back panel Th 0.8
  - D · PLUS clothes-hanging bar
  - E · Drawers and big drawers with soft-close



- p. 56 Knob and handle positions
- p. 306 Side support panels for Loft beds
- p. 307 Accessories for Loft beds
- p. 315 Metal ladders and guards for Loft beds and Bunk beds

Mattresses, pillows and slatted bed base  
See back cover wing



**CLUB**  
drawers and big drawers  
CHARM with soft-close "Quadro"  
type slides as standard  
(without surcharges)

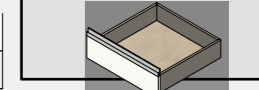

Metal supporting bars  
available in the colors:  
Bianco opaco (B17A)  
Alluminio (AL1A)



# IRON loft beds Ht 225.6

Compositions must be completed with wardrobes/wardrobes with shaped side panels (Dpt 56.3) or the side support panels/bookshelves (Dpt 57.1) Ht 225.6.

When ordering, a platform bed, the metal ladder or the ladders with shaped sides have to be added.  
The external dimensions on the bed side include the floor-standing side panel of the platform bed (Th 2.5).

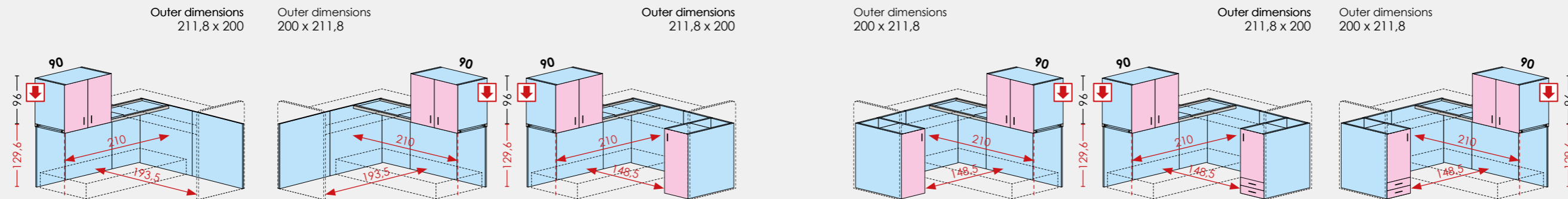

Code	PK40.15H	PK40.16Q	PK40.17W	PK40.18C	PK40.19K	PK40.20F
ONE	matte					
	glossy					
CLUB						

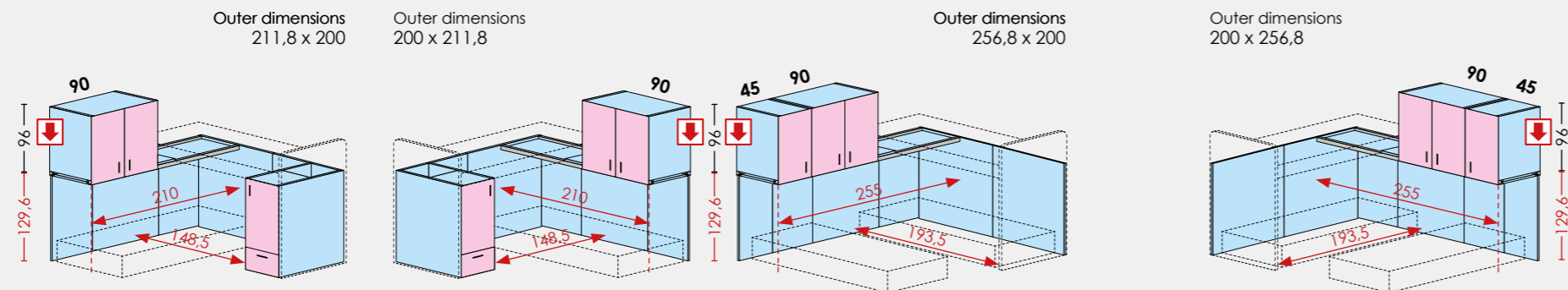

Code	PK40.21N	PK40.22U	PK40.23A	PK40.24G
ONE	matte			
	glossy			
CLUB				

## Ht 184.6 Dpt 88.3 Platform beds W 200

Bed internal dimensions 195 x 81. Can be used without base.  
**1 or more guards must be ordered.**

Use the: mattress and bed base 190 x 80

BASE

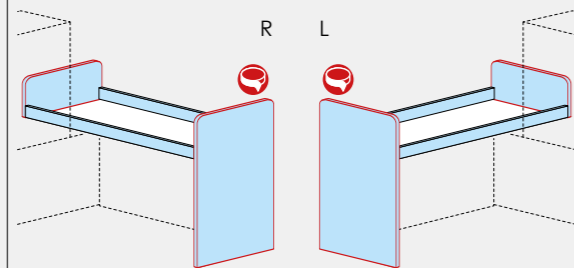

DUNA

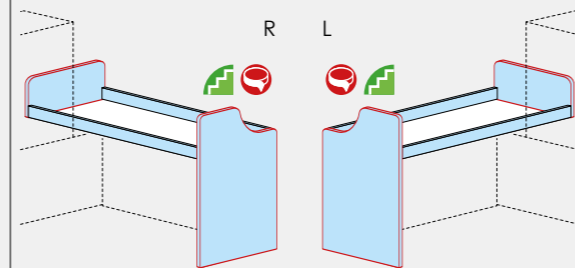

ARCO

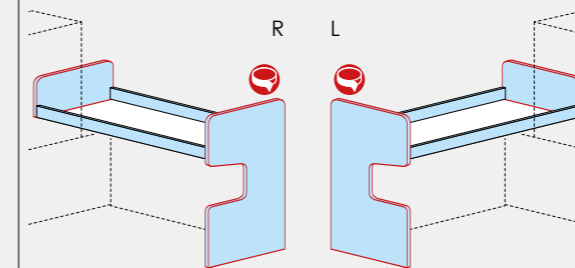

Code	PK40.25P	PK40.26V	PK40.27B	PK40.28H	PK40.29Q	PK40.30M

- Components in **CARCASE** colors
- Components in **GROUP 2** colors
- Components in **Types and colors FRONT**

- Shaped components available with contrasting edging.
- The ladder with shaped sides may be used.



- OPTIONAL:** p. 290
- A · Extra colors for Top panel, Bottom panel and Shelves
  - B · Extra colors for Side panels
  - C · Increased Back panel Th 0.8
  - D · PLUS clothes-hanging bar
  - E · Drawers and big drawers with soft-close



- p. 56 Knob and handle positions
- p. 306 Side support panels for Loft beds
- p. 307 Accessories for Loft beds
- p. 315 Metal ladders and guards for Loft beds and Bunk beds

Mattresses, pillows and slatted bed base  
See back cover wing



**CLUB**  
drawers and big drawers  
CHARM with soft-close "Quadro"  
type slides as standard  
(without surcharges)

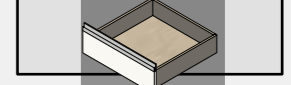

Metal supporting bars  
available in the colors:  
Bianco opaco (BIZA)  
Alluminio (ALTA)





# IRON loft beds Ht 241.6

Compositions must be completed with wardrobes/wardrobes with shaped side panels (Dpt 56.3) or the side support panels/bookshelves (Dpt 57.1) Ht 241.6.

When ordering, a platform bed, the metal ladder or the ladders with shaped sides have to be added.  
The external dimensions on the bed side include the floor-standing side panel of the platform bed (Th 2.5).

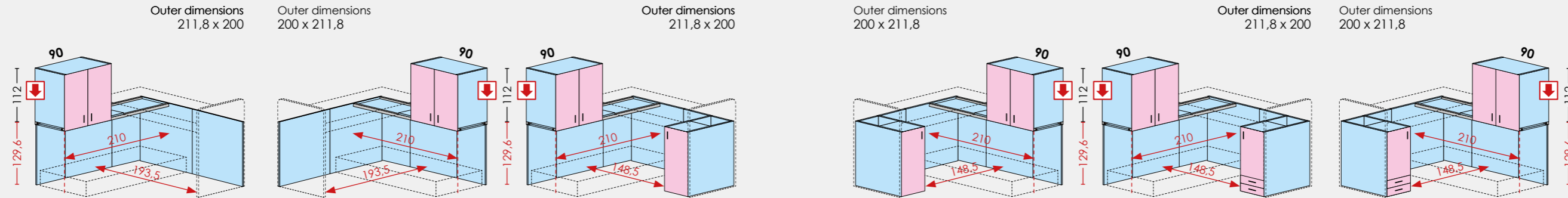

Code	PK41.16U	PK41.17A	PK41.18G	PK41.19P	PK41.20L	PK41.21S
ONE	matte					
	glossy					
CLUB						

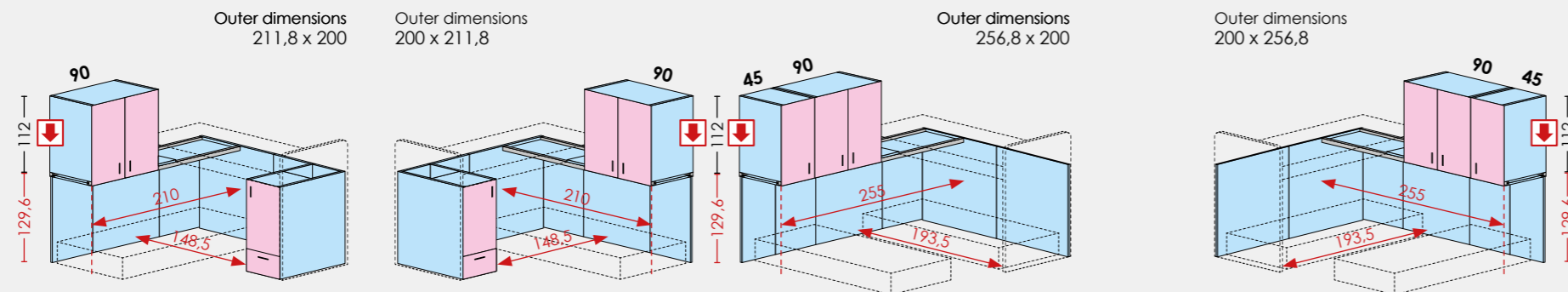

Code	PK41.22Y	PK41.23E	PK41.24M	PK41.25T
ONE	matte			
	glossy			
CLUB				

## Ht 184.6 Dpt 88.3 Platform beds W 200

Bed internal dimensions 195 x 81. Can be used without base.  
**1 or more guards must be ordered.**

Use the: mattress and bed base 190 x 80

BASE

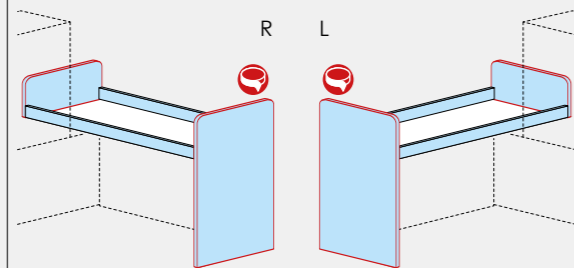

DUNA

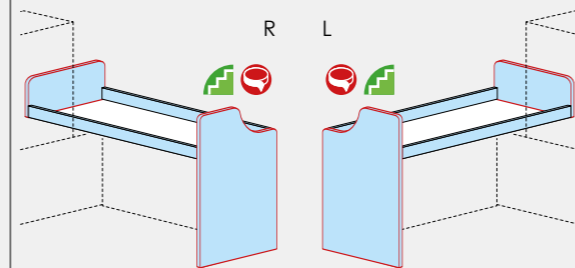

ARCO

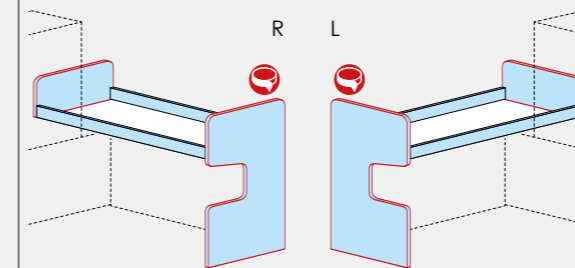

Code	PK40.25P	PK40.26V	PK40.27B	PK40.28H	PK40.29Q	PK40.30M

- Components in **CARCASE** colors
- Components in **GROUP 2** colors
- Components in **Types and colors FRONT**

- Shaped components available with contrasting edging.
- The ladder with shaped sides may be used.



- OPTIONAL:** p. 290
- A · Extra colors for Top panel, Bottom panel and Shelves
  - B · Extra colors for Side panels
  - C · Increased Back panel Th 0.8
  - D · PLUS clothes-hanging bar
  - E · Drawers and big drawers with soft-close



- p. 56 Knob and handle positions
- p. 306 Side support panels for Loft beds
- p. 307 Accessories for Loft beds
- p. 315 Metal ladders and guards for Loft beds and Bunk beds

Mattresses, pillows and slatted bed base  
See back cover wing



**CLUB**  
drawers and big drawers  
CHARM with soft-close "Quadro"  
type slides as standard  
(without surcharges)

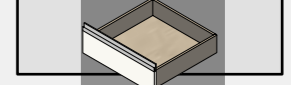

Metal supporting bars  
available in the colors:  
Bianco opaco (BIZA)  
Alluminio (ALTA)





# IRON loft beds Ht 257.6

Compositions must be completed with wardrobes/wardrobes with shaped side panels (Dpt 56.3) or the side support panels/bookshelves (Dpt 57.1) Ht 257.6.

When ordering, a platform bed, the metal ladder or the ladders with shaped sides have to be added.

The external dimensions on the bed side include the floor-standing side panel of the platform bed (Th 2.5).

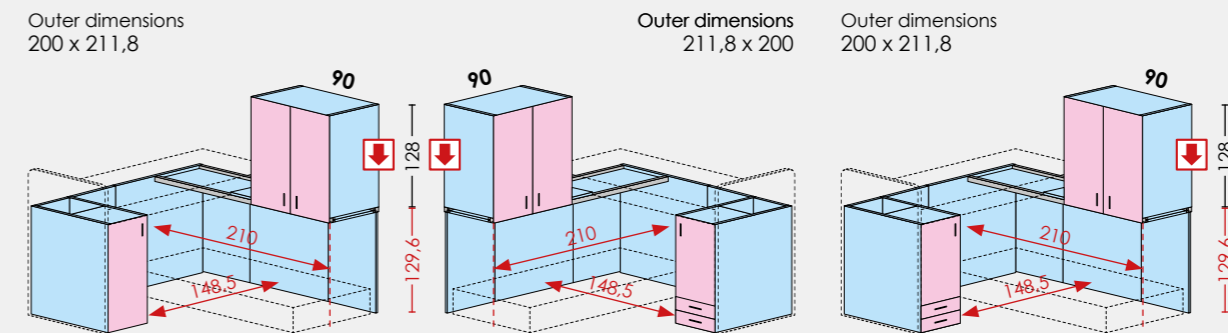
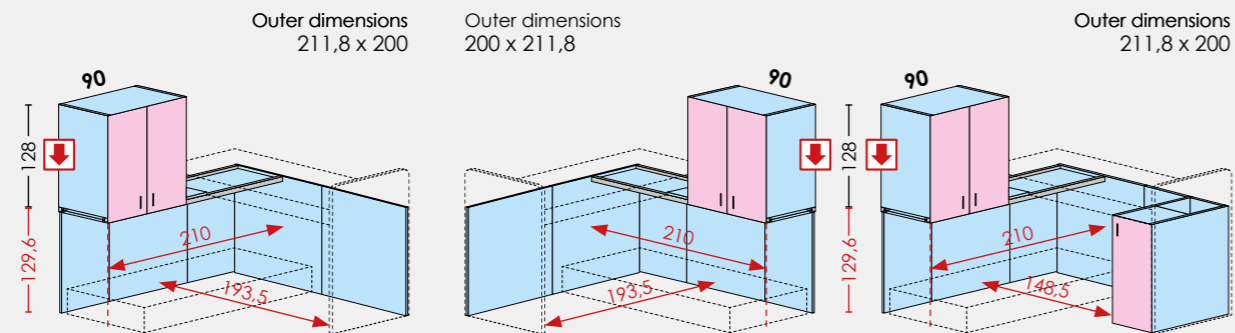

Code	PK40.31T	PK40.32Z	PK40.33F	PK40.34N	PK40.35U	PK40.36A
ONE	matte					
	glossy					
CLUB						

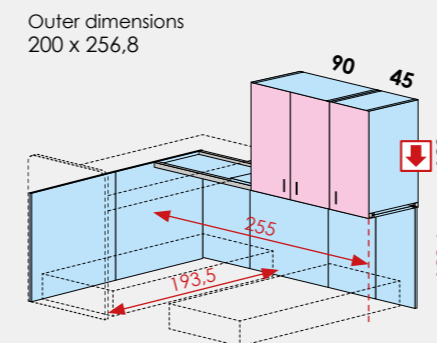
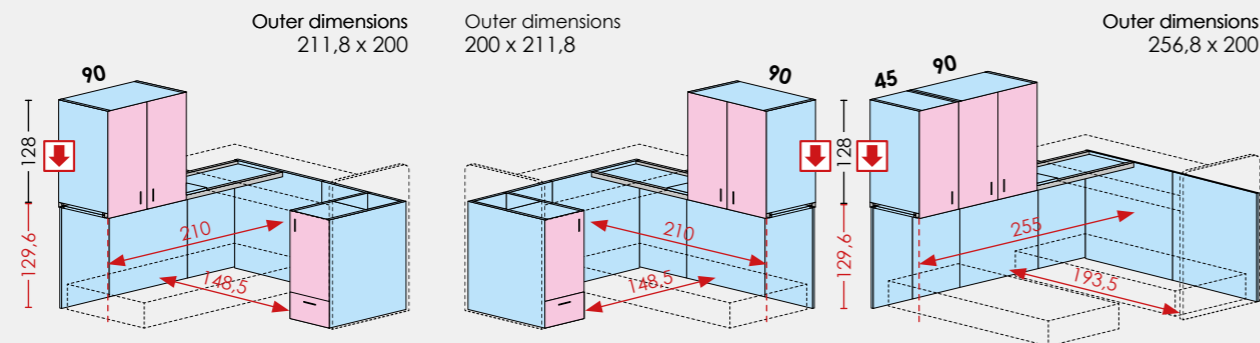

Code	PK40.37G	PK40.38P	PK40.39V	PK40.40S
ONE	matte			
	glossy			
CLUB				

## Ht 184.6 Dpt 88.3 Platform beds W 200

Bed internal dimensions 195 x 81. Can be used without base.

1 or more guards must be ordered.

Use the: mattress and bed base 190 x 80

BASE

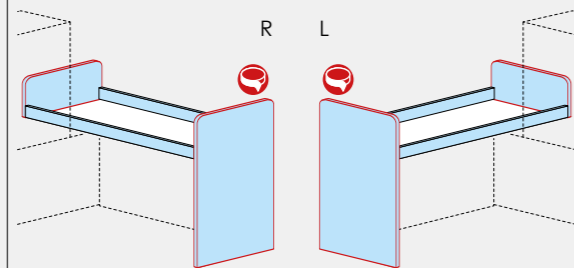

DUNA

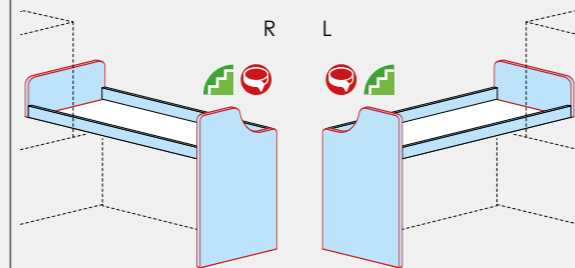

ARCO

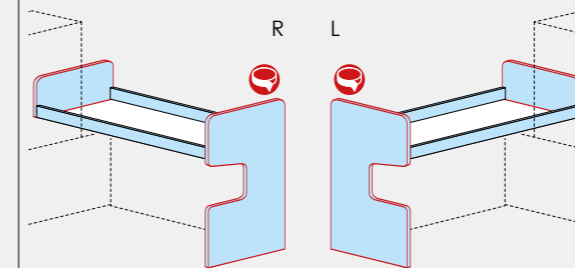

Code	PK40.25P	PK40.26V	PK40.27B	PK40.28H	PK40.29Q	PK40.30M
------	----------	----------	----------	----------	----------	----------

- Components in **CARCASE** colors
- Components in **GROUP 2** colors
- Components in **Types and colors FRONT**

- Shaped components available with contrasting edging.
- The ladder with shaped sides may be used.



- OPTIONAL:** p. 290
- A · Extra colors for Top panel, Bottom panel and Shelves
  - B · Extra colors for Side panels
  - C · Increased Back panel Th 0.8
  - D · PLUS clothes-hanging bar
  - E · Drawers and big drawers with soft-close



- p. 56 Knob and handle positions
- p. 306 Side support panels for Loft beds
- p. 307 Accessories for Loft beds
- p. 315 Metal ladders and guards for Loft beds and Bunk beds

Mattresses, pillows and slatted bed base  
See back cover wing



**CLUB**  
drawers and big drawers  
CHARM with soft-close "Quadro"  
type slides as standard  
(without surcharges)

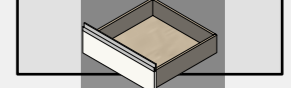

Metal supporting bars  
available in the colors:  
Bianco opaco (BIZA)  
Alluminio (ALTA)

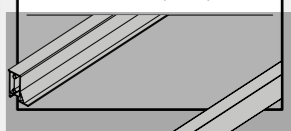

# CREEK loft beds

Compositions must be completed with wardrobes/wardrobes with shaped side panels (Dpt 56.3) or the side support panels/bookshelves (Dpt 57.1) Ht 225.6, 241.6 or 257.6.

When ordering, a platform bed and the metal ladder have to be added.

The external dimensions on the bed side include the floor-standing side panel of the platform bed (Dpt 26).

## Ht 225,6

Outer dimensions  
211,8 x 200

Outer dimensions  
200 x 211,8

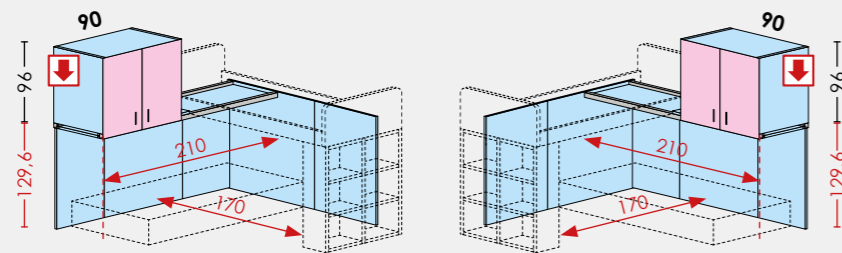

Code	PK40.41Y	PK40.42E	
ONE	matte		
	glossy		
CLUB			

## Ht 257,6

Outer dimensions  
211,8 x 200

Outer dimensions  
200 x 211,8

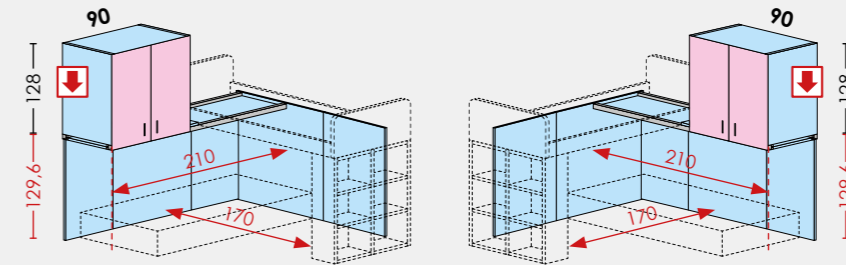

Code	PK40.43M	PK40.44T	
ONE	matte		
	glossy		
CLUB			

## Ht 241,6

Outer dimensions  
211,8 x 200

Outer dimensions  
200 x 211,8

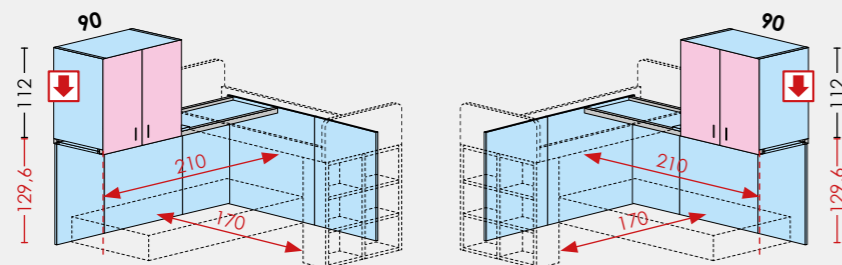

Code	PK41.26Z	PK41.27F	
ONE	matte		
	glossy		
CLUB			

## Ht 184.6

### Dpt 88.3

Platform beds  
W 200

Bed internal dimensions 195 x 81. Can be used without base.

1 or more guards must be ordered.

Use the: mattress and bed base 190 x 80

AREE

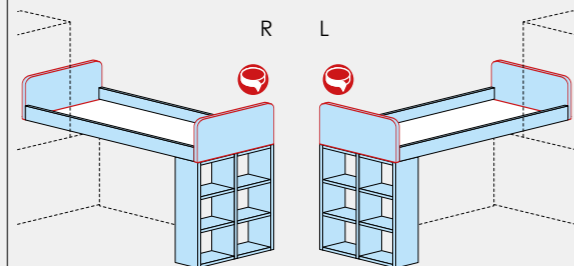

LOVE

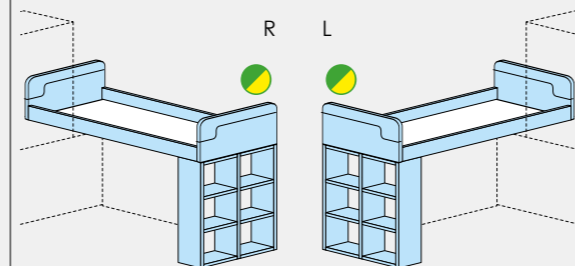

Code	PK40.45Z	PK40.46F	PK40.47N	PK40.48U				

Components in **CARCASE** colors  
Components in **GROUP 2** colors  
Components in **Types and colors FRONT**

Shaped components available with contrasting edging.  
Is available in two colors.



**OPTIONAL:** p. 290  
A · Extra colors for Top panel, Bottom panel and Shelves  
B · Extra colors for Side panels  
C · Increased Back panel Th 0.8  
D · PLUS clothes-hanging bar



p. 56 Knob and handle positions  
p. 306 Side support panels for Loft beds  
p. 307 Accessories for Loft beds  
p. 315 Metal ladders and guards for Loft beds and Bunk beds

Mattresses, pillows and slatted bed base  
See back cover wing



Metal supporting bars available in the colors:  
Bianco opaco (B17A)  
Alluminio (AL1A)



# HELIX loft beds

Compositions must be completed with wardrobes/wardrobes with shaped side panels (Dpt 56.3) or the side support panels/bookshelves (Dpt 57.1) Ht 225.6, 241.6 or 257.6.

When ordering, a platform bed have to be added.

The external dimensions on the bed side include the floor-standing side panel of the platform bed (Th 2.5).

## Ht 225,6

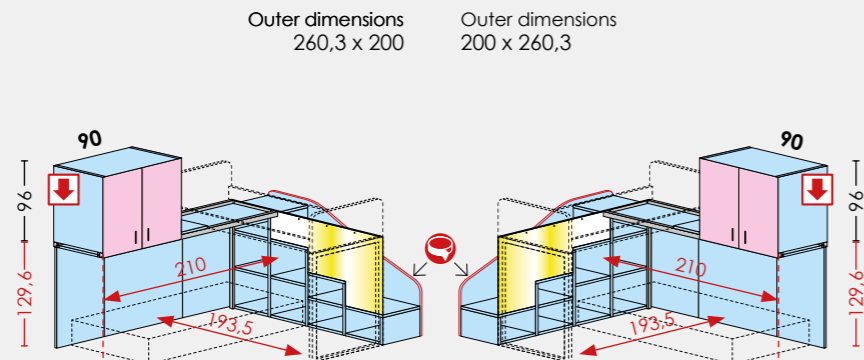

Code	PK40.49A	PK40.50X	
ONE	matte		
	glossy		
CLUB			

## Ht 257,6

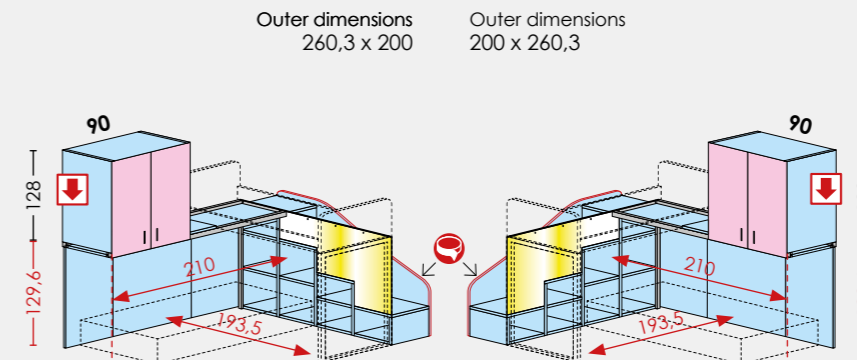

Code	PK40.51D	PK40.52L	
ONE	matte		
	glossy		
CLUB			

## Ht 241,6

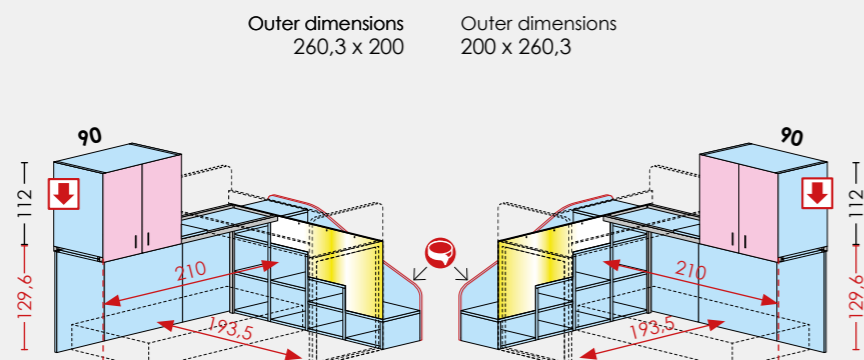

Code	PK41.28N	PK41.29U	
ONE	matte		
	glossy		
CLUB			

### Overall dimensions of the back stair

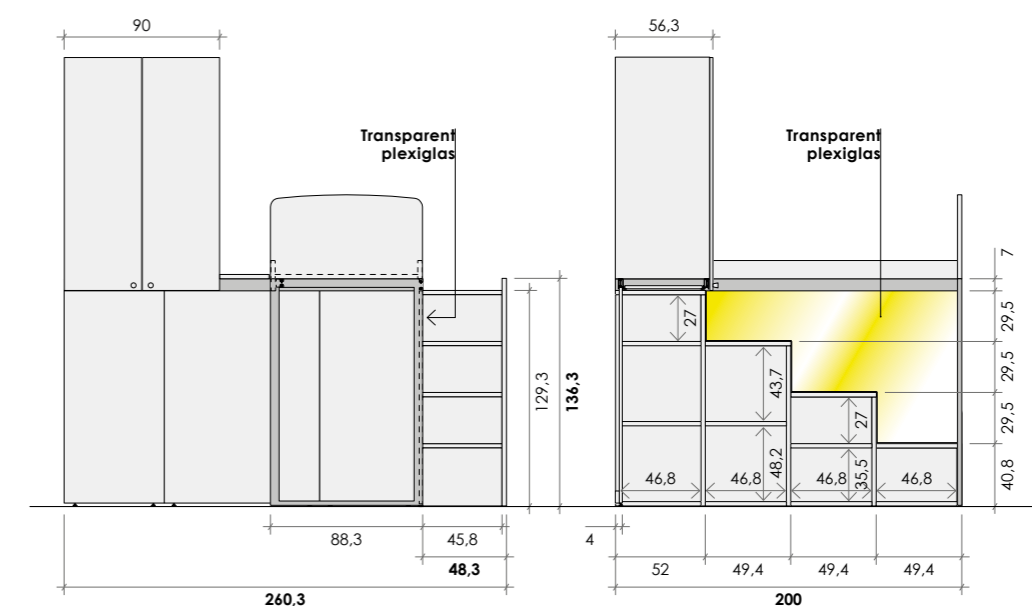

## Ht 184,6 Dpt 88,3

Platform beds  
W 200

Bed internal dimensions 195 x 81. Can be used without base.

1 or more guards must be ordered.

Use the: mattress and bed base 190 x 80

METAL

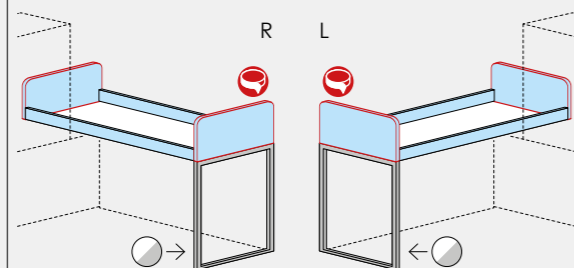

BASE

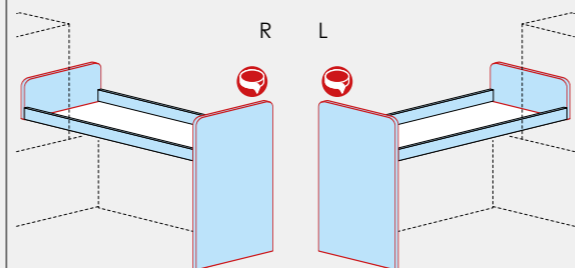

Code	PK40.53S	PK40.54Y	PK40.86C	PK40.87K

ARCO

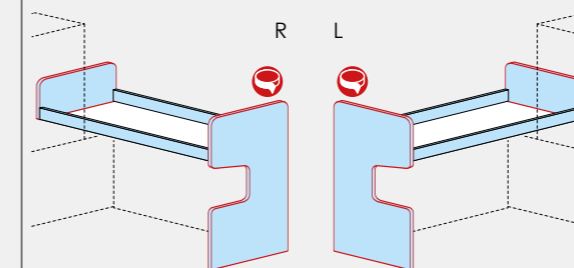

Code	PK40.88R	PK40.89X	

Transparent plexiglas

Th 0,5  
Dpt 147,3  
Ht 94,2

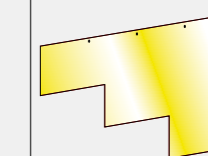

Code	PK40.63X

- Components in **CARCASE** colors
- Components in **GROUP 2** colors
- Components in **Types and colors FRONT**

- Shaped components available with contrasting edging.
- B17A
- AL1A



- OPTIONAL:** p. 290
- A · Extra colors for Top panel, Bottom panel and Shelves
  - B · Extra colors for Side panels
  - C · Increased Back panel Th 0,8
  - D · PLUS clothes-hanging bar



- p. 56 Knob and handle positions
- p. 306 Side support panels for Loft beds
- p. 307 Accessories for Loft beds
- p. 315 Metal ladders and guards for Loft beds and Bunk beds

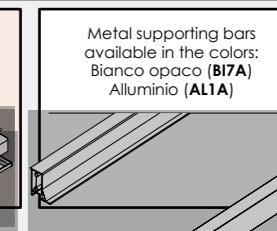

## Side support panels for Loft beds

### Side support panels Dpt 57.1 - Th 2.5

With adjustable  
middle-support feet  
Specify L or R  
(L drawings)

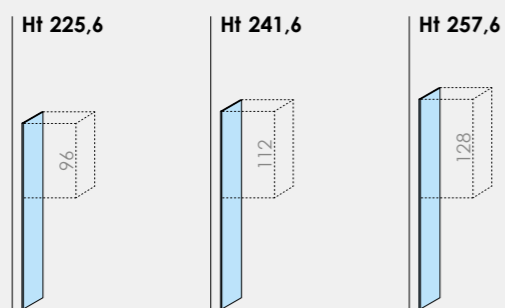

Code	PK39.07B	PK37.70L	PK39.08H			
------	----------	----------	----------	--	--	--

### Side support panels with metal structure and filler side panel Dpt 57.1 - Th 2.5

With adjustable feet

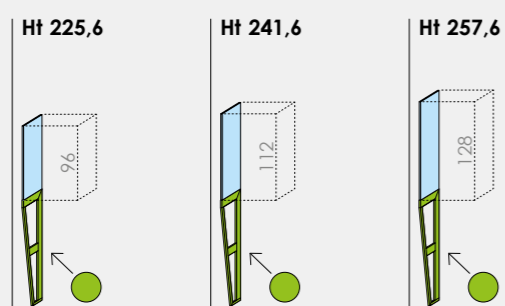

Code	PK39.09Q	PK37.71S	PK39.10M			
------	----------	----------	----------	--	--	--

### Side support panels with to C metal structure and filler side panel Dpt 57.1 - Th 2.5

With adjustable feet

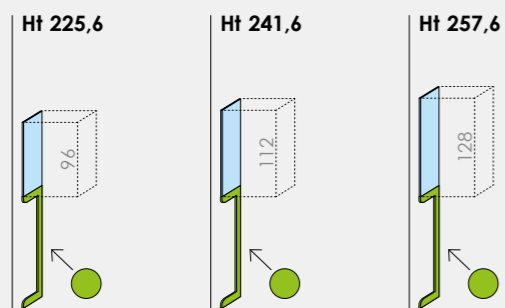

Code	PK37.83L	PK37.84S	PK37.85Y			
------	----------	----------	----------	--	--	--

### SMART support bookshelf Dpt 57.1 - W 33.3

With adjustable  
middle-support feet  
In end elements specify  
L or R (L in the drawing)

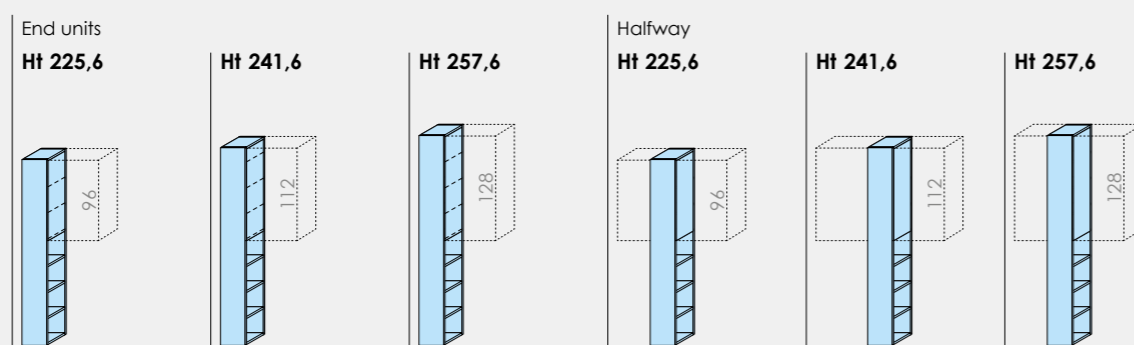

Code	PK39.20S	PK37.75T	PK39.24T	PK39.21Y	PK37.76Z	PK39.25Z
------	----------	----------	----------	----------	----------	----------

Components in **GROUP 2 colors**

Shaped components available with contrasting edging.

\* Price of the element in the GROUP 2 colors (CARCASE colors excluded)

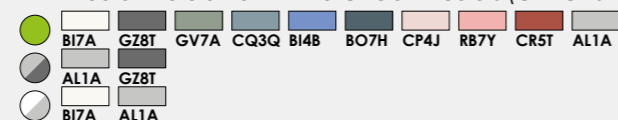

## Accessories for Loft beds

### Movable shelves for wardrobes Dpt 88.7 Dpt 28.6 - Th 2.5

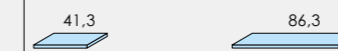

### Movable shelves for bridge units Dpt 56.3 Dpt 51.5 - Th 2.5

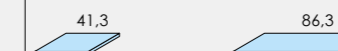

### Roll-up slatted base Ht 3 - Dpt 190 - W 80



Code	PK01.91S	PK01.92Y	PK01.01T	PK01.03F	P07.91G	

### BASIC clothes hanging bar

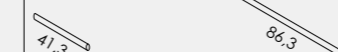

### PLUS clothes hanging bars

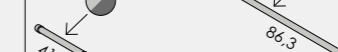

### Metal clothes reacher pole Ht 115

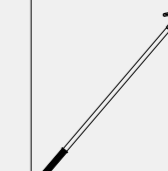

Code	P50.79E	P50.81R	PK01.43C	PK01.45R	PL04.17C	
------	---------	---------	----------	----------	----------	--

### SUMMER end bookshelves W 53.9 - Dpt 21

Shaped shelves are  
always mounted  
32 mm apart.

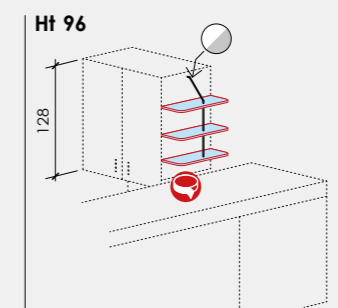
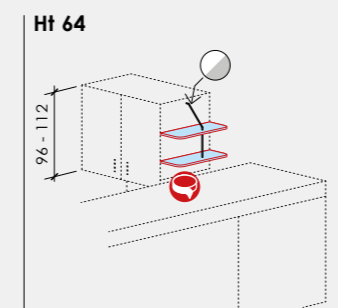

Code	PK20.46Z	PK20.47F		
------	----------	----------	--	--

### WOLLY end bookshelves W 54.3 - Dpt 30

Shaped shelves are  
always mounted  
32 mm apart.

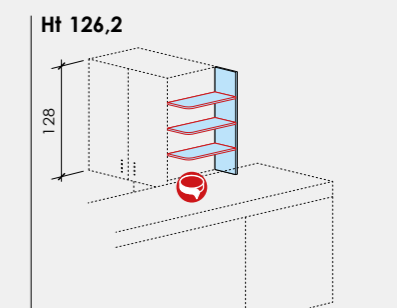
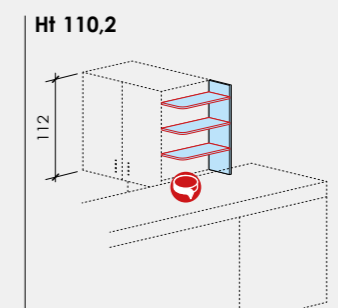
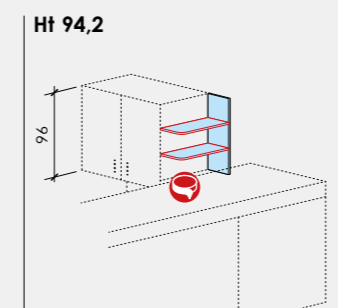

Code	PK20.78D	PK20.80G	PK20.79L
------	----------	----------	----------



# FORMENTERA bunk bed Ht 184.6 - W 200 - Dpt 88.3

Central structures without Shaped side panels.

Use the: mattress and bed base 190 x 80 (for fold-away base 190 x 75)

## W 195 - Dpt 88.3

With open space underneath vault

Without bed base

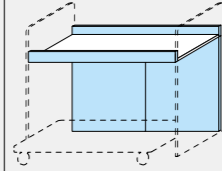

Code **PK40.55E**

With fold-away base

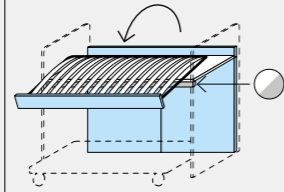

Code **PK40.55ERR**

Without bed base, with pull-out writing-desk top

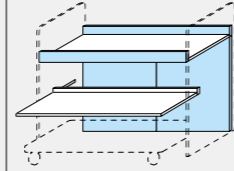

Code **PK40.56M**

With fold-away bed base and pull-out writing-desk top

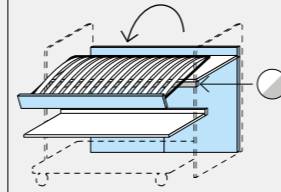

Code **PK40.56MRR**

## Metal bed frames

For FORMENTERA with open space underneath vault

With 4 castor wheels with brake  
W 88 - Dpt 193 - Ht 29



Code **P51.89N**

With 2 feet and 2 castor wheels with brake (reversible)  
W 88 - Dpt 193 - Ht 29



Code **H26.94U**

## W 195 - Dpt 88.3

With slatted bases

For the 2<sup>nd</sup> bed base mattress Ht 17 max.

With bed base

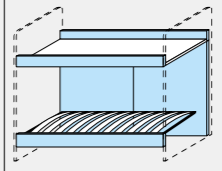

Code **PK40.57T**

With bed base and fold-away bed base

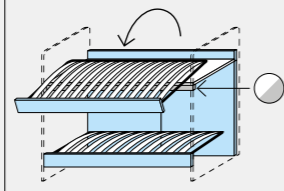

Code **PK40.57TRR**

With bed base and 2<sup>nd</sup> bed base

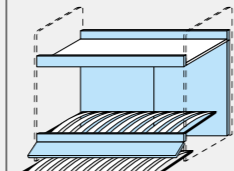

Code **PK40.58Z**

With bed base, 2<sup>nd</sup> bed base and fold-away bed base

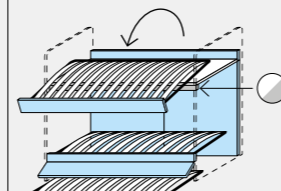

Code **PK40.58ZRR**

## Shaped side panels Th 2.5

Specify R or L

BASE



Code **PK40.60C**

ARCO



Code **PK40.61K**

DUNA

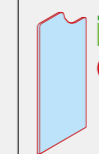

Code **PK40.62R**

## W 195 - Dpt 88.3

With slatted bases and big drawers

With bed base

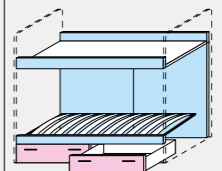

Code **PK40.59F**

ONE matte  
glossy

CLUB

With bed base and fold-away bed base

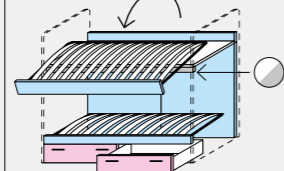

Code **PK40.59FRR**

Roll-up slatted base  
Ht 3 - Dpt 190 - W 80



Code **P07.91G**

Example:

- 1 PK40.60C BASE side panel (L)
- 2 PK40.59F Central structure
- 3 PK40.62R DUNA side panel (R)

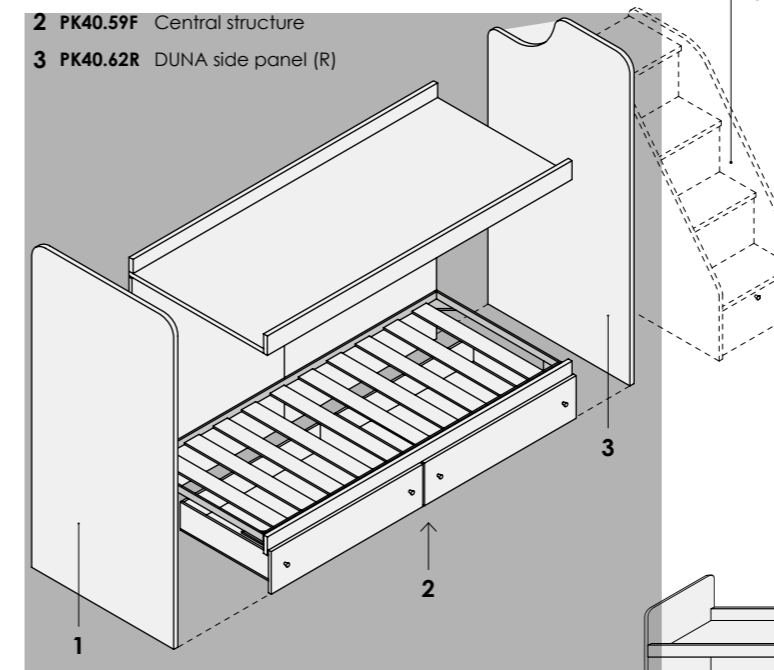

Ladders with shaped sides can only be used against the DUNA side panel.

**Compositions MUST consist of the central structure complete with two shaped side panels, one on the right and one on the left.**

**It is essential to send a drawing of the complete composition to allow the elements to be prepared correctly.**

**When ordering, the shaped side panels, the metal ladder or the ladders with shaped sides have to be added.**

**1 or more guards must be ordered.**

**For the fold-away bed use only mattress W 75.**

Fold-away base movement

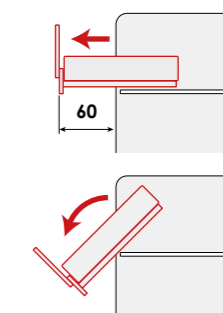

Pull-out writing-desk top

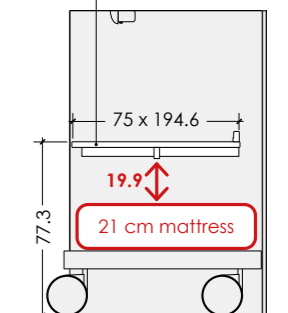

Components in **CARCASE** colors

Components in **GROUP 2** colors

Components in **Types and colors FRONT**

The ladder with shaped sides may be used.

Shaped components available with contrasting edging.

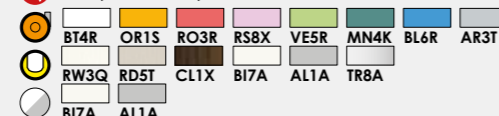

Mattresses, pillows and slatted bed base  
See back cover wing



# SPRINT bunk beds

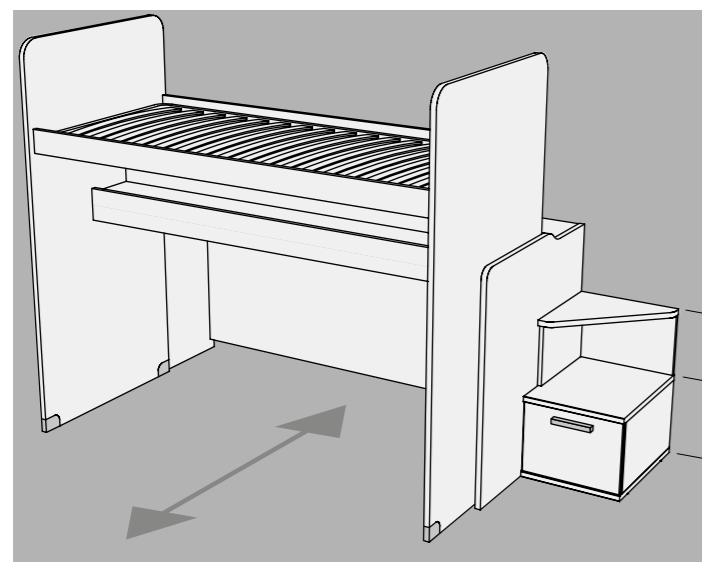

**Pull-out upper bed on wheels with locking brake.**  
**Structural slatted bed base included.**  
**Internal dimensions 195 x 81.**  
**A guard for fitting on the front and the side ladder must be ordered.**  
 Elements can not be modified.

- BASE Ht 180
- NUBE Ht 182.5
- GIANO Ht 189
- WAVE Ht 180

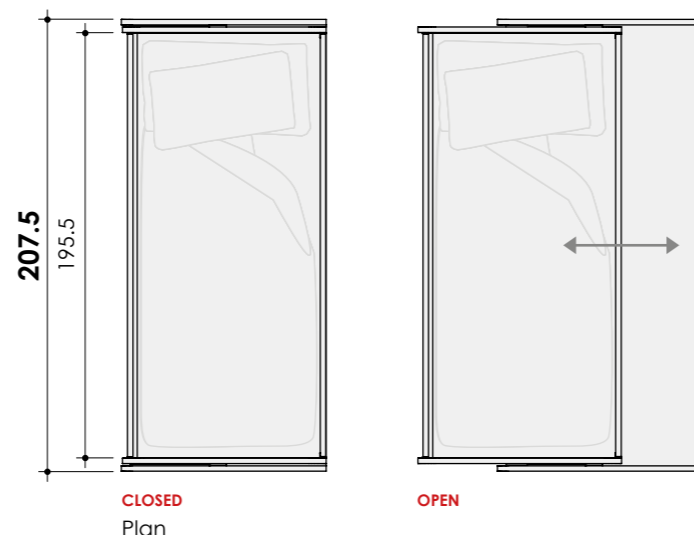
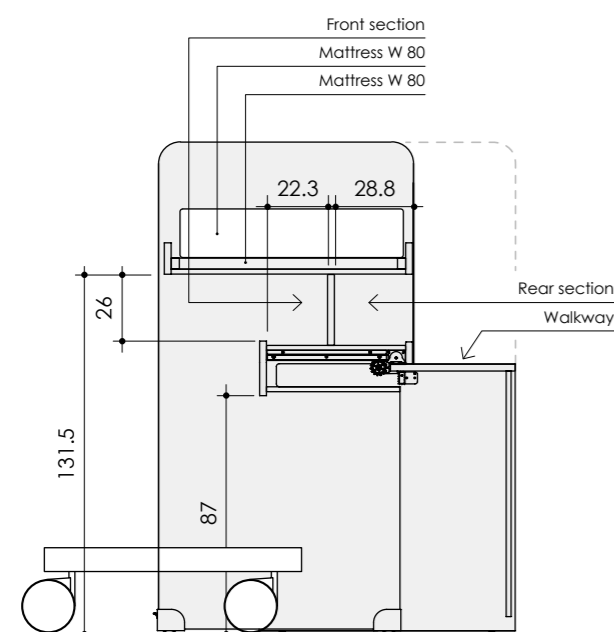
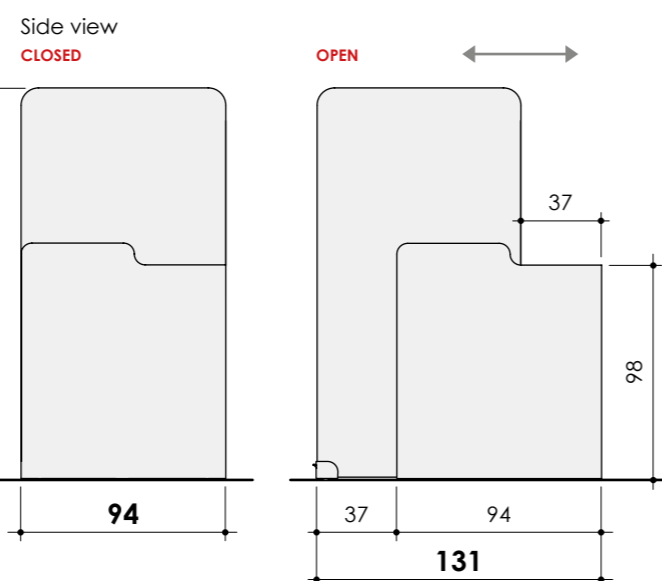

## SPRINT Beds

Structural slatted bed base included.

Use the: mattress 190 x 80

BASE  
Ht 180

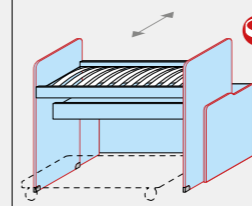

NUBE  
Ht 182.5

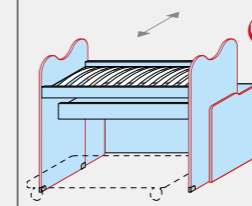

GIANO  
Ht 189

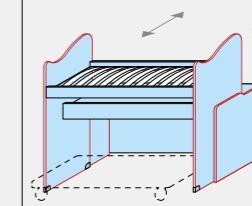

WAVE  
Ht 180

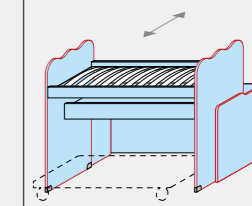

Code	PL44.88L	PL44.89S	PL44.90P	PL44.91V
------	----------	----------	----------	----------

## UP ladder

Reversible.  
With big drawer.

W 45 - Ht 67.5 - Dpt 57.1

- + 50,00 for pair of side panels in **GROUP 2 colors** (carcase colors excluded).
- + 13,00 for big drawer closing retainers.
- + 23,00 for **CHARM** drawers with soft-close "Quadro" type slides.

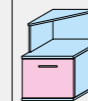

Code	PK40.64D		
ONE	matte		
	glossy		
CLUB			

The **GRETA** ladder for the **MULTIFUNCTION** beds can be used instead of the UP ladder.

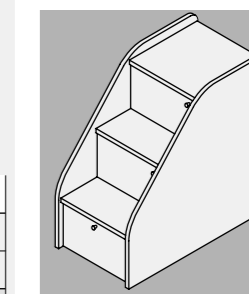

## Metal bed frames

With 4 castor wheels with brake  
W 88 - Dpt 193 - Ht 29

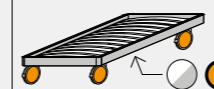

With 2 feet and 2 castor wheels with brake (reversible)  
W 88 - Dpt 193 - Ht 29



Code	P51.89N	H26.94U	
------	---------	---------	--

## Equipped pull-out bed

For bed base W 80  
Use of a roll-up slatted base is recommended

With 2 big drawers and self-braking wheels.  
Ht 33 - W 90 - Dpt 194.6

- + 23,00 for **CHARM** drawers with soft-close "Quadro" type slides.

Use the: mattress 190 x 80

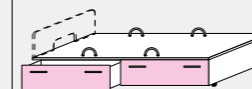

Code	P06.70Q	Code	PL44.22P	P07.91G
ONE	matte			
	glossy			
CLUB				

**Headboard for equipped pull-out beds**  
Can be used as preferred on either side.  
Ht 36 - W 88 - Th 2.5

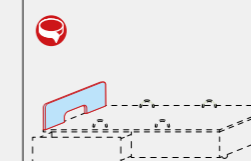

**Roll-up slatted bed base**  
Ht 3 - Dpt 190 - W 80



- Components in **CARCASE** colors
- Components in **GROUP 2** colors
- Components in **Types and colors FRONT**

- Shaped components available with contrasting edging.
- BT4R
- OR1S
- RO3R
- RS8X
- VE5R
- MN4K
- BL6R
- AR3T
- RW3Q
- RD5T
- CL1X
- B17A
- AL1A
- TR8A
- B17A
- AL1A

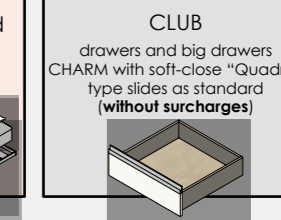



# SLOT bunk beds bed base W 80

1 or more guards and ladder must be ordered.

Use the: mattress 190 x 80

## With slatted bases

Ht 166 - W 202 - Dpt 206  
internal dimensions 193 x 81

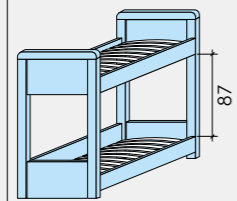

Ht 166 - W 202 - Dpt 206  
internal dimensions 193 x 81

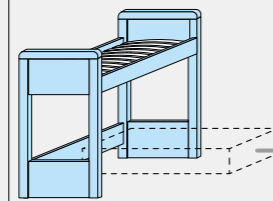

Code	<b>P78.71S</b>	<b>P78.72X</b>
------	----------------	----------------

## Fitted with 3<sup>rd</sup> base and slatted bases

Mattress Ht 17 max  
for 3<sup>rd</sup> bed base

Ht 166 - W 202 - Dpt 206  
internal dimensions 193 x 81

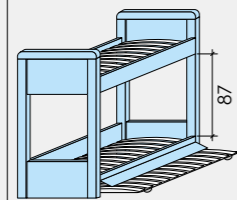

Code	<b>P78.73C</b>
------	----------------

## Metal bed frames

With 4 castor wheels with brake  
W 88 - Dpt 193 - Ht 29

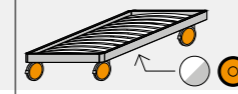

Code	<b>P51.89N</b>
------	----------------

With 2 feet and 2 castor wheels with brake (reversible)  
W 88 - Dpt 193 - Ht 29

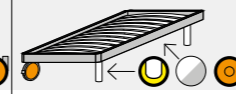

Code	<b>H26.94U</b>
------	----------------

## Fitted with big drawers and slatted bases

Ht 166 - W 91 - Dpt 202  
internal dimensions 193 x 81

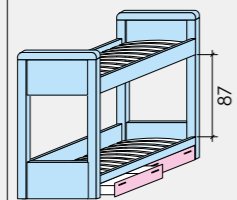

Code	<b>P78.74H</b>
ONE	matte glossy
CLUB	

## Somier

With 4 castor wheels with brake  
W 88 - Dpt 200 - Ht 29

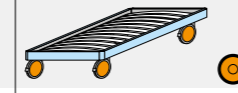

Code	<b>P51.86W</b>
------	----------------

With 2 feet and 2 castor wheels with brake (reversible)  
W 88 - Dpt 200 - Ht 29

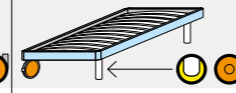

Code	<b>H26.63A</b>
------	----------------

# SLOT bunk beds bed base W 90

1 or more guards and ladder must be ordered.

Use the: mattress 190 x 90 (for pull-out base 190 x 80)

## With slatted bases

Ht 166 - W 100 - Dpt 202  
internal dimensions 193 x 91

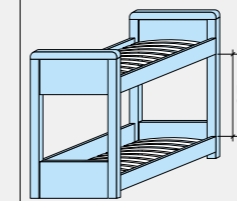

Ht 166 - W 100 - Dpt 202  
internal dimensions 193 x 91

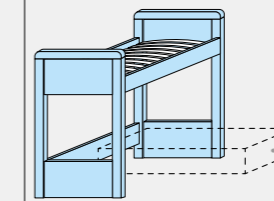

Code	<b>P78.76U</b>	<b>P78.77Z</b>
------	----------------	----------------

## Fitted with 3<sup>rd</sup> base W 80 and slatted bases

Mattress Ht 17 max  
for 3<sup>rd</sup> bed base

Ht 166 - W 100 - Dpt 202  
internal dimensions 193 x 91

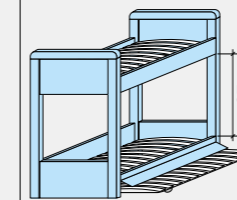

Code	<b>P78.78E</b>
------	----------------

## Metal bed frames

With 4 castor wheels with brake  
W 98 - Dpt 193 - Ht 29



Code	<b>P52.87E</b>
------	----------------

With 2 feet and 2 castor wheels with brake (reversible)  
W 98 - Dpt 193 - Ht 29

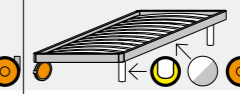

Code	<b>H26.67X</b>
------	----------------

## Fitted with big drawers and slatted bases

Ht 166 - W 101 - Dpt 202  
internal dimensions 193 x 91

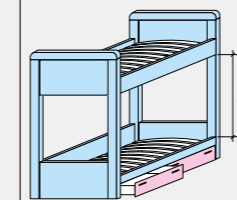

Code	<b>P78.79L</b>
ONE	matte glossy
CLUB	

## Somier

With 4 castor wheels with brake  
W 98 - Dpt 200 - Ht 29

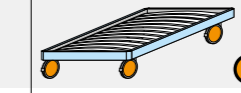

Code	<b>P66.82T</b>
------	----------------

With 2 feet and 2 castor wheels with brake (reversible)  
W 98 - Dpt 200 - Ht 29

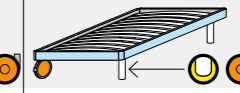

Code	<b>H26.78G</b>
------	----------------

Components in **GROUP 2 colors**  
Components in **Types and colors FRONT**

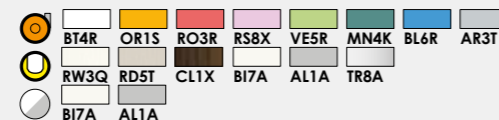

# OSLO bunk beds

Use the: mattress and bed base 190 x 80

Ht 174.8  
Dpt 95.8  
W 203.1

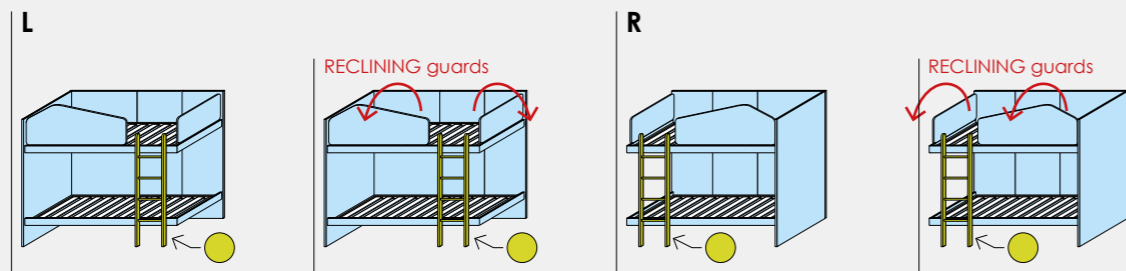

Code	PK40.99C	PK41.00Z	PK41.01F	PK41.02N
------	----------	----------	----------	----------

Self-supporting and structural slatted bed bases 190x80 included.  
A closing panel Th 1.8 is included under the bed bases.  
Structural metal ladder included.  
Fall protections for top bed in melamine-faced finish Th 2.5 included.  
**The metal ladder and protections are dedicated, they cannot be replaced.**  
The panels (rear and side) are always secured to the wall.

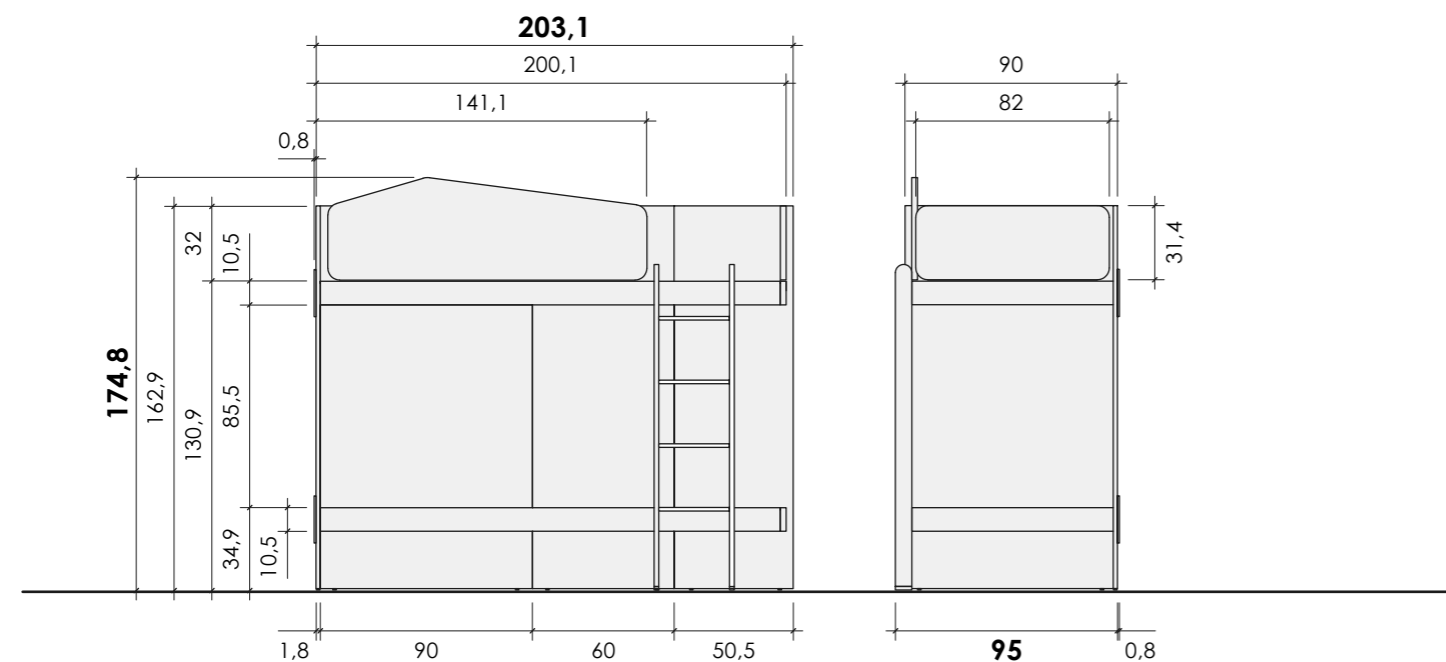
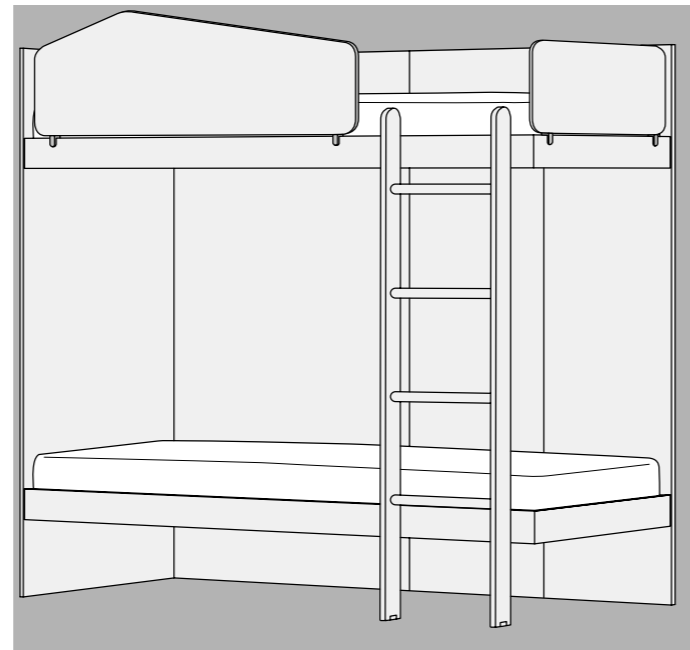

Components in **GROUP 2** colors  
Is available in two colors.

Shaped components available with contrasting edging.

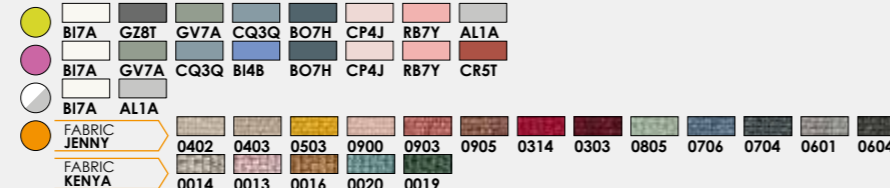

# Metal ladders and guards for Loft beds and Bunk beds

**Metal ladders**  
With fixing  
Ht 148.7 - W 35



Code	P97.75Q
------	---------

Ht 162.8 - W 35



For beds with fold-away base

Code	PK01.90L
------	----------

**FLIK guards**  
Melamine-coated.  
Ht 35 - Th 2.5

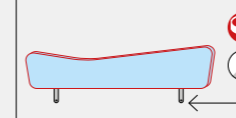

W	Code
150	PL51.09P
183	PL51.49L

**POLDO guards**  
Melamine-coated.  
Ht 24 - Th 2.5

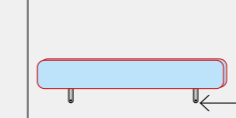

Code
PL51.10L
PL51.50G

**POLDO guards**  
Melamine-faced, padded and covered with fabric. Removable.  
Ht 24 - Th 3.5

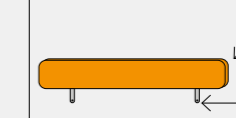

Code
PL51.11S
PL51.51P

**POLDO guards**  
Melamine-faced, padded and covered with fabric with 3 pockets. Removable.  
Ht 24 - Th 3.5

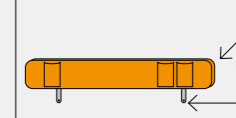

Code
PL51.12Y
PL51.52V

**LONG guards**  
In polyurethane varnished.  
Ht 29



W	Code
150	P97.13C
183	P97.14H

**LONG guards**  
In polyurethane varnished.  
Ht 29  
**RECLINING**

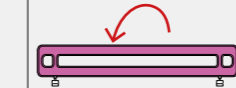

Code
P96.95V
P96.96A

Use the **LONG RECLINING** guard in combination with the **KINTAI** loft bed and the **FORMENTERA** bunk bed (not on beds with fold-away base).

**LOVE guards**  
Melamine-coated.  
Ht 30 - Th 1.8

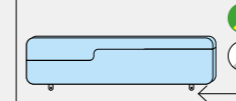

W	Code
150	P07.89W
183	P07.90B

**BALOON guard**  
Melamine-coated.  
Ht 40 - Th 2.5

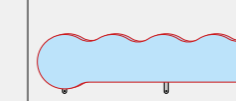

Code
-
P99.00P

We do not recommend you use beds with folding base.



Mattresses, pillows and slatted bed base  
See back cover wing

# MARGOT container ladder with shaped sides

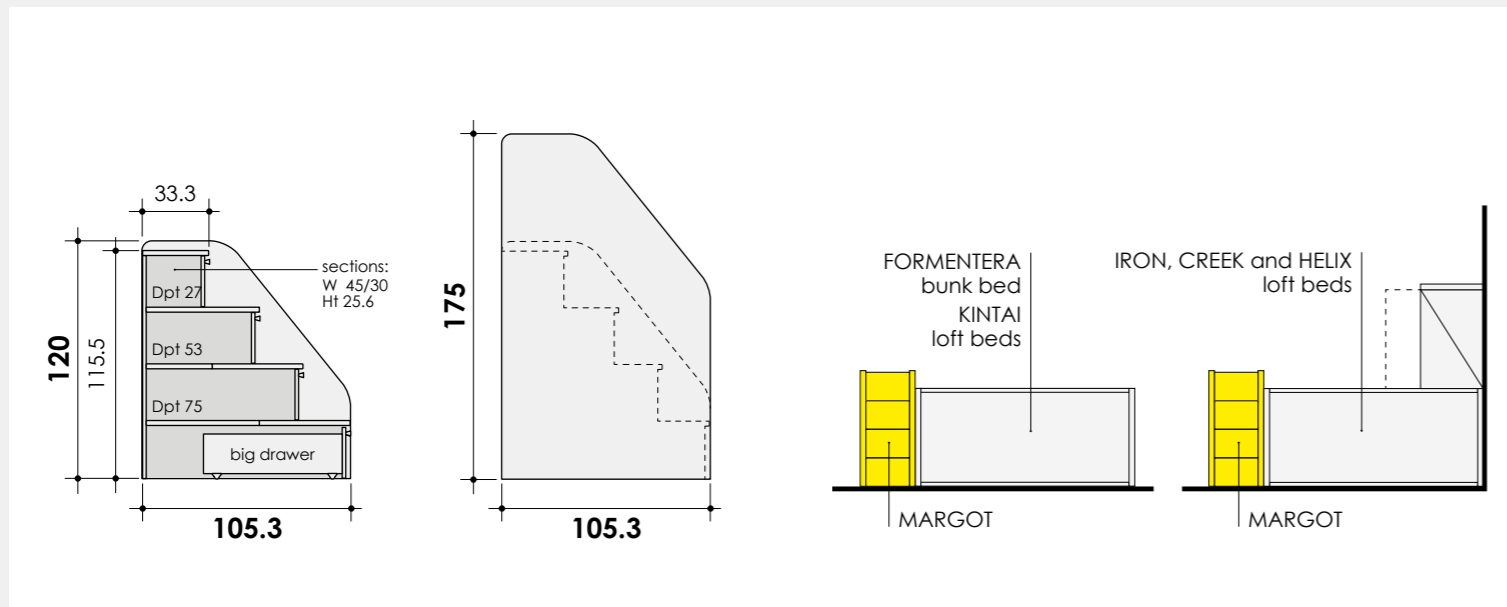

**W 50**  
Ht 120  
Dpt 105.3

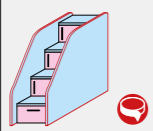

**W 50**  
Ht 175  
Dpt 105.3

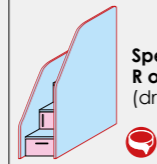

Specify  
R or L  
(drawing shows R)

<b>Code</b>	<b>P97.43R</b>	<b>P97.45B</b>		
ONE	matte			
	glossy			
CLUB				

**W 35**  
Ht 120  
Dpt 105.3

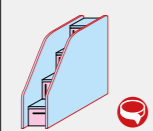

**W 35**  
Ht 175  
Dpt 105.3

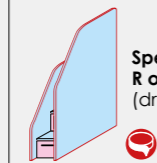

Specify  
R or L  
(drawing shows R)

<b>Code</b>	<b>P97.46G</b>	<b>P97.48T</b>		
ONE	matte			
	glossy			
CLUB				

# GRETA container ladder with shaped sides with PLATFORM

This version of GRETA CANNOT be used with KINTAI

**! PEDANA should be used resting against the wall.**  
PEDANA is also able to take modular units  
Dpt 56.3 - 45 - 32.5 (W 45 only)

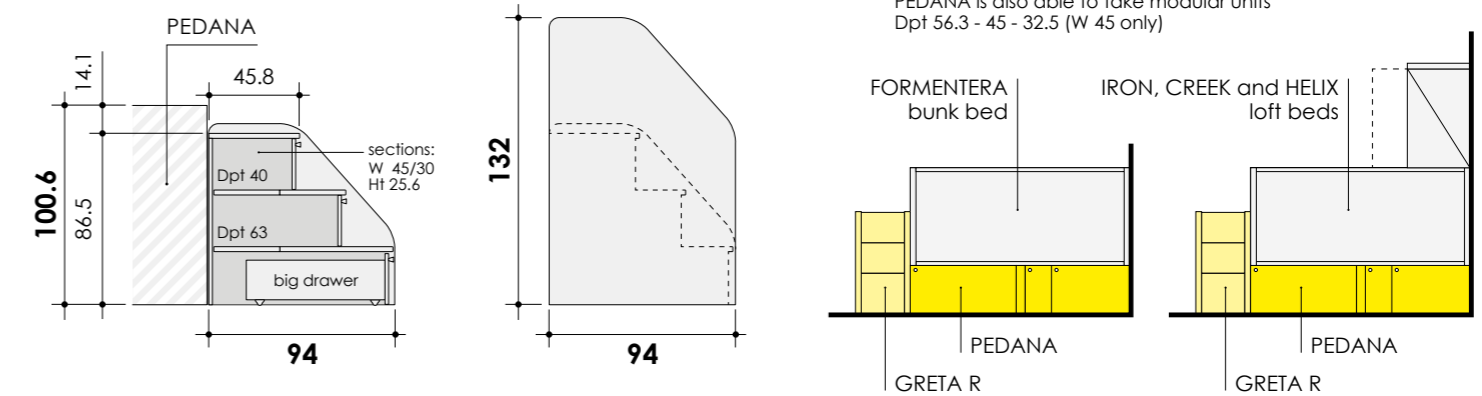

**Ladder W 50**  
Specify R or L  
(drawing shows L)

**W 250**  
Ht 100  
Dpt 94

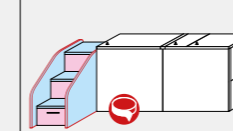

**W 250**  
Ht 132  
Dpt 94

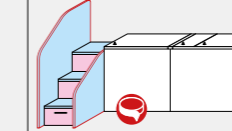

<b>Code</b>	<b>P97.49Y</b>	<b>P97.51K</b>		
ONE	matte			
	glossy			
CLUB				

**Ladder W 35**  
Specify R or L  
(drawing shows L)

**W 235**  
Ht 100  
Dpt 94

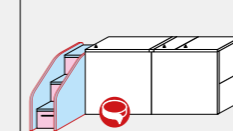

**W 235**  
Ht 132  
Dpt 94

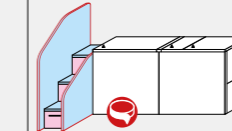

<b>Code</b>	<b>P05.22A</b>	<b>P05.24M</b>		
ONE	matte			
	glossy			
CLUB				

- Components in **CARCASE** colors
- Components in **GROUP 2** colors
- Components in **Types and colors FRONT**
- Shaped components available with contrasting edging.

# GRETA container ladder with shaped sides with PLATFORM

**Ladder W 50**  
Specify R or L  
(drawing shows L)

**W 250**  
Ht 100  
Dpt 94

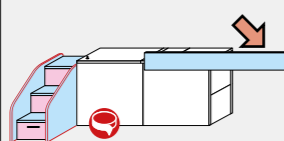

**W 250**  
Ht 132  
Dpt 94

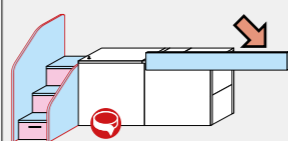

<b>Code</b>	<b>P97.52Q</b>	<b>P97.54A</b>		
ONE	matte glossy			
CLUB				

**Ladder W 35**  
Specify R or L  
(drawing shows L)

**W 235**  
Ht 100  
Dpt 94

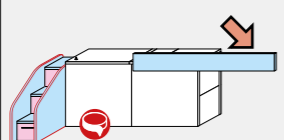

**W 235**  
Ht 132  
Dpt 94

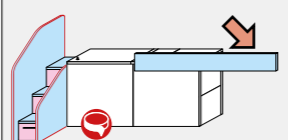

<b>Code</b>	<b>P05.45A</b>	<b>P05.47M</b>		
ONE	matte glossy			
CLUB				

**Ladder W 50 with Container unit Dpt 32.5**  
Specify R or L  
(drawing shows L)

**Ht 225.6** - W 94 - Dpt 280.7

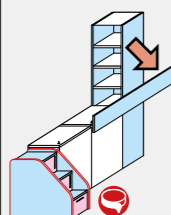

**Ht 241.6** - W 94 - Dpt 280.7

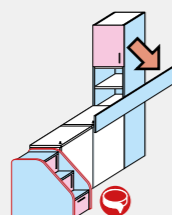

**Ht 241.6** - W 94 - Dpt 280.7

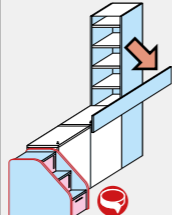

**Ht 257.6** - W 94 - Dpt 280.7

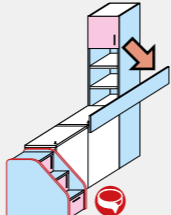

**Ht 257.6** - W 94 - Dpt 280.7

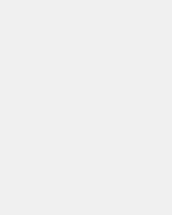

**Ht 257.6** - W 94 - Dpt 280.7

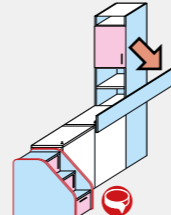

<b>Code</b>	<b>PK40.71Q</b>	<b>PK40.72W</b>	<b>PK41.30R</b>	<b>PK41.31X</b>	<b>PK41.32D</b>	<b>PK40.73C</b>	<b>PK40.74K</b>	<b>PK40.75R</b>		
ONE	matte glossy									
CLUB										

**Ladder W 35 with Container unit Dpt 32.5**  
Specify R or L  
(drawing shows L)

**Ht 225.6** - W 94 - Dpt 265.7

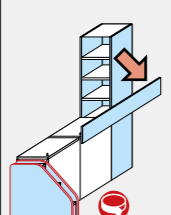

**Ht 241.6** - W 94 - Dpt 265.7

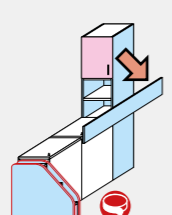

**Ht 241.6** - W 94 - Dpt 265.7

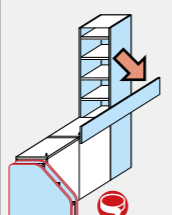

**Ht 257.6** - W 94 - Dpt 265.7

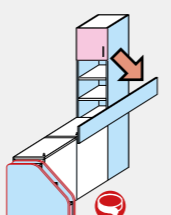

**Ht 257.6** - W 94 - Dpt 265.7

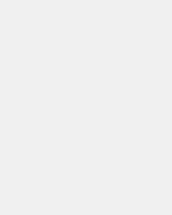

<b>Code</b>	<b>PK40.76X</b>	<b>PK40.77D</b>	<b>PK41.33L</b>	<b>PK41.34S</b>	<b>PK41.35Y</b>	<b>PK40.78L</b>	<b>PK40.79S</b>	<b>PK40.80P</b>		
ONE	matte glossy									
CLUB										

- Components in **CARCASE** colors
- Components in **GROUP 2** colors
- Components in **Types and colors FRONT**

- Shaped components available with contrasting edging.
- Finishing panel for KINTAI equipped overhead composition. For installation instead of the unfinished fixing strip.

**This version of GRETA CAN ONLY be used with KINTAI**

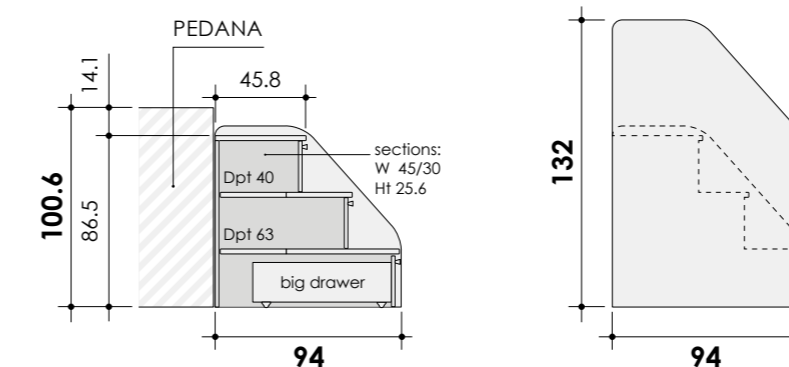

PEDANA is also able to take modular units  
Dpt 56.3 - 45 - 32.5 (W 45 only)



**PEDANA should be used resting against the wall.**

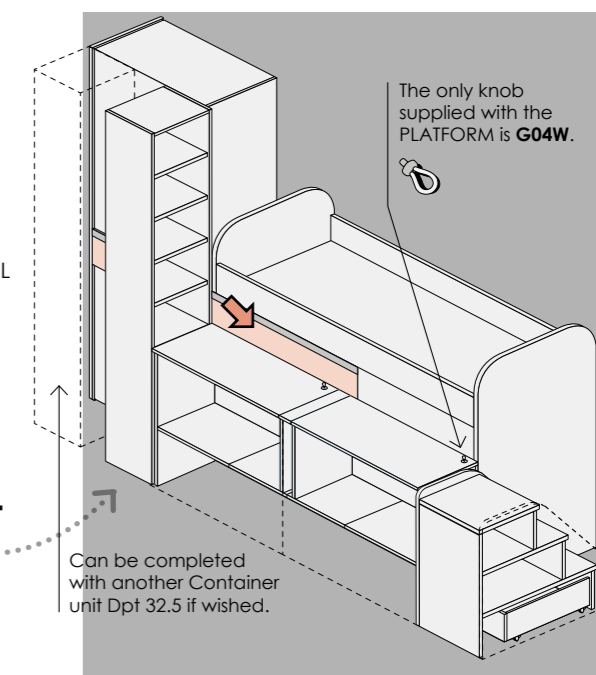
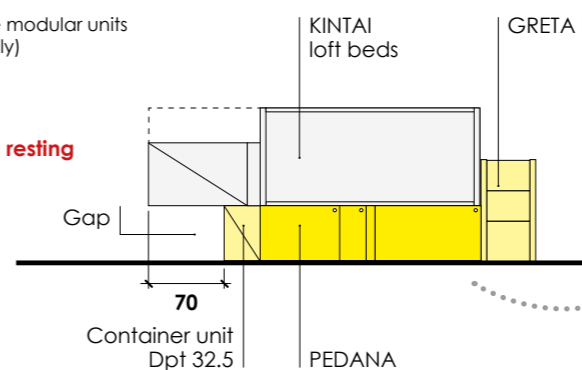

# CLIVIA container ladder with shaped sides

CLIVIA CAN ONLY be used with KINTAI

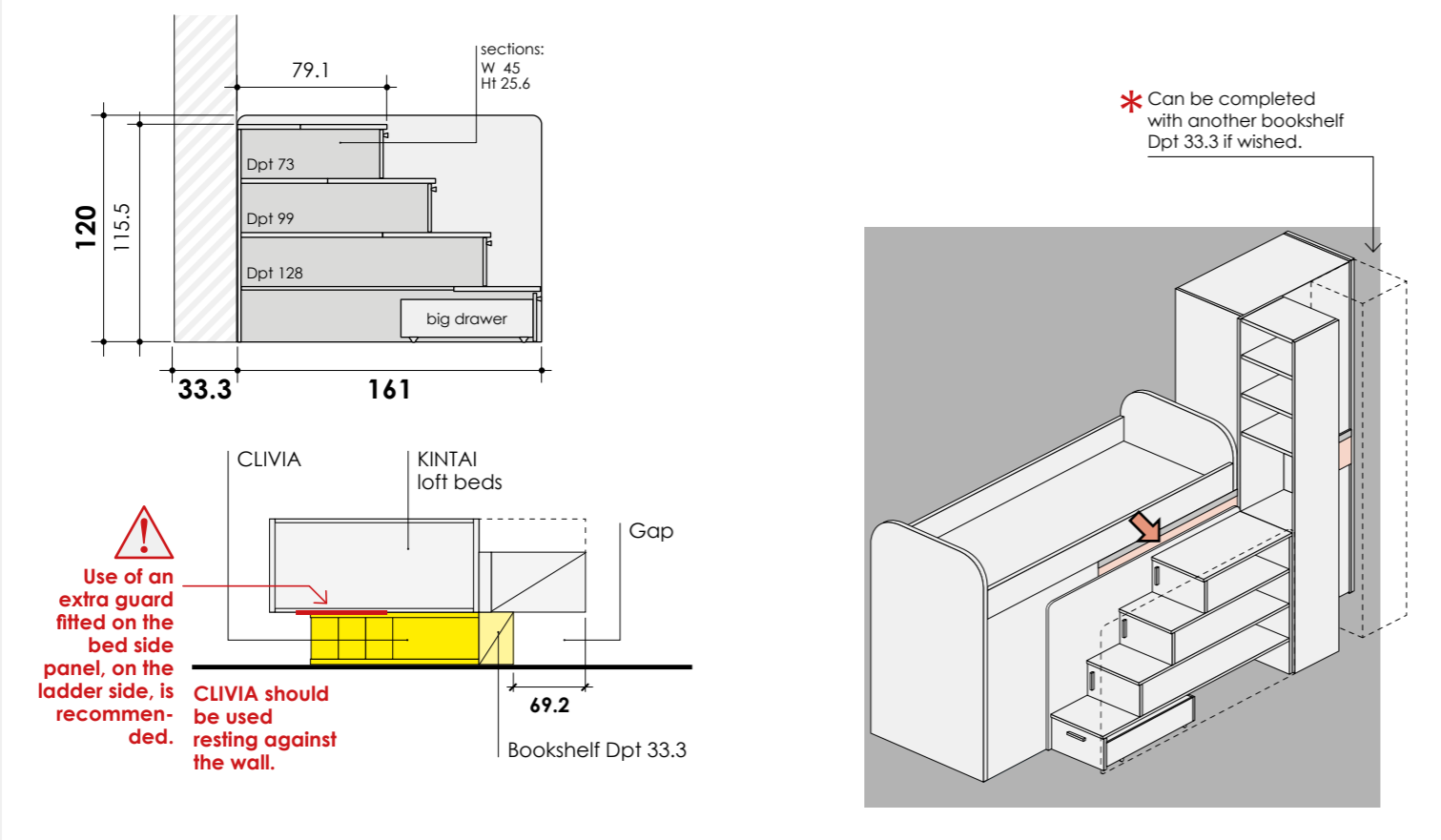

# DALIA container ladder with shaped sides

DALIA CANNOT be used with KINTAI

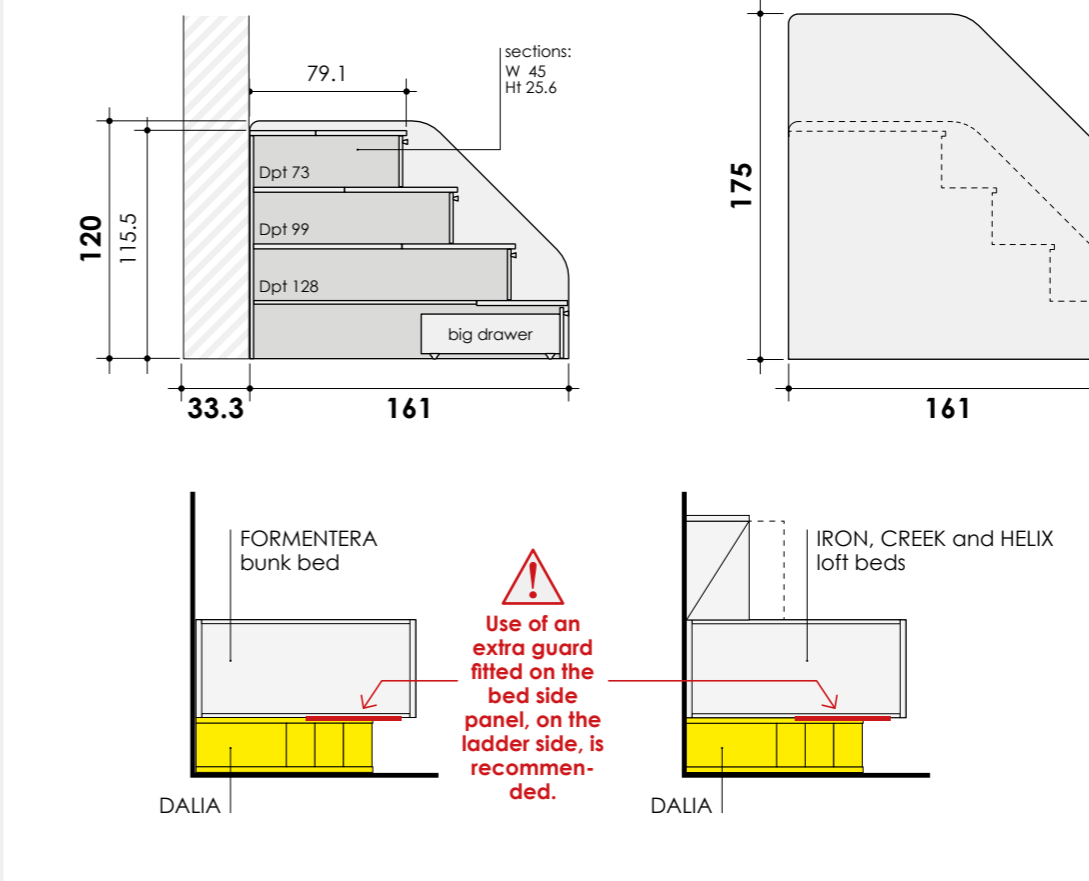

	Ht 225.6 W 50 Dpt 194.5	Bookshelves W 50 Dpt 33.3 Ht 225.6	Ht 241.6 W 50 Dpt 194.5	Bookshelves W 50 Dpt 33.3 Ht 241.6	Ht 257.6 W 50 Dpt 194.5	Bookshelves W 50 Dpt 33.3 Ht 257.6
Code	PK40.91A	PK40.92G	PK41.36E	PK41.37M	PK40.93P	PK40.94V
ONE	matte					
	glossy					
CLUB						

	W 50 Ht 120 Dpt 161	W 50 Ht 175 Dpt 161 Specify R or L (drawing shows L)	Ht 225.6 W 50 Dpt 195	Ht 241.6 W 50 Dpt 195	Ht 257.6 W 50 Dpt 195
Code	P97.68B	P97.70N	PK40.95B	PK41.38T	PK40.96H
ONE	matte				
	glossy				
CLUB					

- Components in **GROUP 2 colors**
- Components in **Types and colors FRONT**
- Shaped components available with contrasting edging.
- Finishing panel for KINTAI equipped overhead composition. For installation instead of the unfinished fixing strip.



# HAPPY equipped bunk bed, bed base W 90

Slatted structural bed bases. Underneath the top bed there is a finishing panel in Bianco opaco (BI7A).

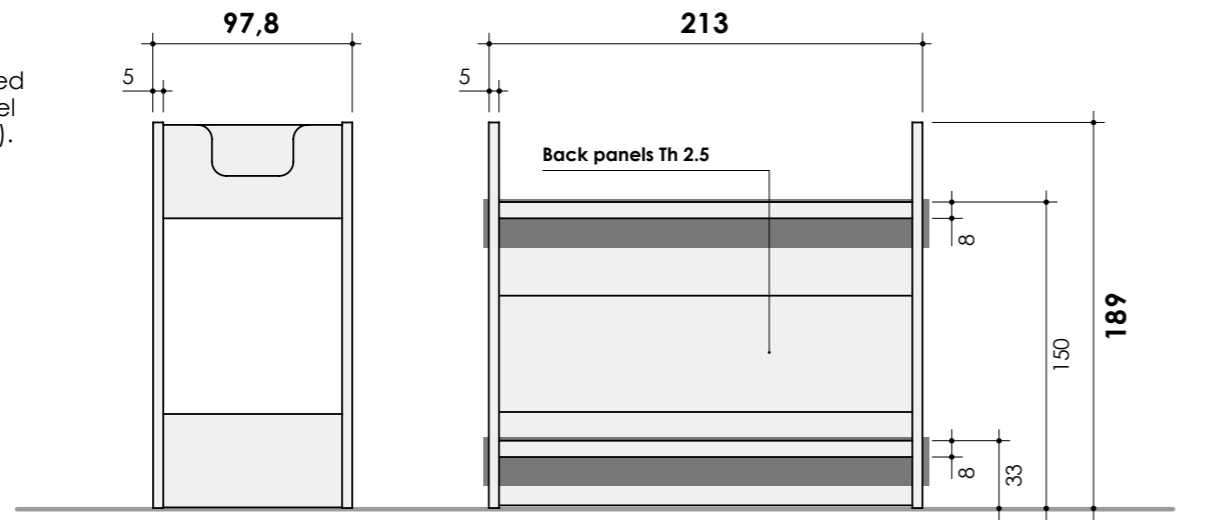

Use the: mattress 200 x 90 (for pull-out base 190 x 80)

Slatted structural bed bases. Underneath the top bed there is a finishing panel in Bianco opaco (BI7A).

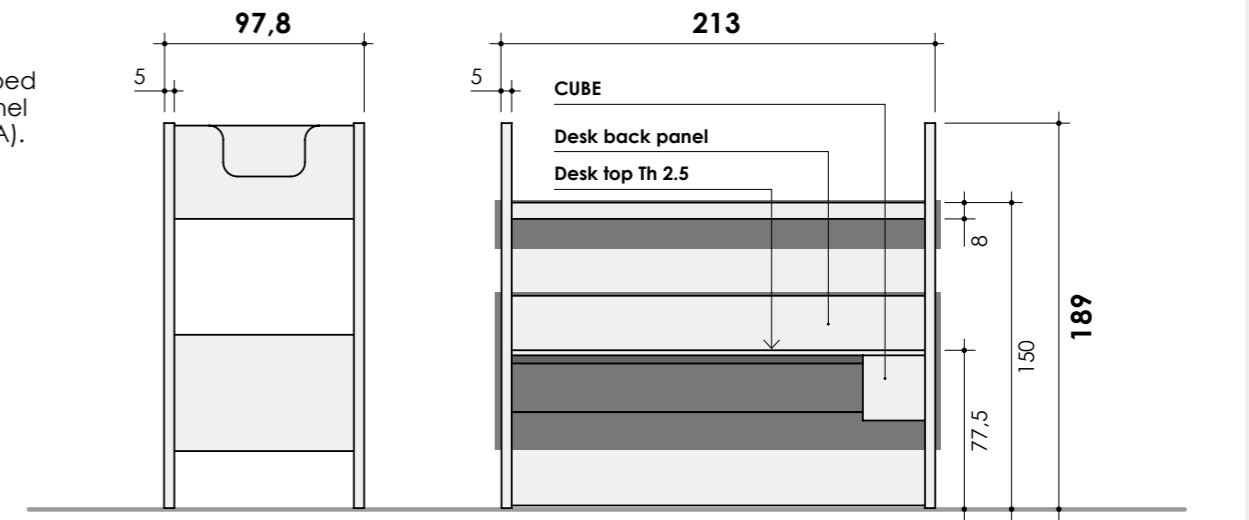

Use the: mattress 200 x 90

## With slatted base

Specify R or L (drawing shows L)

Specify R or L (drawing shows L)

Specify R or L (drawing shows L)

Specify R or L (drawing shows L)

Ht 189  
Dpt 213  
W 97,8

Code	PL58.10R	PL58.11X	PL58.12D	PL58.13L
------	----------	----------	----------	----------

## Fitted with pull-out base W 80 and slatted base

For the pull-out base mattress Ht 17 max.

Specify R or L (drawing shows L)

Specify R or L (drawing shows L)

Specify R or L (drawing shows L)

Specify R or L (drawing shows L)

Ht 189  
Dpt 213  
W 97,8

Code	PL58.14S	PL58.15Y	PL58.16E	PL58.17M
------	----------	----------	----------	----------

## Fitted with big drawers and slatted base

Specify R or L (drawing shows L)

Specify R or L (drawing shows L)

Specify R or L (drawing shows L)

Specify R or L (drawing shows L)

Ht 189  
Dpt 213  
W 97,8

Code	PL58.18T	PL58.19Z	PL58.20W	PL58.21C
ONE	matte			
	glossy			
CLUB				

Components in GROUP 2 colors  
Components in Types and colors FRONT



1 or more guards and ladder must be ordered.

## With desk

Only with desk back panel.

The CUBE can be placed both on the right and the left.

Specify R or L (drawing shows L)

Specify R or L (drawing shows L)

Specify R or L (drawing shows L)

Specify R or L (drawing shows L)

Ht 189  
Dpt 213  
W 97,8

Code	PL58.58Q	PL58.59W	PL58.60T	PL58.61Z
------	----------	----------	----------	----------

## With desk

The CUBE can be placed both on the right and the left.

Specify R or L (drawing shows L)

Specify R or L (drawing shows L)

Specify R or L (drawing shows L)

Specify R or L (drawing shows L)

Ht 189  
Dpt 213  
W 97,8

Code	PL58.22K	PL58.23R	PL58.24X	PL58.25D
------	----------	----------	----------	----------

## With empty unit

All the beds in the GOLF range can be placed inside the unit with a depth below 203 cm.

Specify R or L (drawing shows L)

Specify R or L (drawing shows L)

Specify R or L (drawing shows L)

Specify R or L (drawing shows L)

Ht 189  
Dpt 213  
W 97,8

Code	PL58.26L	PL58.27S	PL58.28Y	PL58.29E
------	----------	----------	----------	----------





# HAPPY equipped bunk bed, bed base W 90 L-SHAPED

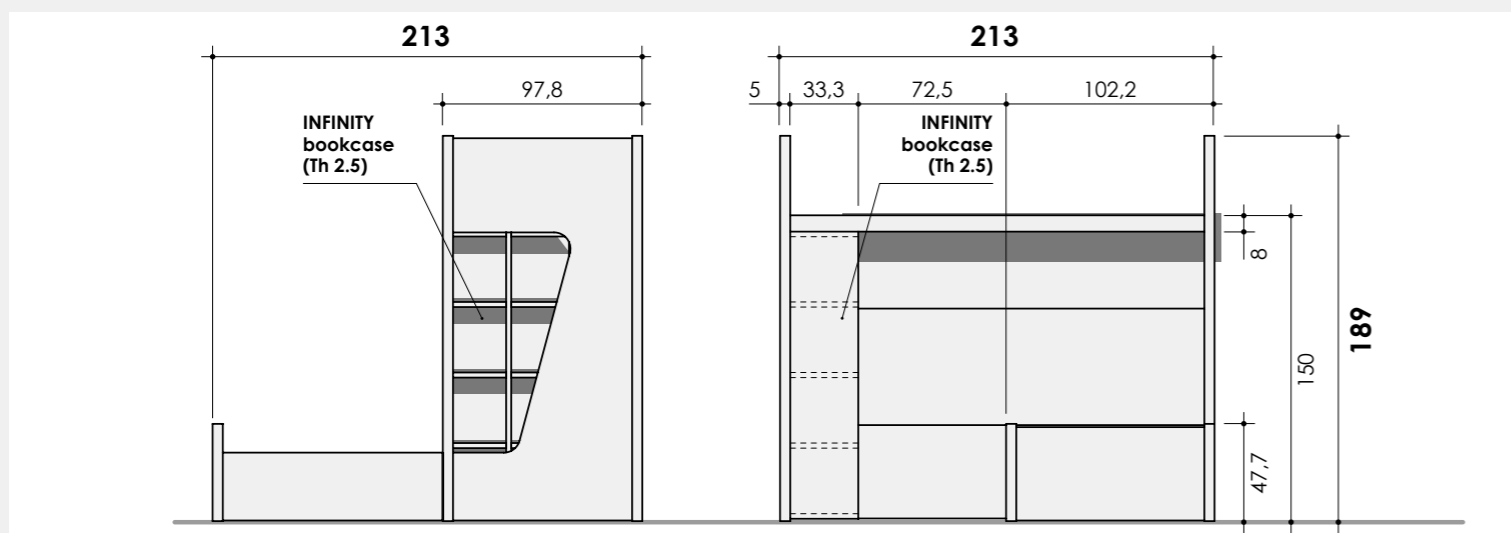

Use the: mattress 200 x 90 (for pull-out base 190 x 80)

## With slatted base

### Without bookcase

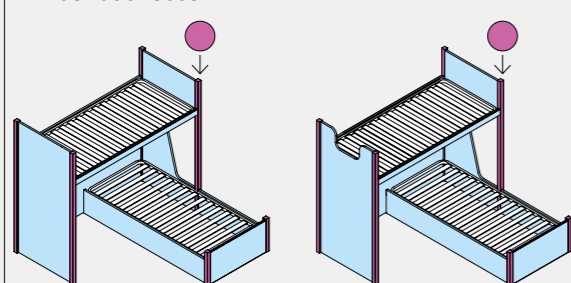

### With bookcase

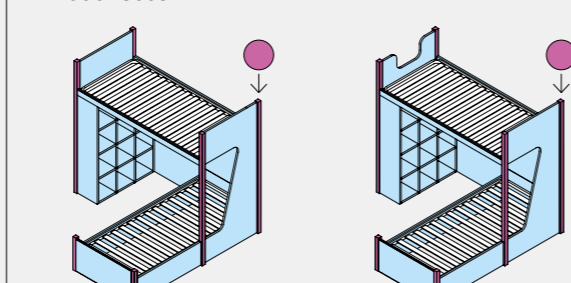

Specify R or L  
(drawing shows R)  
Ht 189  
Dpt 213  
W 213

Code	PL58.30B	PL58.31H	PL58.32Q	PL58.33W
------	----------	----------	----------	----------

## Fitted with pull-out base W 80 and slatted base

For the pull-out base mattress Ht 17 max.

Specify R or L  
(drawing shows R)  
Ht 189  
Dpt 213  
W 213

### Without bookcase

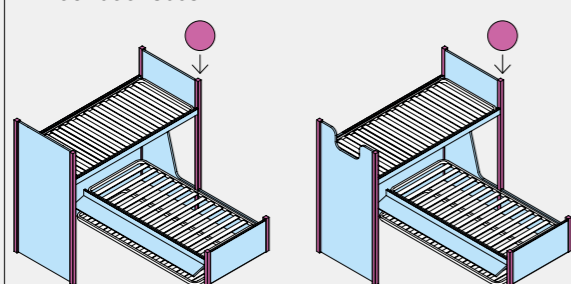

Code	PL58.34C	PL58.35K		
------	----------	----------	--	--

## Fitted with big drawers and slatted base

Specify R or L  
(drawing shows R)  
Ht 189  
Dpt 213  
W 213

### Without bookcase

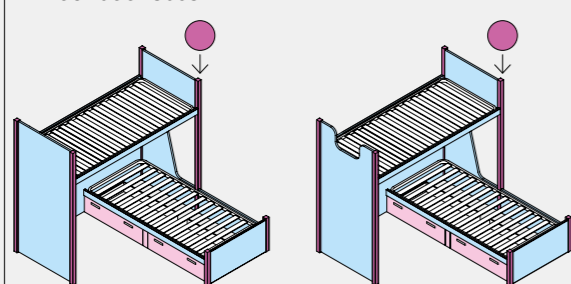

Code	PL58.36R	PL58.37X		
ONE	matte			
	glossy			
CLUB				

Components in GROUP 2 colors  
Components in Types and colors FRONT

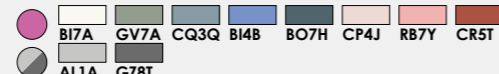

1 or more guards and ladder must be ordered.

# HAPPY equipped bunk bed, bed base W 90 WITH WALK-IN WARDROBE

Slatted structural bed bases. Underneath the top bed there is a finishing panel in Bianco opaco (B17A). Walk-in wardrobes are provided with 2 rows of shelves, 2 clothes rails and battery-powered (anti-bacterial) interior lighting with movement sensor.

Side view

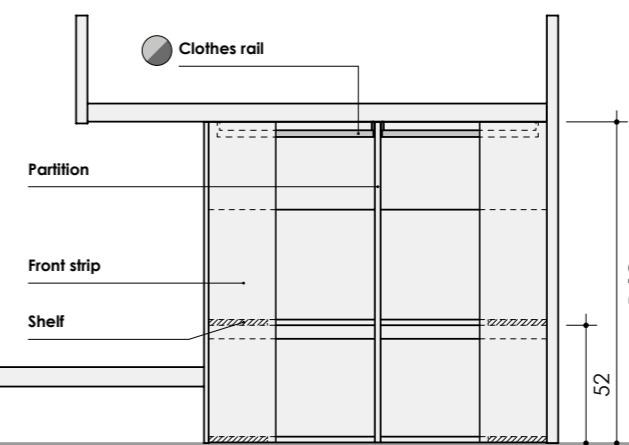

Plan

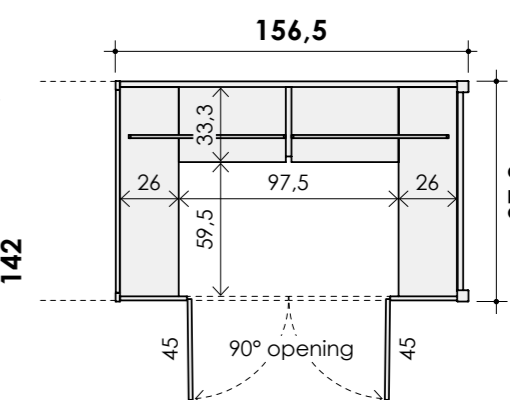

Use the: mattress 200 x 90 (for pull-out base 190 x 80)

## With slatted base

Specify R or L  
(drawing shows R)  
Ht 189  
Dpt 364,5  
W 97,8

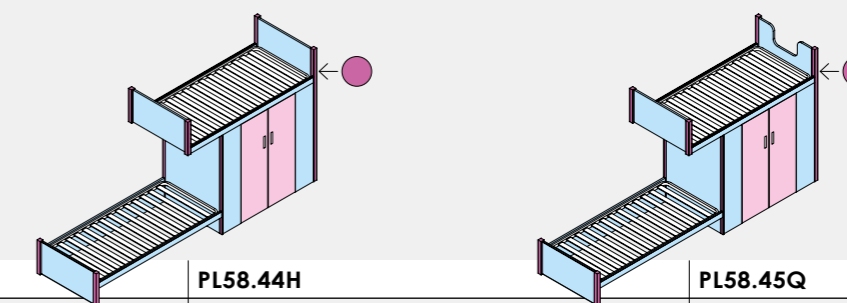

Code	PL58.44H	PL58.45Q
ONE	matte	
	glossy	
CLUB		

## Fitted with pull-out base W 80 and slatted base

For the pull-out base mattress Ht 17 max.

Specify R or L  
(drawing shows R)  
Ht 189  
Dpt 364,5  
W 97,8

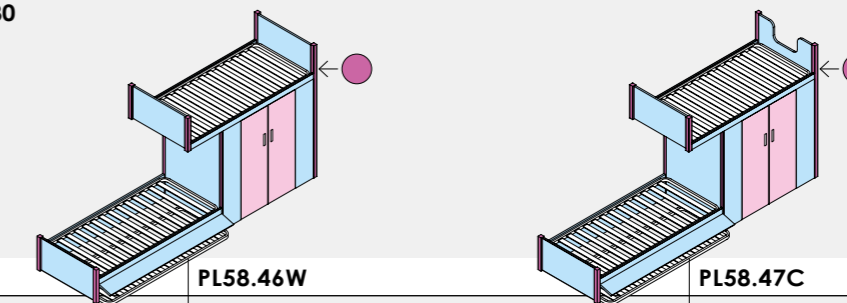

Code	PL58.46W	PL58.47C
ONE	matte	
	glossy	
CLUB		

## Fitted with big drawers and slatted base

Specify R or L  
(drawing shows R)  
Ht 189  
Dpt 364,5  
W 97,8

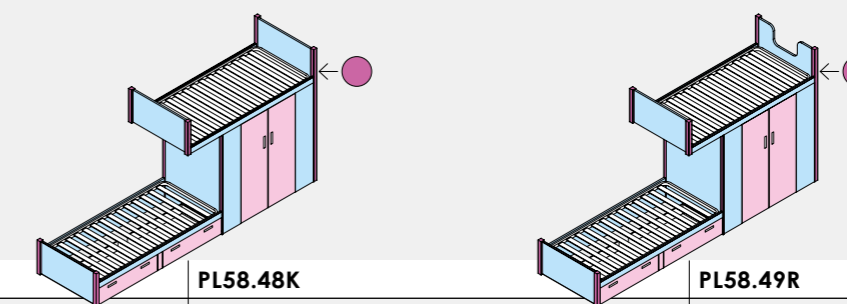

Code	PL58.48K	PL58.49R
ONE	matte	
	glossy	
CLUB		

Mattresses, pillows and slatted bed base  
See back cover wing



# HAPPY single beds, bed base W 90

Slatted structural bed bases.

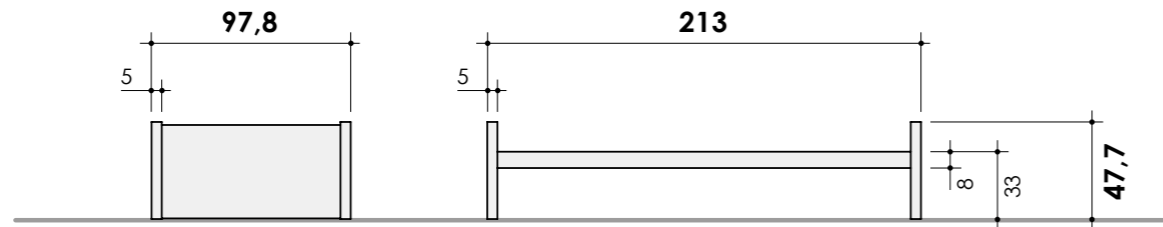

Use the: mattress 200 x 90 (for pull-out base 190 x 80)

With slatted base

Ht 47,7  
Dpt 213  
W 97,8

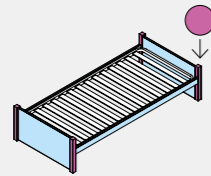

Code	PL58.03E			
------	----------	--	--	--

Fitted with pull-out base W 80 and slatted base

For the pull-out base mattress Ht 17 max.

Ht 47,7  
Dpt 213  
W 97,8

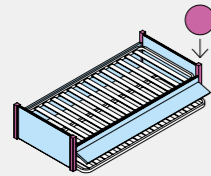

Code	PL58.06Z			
------	----------	--	--	--

Fitted with big drawers and slatted base

Ht 47,7  
Dpt 213  
W 97,8

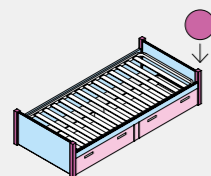

Code	PL58.09U			
ONE	matte			
	glossy			
CLUB				

Components in GROUP 2 colors  
Components in Types and colors FRONT

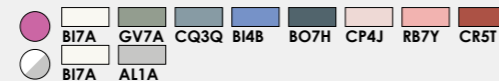

# Accessories for HAPPY

Guards long and short

Ht	37,3	Ht	37,3	Ht	30	Specify R or L (drawing shows R)	Ht	37,3	Ht	37,3
Th	2,5	Th	2,5	Th	2,7		Th	2,5	Th	2,5
W	202	W	202	W	203		W	162,5	W	162,5

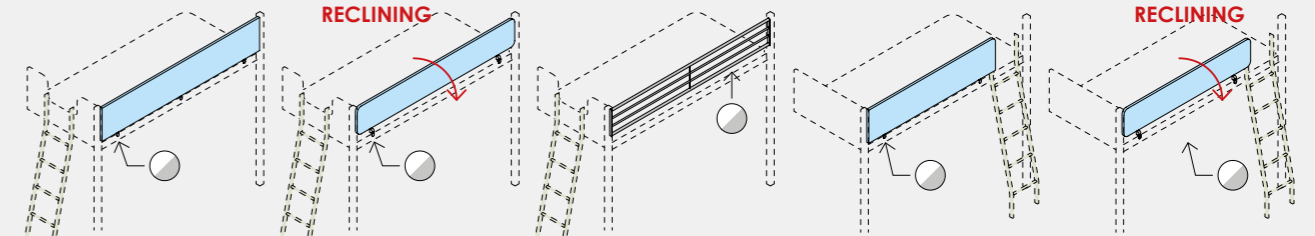

Code	PL58.50N	PL58.51U	PL58.52A	PL58.53G	PL58.54P
------	----------	----------	----------	----------	----------

Metal ladders

Ht	179,5	Side	Ht	179,5	Front
Dpt	34		Dpt	34	
W	30		W	30	

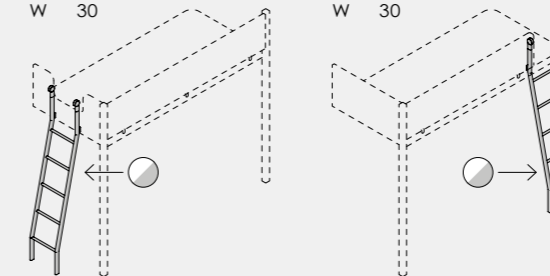

Code	PL58.55V	PL58.56B
Without light		
With light		

The ladder with light is provided with an element which supports a LED spotlight.

You can also use the DALIA and MARGOT ladders.

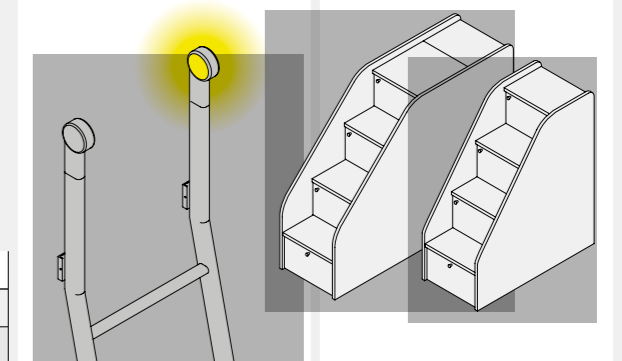

GROUP 1 colors	Rovere Dorian RD5T	Rovere white RW3Q	Noce naturale NN7H	Eucalipto CL1X	Domy DM7P	Bianco UV BU3Q
	Ciliegio bianco CB6K	Malta ML7H	Feltro FL8X	Cemento Masdar CM3Q	Blu indaco BI4B	
	Noce NC4B	Desert DS9L	Canapa CN1X	Moka MK6B	Cipria CP4J	
	Bianco opaco BI7A	Grigio Dorian GL4R	Basalto BS5T	Grigio titanio GZ8T	Rosa bubble RB7Y	
GROUP 2 colors	Agave GV7A	Verde Alpi VA5T	Cadaques CQ3Q	Giallo zafferano GZ8A	Corallo CR5T	
	Blu opale BO7H					
GROUP 3 colors						
CARCASE colors						

Space-saving systems

CLICK foldaway beds with W 80 base	330
CLICK foldaway beds with W 120 base	332
CLICK foldaway beds with W 140 base	333
CLICK foldaway beds with W 160 base - (A)	334
CLICK foldaway beds with W 160 base - (B)	338
CLICK tables	339
MULTIFUNCTION wheeled beds with W 80 base	340
MULTIFUNCTION wheeled beds with W 90 base	342
MUVI wheeled beds with W 80 base	344
GRETA container ladder with shaped sides	346
MULTIFUNCTION and MUVI bed guards	347
FLOTTA system	348

**Types and colors FRONT**

**ONE**  
matte  
glossy

**CLUB**

**WINDOW**

Rovere white RW3Q	Rovere Dorian RD5T	Ciliegio bianco CB6K	Noce naturale NN7H	Noce NC4B	Eucalipto CL1X	Malta ML7H
Feltro FL8X	Cemento Masdar CM3Q	Bianco opaco BI7A	Desert DS9L	Canapa CN1X	Moka MK6B	Grigio Dorian GL4R
Basalto BS5T	Grigio titanio GZ8T	Domy DM7P	Agave GV7A	Verde Alpi VA5T	Cadaques CQ3Q	Blu indaco BI4B
Blu opale BO7H	Cipria CP4J	Rosa bubble RB7Y	Giallo zafferano GZ8A	Corallo CR5T		
Bianco UV BU3Q						

**Specify the color of the CLUB handle**

Bianco opaco BI7A	Desert DS9L	Canapa CN1X	Moka MK6B	Grigio Dorian GL4R	Basalto BS5T	Grigio titanio GZ8T
Domy DM7P	Agave GV7A	Verde Alpi VA5T	Cadaques CQ3Q	Blu indaco BI4B	Blu opale BO7H	Cipria CP4J
Rosa bubble RB7Y	Giallo zafferano GZ8A	Corallo CR5T				

**Specify the color of the aluminum frame**

Trasparente TR9M	Trasparente fumé FT8P	Stop-sol ST6P	Specchio SP7L
Alluminio AL1A	Titan grey TG7H		

All measurements are expressed in centimeters; with tolerance ± 2 cm for upholstered items.

# CLICK foldaway beds with W 80 base

The save space CLICK must be fixed to the wall with the supplied hardware. Wall anchors are not included; the choice of the type of anchor to be used must be made by the fitter based on the characteristics of the wall.

## Single bed

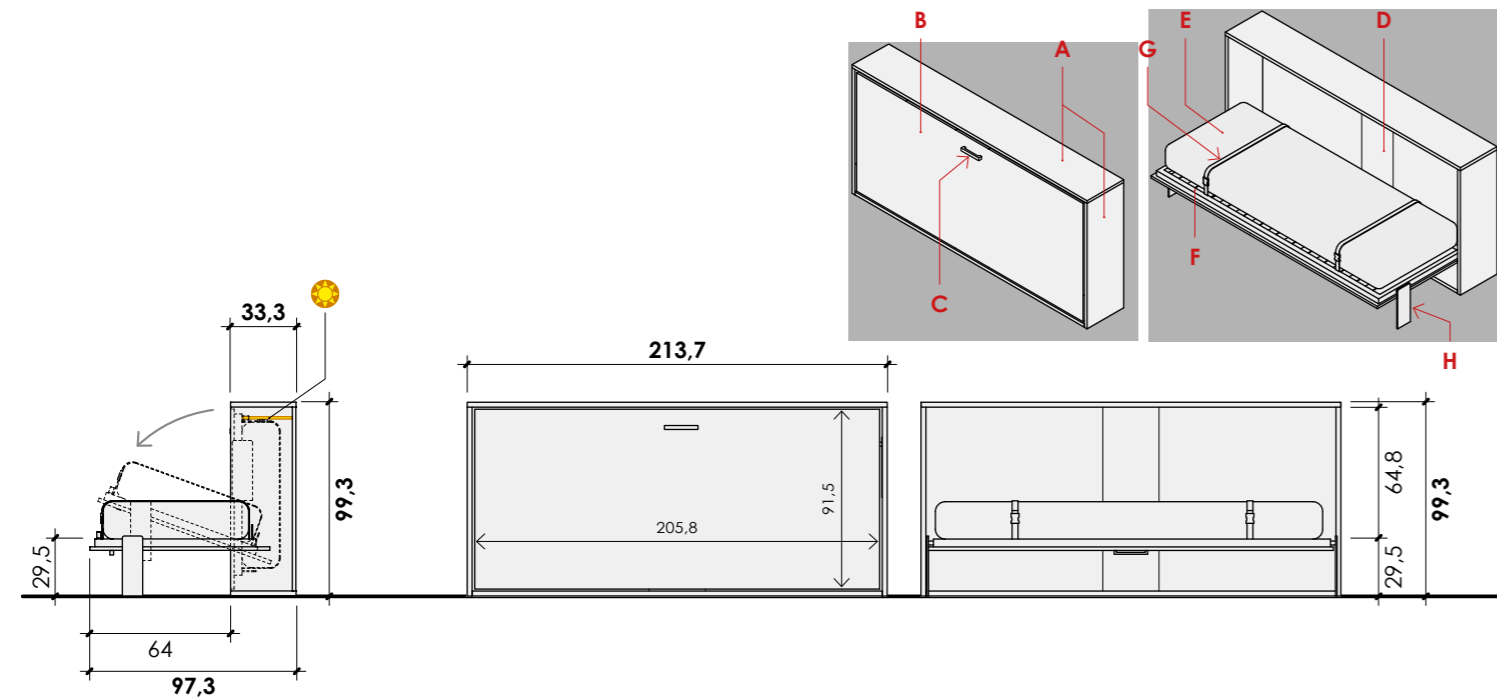

## Single bed on bookcase

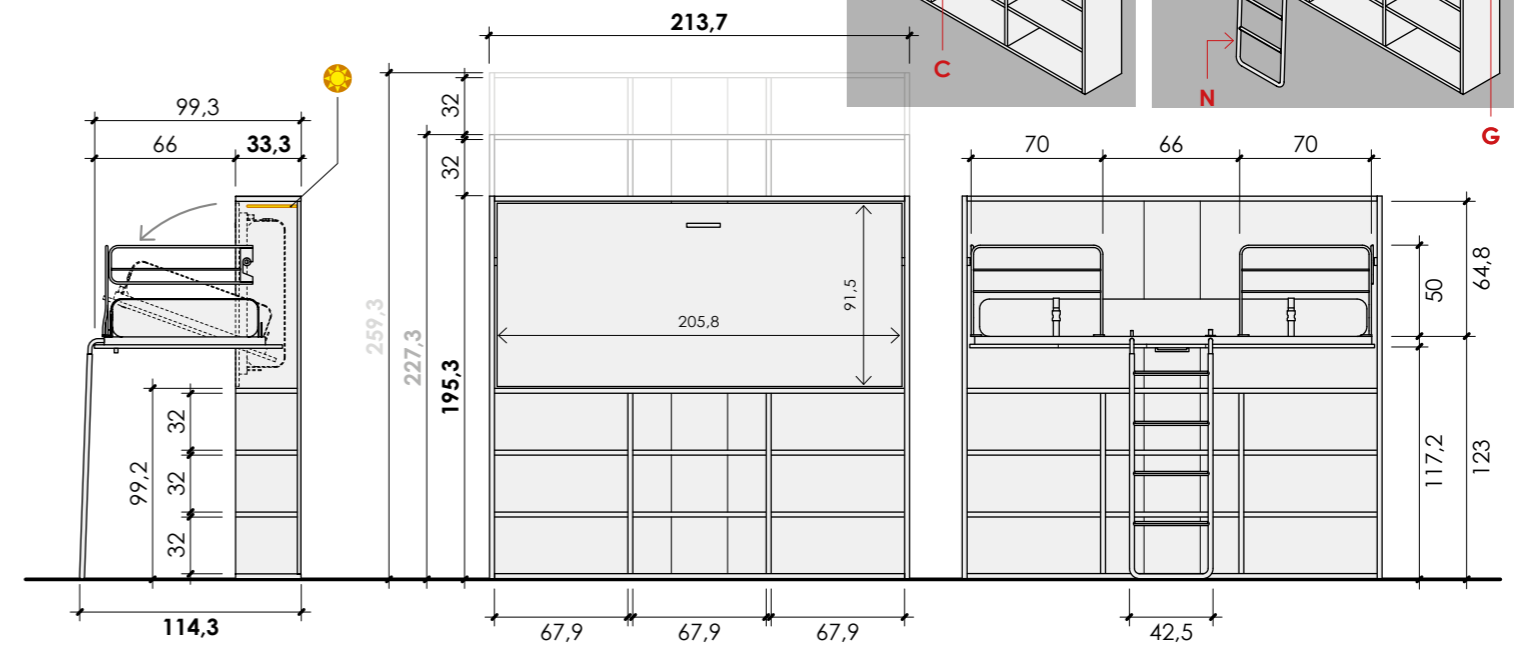

### Single bed

W 213,7  
Ht 99,3

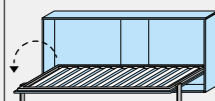

Code **PK43.04K**

Use the:  
mattress 200 x 80

Without light

With light Specify R or L

### Single beds on bookcase

W 213,7  
Ht 195,3

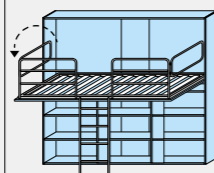

Code **PK43.05R**

Ht 227,3

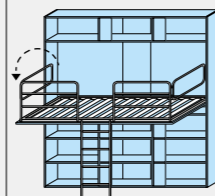

Code **PK43.06X**

Ht 259,3

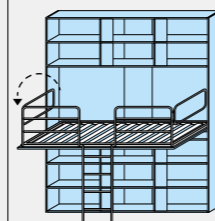

Code **PK43.07D**

### 2 single beds

W 213,7  
Ht 195,3

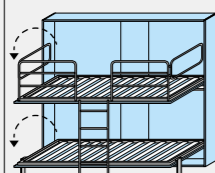

Code **PK43.08L**

Use the:  
mattress 200 x 80

Without light

With light Specify R or L

Ht 227,3

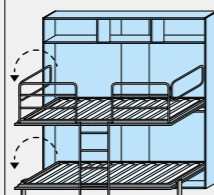

Code **PK43.09S**

Ht 259,3

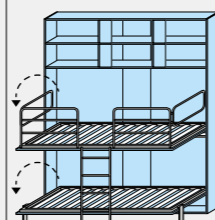

Code **PK43.10P**

## 2 single beds

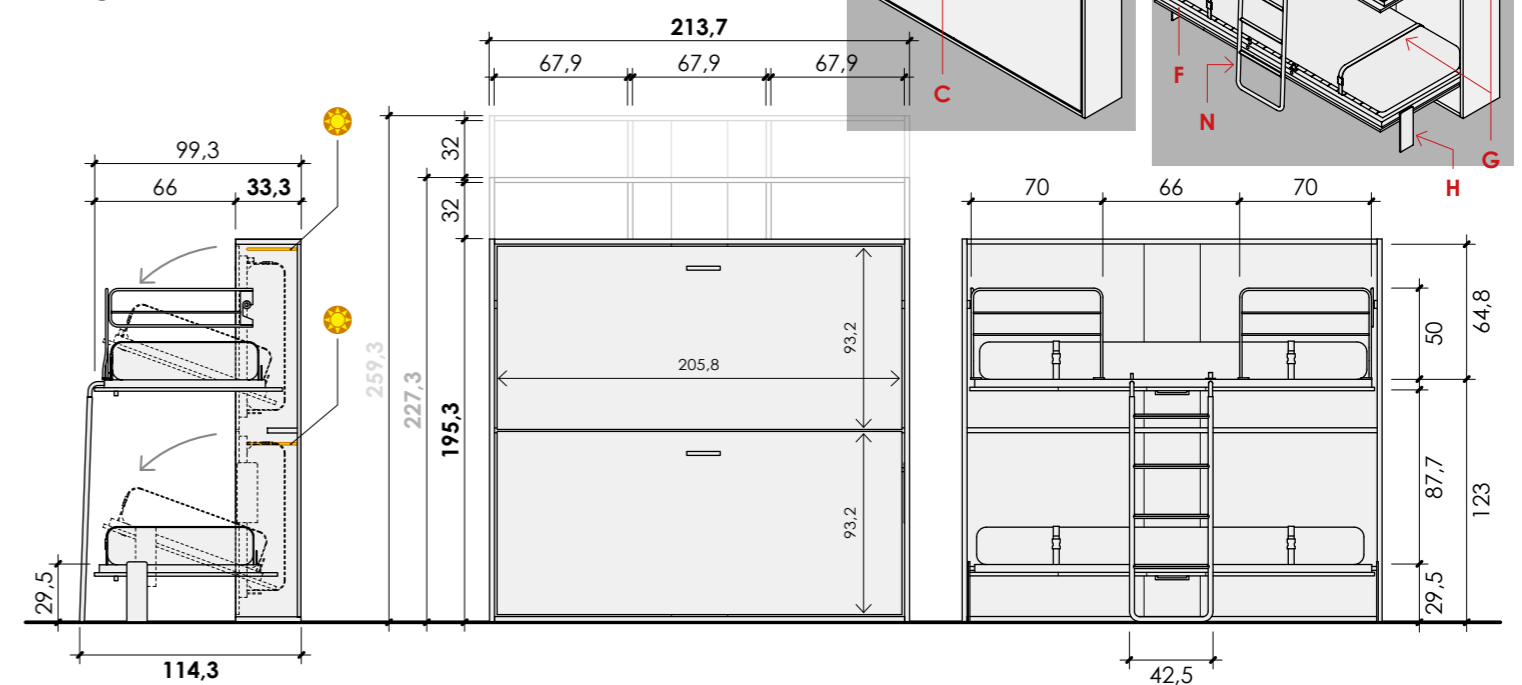

Components in **GROUP 2** colors

- A Structure Th 2.5
- B Front panels Th 1.8
- C Horizontal handle, to be chosen among those 160 mm pitch (MIRA G88N excluded)
- D Backboard Th 1.8
- E Mattress
- F Slatted base
- G Mattress clips
- H Fold-down feet
- I Feet/shelf
- L Padded headboard (optional)
- M Fold-down metal protection
- N Removable metal ladder
- O Sofa
- P Feet/desk top
- Q Tipper table with metallic structure in Champagne color
- R Anti tipping lock

### Led lighting

The space save beds can be fitted with an internal light on the side (flush-fit), inserted into a dedicated slot. It has a built-in touch switch and transformer (12V 10W).

- Single beds with bed base W 80 can be equipped with 1 light (specify R or L).
- The two single beds with bed base W 80 can be equipped with 2 lights, for the top and bottom bed, both on the same side (specify R or L).

Mattresses, pillows and slatted bed base  
See back cover wing





# CLICK foldaway beds with W 120 base

The save space CLICK must be fixed to the wall with the supplied hardware. Wall anchors are not included; the choice of the type of anchor to be used must be made by the fitter based on the characteristics of the wall.

## Single bed + writing desk Dpt 50

The front panels consist of adjacent panels in different sizes. The position of the panels is fixed (as shown). The colour of the panels can be customised to customer's choice.

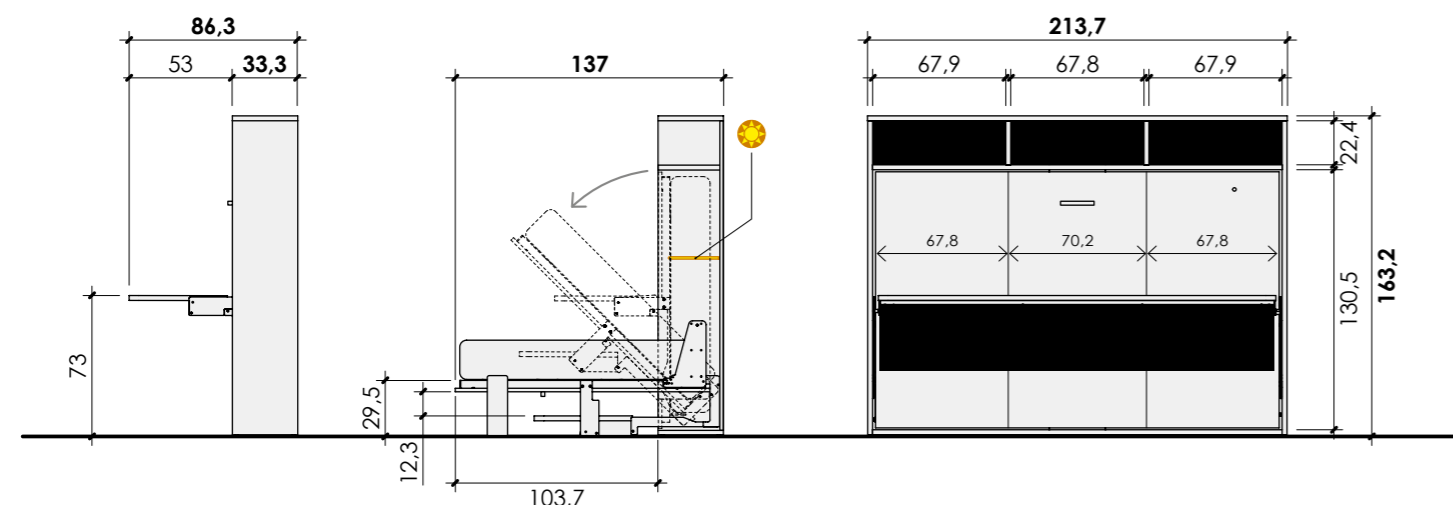
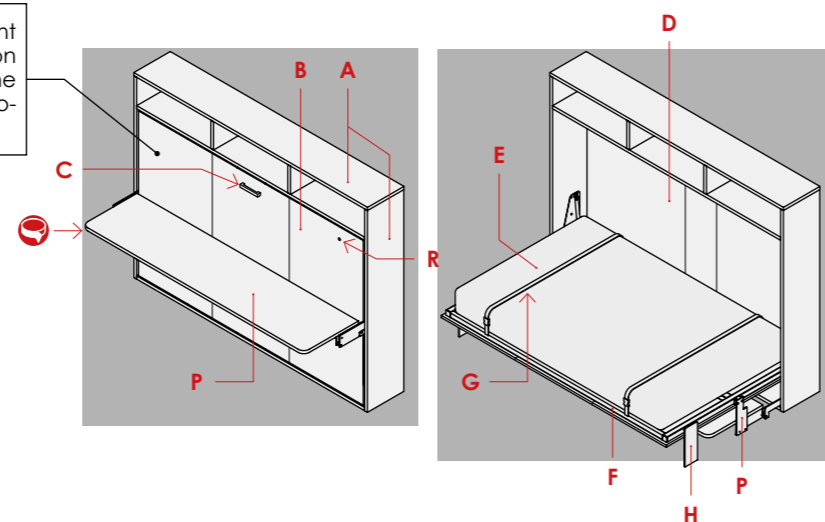

### Single bed + writing desk Dpt 50

W 213,7  
Ht 163,2

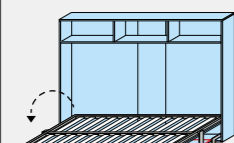

Use the: mattress 200 x 120

<b>Code</b>	PK43.11V		
Without light			
With light	Specify R or L		

Components in **GROUP 2 colors**

FABRIC JENNY	0402	0403	0503	0900	0903	0905	0314	0303	0805	0706	0704	0601	0604
FABRIC KENYA	0014	0013	0016	0020	0019								
FALUX LEATHER TAPE	0111	0102	0603	0415	0605	0700	0608	0901					

Shaped components available with contrasting edging.

- A Structure Th 2.5
- B Front panels Th 1.8
- C Horizontal handle, to be chosen among those 160 mm pitch (MIRA G88N excluded)
- D Backboard Th 1.8
- E Mattress
- F Slatted base
- G Mattress clips
- H Fold-down feet
- I Feet/shelf
- L Padded headboard (optional)
- M Fold-down metal protection
- N Removable metal ladder
- O Sofa
- P Feet/desk top
- Q Tipper table with metallic structure in Champagne color
- R Anti tipping lock

# CLICK foldaway beds with W 140 base

The save space CLICK must be fixed to the wall with the supplied hardware. Wall anchors are not included; the choice of the type of anchor to be used must be made by the fitter based on the characteristics of the wall.

## Single bed

## Single bed + shelf Dpt 26

The front panels consist of adjacent panels in different sizes. The position of the panels is fixed (as shown). The colour of the panels can be customised to customer's choice.

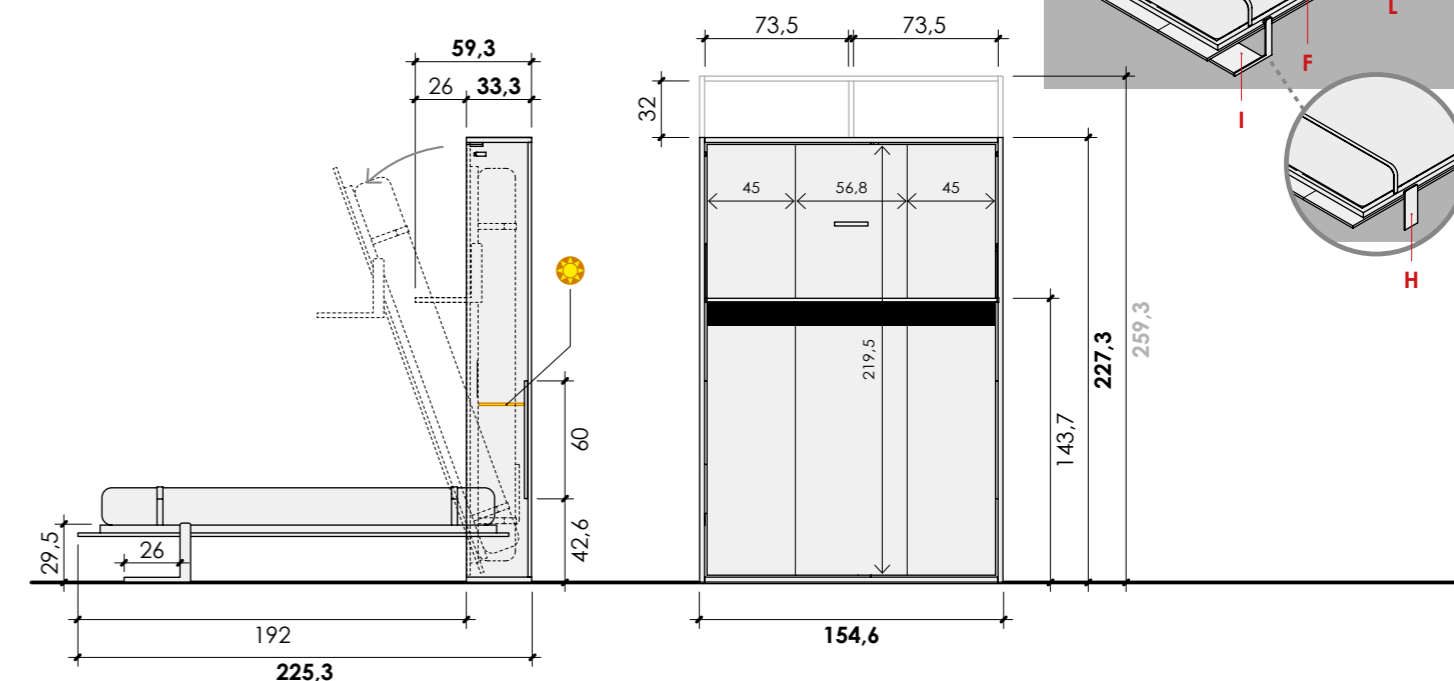
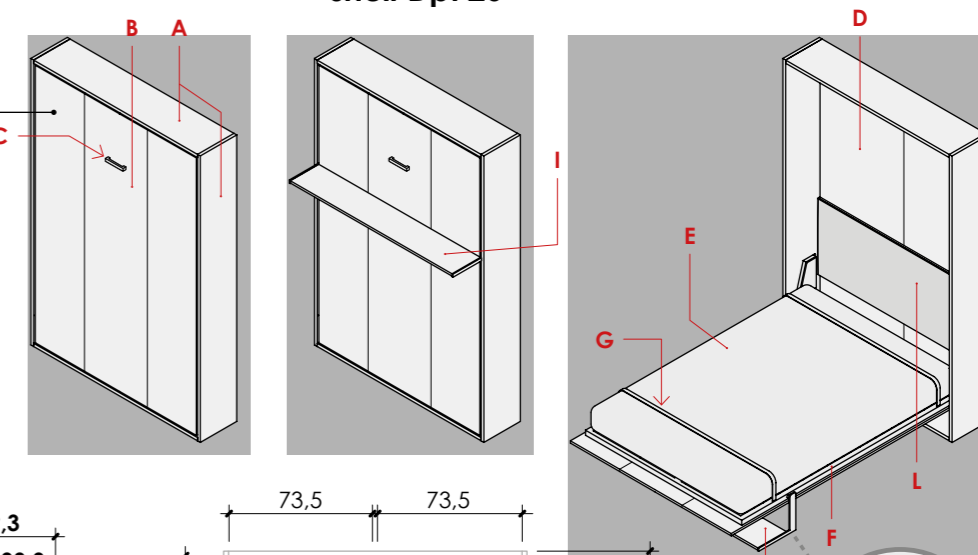

### Single beds

W 154,6  
Ht 227,3

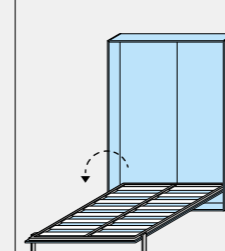

**Code** PK43.12B

### Single beds + shelf Dpt 26

W 154,6  
Ht 259,3

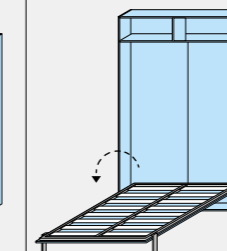

**Code** PK43.13H

### Single beds + shelf Dpt 26

W 154,6  
Ht 227,3

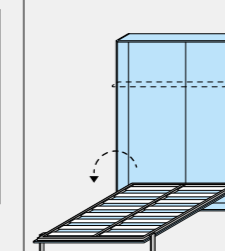

**Code** PK43.14Q

### Single beds + shelf Dpt 26

W 154,6  
Ht 259,3

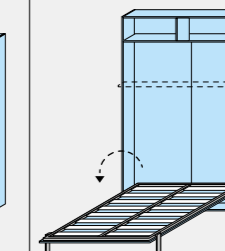

**Code** PK43.15W

### Padded headboard

Ht 60  
Th 2,5

Only with H 17 mattresses

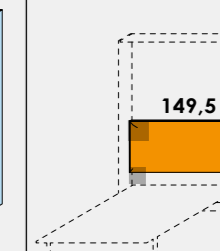

**Code** PL87.49W

Use the: mattress 200 x 140

<b>Code</b>	PK43.12B	PK43.13H	PK43.14Q	PK43.15W	PL87.49W
Without light					
With light					

### Led lighting

The space save beds can be fitted with an internal light on the side (flush-fit), inserted into a dedicated slot. It has a built-in touch switch and transformer (12V 10W).

- Single beds with bed base W 120 can be equipped with 1 light (specify R or L).
- The single beds with bed base W 140 can be equipped with 2 lights, always on both sides.

Mattresses, pillows and slatted bed base  
See back cover wing



# CLICK foldaway beds with W 160 base - (A)

The save space CLICK must be fixed to the wall with the supplied hardware. Wall anchors are not included; the choice of the type of anchor to be used must be made by the fitter based on the characteristics of the wall.

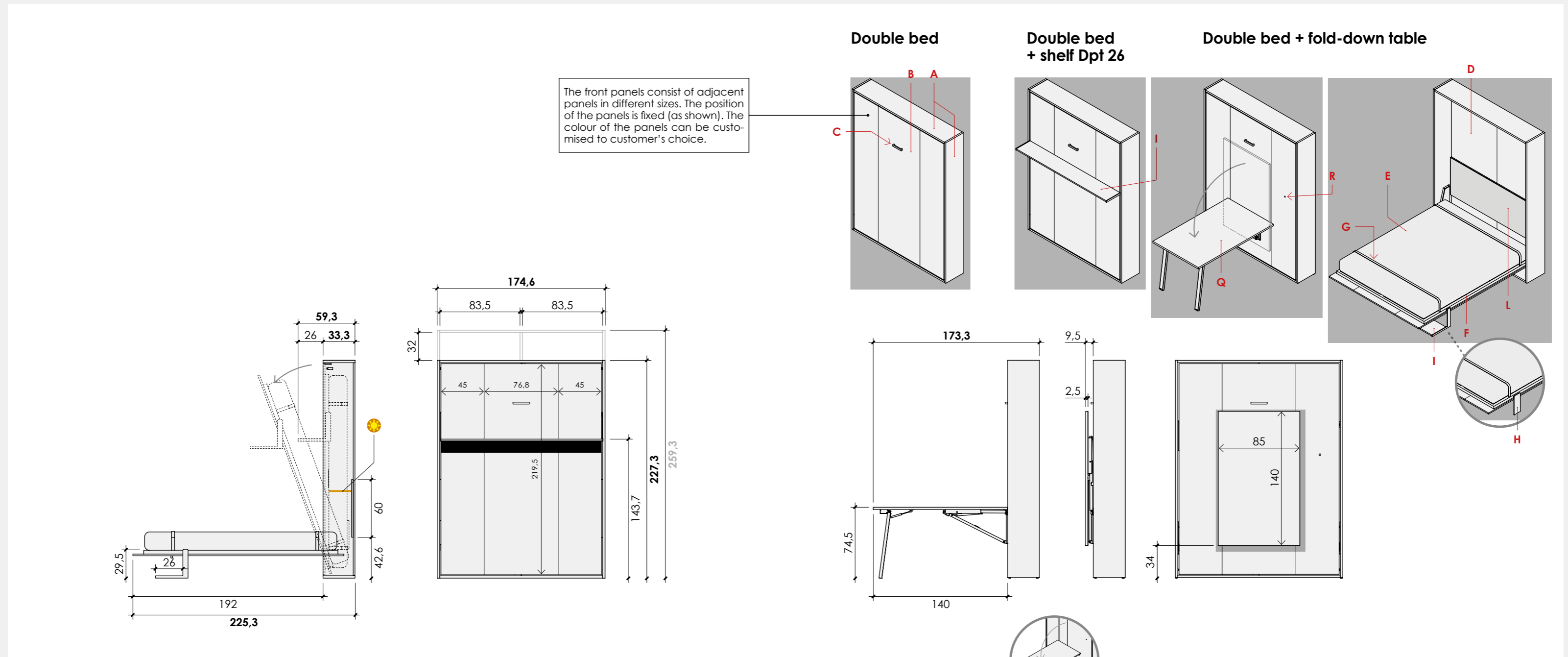

The front panels consist of adjacent panels in different sizes. The position of the panels is fixed (as shown). The colour of the panels can be customised to customer's choice.

### Double beds

W 174,6  
Ht 227,3

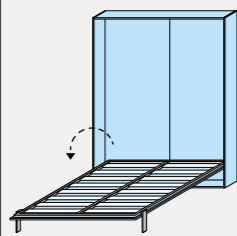

Code PK43.16C

Ht 259,3

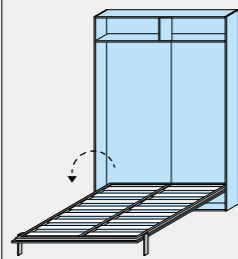

Code PK43.17K

### Double beds + shelf Dpt 26

W 174,6  
Ht 227,3

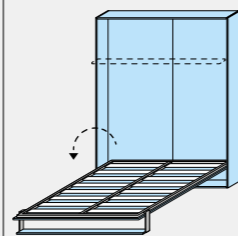

Code PK43.18R

Ht 259,3

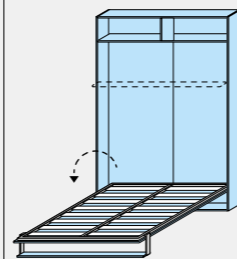

Code PK43.19X

### Double beds + fold-down table

W 174,6  
Ht 227,3

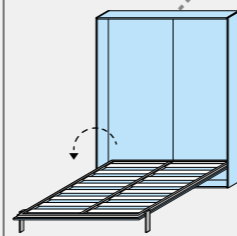

Code PK43.20V

Ht 259,3

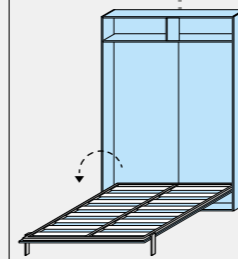

Code PK43.21A

### Padded headboard

Only with H 17 mattresses

Ht 60  
Th 2,5

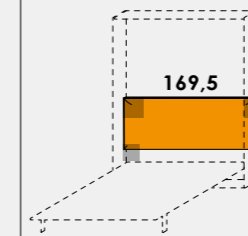

Code PL86.45R

Use the:  
mattress 200 x 160

Code  
Without light  
With light

Components in GROUP 2 colors

FABRIC JENNY	0402	0403	0503	0900	0903	0905	0314	0303	0805	0706	0704	0601	0604
FABRIC KENYA	0014	0013	0016	0020	0019								
FALIX LEATHER TAPE	0111	0102	0603	0415	0503	0605	0700	0608	0901				

- A Structure Th 2.5
- B Front panels Th 1.8
- C Horizontal handle, to be chosen among those 160 mm pitch (MIRA G88N excluded)
- D Backboard Th 1.8
- E Mattress
- F Slatted base
- G Mattress clips
- H Fold-down feet
- I Feet/shelf
- L Padded headboard (optional)
- M Fold-down metal protection
- N Removable metal ladder
- O Sofa
- P Feet/desk top
- Q Tipper table with metallic structure in Champagne color
- R Anti tipping lock

### Led lighting

The space save beds can be fitted with an internal light on the side (flush-fit), inserted into a dedicated slot. It has a built-in touch switch and transformer (12V 10W).

- Double beds (A) can be equipped with 2 lights, always on both sides.

Mattresses, pillows and slatted bed base  
See back cover wing



# CLICK foldaway beds with W 160 base - (A)

The save space CLICK must be fixed to the wall with the supplied hardware. Wall anchors are not included; the choice of the type of anchor to be used must be made by the fitter based on the characteristics of the wall.

## Double bed + sofa

Sofa with removable covers

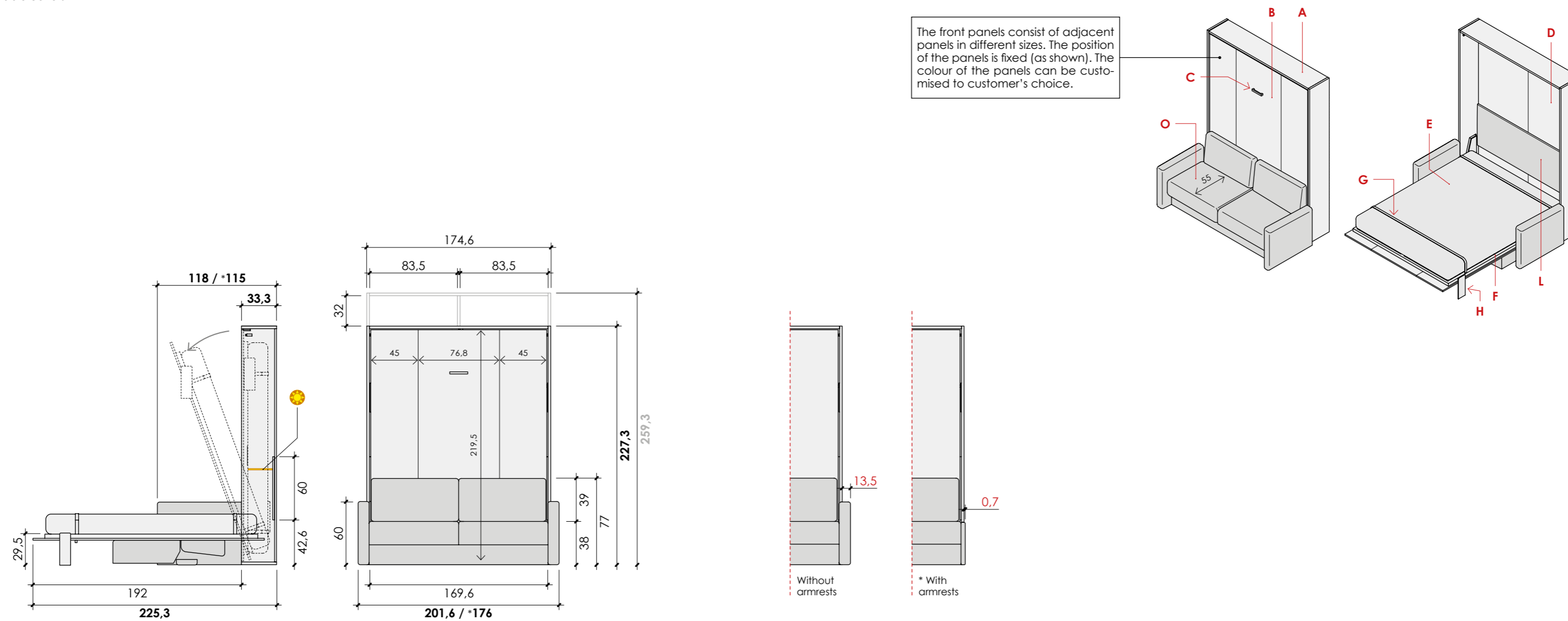

	Without armrests		With 2 armrests		With 1 armrest Specify armrest R or L (drawing shows L)		Padded headboard Only with H 17 mattresses	Pouf
	W 176	Ht 227,3	W 201,6	Ht 227,3	W 188,8	Ht 227,3	Ht 60 Th 2,5	With removable covers Dpt 60 W 60 Ht 38
	174,6	174,6	174,6	174,6	174,6	174,6	169,5	
<b>Code</b>	PK43.22G	PK43.23P	PK43.24V	PK43.25B	PK43.26H	PK43.27Q	PL86.45R	PL86.19A
Without light								
With light								

Use the:  
mattress 200 x 160

Components in **GROUP 2 colors**

FABRIC JENNY	0402	0403	0503	0900	0903	0905	0314	0303	0805	0706	0704	0601	0604
FABRIC KENYA	0014	0013	0016	0020	0019								
FALIX LEATHER	0111	0102	0603	0415	0503	0605	0700	0608	0901				
TAPE													

- A Structure Th 2.5
- B Front panels Th 1.8
- C Horizontal handle, to be chosen among those 160 mm pitch (MIRA G88N excluded)
- D Backboard Th 1.8
- E Mattress
- F Slatted base
- G Mattress clips
- H Fold-down feet
- I Feet/shelf
- L Padded headboard (optional)
- M Fold-down metal protection
- N Removable metal ladder
- O Sofa
- P Feet/desk top
- Q Tipper table with metallic structure in Champagne color
- R Anti tipping lock

### Led lighting

The space save beds can be fitted with an internal light on the side (flush-fit), inserted into a dedicated slot. It has a built-in touch switch and transformer (12V 10W).

- Double beds (A) can be equipped with 2 lights, always on both sides.



# CLICK foldaway beds with W 160 base - (B)

The save space CLICK must be fixed to the wall with the supplied hardware. Wall anchors are not included; the choice of the type of anchor to be used must be made by the fitter based on the characteristics of the wall.

## Double bed

The front panels consist of adjacent panels in different sizes. The position of the panels is fixed (as shown). The colour of the panels can be customised to customer's choice.

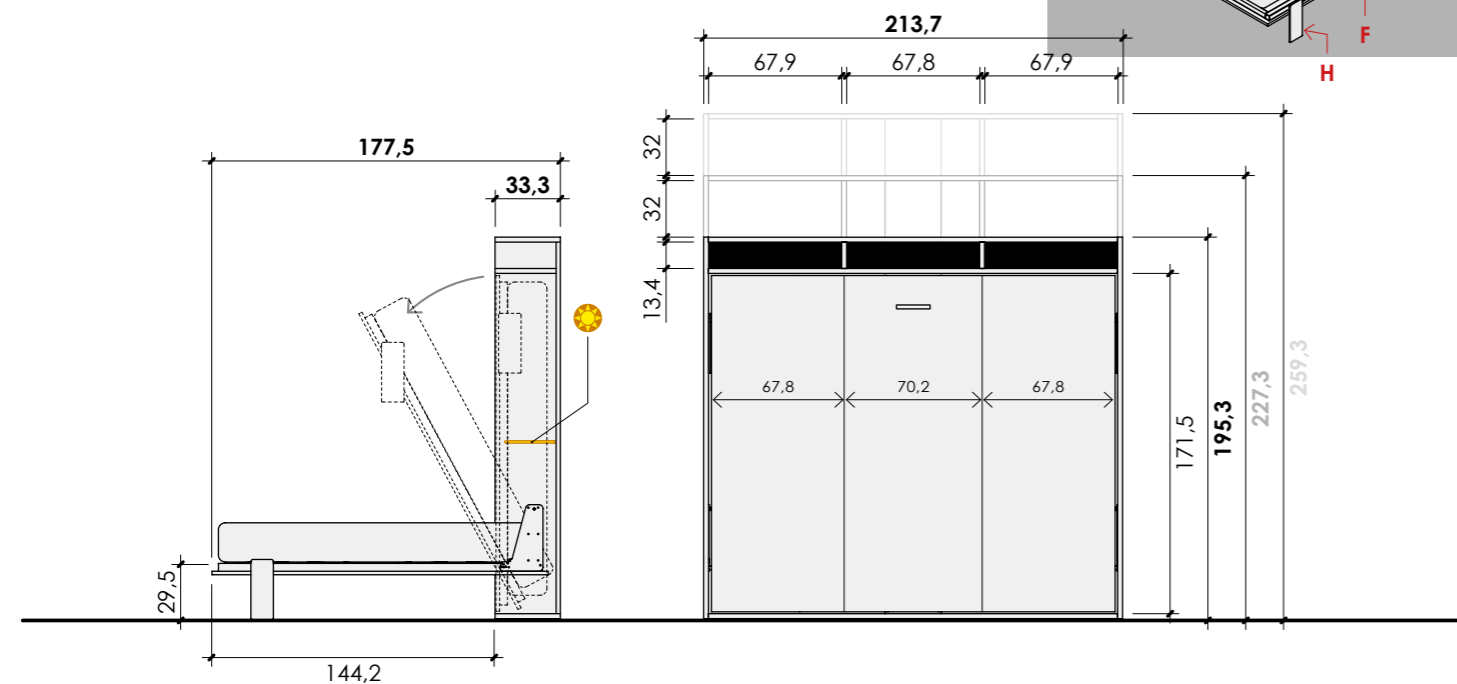
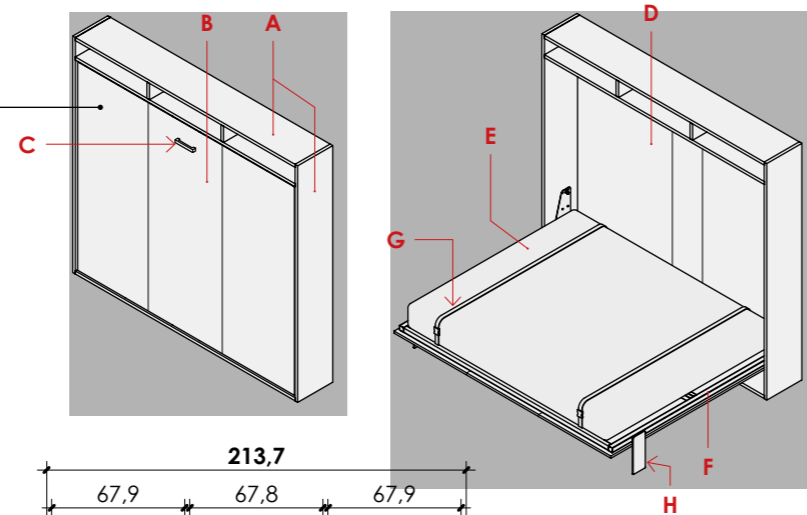

### Double beds

W 213,7  
Ht 195,3

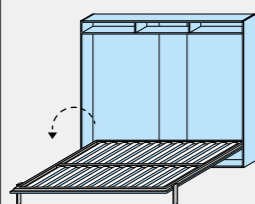

Code PK43.28W

Ht 227,3

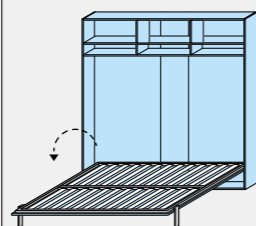

Code PK43.29C

Ht 259,3

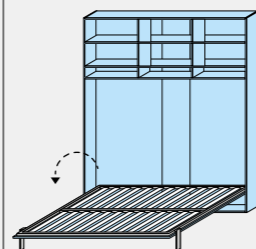

Code PK43.30Z

Use the:  
mattress 200 x 160

Code  
Without light  
With light Specify R or L

Components in GROUP 2 colors  
Components in Types and colors FRONT

- A Structure Th 2.5
- B Front panels Th 1.8
- C Horizontal handle, to be chosen among those 160 mm pitch (MIRA G88N excluded)
- D Backboard Th 1.8
- E Mattress
- F Slatted base
- G Mattress clips
- H Fold-down feet
- I Feet/shelf
- L Padded headboard (optional)
- M Fold-down metal protection
- N Removable metal ladder
- O Sofa
- P Feet/desk top
- Q Tipper table with metallic structure in Champagne color
- R Anti tipping lock

# CLICK tables

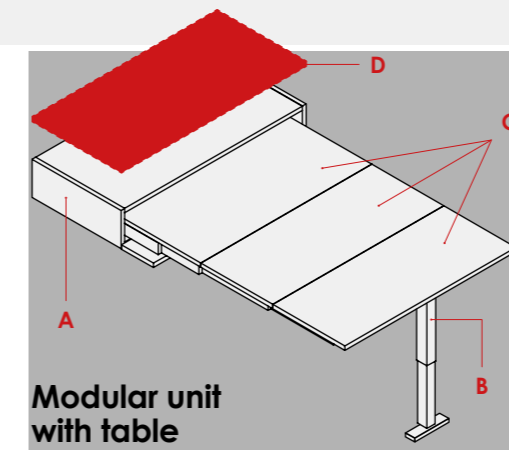

## Modular unit with table

- A Modular carcass Th 1.8.
- B Fold-down metal support for pull-out table.
- C Pull-out table top, Th 1.8.
- D It is advisable to complete every composition with the Top (see section Modular units).

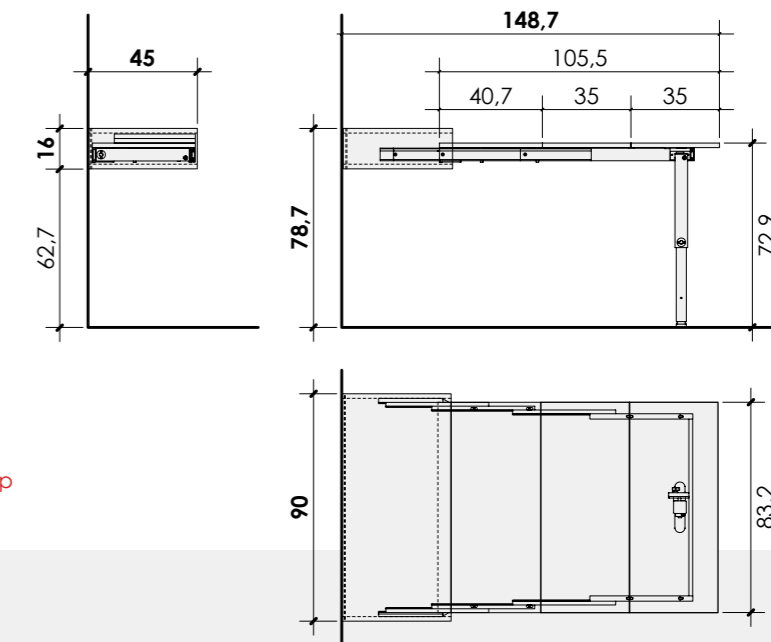

Code	PL86.46X			
ONE	matte			
	glossy			
CLUB				

## Wall tipper table

Plan Th 2.5  
Metallic structure in Champagne color.

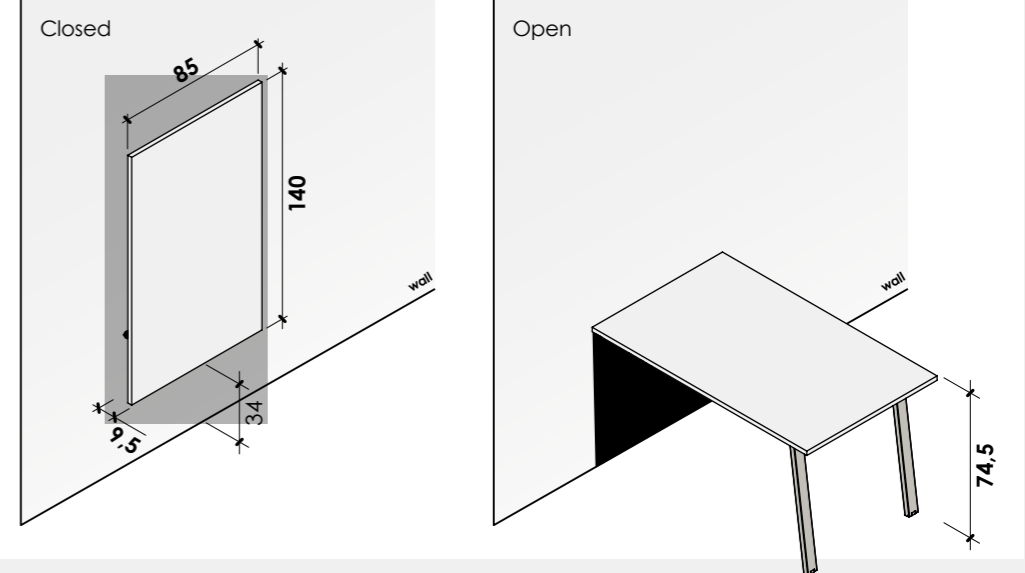

Code	PK43.03C			
------	----------	--	--	--

- OPTIONAL:** p. 614
- A - Extra colors for Top panel and Bottom panel (For Modular unit Ht 16 Dpt 45 W 90)
- B - Extra colors for Side panels (For Modular unit Ht 16 Dpt 45 W 90)

**Led lighting** ☀️  
The space save beds can be fitted with an internal light on the side (flush-fit), inserted into a dedicated slot. It has a built-in touch switch and transformer (12V 10W).

• Double beds (B) can be equipped with 1 light (specify R or L).



**p. 56** Knob and handle positions  
**p. 662** Tops and Bases for Modular units and Wall units

# MULTIFUNCTION wheeled beds with W 80 base

## Upper beds - Structural base W 83 Dpt 203

Use the: mattress 200 x 80

### ATTREZZATO

Inside bed space 203 x 83  
Structural slatted bed base included.  
With 2 pull-out desks (up to 55 cm) and 2 drawers.

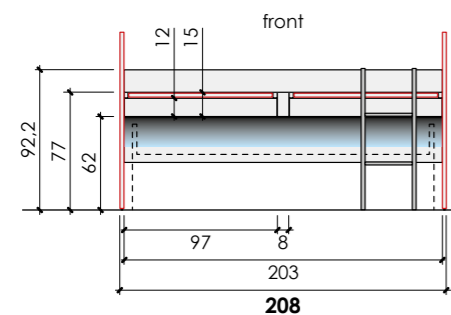

### GIANO

Ht 118  
Dpt 208  
W 92

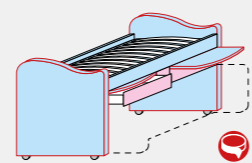

<b>Code</b>	<b>PL51.13E</b>
ONE	matte
	glossy
CLUB	

### POLDO

Ht 118  
Dpt 208  
W 92

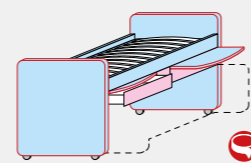

<b>Code</b>	<b>PL51.14M</b>
ONE	
CLUB	

### LOVE

Ht 120  
Dpt 208  
W 92

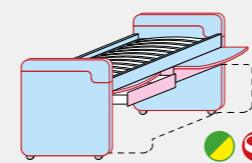

<b>Code</b>	<b>PL51.15T</b>
ONE	
CLUB	

### ALTO

Inside bed space 203 x 83  
Structural slatted bed base included.

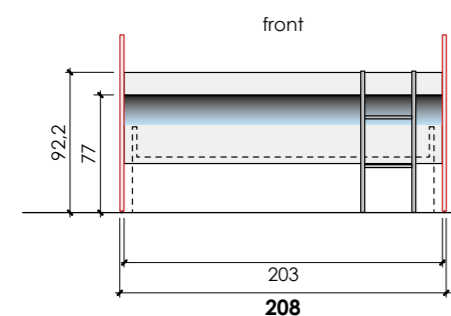

### GIANO

Ht 118  
Dpt 208  
W 92

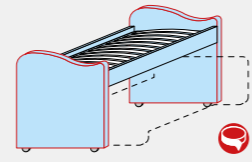

<b>Code</b>	<b>PL51.16Z</b>
ONE	
CLUB	

### POLDO

Ht 118  
Dpt 208  
W 92

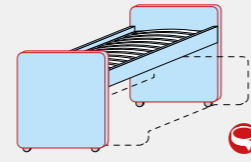

<b>Code</b>	<b>PL51.17F</b>
ONE	
CLUB	

### LOVE

Ht 120  
Dpt 208  
W 92

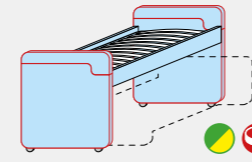

<b>Code</b>	<b>PL51.18N</b>
ONE	
CLUB	

### BASSO

Inside bed space 203 x 83  
Structural slatted bed base included.

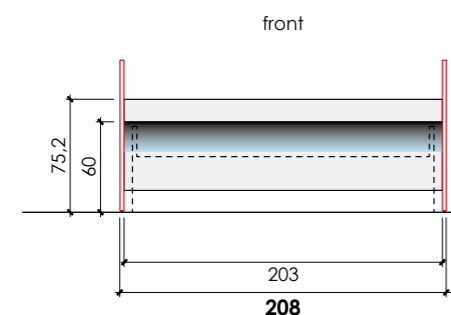

### GIANO

Ht 101  
Dpt 208  
W 92

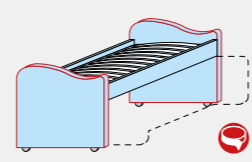

<b>Code</b>	<b>PL51.19U</b>
ONE	
CLUB	

### POLDO

Ht 101  
Dpt 208  
W 92

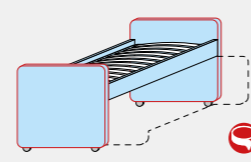

<b>Code</b>	<b>PL51.20R</b>
ONE	
CLUB	

### LOVE

Ht 103  
Dpt 208  
W 92

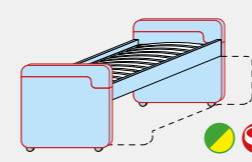

<b>Code</b>	<b>PL51.21X</b>
ONE	
CLUB	

## Lower beds - Base W 80

Use the: mattress 190 x 80

Fitted with large drawers and slatted base

### GIANO

Ht 57  
Dpt 200  
W 89

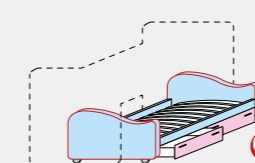

<b>Code</b>	<b>PL51.22D</b>
ONE	
CLUB	

### POLDO

Ht 57  
Dpt 200  
W 89

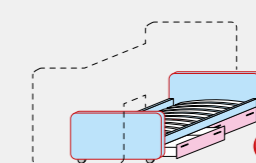

<b>Code</b>	<b>PL51.23L</b>
ONE	
CLUB	

### LOVE

Ht 57  
Dpt 200  
W 89

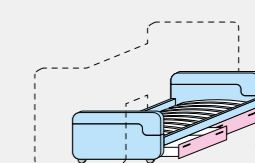

<b>Code</b>	<b>PL51.24S</b>
ONE	
CLUB	

Fitted with 2<sup>nd</sup> base W 80 and slatted base

### GIANO

Ht 57  
Dpt 200  
W 89

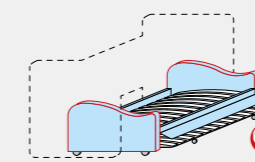

<b>Code</b>	<b>PL51.25Y</b>
ONE	
CLUB	

### POLDO

Ht 57  
Dpt 200  
W 89

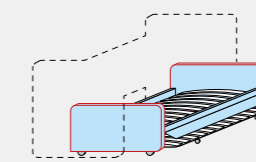

<b>Code</b>	<b>PL51.26E</b>
ONE	
CLUB	

### LOVE

Ht 57  
Dpt 200  
W 89

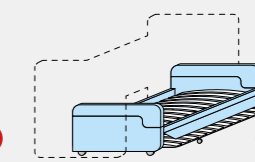

<b>Code</b>	<b>PL51.27M</b>
ONE	
CLUB	

Without base  
Internal dimensions 193 x 81

### GIANO

Ht 57  
Dpt 200  
W 89

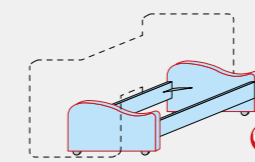

<b>Code</b>	<b>PL51.28T</b>
ONE	
CLUB	

### POLDO

Ht 57  
Dpt 200  
W 89

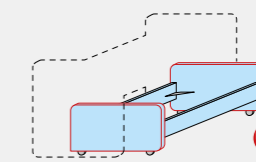

<b>Code</b>	<b>PL51.29Z</b>
ONE	
CLUB	

### LOVE

Ht 57  
Dpt 200  
W 89

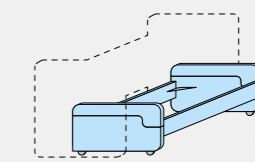

<b>Code</b>	<b>PL51.30W</b>
ONE	
CLUB	

- Built in self-braking casters.
- We recommend using at least 1 safety guard.
- With high beds we recommend using the ladder.
- Elements can not be modified.
- Lower compartment Dpt 89.
- The large drawers of the bottom elements are fixed with runners.

Example: GIANO beds

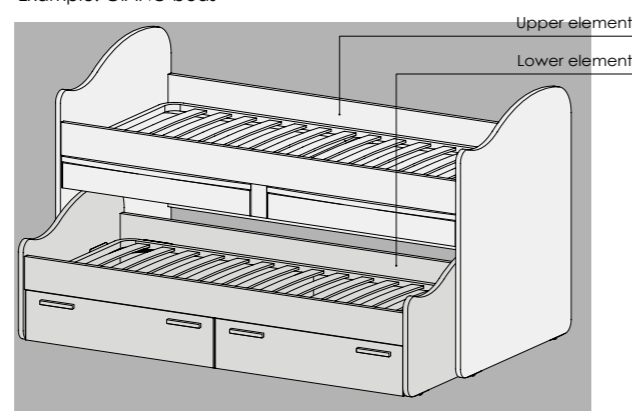

Metal ladder with fixing  
NOT on top bed BASSO  
Ht 96.4 - W 32.5

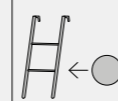

<b>Code</b>	<b>PL44.92B</b>
-------------	-----------------

Metal bed frame  
Dpt 193 - Ht 29

With 4 castor wheels with brake  
W 88

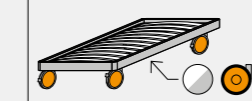

<b>Code</b>	<b>P51.89N</b>
-------------	----------------

Somier  
Dpt 200 - Ht 29

With 4 castor wheels with brake  
W 88

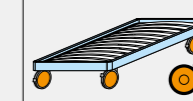

<b>Code</b>	<b>P51.86W</b>
-------------	----------------

- Components in **GROUP 2 colors**
- Components in **Types and colors FRONT**
- Shaped components available with contrasting edging.
- Is available in two colors.

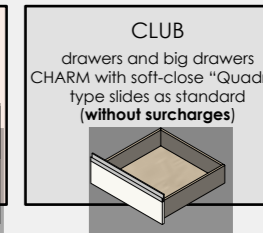
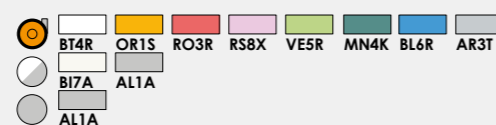

# MULTIFUNCTION wheeled beds with W 90 base

## Upper beds - Structural base W 93 Dpt 203

Use the: mattress 200 x 90

### ATTREZZATO

Inside bed space 203 x 93  
Structural slatted bed base included.  
With 2 pull-out desks (up to 55 cm) and 2 drawers.

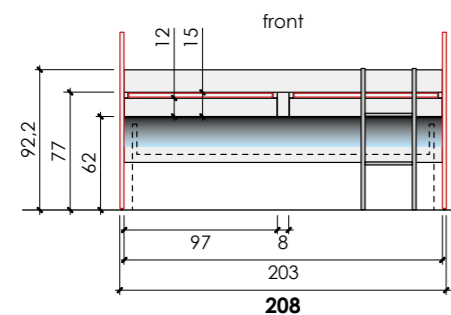

### GIANO

Ht 118  
Dpt 208  
W 102

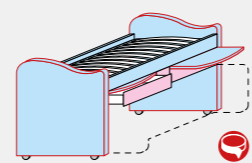

<b>Code</b>	<b>PL51.31C</b>
ONE	matte glossy
CLUB	

### POLDO

Ht 118  
Dpt 208  
W 102

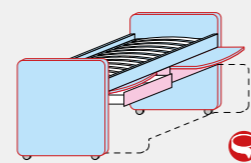

<b>Code</b>	<b>PL51.32K</b>
ONE	
CLUB	

### LOVE

Ht 120  
Dpt 208  
W 102

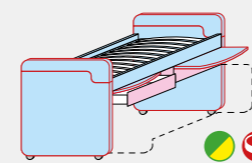

<b>Code</b>	<b>PL51.33R</b>
ONE	
CLUB	

### ALTO

Inside bed space 203 x 93  
Structural slatted bed base included.

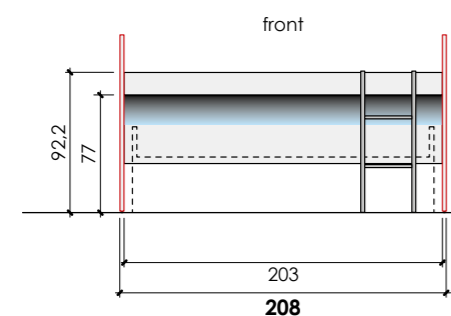

### GIANO

Ht 118  
Dpt 208  
W 102

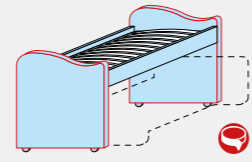

<b>Code</b>	<b>PL51.34X</b>
ONE	
CLUB	

### POLDO

Ht 118  
Dpt 208  
W 102

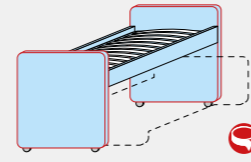

<b>Code</b>	<b>PL51.35D</b>
ONE	
CLUB	

### LOVE

Ht 120  
Dpt 208  
W 102

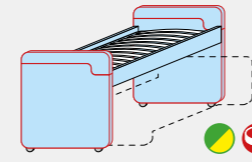

<b>Code</b>	<b>PL51.36L</b>
ONE	
CLUB	

### BASSO

Inside bed space 203 x 93  
Structural slatted bed base included.

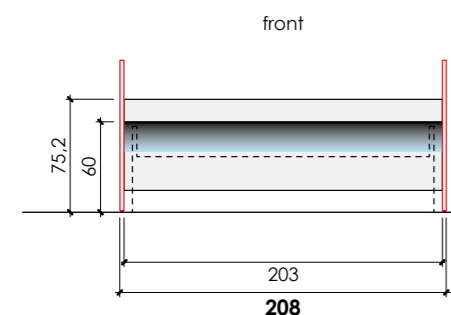

### GIANO

Ht 101  
Dpt 208  
W 102

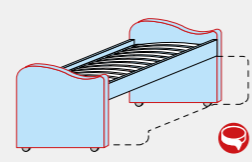

<b>Code</b>	<b>PL51.37S</b>
ONE	
CLUB	

### POLDO

Ht 101  
Dpt 208  
W 102

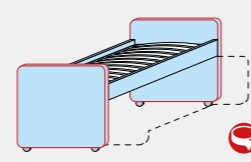

<b>Code</b>	<b>PL51.38Y</b>
ONE	
CLUB	

### LOVE

Ht 103  
Dpt 208  
W 102

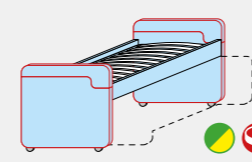

<b>Code</b>	<b>PL51.39E</b>
ONE	
CLUB	

## Lower beds - Base W 90

Use the: mattress 190 x 90  
(for pull-out base 190 x 80)

Fitted with large drawers and slatted base

### GIANO

Ht 57  
Dpt 200  
W 99

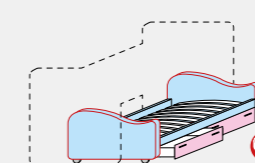

<b>Code</b>	<b>PL51.40B</b>
ONE	matte glossy
CLUB	

### POLDO

Ht 57  
Dpt 200  
W 99

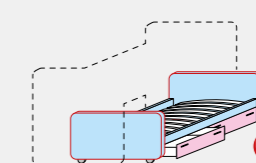

<b>Code</b>	<b>PL51.41H</b>
ONE	
CLUB	

### LOVE

Ht 57  
Dpt 200  
W 99

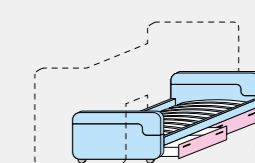

<b>Code</b>	<b>PL51.42Q</b>
ONE	
CLUB	

Fitted with 2<sup>nd</sup> base W 80 and slatted base

### GIANO

Ht 57  
Dpt 200  
W 99

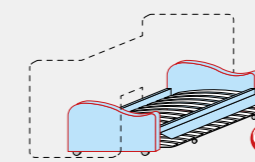

<b>Code</b>	<b>PL51.43W</b>
ONE	
CLUB	

### POLDO

Ht 57  
Dpt 200  
W 99

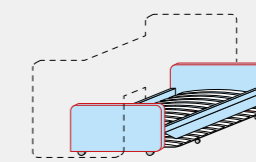

<b>Code</b>	<b>PL51.44C</b>
ONE	
CLUB	

### LOVE

Ht 57  
Dpt 200  
W 99

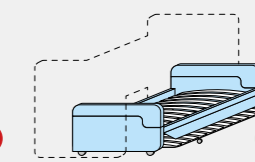

<b>Code</b>	<b>PL51.45K</b>
ONE	
CLUB	

Without base

Internal dimensions 193 x 91

### GIANO

Ht 57  
Dpt 200  
W 99

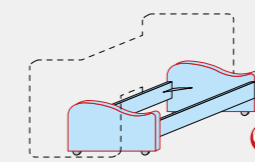

<b>Code</b>	<b>PL51.46R</b>
ONE	
CLUB	

### POLDO

Ht 57  
Dpt 200  
W 99

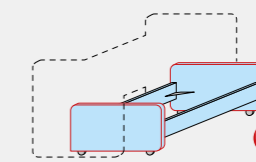

<b>Code</b>	<b>PL51.47X</b>
ONE	
CLUB	

### LOVE

Ht 57  
Dpt 200  
W 99

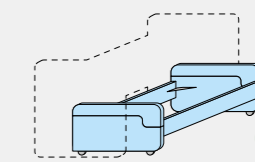

<b>Code</b>	<b>PL51.48D</b>
ONE	
CLUB	

- Built in self-braking casters.
- We recommend using at least 1 safety guard.
- With high beds we recommend using the ladder.
- Elements can not be modified.
- Lower compartment Dpt 99.
- The large drawers of the bottom elements are fixed with runners.

Example: GIANO beds

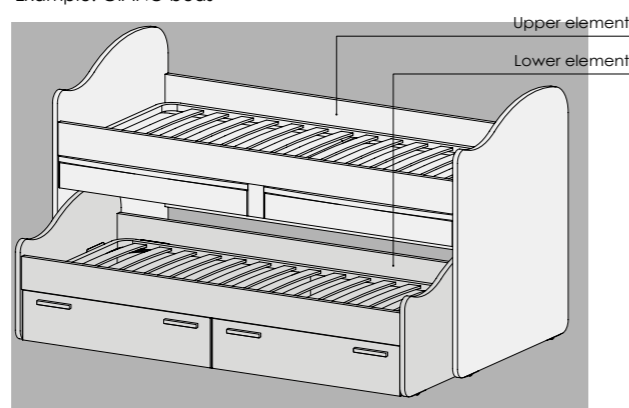

Metal ladder with fixing  
NOT on top bed BASSO  
Ht 96.4 - W 32.5

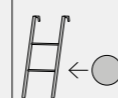

<b>Code</b>	<b>PL44.92B</b>
ONE	
CLUB	

Metal bed frame  
Dpt 193 - Ht 29

With 4 castor wheels with brake  
W 98

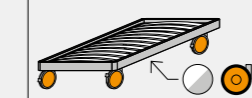

<b>Code</b>	<b>P52.87E</b>
ONE	
CLUB	

Somier  
Dpt 200 - Ht 29

With 4 castor wheels with brake  
W 98

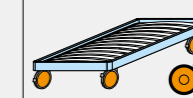

<b>Code</b>	<b>P66.82T</b>
ONE	
CLUB	

- Components in **GROUP 2 colors**
- Components in **Types and colors FRONT**
- Shaped components available with contrasting edging.
- Is available in two colors.

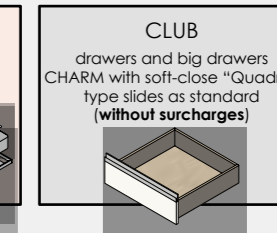
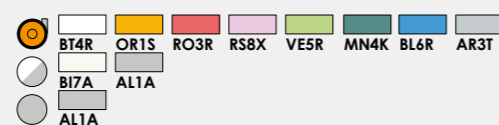

# MUVI wheeled beds with W 80 base

**Built in self-braking casters.**  
 Slatted bed base included.  
 Structural bed base for high bed W 83 D 203.  
 Bed base for low bed W 80 D 190.  
 Elements can not be modified.

Example: ORIGINAL type

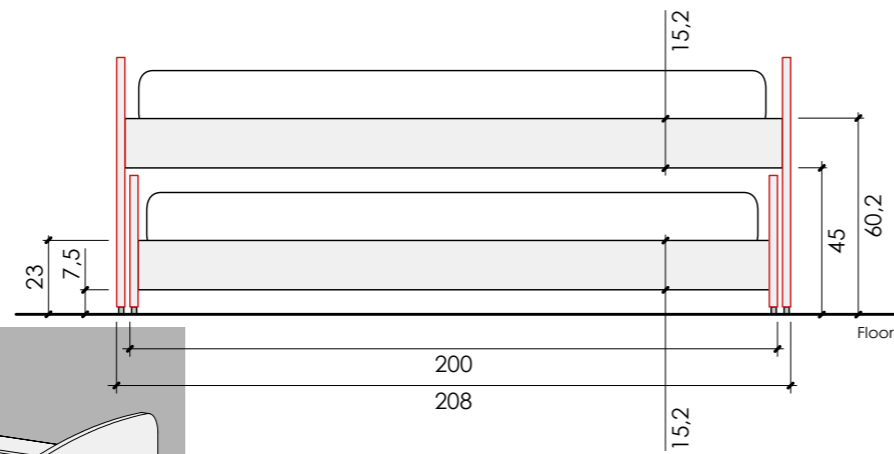
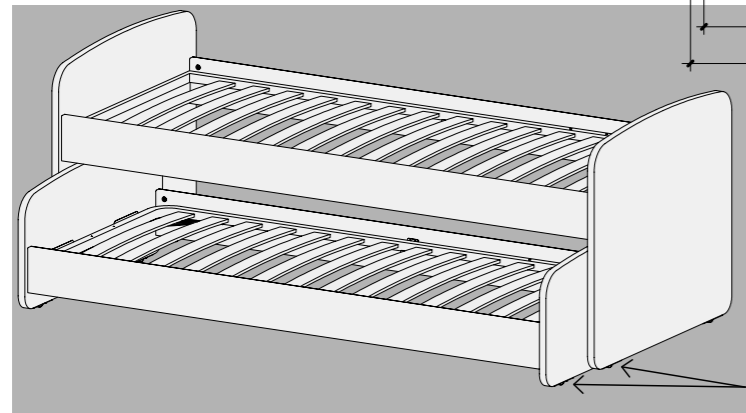

Built in self-braking casters.

Use the: mattress **200 x 80** (for high beds) **190 x 80** (for low beds)

## ORIGINAL type

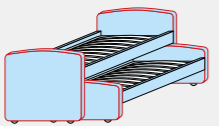
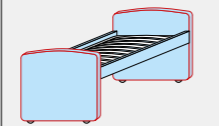
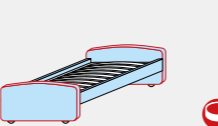

	Pair of beds	High single bed	Low single bed
			
	Ht 79 Dpt 208 W 89	Ht 79 Dpt 208 W 89	Ht 42 Dpt 200 W 89
<b>Code</b>	<b>PL51.00E</b>	<b>PL51.01M</b>	<b>PL51.02T</b>

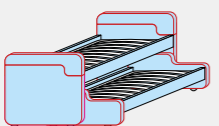
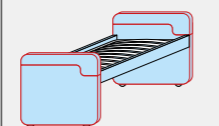
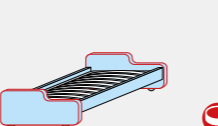
## LOVE type

	Pair of beds	High single be	Low single bed
			
	Ht 81 Dpt 208 W 89	Ht 81 Dpt 208 W 89	Ht 43 Dpt 200 W 89
<b>Code</b>	<b>PL51.03Z</b>	<b>PL51.04F</b>	<b>PL51.05N</b>

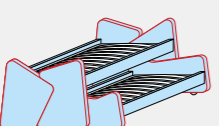
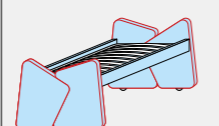
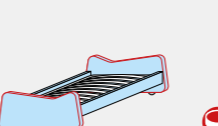
## TWIST type

	Pair of beds	High single bed	Low single bed
			
	Ht 79 Dpt 208 W 99	Ht 79 Dpt 208 W 99	Ht 43 Dpt 200 W 92,5
<b>Code</b>	<b>PL51.06U</b>	<b>PL51.07A</b>	<b>PL51.08G</b>

-  Components in **GROUP 2 colors**
-  Shaped components available with contrasting edging.
-  Is available in two colors.





# GRETA container ladder with shaped sides

For MULTIFUNCTION bed

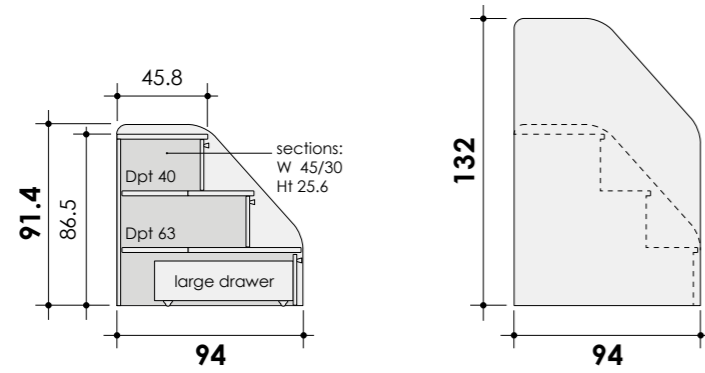

**W 50**  
Ht 91.4  
Dpt 94



**P97.40Z**

ONE matte  
glossy

CLUB

**W 50**  
Ht 132  
Dpt 94

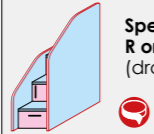

**P97.42L**

Specify  
R or L  
(drawing shows R)

**W 35**  
Ht 91.4  
Dpt 94



**P05.07U**

ONE matte  
glossy

CLUB

**W 35**  
Ht 132  
Dpt 94

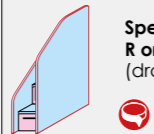

**P05.09E**

Specify  
R or L  
(drawing shows R)

Components in **GROUP 2 colors**

Components in **Types and colors FRONT**

Shaped components available with contrasting edging.

Is available in two colors.

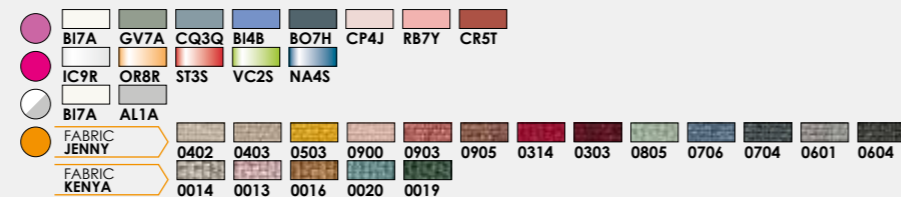

# MULTIFUNCTION and MUVI bed guards

**ZIG-ZAG guards**  
In lacquered MDF board.  
Ht 37

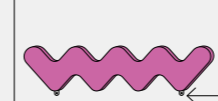

**W**

**Code**

**150**

**P98.98T**

**183**

**P98.99Y**

**LONG guards**  
In polyurethane varnished.  
Ht 29



**Code**

**P97.13C**

**P97.14H**

**LOVE guards**  
Melamine-coated.  
Ht 30 - Th 1.8

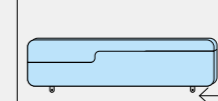

**Code**

**P07.89W**

**P07.90B**

**BALLOON guard**  
Melamine-coated.  
Ht 40 - Th 2.5

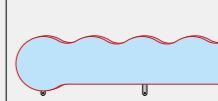

**Code**

**-**

**P99.00P**

**FLIK guards**  
Melamine-coated.  
Ht 35 - Th 2.5

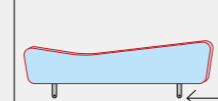

**W**

**Code**

**150**

**PL51.09P**

**183**

**PL51.49L**

**POLDO guards**  
Melamine-coated.  
Ht 24 - Th 2.5

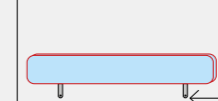

**Code**

**PL51.10L**

**PL51.50G**

**POLDO guards**  
Melamine-faced, padded and covered with fabric. Removable.  
Ht 24 - Th 3.5

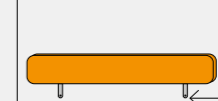

**Code**

**PL51.11S**

**PL51.51P**

**POLDO guards**  
Melamine-faced, padded and covered with fabric with 3 pockets. Removable.  
Ht 24 - Th 3.5



**Code**

**PL51.12Y**

**PL51.52V**

**Methacrylate guard**  
W 95 - Ht 40.4



**Code**

**P65.74W**

**Metal guard**  
W 95 - Ht 38



**Code**

**P48.24E**

**Fabric guard cover**  
Cotton fabric with two pockets.  
For metal guard  
W 55 - Ht 38



**Code**

**PL51.53B**





## Container beds

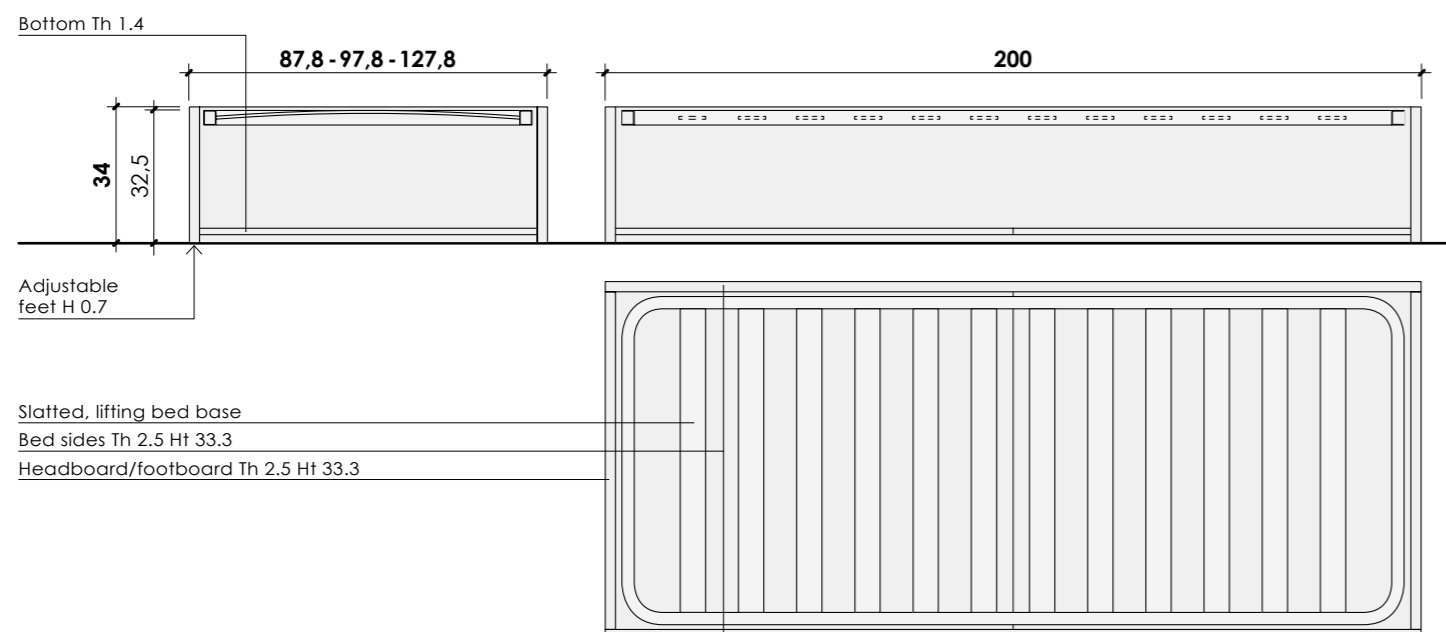

## Containers and auxiliary containers

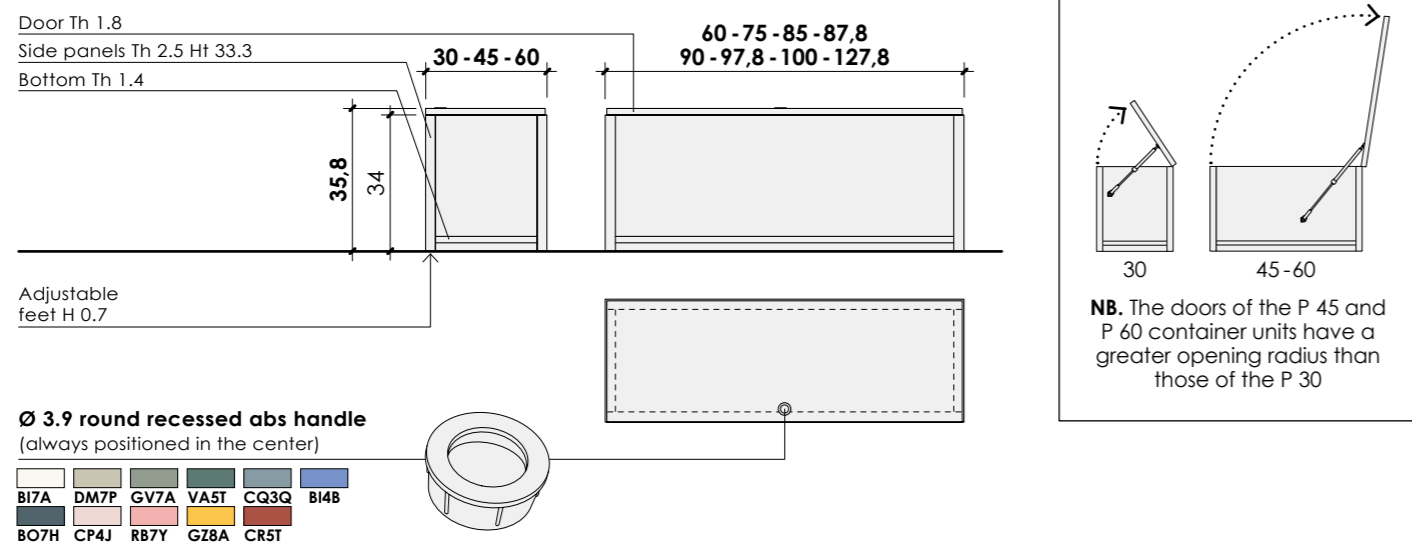

### Example of using containers:

To create a FLOTTA composition, simply choose from the available elements (see opposite page), rotate them (if necessary) and place them next to each other, positioning them as desired. When finished positioning, secure the containers with the hardware provided.

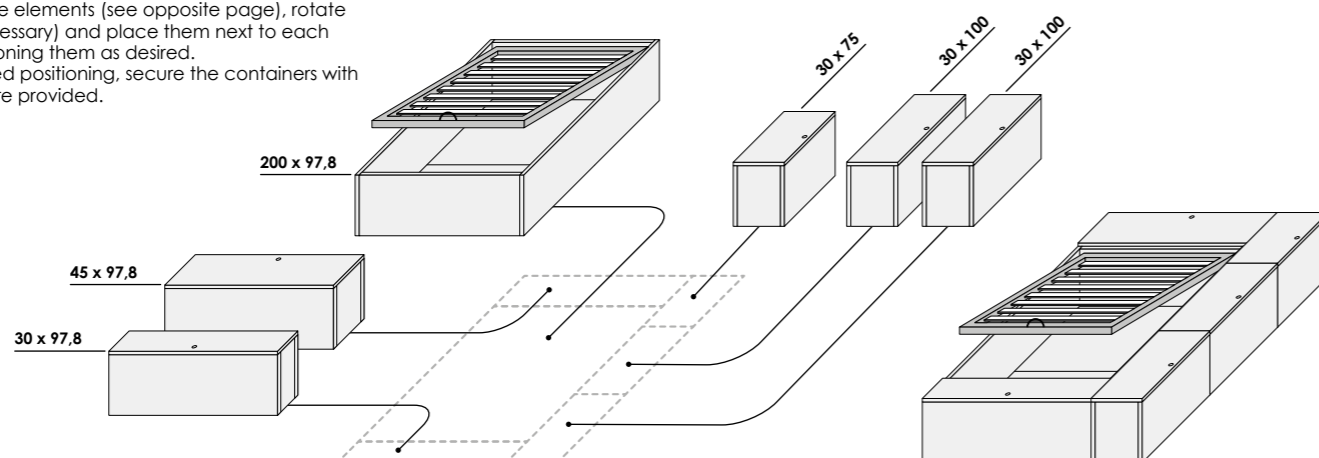

Components in GROUP 2 colors

## Container beds with slatted, lifting bed base

	200 x 87,8	200 x 97,8	200 x 127,8
	Use the: mattress 190 x 80	Use the: mattress 190 x 90	Use the: mattress 190 x 120
	Space inside container: W 83 Ht 23 Dpt 195	Space inside container: W 93 Ht 23 Dpt 195	Space inside container: W 123 Ht 23 Dpt 195
<b>Code</b>	<b>PK48.00E</b>	<b>PK48.01M</b>	<b>PK48.02T</b>

## Containers for headboard and footboard

	30 x 87,8	30 x 97,8	30 x 127,8	Custom made: 30 x 60 min ÷ 127,8 max
<b>Code</b>	<b>PK48.03Z</b>	<b>PK48.04F</b>	<b>PK48.05N</b>	<b>PK48.06U</b>

## Containers for headboard and footboard

	45 x 87,8	45 x 97,8	45 x 127,8
<b>Code</b>	<b>PK48.07A</b>	<b>PK48.08G</b>	<b>PK48.09P</b>

## Containers for headboard and footboard

	60 x 87,8	60 x 97,8
<b>Code</b>	<b>PK48.10L</b>	<b>PK48.11S</b>

## Auxiliary containers

	30 x 60	30 x 75	30 x 85	30 x 90	30 x 100
<b>Code</b>	<b>PK48.12Y</b>	<b>PK48.13E</b>	<b>PK48.14M</b>	<b>PK48.15T</b>	<b>PK48.16Z</b>



# FLOTTA system



## Compositions with bed 200 x 87.8

Use the: mattress 190 x 80

	Dpt 275 W 87,8	Dpt 290 W 87,8	Dpt 230 W 117,8
<b>Code</b>	<b>PK48.20R</b>	<b>PK48.21X</b>	<b>PK48.22D</b>

	Dpt 245 W 117,8	Dpt 260 W 117,8	Dpt 290 W 117,8
<b>Code</b>	<b>PK48.23L</b>	<b>PK48.24S</b>	<b>PK48.25Y</b>

	Dpt 327,8 W 290	Dpt 200 W 377,8
<b>Code</b>	<b>PK48.26E</b>	<b>PK48.27M</b>

## Compositions with bed 200 x 97.8

Use the: mattress 190 x 90

	Dpt 275 W 97,8	Dpt 290 W 97,8	Dpt 230 W 127,8
<b>Code</b>	<b>PK48.30W</b>	<b>PK48.31C</b>	<b>PK48.32K</b>

	Dpt 245 W 127,8	Dpt 260 W 127,8	Dpt 290 W 127,8
<b>Code</b>	<b>PK48.33R</b>	<b>PK48.34X</b>	<b>PK48.35D</b>

	Dpt 320 W 127,8	Dpt 335 W 127,8
<b>Code</b>	<b>PK48.36L</b>	<b>PK48.37S</b>

	Dpt 200 W 285,6
<b>Code</b>	<b>PK48.38Y</b>

Components in GROUP 2 colors



# FLOTTA system

## Compositions with bed 200 x 127.8

Use the: mattress 190 x 120

	<p>Dpt 275 W 127,8</p>	<p>Dpt 290 W 127,8</p>	<p>Dpt 230 W 157,8</p>
<b>Code</b>	<b>PK48.40B</b>	<b>PK48.41K</b>	<b>PK48.42Q</b>

	<p>Dpt 245 W 157,8</p>	<p>Dpt 260 W 157,8</p>	<p>Dpt 305 W 157,8</p>
<b>Code</b>	<b>PK48.43W</b>	<b>PK48.44C</b>	<b>PK48.45K</b>

	<p>Dpt 320 W 157,8</p>		
<b>Code</b>	<b>PK48.46R</b>		

Components in **GROUP 2 colors**



**GROUP 1 colors**

**GROUP 2 colors**

**GROUP 3 colors**

**CARCASE colors**

- Rovere Dorian RD5T
- Ciliegio bianco CB6K
- Noce NC4B
- Bianco opaco B17A
- Rovere white RW3Q
- Malta ML7H
- Desert DS9L
- Grigio Dorian GL4R
- Agave GV7A
- Blu opale BO7H
- Noce naturale NN7H
- Feltro FL8X
- Canapa CN1X
- Basalto BS5T
- Verde Alpi VA5T
- Eucalipto CL1X
- Cemento Masdar CM3Q
- Moka MK6B
- Grigio titanio GZ8T
- Cadaques CQ3Q
- Domy DM7P
- Blu indaco BI4B
- Cipria CP4J
- Rosa bubble RB7Y
- Giallo zafferano GZ8A
- Corallo CR5T
- Bianco UV BU3Q

**Types and colors FRONT**

**ONE**

matte

glossy

- Rovere white RW3Q
- Feltro FL8X
- Basalto BS5T
- Blu opale BO7H
- Rovere Dorian RD5T
- Cemento Masdar CM3Q
- Grigio titanio GZ8T
- Cipria CP4J
- Ciliegio bianco CB6K
- Bianco opaco B17A
- Domy DM7P
- Rosa bubble RB7Y
- Noce naturale NN7H
- Desert DS9L
- Agave GV7A
- Giallo zafferano GZ8A
- Noce NC4B
- Canapa CN1X
- Verde Alpi VA5T
- Corallo CR5T
- Eucalipto CL1X
- Moka MK6B
- Cadaques CQ3Q
- Malta ML7H
- Grigio Dorian GL4R
- Blu indaco BI4B
- Bianco UV BU3Q

**CLUB**

- Rovere white RW3Q
- Feltro FL8X
- Basalto BS5T
- Blu opale BO7H
- Rovere Dorian RD5T
- Cemento Masdar CM3Q
- Grigio titanio GZ8T
- Cipria CP4J
- Ciliegio bianco CB6K
- Bianco opaco B17A
- Domy DM7P
- Rosa bubble RB7Y
- Noce naturale NN7H
- Desert DS9L
- Agave GV7A
- Giallo zafferano GZ8A
- Noce NC4B
- Canapa CN1X
- Verde Alpi VA5T
- Corallo CR5T
- Eucalipto CL1X
- Moka MK6B
- Cadaques CQ3Q
- Malta ML7H
- Grigio Dorian GL4R
- Blu indaco BI4B
- Bianco UV BU3Q

Specify the color of the CLUB handle

- Bianco opaco B17A
- Domy DM7P
- Rosa bubble RB7Y
- Desert DS9L
- Agave GV7A
- Giallo zafferano GZ8A
- Canapa CN1X
- Verde Alpi VA5T
- Corallo CR5T
- Moka MK6B
- Cadaques CQ3Q
- Grigio Dorian GL4R
- Blu indaco BI4B
- Basalto BS5T
- Blu opale BO7H
- Grigio titanio GZ8T
- Cipria CP4J

**WINDOW**

- Trasparente TR9M
- Trasparente fumé FT8P
- Stop-sol ST6P
- Specchio SP7L
- Alluminio AL1A
- Titan grey TG7H

Specify the color of the aluminum frame

**Groups and Single beds**

Groups with top and with top and base technical information	356
OPTIONAL groups with top and with top and base	357
Groups with top	358
Groups with top and base	359
POLDO bedside tables and baskets	360
BRICK group	361
PODIO bench Dpt 49 - Ht 8	362
Bench Dpt 41 - Ht 10	362
Mirror	363
Single beds with headboard and footboard	364
Single beds with ATLANTE bed frame	368
Single beds with GIOVE bed frame	374
Single beds with MARTE bed frame	380
Single beds with NETTUNO bed frame	382
Single beds with SIGMA bed frame	384
Single beds with metal bed frame	386
Single beds with somier	388
Padded single beds	390
Padded single beds ECOCHIC	392
Single ottomans with headboard and footboard	394
Sofa beds	398
Bed and sofa bed with second automatic lifting base	400
BAIA sofa beds and desks	402
Accessories for beds	404

All the tallboys and dressers are supplied with anti-tip hardware for fastening to the wall.

All measurements are expressed in centimeters; with tolerance ± 2 cm for upholstered items. The recommended maximum weights of mattresses for beds with lift-up bed base are shown in the table alongside.

	Lifting bed base width	Max mattress weight
	80 - 90	20 Kg
	120	30 Kg

# Groups with top and with top and base technical information

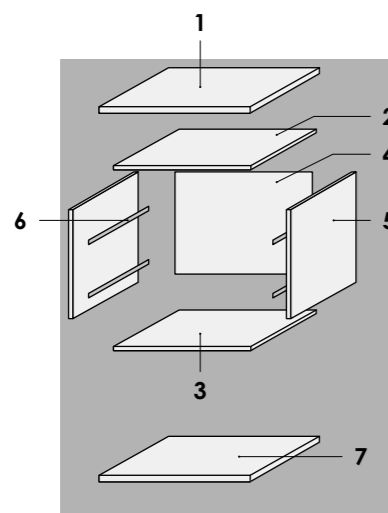

Components:

- 1 Top panel Th 2.5
- 2 Top panel Th 1.8
- 3 Bottom panel Th 1.8  
The bottom panel can be fitted with:
  - ALFA-25 adjustable feet Ht 2.5
  - DELTA adjustable feet Ht 11
  - NUME adjustable feet Ht 11
  - EPSILON adjustable feet Ht 15.5
  - TWIG adjustable feet Ht 16
  - Castor wheels Ht 8
- 4 Back panel Th 0.3
- 5 Side panels Th 1.8
- 6 Metal drawer runners
- 7 Base Th 2.5  
The base can be fitted with:
  - DELTA adjustable feet Ht 11
  - NUME adjustable feet Ht 11
  - EPSILON adjustable feet Ht 15.5
  - TWIG adjustable feet Ht 16
  - Castor wheels Ht 8

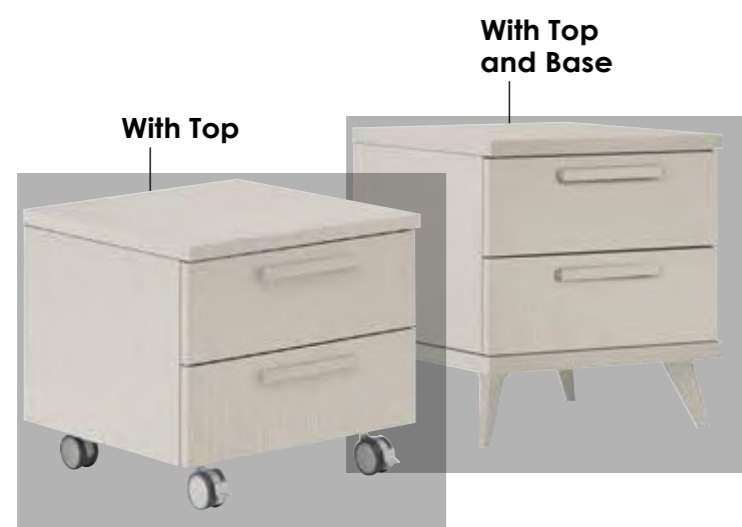

- Top panel, bottom panel and back panel in carcass colours.
- Custom-made cuts are not carried out.
- The drawers and big drawer CLUB are always fitted with height-adjustable, soft-close, "Quadro", metal slides with interior CHARM finish.
- It is compulsory to complete the elements with feet or wheels.

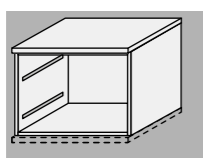

### Bedside tables

Dimensions:  
**W** 45 - 60 - 90  
**Dpt** 45,8  
**Ht** 34,5 - 53  
**Ht** 37 (with base)

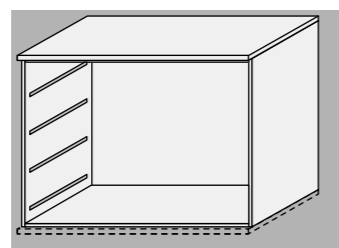

### Chests of drawers

Dimensions:  
**W** 90  
**Dpt** 57,1  
**Ht** 66,5  
**Ht** 69 (with base)

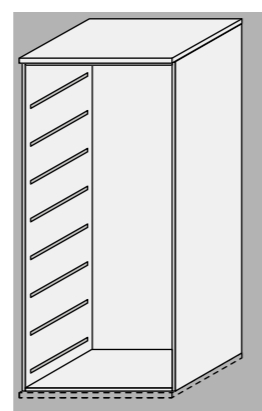

### Tallboys

Dimensions:  
**W** 60 - 90  
**Dpt** 45,8 - 57,1  
**Ht** 98,5 - 130,5  
**Ht** 101,5 - 133,5 (with base)

# OPTIONAL groups with top and with top and base

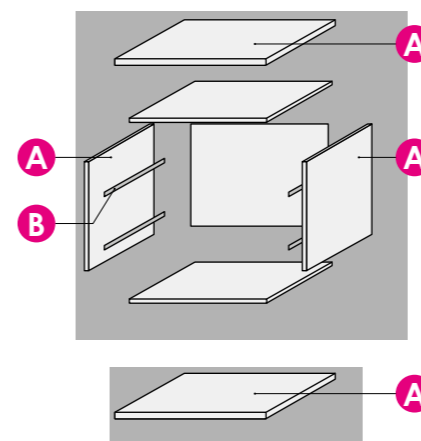

### A Extra colors for Side panels (+ Top / + Top and Base)

In addition to the standard CARCASE colors, the side panels are available in all the GROUP 2 colors with surcharge (see table).  
 • **When placing the order:** indicate the colour in the COLOURED FINISHES variant in Metron 4: all side panels will automatically be delivered in that colour.  
 • **N.B.** The colour of the side panels will also determine the colour of the Top panel and of the Top panel and base.

### B Drawers and big drawers with soft-close

On request drawers and larger drawers in the "standard" version can be equipped with soft-close mechanisms, with surcharge (see table). Alternatively, drawers and big drawers can be ordered in the CHARM version, with surcharge (see table), equipped with height-adjustable "Quadro" type runners with prestigious internal finish.  
 • **When placing the order:** indicate the type of runners in the RUNNER TYPE variant in Metron 4.  
 • **N.B.** the CLUB drawers and big drawers are standard in the CHARM soft-close "Quadro" type runners version (without surcharge).

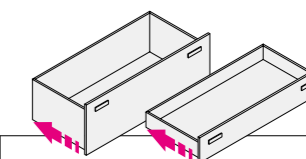

Side panel	Surcharge for single element (CARCASE colors excluded)
Bedside table	
Bedside table Ht 53	
Chest of drawers	
Tallboy H 98.5/101.5 - Dpt 57.1/45.8	
Tallboy H 130.5/133.5 - Dpt 57.1/45.8	

Slow closing	Surcharge for single element
Drawers W 45 - 60 - 90	
Big drawers W 45 - 60 - 90	
CHARM Drawers/Big drawers with "Quadro" slides W 45 - 60 - 90	

# Groups with top

It is compulsory to complete with feet or wheels

## Bedside tables

Ht 34.5  
Dpt 45.8

Without feet and wheels

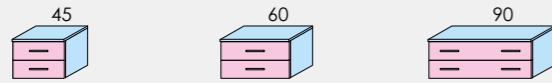

Code	PL38.11R	PL38.12X	PL38.13D	PL38.14L
ONE	matte			
	glossy			
CLUB				

## Chests of drawers

Ht 66.5  
Dpt 57.1

Without feet and wheels

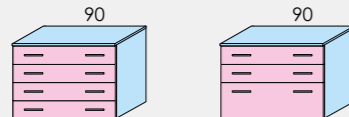

Code	PL38.15S	PL38.16Y
ONE	matte	
	glossy	
CLUB		

## Tallboys

Ht 98.5

Dpt 57.1

Dpt 45.8

Without feet and wheels

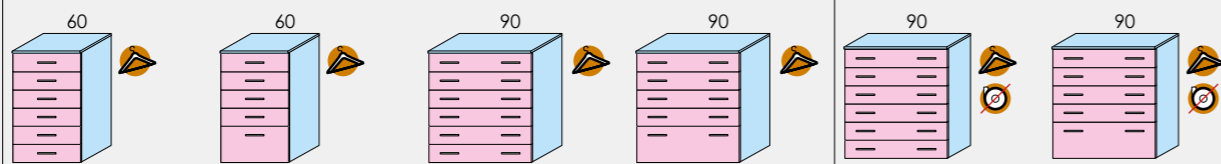

Code	PL38.17E	PL38.18M	PL38.19T	PL38.20Q	PL38.21W	PL38.22C
ONE	matte					
	glossy					
CLUB						

## Tallboys

Ht 130.5

Dpt 57.1

Without feet and wheels

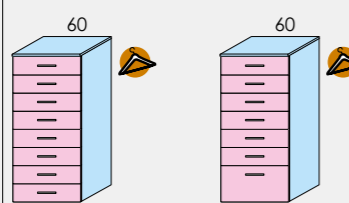

Code	PL38.23K	PL38.24R
ONE	matte	
	glossy	
CLUB		

## Feet and wheels usable

Adjustable feet - Pack of 4

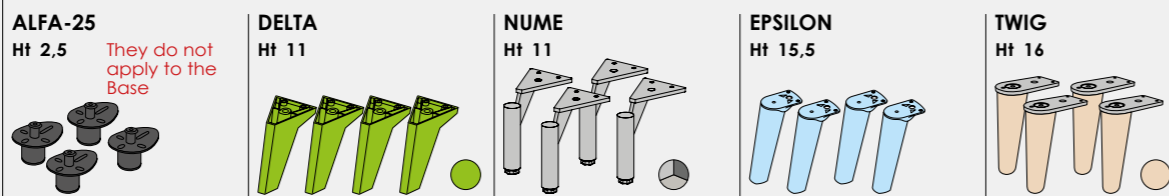

Code	P13.64Z	P07.60P	PK50.00Y	P08.37S	PK50.01E
------	---------	---------	----------	---------	----------

■ Components in **GROUP 2 colors**  
■ Components in **Types and colors FRONT**  
 Equippable with BERNARDO  
 The element can not be equipped with wheels

	BT4R	OR1S	RO3R	RS8X	VE5R	MN4K	BL6R	AR3T	BN7A	AR3T	* With brake
	B17A	GZ8T	GV7A	CQ3Q	BI4B	BO7H	CP4J	RB7Y	CR5T	AL1A	
	B17A	GZ8T									
	AL1A	GZ8T	CH2M								

**Solid natural ash wood**  
Wood is a natural product and, as such, is subject to variations in color and grain. Differences in grain or color therefore do not constitute grounds for dispute.

# Groups with top and base

It is compulsory to complete with feet or wheels

## Bedside tables

Ht 37  
Dpt 45.8

Without feet and wheels

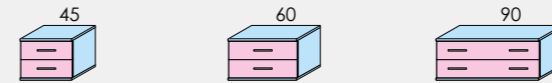

Code	PL38.31B	PL38.32H	PL38.33Q
ONE	matte		
	glossy		
CLUB			

## Chests of drawers

Ht 69  
Dpt 57.1

Without feet and wheels

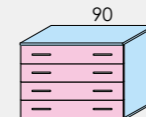

Code	PL38.34W
ONE	matte
	glossy
CLUB	

## Tallboys

Ht 101.5

Dpt 57.1

Dpt 45.8

Without feet and wheels

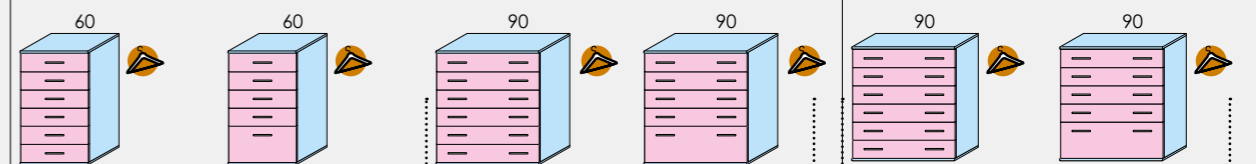

Code	PL38.35C	PL38.36K	PL38.37R	PL38.38X	P38.38D	P65.54N
ONE	matte					
	glossy					
CLUB						

Elements with felt pads

Elements with felt pads  
**Feet and wheels cannot be fitted**

## Tallboys

Ht 133.5

Dpt 57.1

Without feet and wheels

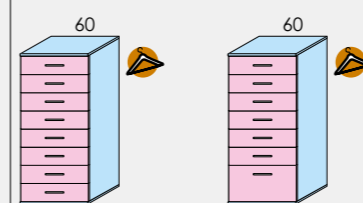

Code	PL38.39D	PL38.40A
ONE	matte	
	glossy	
CLUB		

## Castor wheels

Pack of 4



Ht 8  
P07.72D

## BERNARDO

Clothes hangers

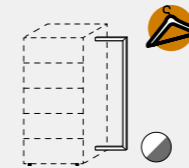

Ht 96  
Dpt 2  
W 28  
P07.70T

**OPTIONAL:** p. 357  
**A** - Extra colors for Side panels (+ Top / + Top and Base)  
**B** - Drawers and big drawers with soft-close

**CLUB**  
drawers and big drawers  
CHARM with "Quadro" type  
soft rails as standard  
(without surcharges)

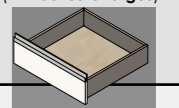

p. 56 Knob and handle positions



# POLDO bedside tables and baskets



- Th 2.5 top and side panels.
- Th 1.8 drawers and big drawers.
- The drawers and big drawer CLUB are always fitted with height-adjustable soft-close "Quadro" metal slides with interior CHARM finish (without surcharges).
- Protective feet Ht 0.3.
- **At your discretion you can assemble Ht 8 castor wheels (Ht 48 total).**
- Element can not be modified.



## Bedside tables Ht 43.5 Dpt 53

2 drawers Ht 16

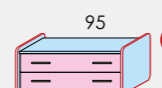
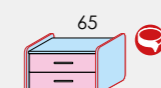

1 big drawer Ht 32

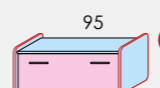
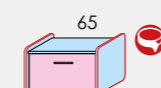
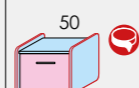

<b>Code</b>	<b>PL38.00D</b>	<b>PL38.01L</b>	<b>PL38.02S</b>	<b>PL38.03Y</b>	<b>PL38.04E</b>	<b>PL38.05M</b>
ONE	matte					
	glossy					
CLUB						

## Baskets Ht 43.5 Dpt 53

inner space:  
45 x 41 x Ht 31.5

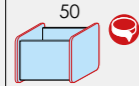

inner space:  
60 x 41 x Ht 31.5

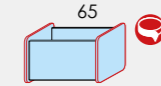

inner space:  
90 x 41 x Ht 31.5

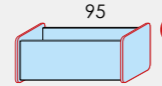

<b>Code</b>	<b>PL38.06T</b>	<b>PL38.07Z</b>	<b>PL38.08F</b>			
-------------	-----------------	-----------------	-----------------	--	--	--

### Castor wheels

Pack of 4

Ht 8



<b>Code</b>	<b>P07.72D</b>			
-------------	----------------	--	--	--

■ Components in **GROUP 2 colors**  
■ Components in **GROUP 3 colors**  
■ Components in **Types and colors FRONT**  
 Shaped components available with contrasting edging.  
 Equippable with BERNARDO

	BT4R	OR1S	RO3R	RS8X	VE5R	MN4K	BL6R	AR3T	BN7A	AR3T	* With brake
	B17A	GZ8T	GV7A	CQ3Q	BI4B	BO7H	CP4J	RB7Y	CR5T	AL1A	
	B17A	GV7A	CQ3Q	BI4B	BO7H	CP4J	RB7Y	CR5T			
	B17A	GZ8T									
	AL1A	GZ8T	CH2M								

# BRICK group



- Top, side panels and back panel Th 1.8.
- Drawers Th 1.8.
- **Provided with "Quadro" type metal slides which have adjustable height and soft-close system. Drawers internal color CHARM.**
- In the Chest of drawers, in the presence of handles with pitch 256, 320 and 960, there will be only one handle in the central position.
- Ht 0.7 adjustable feet.
- **At your discretion you can assemble ALFA-25, DELTA, NUME, EPSILON and TWIG feet.**

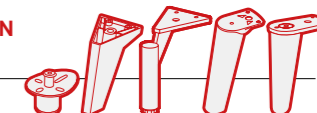

### Chest of drawers

Ht 73  
Dpt 57  
W 120  
With 3 drawers Ht 24

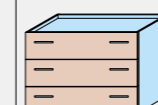

### Tallboy

Ht 121  
Dpt 46,5  
W 60  
With 5 drawers Ht 24

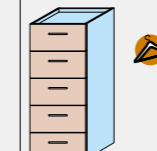

### Bedside tables (with finished back panel)

Ht 33 Dpt 46,5 W 45 With 2 drawers Ht 16	Ht 33 Dpt 46,5 W 45 With 1 drawer Ht 32
---	--



<b>Code</b>	<b>PK54.14X</b>	<b>PK54.15D</b>	<b>PK54.16L</b>	<b>PK54.17S</b>	
-------------	-----------------	-----------------	-----------------	-----------------	--

### TWIG small table

Ht 44  
Ø 34

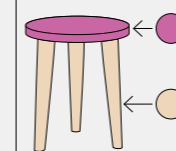

<b>Code</b>	<b>PK50.06N</b>				
-------------	-----------------	--	--	--	--

### Adjustable feet

**ALFA-25**  
Ht 2,5



**DELTA**  
Ht 11



**NUME**  
Ht 11

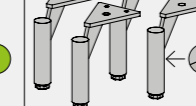

**EPSILON**  
Ht 15,5

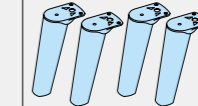

**TWIG**  
Ht 16

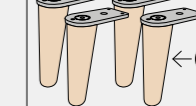

<b>Code</b>	<b>P13.64Z</b>	<b>P07.60P</b>	<b>PK50.00Y</b>	<b>P08.37S</b>	<b>PK50.01E</b>
-------------	----------------	----------------	-----------------	----------------	-----------------

### BERNARDO

Clothes hangers

Ht 96  
Dpt 2  
W 28

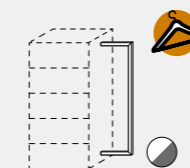

<b>Code</b>	<b>P07.70T</b>			
-------------	----------------	--	--	--

**Solid natural ash wood**  
Wood is a natural product and, as such, is subject to variations in color and grain. Differences in grain or color therefore do not constitute grounds for dispute.

## PODIO bench Dpt 49 - Ht 8

- With adjustable feet.
- Element can not be modified.
- Finishes are on 3 sides (needs positioning against the wall).

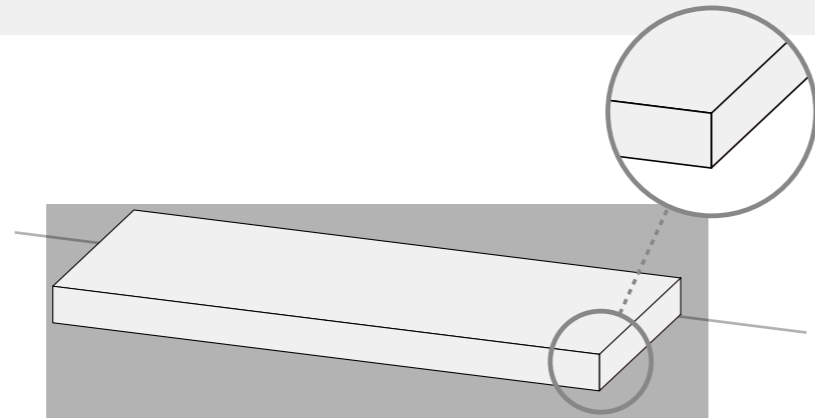

	90	120	150	
<b>Code</b>	<b>PL48.84B</b>	<b>PL48.85H</b>	<b>PL48.86Q</b>	

### Back panels

Wall fixing with the provided hardware.

Ht 27,5

Th 1,8

	90	120	150	
<b>Code</b>	<b>PL48.81G</b>	<b>PL48.82P</b>	<b>PL48.83V</b>	

## Bench Dpt 41 - Ht 10

- Top and structure made with Th 1.8 panels.
- With adjustable feet.
- Element can not be modified.
- Finishes are on all of the four sides (it can be placed in any position).
- You can use Modular self standing elements D 45 or 32.5.

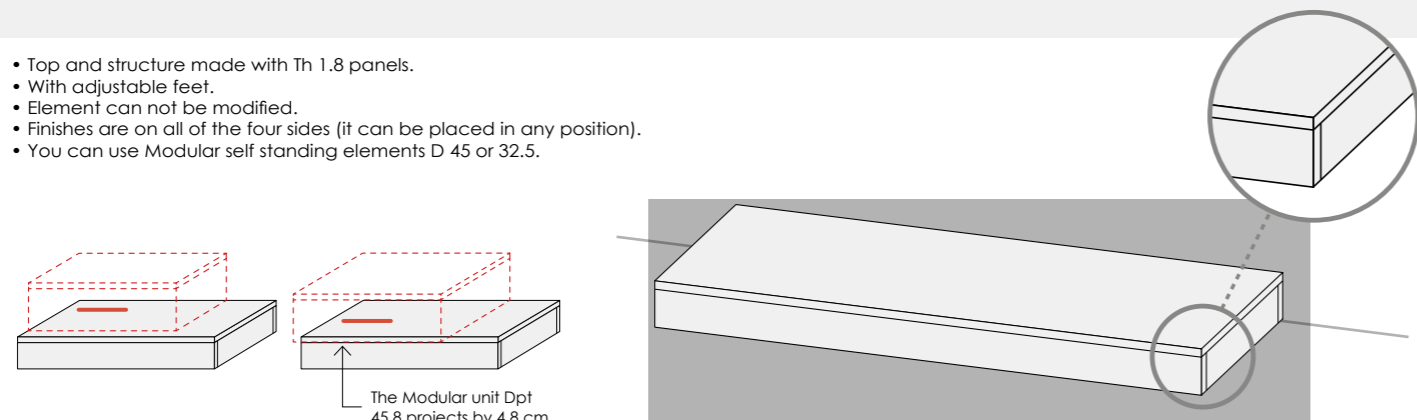

	45	60	90	120	
<b>Code</b>	<b>P78.97H</b>	<b>P78.98P</b>	<b>P78.99U</b>	<b>P78.49X</b>	

<input type="checkbox"/> Components in <b>CARCASE</b> colors	<input type="checkbox"/> RW3Q	<input type="checkbox"/> RD5T	<input type="checkbox"/> CB6K	<input type="checkbox"/> NN7H	<input type="checkbox"/> NC4B	<input type="checkbox"/> CL1X	<input type="checkbox"/> ML7H	<input type="checkbox"/> CM3Q	<input type="checkbox"/> DS9L	<input type="checkbox"/> CN1X	<input type="checkbox"/> MK6B	<input type="checkbox"/> GL4R	<input type="checkbox"/> BS5T	<input type="checkbox"/> GZ8T
<input type="checkbox"/> Components in <b>GROUP 2</b> colors	<input type="checkbox"/> 0111	<input type="checkbox"/> 0102	<input type="checkbox"/> 0603	<input type="checkbox"/> 0415	<input type="checkbox"/> 0503	<input type="checkbox"/> 0605	<input type="checkbox"/> 0700	<input type="checkbox"/> 0608	<input type="checkbox"/> 0901					
<input type="checkbox"/> Mirror.														

## Mirror

### Frame Th 2.5

	Ht 80 W 80	Ht 112 W 60	Ht 190 W 80	
<b>Code</b>	<b>P92.58F</b>	<b>P92.59M</b>	<b>P92.60S</b>	

### With coloured uprights Dpt 1.8

	Ht 90 W 60	Ht 180 W 60		
<b>Code</b>	<b>PK50.95E</b>	<b>PK50.96M</b>		

### Faux leather frame Th 2.5

	Ht 80 W 80	Ht 185 W 80		
<b>Code</b>	<b>PL50.30S</b>	<b>PL50.31Y</b>		

### Mirrors with biadhesive tape

P30.44L can be mounted on the insides of doors.

	∅ 50	∅ 80	Ht 80 W 80	Ht 147 W 32	Ht 125 W 60
<b>Code</b>	<b>H35.31A</b>	<b>P92.56V</b>	<b>P92.57A</b>	<b>P30.44L</b>	<b>P30.45R</b>

# Single beds with headboard and footboard



## Without base

Model	ELFO	R GIANO	L GIANO	HOLE	LOVE	NORMALE	NUBE
Ht	75	82	82	86,5	86,5	79	86
Dpt	197 207	197 207	197 207	197 207	197 207	197,4	199 209
W	90 100 129	90 100 -	90 100 -	89 100 129,2	89 100 129,2	90 -	90 100 -
bed base W	80 x 190	90 x 190	120 x 190	80 x 190	90 x 190	120 x 190	80 x 190
Code	P42.04BP	P43.80T	P43.00H	PL40.07T	PL40.04Y	P42.01LP	P43.66S
internal dimensions	191 x 81,5	191 x 81,5	191 x 81,5	191 x 81,5	191 x 81,5	191 x 81,5	191 x 81,5
Code	P41.54VP	P41.32A	P41.31V	PL41.07X	PL41.04C	-	P41.34M
internal dimensions	191 x 91,5 201 x 91,5	191 x 91,5 201 x 91,5	191 x 91,5 201 x 91,5	191 x 91,5 201 x 91,5	191 x 91,5 201 x 91,5	-	191 x 91,5 201 x 91,5
Code	P42.84MP	-	-	PL42.05P	PL42.03A	-	-
internal dimensions	191 x 121 201 x 121	-	-	191 x 121 201 x 121	191 x 121 201 x 121	-	-
Custom-made beds	P42.95WP	-	-	-	-	-	-
Max W 205	per cm fixed charge	-	-	-	-	-	-

## Fitted with 2<sup>nd</sup> base W 80 and slatted base

For the 2<sup>nd</sup> bed base mattress Ht 17 max

Model	ELFO	R GIANO	L GIANO	HOLE	LOVE	NORMALE
Ht	75	82	82	86,5	86,5	79
Dpt	200	200	200	200	200	200
W	90 100	90 100	90 100	89 100	89 100	90 -
bed base W	80 x 190	90 x 190	120 x 190	80 x 190	90 x 190	120 x 190
Code	P44.69M	P44.78L	P44.79R	PL40.08Z	PL40.05E	P44.02X
internal dimensions	194 x 81,5	194 x 81,5	194 x 81,5	194 x 81,5	194 x 81,5	194 x 81,5
Code	P41.56F	P41.90R	P41.89L	PL41.08D	PL41.05K	-
internal dimensions	194 x 91,5	194 x 91,5	194 x 91,5	194 x 91,5	194 x 91,5	-

## Fitted with big drawers and slatted base

Model	ELFO	R GIANO	L GIANO	HOLE	LOVE	NORMALE
Ht	75	82	82	86,5	86,5	79
Dpt	200	200	200	200	200	200
W	91 101	91 101	91 101	90,5 101	90,5 101	91 -
bed base W	80 x 190	90 x 190	120 x 190	80 x 190	90 x 190	120 x 190
Code	P44.74P	P44.83N	P44.84T	PL40.09F	PL40.06M	P44.16Y
internal dimensions	194 x 81,5	194 x 81,5	194 x 81,5	194 x 81,5	194 x 81,5	194 x 81,5
Code	P41.58S	P41.94N	P41.93G	PL41.09L	PL41.06R	-
internal dimensions	194 x 91,5	194 x 91,5	194 x 91,5	194 x 91,5	194 x 91,5	-

## Fitted with slatted LIFTABLE base

Space inside container  
Ht 19,5 - Dpt 197 - W 83/123

Model	R GIANO	L GIANO	HOLE	LOVE
Ht	82	82	86,5	86,5
Dpt	200	200	200	200
W	90	90	89	89
bed base W	80 x 190	120 x 190	80 x 190	90 x 190
Code	PL40.52N	PL40.51F	PL40.56P	PL40.55G
internal dimensions	195 x 80	195 x 80	195 x 80	195 x 80

- Components in **CARCASE** colors
- Components in **GROUP 2** colors
- Components in **Types and colors FRONT**

- \* When ordering, it is essential to state the width and depth of base. Base to be supplied by the customer.
- Shaped components available with contrasting edging.
- The headboard and foot panel can be two-coloured.



When ordering, specify for bed base Dpt 190 or 200.

# Single beds with headboard and footboard

**Without base**

Model	Code	internal dimensions	Model	Code	internal dimensions	Model	Code	internal dimensions	Model	Code	internal dimensions	Model	Code	internal dimensions
<b>POLDO</b> Ht 86 Dpt 197 W 98 108 137,5	<b>PL40.44V</b>	191 x 81,5	<b>POLDO SOFT</b> Ht 90 Dpt 201 W 98 108 137,5	<b>PK50.07U</b>	191 x 81,5	<b>R SCHEMA</b> Ht 86 Dpt 197 W 88,4 98,4 127,8	<b>P04.76R</b>	191 x 81,5	<b>L SCHEMA</b> Ht 86 Dpt 197 W 88,4 98,4 127,8	<b>P04.75L</b>	191 x 81,5	<b>SECTOR</b> Ht 96 Dpt 197 W 92 102 131	<b>PL59.01W</b>	191 x 81,5
<b>80</b> x 190														
<b>90</b> x 190 200	<b>PL40.45B</b>	191 x 91,5 201 x 91,5	<b>PK50.08A</b>	191 x 91,5 201 x 91,5	<b>P04.84K</b>	191 x 91,5 201 x 91,5	<b>P04.83D</b>	191 x 91,5 201 x 91,5	<b>P04.91X</b>	191 x 91,5 201 x 91,5	<b>PL59.02C</b>	191 x 91,5 201 x 91,5		
<b>120</b> x 190 200	<b>PL40.46H</b>	191 x 121 201 x 121	<b>PK50.09G</b>	191 x 121 201 x 121	<b>P04.92C</b>	191 x 121 201 x 121					<b>PL59.03K</b>	191 x 121 201 x 121		
Custom-made beds Max W 205											<b>P49.98LP</b>	0,83 + 253,00		

**Fitted with 2<sup>nd</sup> base W 80 and slatted base**  
For the 2<sup>nd</sup> bed base mattress Ht 17 max

Model	Code	internal dimensions	Model	Code	internal dimensions	Model	Code	internal dimensions	Model	Code	internal dimensions	Model	Code	internal dimensions
<b>POLDO</b> Ht 86 Dpt 200 W 98 108	<b>PL40.47Q</b>	194 x 81,5	<b>POLDO SOFT</b> Ht 90 Dpt 204 W 98 108	<b>PK50.10D</b>	194 x 81,5	<b>R SCHEMA</b> Ht 86 Dpt 200 W 88,4 98,4	<b>P04.78B</b>	194 x 81,5	<b>L SCHEMA</b> Ht 86 Dpt 200 W 88,4 98,4	<b>P04.77W</b>	194 x 81,5	<b>SECTOR</b> Ht 96 Dpt 200 W 92 102	<b>PL59.04R</b>	194 x 81,5
<b>80</b> x 190														
<b>90</b> x 190	<b>PL40.48W</b>	194 x 91,5	<b>PK50.11L</b>	194 x 91,5	<b>P04.86V</b>	194 x 91,5	<b>P04.85Q</b>	194 x 91,5	<b>P04.85Q</b>	194 x 91,5	<b>PL59.05X</b>	194 x 91,5		
													<b>PL40.11K</b>	194 x 81,5
													<b>PL41.11P</b>	194 x 91,5

**Fitted with big drawers and slatted base**

Model	Code	internal dimensions	Model	Code	internal dimensions	Model	Code	internal dimensions	Model	Code	internal dimensions	Model	Code	internal dimensions
<b>POLDO</b> Ht 86 Dpt 200 W 98 108	<b>PL40.49C</b>	194 x 81,5	<b>POLDO SOFT</b> Ht 90 Dpt 204 W 98 108	<b>PK50.12S</b>	194 x 81,5				<b>SECTOR</b> Ht 96 Dpt 200 W 93,5 103,5	<b>PL59.06D</b>	194 x 81,5			
<b>80</b> x 190 ONE matte glossy CLUB														<b>PL40.12R</b>
<b>90</b> x 190 ONE matte glossy CLUB	<b>PL40.50Z</b>	194 x 91,5	<b>PK50.13Y</b>	194 x 91,5						<b>PL59.07L</b>	194 x 91,5			<b>PL41.12V</b>

**Fitted with slatted LIFTABLE base**  
Space inside container  
Ht 19,5 - Dpt 197 - W 83/123

Model	Code	internal dimensions	Model	Code	internal dimensions	Model	Code	internal dimensions	Model	Code	internal dimensions	Model	Code	internal dimensions
<b>POLDO</b> Specify R or L (drawing shows R) Ht 86 Dpt 200 W 98	<b>PL40.53U</b>	195 x 80	<b>POLDO SOFT</b> Specify R or L (drawing shows R) Ht 90 Dpt 204 W 98	<b>PK50.14E</b>	195 x 80	<b>R SCHEMA</b> Ht 86 Dpt 200 W 88,4	<b>PL40.58B</b>	195 x 80	<b>L SCHEMA</b> Ht 86 Dpt 200 W 88,4	<b>PL40.57V</b>	195 x 80	<b>SECTOR</b> Specify R or L (drawing shows R) Ht 96 Dpt 200 W 92	<b>PL59.08S</b>	195 x 80
<b>80</b> x 190														<b>PL40.54A</b>
<b>120</b> x 190														

- Components in **GROUP 2 colors**
- Components in **Types and colors FRONT**
- Padded components with not removable covers.

- \* When ordering, it is essential to state the width and depth of base. Base to be supplied by the customer.
- Shaped components available with contrasting edging.
- The headboard and foot panel can be two-coloured.



# Single beds with ATLANTE bed frame

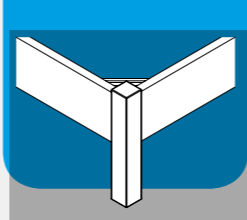

## Without base

Only the bed base without feet can be installed

### ATLANTE

Ht 34  
Dpt 203  
213  
W 90  
100  
129

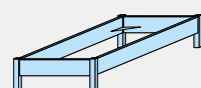

### COSY

Ht 100  
Dpt 207,5  
217,5  
W -  
108,5  
138

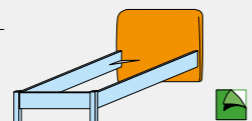

### CUFFIA

Ht 97  
Dpt 201,5  
211,5  
W -  
106  
136

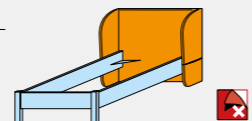

### ELFO

Ht 75  
Dpt 200  
210  
W 90  
100  
129

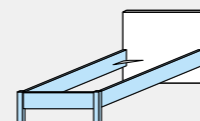

### R GIANO

Ht 82  
Dpt 200  
210  
W 90  
100  
-

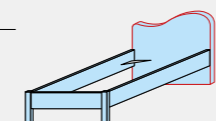

### L GIANO

Ht 82  
Dpt 200  
210  
W 90  
100  
-

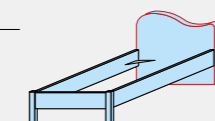

### HOLE

Ht 86,5  
Dpt 200  
210  
W 90  
100  
129,2

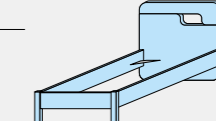

bed base W	Code	internal dimensions	Code	internal dimensions	Code	internal dimensions	Code	internal dimensions	Code	internal dimensions	Code	internal dimensions	
80 x 190	P43.10N	328,00 194,5 x 81,5	-	-	-	-	PL49.25E	192,5 x 81,5	P43.12Y	192,5 x 81,5	P43.11T	192,5 x 81,5	
90 x 190 200	P41.84H	194,5 x 91,5 204,5 x 91,5	PK50.15M	192,5 x 91,5 202,5 x 91,5	PK53.00M	192,5 x 91,5 202,5 x 91,5	PL41.51L	192,5 x 91,5 202,5 x 91,5	P43.63A	192,5 x 91,5 202,5 x 91,5	P43.62V	192,5 x 91,5 202,5 x 91,5	
120 x 190 200	P47.96T	194,5 x 121 204,5 x 121	PK50.16T	192,5 x 121 202,5 x 121	PK53.01T	192,5 x 121 202,5 x 121	PL42.30X	192,5 x 121 202,5 x 121	-	-	-	PL42.06V	192,5 x 121 202,5 x 121
Custom-made beds Max W 205	P65.99GP	per cm fixed charge	-	-	-	-	PL49.87AP	-	-	-	-	-	

## Fitted with 2<sup>nd</sup> base W 80 and slatted base

For the 2<sup>nd</sup> bed base mattress Ht 17 max

### ATLANTE

Ht 34  
Dpt 206  
W 90  
100

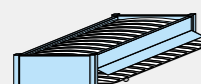

### ELFO

Ht 75  
Dpt 203  
W 90  
100

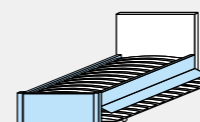

### R GIANO

Ht 82  
Dpt 203  
W 90  
100

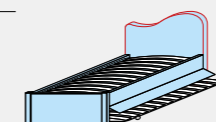

### L GIANO

Ht 82  
Dpt 203  
W 90  
100

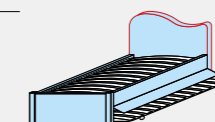

### HOLE

Ht 86,5  
Dpt 203  
W 90  
100

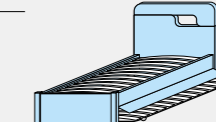

bed base W	Code	internal dimensions	Code	internal dimensions	Code	internal dimensions	Code	internal dimensions	Code	internal dimensions		
80 x 190	P43.68C	197,5 x 81,5					PL49.28Z	195,5 x 81,5	P43.70P	195,5 x 81,5	P43.69H	195,5 x 81,5
90 x 190	P42.54Y	197,5 x 91,5					PL41.53Y	195,5 x 91,5	P42.56K	195,5 x 91,5	P42.55D	195,5 x 91,5

## Fitted with big drawers and slatted base

### ATLANTE

Ht 34  
Dpt 206  
W 91  
101

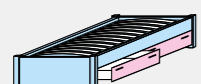

### ELFO

Ht 75  
Dpt 203  
W 91  
101

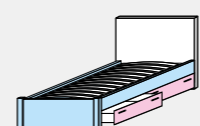

### R GIANO

Ht 82  
Dpt 203  
W 91  
101

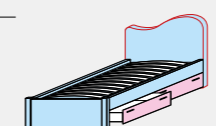

### L GIANO

Ht 82  
Dpt 203  
W 91  
101

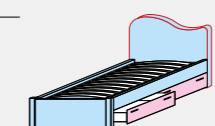

### HOLE

Ht 86,5  
Dpt 203  
W 90,5  
101

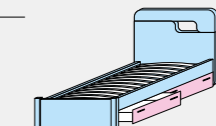

bed base W	Code	internal dimensions	Code	internal dimensions	Code	internal dimensions	Code	internal dimensions	Code	internal dimensions		
80 x 190 ONE matte glossy CLUB	P43.76W	197,5 x 81,5					PL49.31K	195,5 x 81,5	P43.78G	195,5 x 81,5	P43.77B	195,5 x 81,5
90 x 190 ONE matte glossy CLUB	P42.68Z	197,5 x 91,5					PL41.55M	195,5 x 91,5	P42.70L	195,5 x 91,5	P42.69E	195,5 x 91,5

## Fitted with slatted LIFTABLE base

Space inside container  
Ht 19,5 - Dpt 197 - W 83/123

### ATLANTE

Ht 34  
Dpt 204  
W 90  
100  
129

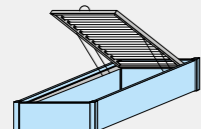

### COSY

Ht 100  
Dpt 210,5  
W -  
108,5  
138

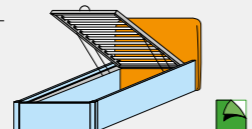

### ELFO

Ht 75  
Dpt 203  
W 90  
100  
129

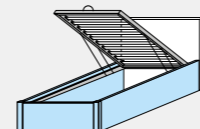

### R GIANO

Ht 82  
Dpt 203  
W 90  
100  
-

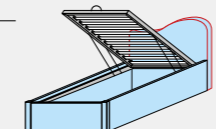

### L GIANO

Ht 82  
Dpt 203  
W 90  
100  
-

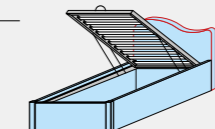

### HOLE

Ht 86,5  
Dpt 203  
W 90  
100  
-

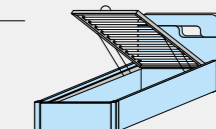

bed base W	Code	internal dimensions	Code	internal dimensions	Code	internal dimensions	Code	internal dimensions	Code	internal dimensions		
80 x 190	P47.21L	190 x 80	-	-	-	-	PL42.78W	190 x 80	P47.26N	190 x 80	P47.25G	190 x 80
90 x 190	PK53.02Z	190 x 90	PK53.03F	190 x 90			PK53.04N	190 x 90	PK53.05U	190 x 90	PK53.06A	190 x 90
120 x 190	P47.29D	190 x 120	PK52.32M	190 x 120			PL42.81F	190 x 120	-	-	-	-

- Components in **CARCASE** colors
- Components in **GROUP 2** colors
- Components in **Types and colors FRONT**
- Padded components with removable covers.
- Padded components with not removable covers.

- \* When ordering, it is essential to state the width and depth of base. Base to be supplied by the customer.
- Shaped components available with contrasting edging.
- The headboard and foot panel can be two-coloured.

FABRIC JENNY	0402	0403	0503	0900	0903	0905	0314	0303	0805	0706	0704	0601	0604
FABRIC KENYA	0014	0013	0016	0020	0019								
FALUX LEATHER TAPE	0111	0102	0603	0415	0503	0605	0700	0608	0901				

Mattresses, pillows and slatted bed base  
See back cover wing



# Single beds with ATLANTE bed frame

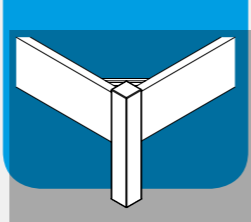

## Without base

Only the bed base without feet can be installed

	LOVE	NORMALE	NUBE	POLDO	POLDO SOFT	ROOF	R SCHEMA	
	Ht 86,5 Dpt 200 210 W 90 100 129,2	Ht 86,5 Dpt 200 210 W 90 100 129,2	Ht 79 Dpt 200 - W 90 - -	Ht 86 Dpt 200 210 W 98 108 137,5	Ht 86 Dpt 200 210 W 98 108 137,5	Ht 90 Dpt 204 214 W 98 108 137,5	Ht 102 Dpt 200 210 W 91,7 101,7 131,1	Ht 86 Dpt 200 210 W 90 100 129,5
bed base W	Code	internal dimensions	Code	internal dimensions	Code	internal dimensions	Code	internal dimensions
80 x 190	PL40.16S	192,5 x 81,5	PL49.26M	192,5 x 81,5	PL40.59H	192,5 x 81,5	PK50.26Y	192,5 x 81,5
90 x 190 200	PL41.16W	192,5 x 91,5 202,5 x 91,5	-	-	PL40.60E	192,5 x 91,5 202,5 x 91,5	PK50.18F	192,5 x 91,5 202,5 x 91,5
120 x 190 200	PL42.04G	192,5 x 121 202,5 x 121	-	-	PL40.61M	192,5 x 121 202,5 x 121	PK50.19N	192,5 x 121 202,5 x 121
Custom-made beds Max W 205	per cm fixed charge	-	-	-	-	-	-	-

## Fitted with 2<sup>nd</sup> base W 80 and slatted base

For the 2<sup>nd</sup> bed base mattress Ht 17 max

	LOVE	NORMALE	NUBE	POLDO	POLDO SOFT	ROOF	R SCHEMA	
	Ht 86,5 Dpt 203 W 90 100	Ht 86,5 Dpt 203 W 90 100	Ht 79 Dpt 203 W 90 -	Ht 86 Dpt 203 W 98 108	Ht 86 Dpt 203 W 98 108	Ht 90 Dpt 207 W 98 108	Ht 102 Dpt 203 W 91,7 101,7	Ht 86 Dpt 203 W 90 100
bed base W	Code	internal dimensions	Code	internal dimensions	Code	internal dimensions	Code	internal dimensions
80 x 190	PL40.17Y	195,5 x 81,5	PL49.29F	195,5 x 81,5	PL40.62T	195,5 x 81,5	PK50.29T	195,5 x 81,5
90 x 190	PL41.17C	195,5 x 91,5	-	-	PL40.63Z	195,5 x 91,5	PK50.21R	195,5 x 91,5

## Fitted with big drawers and slatted base

	LOVE	NORMALE	NUBE	POLDO	POLDO SOFT	ROOF	R SCHEMA		
	Ht 86,5 Dpt 203 W 90,5 101	Ht 86,5 Dpt 203 W 90,5 101	Ht 79 Dpt 203 W 91 -	Ht 86 Dpt 203 W 98 108	Ht 86 Dpt 203 W 98 108	Ht 90 Dpt 207 W 98 108	Ht 102 Dpt 203 W 91,7 101,7	Ht 86 Dpt 203 W 90 100	
bed base W	Code	internal dimensions	Code	internal dimensions	Code	internal dimensions	Code	internal dimensions	
80 x 190	ONE matte glossy CLUB	PL40.18E	195,5 x 81,5	PL49.32R	195,5 x 81,5	P43.79N	195,5 x 81,5	PL40.64F	195,5 x 81,5
90 x 190	ONE matte glossy CLUB	PL41.18K	195,5 x 91,5	-	-	P42.71R	195,5 x 91,5	PL40.65N	195,5 x 91,5

## Fitted with slatted LIFTABLE base

Space inside container  
Ht 19,5 - Dpt 197 - W 83/123

	LOVE	NORMALE	NUBE	POLDO	POLDO SOFT	ROOF	R SCHEMA	
	Ht 86,5 Dpt 203 W 90 100	Ht 86,5 Dpt 203 W 90 100	Ht 79 Dpt 203 W 90 -	Ht 86 Dpt 203 W 98 108 137,5	Ht 86 Dpt 203 W 98 108 137,5	Ht 90 Dpt 207 W 98 108 137,5	Ht 102 Dpt 203 W 91,7 101,7 131,1	Ht 86 Dpt 203 W 90 100 129,5
bed base W	Code	internal dimensions	Code	internal dimensions	Code	internal dimensions	Code	internal dimensions
80 x 190	PL40.39X	190 x 80	PL42.79C	190 x 80	P47.27T	190 x 80	PL40.66U	190 x 80
90 x 190	PK53.08P	190 x 90	-	-	PK53.10S	190 x 90	PK53.11Y	190 x 90
120 x 190	-	-	-	-	PL40.67A	190 x 120	PK50.25S	190 x 120

- Components in **CARCASE** colors
- Components in **GROUP 2** colors
- Components in **Types and colors FRONT**
- Padded components with not removable covers.

- \* When ordering, it is essential to state the width and depth of base. Base to be supplied by the customer.
- Shaped components available with contrasting edging.
- The headboard and foot panel can be two-coloured.



When ordering, specify for bed base Dpt 190 or 200.



# Single beds with ATLANTE bed frame

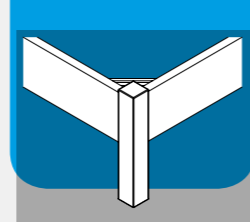

## Without base

Only the bed base without feet can be installed

### L SCHEMA

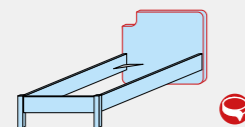

Ht 86  
Dpt 200  
210  
W 90  
100  
129,5

### SECTOR

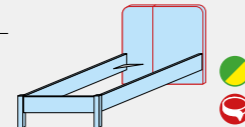

Ht 96  
Dpt 200  
210  
W 92  
102  
131

### SUMO

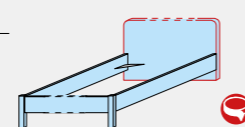

Ht 80  
Dpt 200  
-  
W 205  
MAX

### TWIST

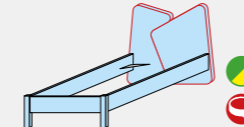

Ht 88  
Dpt 200  
210  
W 94  
104  
134

bed base W	Code	internal dimensions	Code	internal dimensions	Code	internal dimensions	Code	internal dimensions
80 x 190	P04.79G	192,5 x 81,5	PL59.09Y	192,5 x 81,5	-	-	PL40.22W	192,5 x 81,5
90 x 190 200	P04.87A	192,5 x 91,5 202,5 x 91,5	PL59.10V	192,5 x 91,5 202,5 x 91,5	-	-	PL41.22A	192,5 x 91,5 202,5 x 91,5
120 x 190 200	P04.93H	192,5 x 121 202,5 x 121	PL59.11B	192,5 x 121 202,5 x 121	-	-	PL42.08H	192,5 x 121 202,5 x 121
Custom-made beds Max W 205	per cm fixed charge	-	-	-	P65.96RP	-	-	-

### L SCHEMA

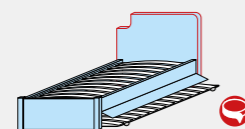

Ht 86  
Dpt 203  
W 90  
100

### SECTOR

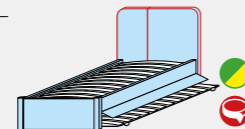

Ht 96  
Dpt 203  
W 92  
102

### TWIST

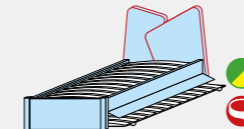

Ht 88  
Dpt 203  
W 94  
104

## Fitted with 2<sup>nd</sup> base W 80 and slatted base

For the 2<sup>nd</sup> bed base mattress Ht 17 max

bed base W	Code	internal dimensions	Code	internal dimensions	Code	internal dimensions
80 x 190	P04.81T	195,5 x 81,5	PL59.12H	195,5 x 81,5	PL40.23C	195,5 x 81,5
90 x 190	P04.89M	195,5 x 91,5	PL59.13Q	195,5 x 91,5	PL41.23G	195,5 x 91,5

### SECTOR

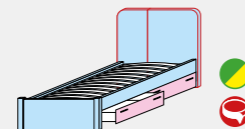

Ht 96  
Dpt 203  
W 93,5  
103,5

### TWIST

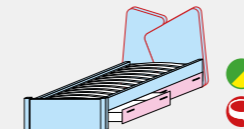

Ht 88  
Dpt 203  
W 94  
104

## Fitted with big drawers and slatted base

bed base W	Code	internal dimensions	Code	internal dimensions
80 x 190 ONE matte glossy CLUB	PL59.14W	195,5 x 81,5	PL40.24K	195,5 x 81,5
90 x 190 ONE matte glossy CLUB	PL59.15C	195,5 x 91,5	PL41.24P	195,5 x 91,5

### L SCHEMA

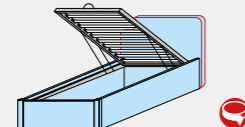

Ht 86  
Dpt 203  
W 90  
100  
129,5

### SECTOR

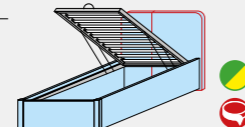

Ht 96  
Dpt 203  
W 92  
102  
131

### TWIST

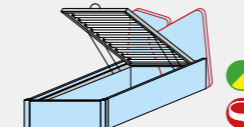

Ht 88  
Dpt 203  
W 94  
104

## Fitted with slatted LIFTABLE base

Space inside container  
Ht 19,5 - Dpt 197 - W 83/123

bed base W	Code	internal dimensions	Code	internal dimensions	Code	internal dimensions
80 x 190	P04.95U	190 x 80	PL59.16K	190 x 80	PL40.41A	190 x 80
90 x 190	PK53.14T	190 x 90	PK53.15Z	190 x 90	PK53.16F	190 x 90
120 x 190	P04.97E	190 x 120	PL59.17R	190 x 120	-	-

- Components in **GROUP 2 colors**
- Components in **Types and colors FRONT**

- \* When ordering, it is essential to state the width and depth of base. Base to be supplied by the customer.
- Shaped components available with contrasting edging.
- The headboard and foot panel can be two-coloured.



When ordering, specify for bed base Dpt 190 or 200.

# Single beds with GLOVE bed frame

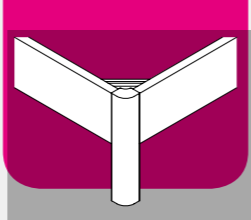

## Without base

Only the bed base without feet can be installed

COSY			CUFFIA			ELFO			R GIANO			L GIANO			GIOVE			HOLE					
Ht 100			Ht 100			Ht 97			Ht 75			Ht 82			Ht 82			Ht 32,5			Ht 86,5		
Dpt 207			Dpt 207			Dpt 201			Dpt 199,5			Dpt 199,5			Dpt 199,5			Dpt 202			Dpt 199,5		
217			217			211			209,5			209,5			209,5			212			209,5		
W -			W -			W -			W 90			W 90			W 90			W 90			W 90		
108,5			108,5			106			100			100			100			100			100		
138			138			136			129			-			-			128			129,2		
bed base W	Code	internal dimensions	Code	internal dimensions	Code	internal dimensions	Code	internal dimensions	Code	internal dimensions	Code	internal dimensions	Code	internal dimensions	Code	internal dimensions	Code	internal dimensions	Code	internal dimensions			
80 x 190	-	-	-	-	PL49.35L	192,5 x 81,5	-	-	PL49.40H	192,5 x 81,5	PL49.39M	192,5 x 81,5	PL49.37Y	195 x 81,5	PL49.70Z	192,5 x 81,5	-	-	-	-			
90 x 190	PK50.35X	192,5 x 91,5	PK53.17N	192,5 x 91,5	PL41.61R	192,5 x 91,5	-	-	PL41.65S	192,5 x 91,5	PL41.64L	192,5 x 91,5	PL41.63D	195 x 91,5	PL41.70Q	192,5 x 91,5	-	-	-	-			
		202,5 x 91,5		202,5 x 91,5		202,5 x 91,5				202,5 x 91,5		202,5 x 91,5		205 x 91,5		202,5 x 91,5							
120 x 190	PK50.36D	192,5 x 121	PK53.18U	192,5 x 121	PL42.33S	192,5 x 121	-	-	-	-	-	-	PL42.49M	195 x 121	PL42.39F	192,5 x 121	-	-	-	-			
		202,5 x 121		202,5 x 121		202,5 x 121								205 x 121		202,5 x 121							
Custom-made beds	*	per cm	-	-	PL49.88GP	-	-	-	-	-	-	-	PL49.92YP	-	-	-	-	-	-	-			
Max W 205		fixed charge	-	-																			

## Fitted with 2<sup>nd</sup> base W 80 and slatted base

For the 2<sup>nd</sup> bed base mattress Ht 17 max

ELFO			R GIANO			L GIANO			GIOVE			HOLE		
Ht 75			Ht 82			Ht 82			Ht 32,5			Ht 86,5		
Dpt 202,5			Dpt 202,5			Dpt 202,5			Dpt 205			Dpt 202,5		
W 90			W 90			W 90			W 90			W 90		
100			100			100			100			100		
bed base W	Code	internal dimensions	Code	internal dimensions	Code	internal dimensions	Code	internal dimensions	Code	internal dimensions	Code	internal dimensions	Code	internal dimensions
80 x 190	PL49.46X	195,5 x 81,5	PL49.51V	195,5 x 81,5	PL49.50P	195,5 x 81,5	PL49.48L	198 x 81,5	PL49.78B	195,5 x 81,5	-	-	-	-
90 x 190	PL41.72C	195,5 x 91,5	PL41.76D	195,5 x 91,5	PL41.75X	195,5 x 91,5	PL41.74R	198 x 91,5	PL41.81B	195,5 x 91,5	-	-	-	-

## Fitted with big drawers and slatted base

ELFO			R GIANO			L GIANO			GIOVE			HOLE		
Ht 75			Ht 82			Ht 82			Ht 32,5			Ht 86,5		
Dpt 202,5			Dpt 202,5			Dpt 202,5			Dpt 205			Dpt 202,5		
W 91			W 91			W 91			W 91			W 90,5		
101			101			101			101			101		
bed base W	Code	internal dimensions	Code	internal dimensions	Code	internal dimensions	Code	internal dimensions	Code	internal dimensions	Code	internal dimensions	Code	internal dimensions
80 x 190	ONE matte	195,5 x 81,5	PL49.57K	195,5 x 81,5	PL49.62G	195,5 x 81,5	PL49.61A	195,5 x 81,5	PL49.59X	198 x 81,5	PL49.84F	195,5 x 81,5	-	-
	glossy													
	CLUB													
90 x 190	ONE matte	195,5 x 91,5	PL41.83Q	195,5 x 91,5	PL41.87R	195,5 x 91,5	PL41.86K	195,5 x 91,5	PL41.85C	198 x 91,5	PL41.92P	195,5 x 91,5	-	-
	glossy													
	CLUB													

## Fitted with slatted LIFTABLE base

Space inside container  
Ht 19,5 - Dpt 197 - W 83/123

COSY			ELFO			R GIANO			L GIANO			GIOVE			HOLE		
Ht 100			Ht 75			Ht 82			Ht 82			Ht 32,5			Ht 86,5		
Dpt 210,5			Dpt 202,7			Dpt 202,7			Dpt 202,7			Dpt 202,7			Dpt 202,7		
W -			W 90			W 90			W 90			W 90			W 90		
108,5			100			100			100			100			100		
138			129			-			-			129			-		
bed base W	Code	internal dimensions	Code	internal dimensions	Code	internal dimensions	Code	internal dimensions	Code	internal dimensions	Code	internal dimensions	Code	internal dimensions			
80 x 190	-	-	PL42.85G	190 x 80	PL42.88B	190 x 80	PL42.87V	190 x 80	PL42.84A	190 x 80	PL42.93Z	190 x 80	-	-			
90 x 190	PK53.19A	190 x 90	PK53.20X	190 x 90	PK53.21D	190 x 90	PK53.22L	190 x 90	PK53.23S	190 x 90	PK53.24Y	190 x 90	-	-			
120 x 190	PK52.33T	190 x 120	PL49.94M	190 x 120	-	-	-	-	PL49.93E	190 x 120	-	-	-	-			

- Components in **CARCASE** colors
- Components in **GROUP 2** colors
- Components in **Types and colors FRONT**
- Padded components with removable covers.
- Padded components with not removable covers.

- \* When ordering, it is essential to state the width and depth of base. Base to be supplied by the customer.
- Shaped components available with contrasting edging.
- The headboard and foot panel can be two-coloured.



When ordering, specify for bed base Dpt 190 or 200.

# Single beds with GLOVE bed frame

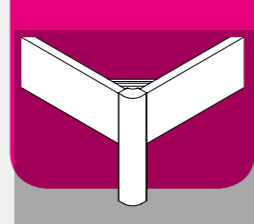

## Without base

Only the bed base without feet can be installed

	LOVE	NORMALE	NUBE	POLDO	POLDO SOFT	ROOF	R SCHEMA	
	Ht 86,5 Dpt 199,5 209,5 W 90 100 129,2	Ht 86,5 Dpt 199,5 209,5 W 90 100 129,2	Ht 79 Dpt 199,7 - W 90 -	Ht 86 Dpt 199,5 209,5 W 90 100 127,8	Ht 86 Dpt 199,5 209,5 W 98 108 137,5	Ht 90 Dpt 203,5 213,5 W 98 108 137,5	Ht 102 Dpt 199,5 209,5 W 91,7 101,7 131,1	Ht 86 Dpt 199,5 209,5 W 90 100 129,5
bed base W	Code	internal dimensions	Code	internal dimensions	Code	internal dimensions	Code	internal dimensions
80 x 190	PL49.69C	192,5 x 81,5	PL49.36S	192,5 x 81,5	PL40.70L	192,5 x 81,5	PK50.37L	192,5 x 81,5
90 x 190 200	PL41.69T	192,5 x 91,5 202,5 x 91,5	-	-	PL40.71S	192,5 x 91,5 202,5 x 91,5	PK50.38S	192,5 x 91,5 202,5 x 91,5
120 x 190 200	PL42.38Z	192,5 x 121 202,5 x 121	-	-	PL40.72Y	192,5 x 121 202,5 x 121	PK50.39Y	192,5 x 121 202,5 x 121
Custom-made beds Max W 205	per cm fixed charge	-	-	-	-	-	-	-

## Fitted with 2<sup>nd</sup> base W 80 and slatted base

For the 2<sup>nd</sup> bed base mattress Ht 17 max

	LOVE	NORMALE	NUBE	POLDO	POLDO SOFT	ROOF	R SCHEMA	
	Ht 86,5 Dpt 202,5 W 90 100	Ht 86,5 Dpt 202,5 W 90 100	Ht 79 Dpt 202,7 W 90 -	Ht 86 Dpt 202,5 W 90 100	Ht 86 Dpt 202,5 W 98 108	Ht 90 Dpt 206,5 W 98 108	Ht 102 Dpt 202,5 W 91,7 101,7	Ht 86 Dpt 202,5 W 90 100
bed base W	Code	internal dimensions	Code	internal dimensions	Code	internal dimensions	Code	internal dimensions
80 x 190	PL49.77V	195,5 x 81,5	PL49.47D	195,5 x 81,5	PL40.73E	195,5 x 81,5	PK50.40V	195,5 x 81,5
90 x 190	PL41.80V	195,5 x 91,5	-	-	PL40.74M	195,5 x 91,5	PK50.41B	195,5 x 91,5

## Fitted with big drawers and slatted base

	LOVE	NORMALE	NUBE	POLDO	POLDO SOFT	ROOF	R SCHEMA		
	Ht 86,5 Dpt 202,5 W 90,5 101	Ht 86,5 Dpt 202,5 W 90,5 101	Ht 79 Dpt 202,7 W 91 -	Ht 86 Dpt 202,5 W 91 101	Ht 86 Dpt 202,5 W 98 108	Ht 90 Dpt 206,5 W 98 108	Ht 102 Dpt 202,5 W 91,7 101,7	Ht 86 Dpt 202,5 W 90 100	
bed base W	Code	internal dimensions	Code	internal dimensions	Code	internal dimensions	Code	internal dimensions	
80 x 190	ONE matte glossy CLUB	PL49.83Z	195,5 x 81,5	PL49.58R	195,5 x 81,5	PL49.63P	195,5 x 81,5	PL40.75T	195,5 x 81,5
90 x 190	ONE matte glossy CLUB	PL41.91G	195,5 x 91,5	-	-	PL41.88X	195,5 x 91,5	PL40.76Z	195,5 x 91,5

## Fitted with slatted LIFTABLE base

Space inside container  
Ht 19,5 - Dpt 197 - W 83/123

	LOVE	NORMALE	NUBE	POLDO	POLDO SOFT	ROOF	R SCHEMA	
	Ht 86,5 Dpt 202,7 W 90 100	Ht 86,5 Dpt 202,7 W 90 100	Ht 79 Dpt 203 W 90 -	Ht 86 Dpt 202,7 W 90 100	Ht 86 Dpt 202,7 W 98 108 137,5	Ht 90 Dpt 206,7 W 98 108 137,5	Ht 102 Dpt 202,7 W 91,7 101,7 131,1	Ht 86 Dpt 202,7 W 90 100 129,5
bed base W	Code	internal dimensions	Code	internal dimensions	Code	internal dimensions	Code	internal dimensions
80 x 190	PL42.92T	190 x 80	PL42.86P	190 x 80	PL40.77F	190 x 80	PK50.44W	190 x 80
90 x 190	PK53.25E	190 x 90	-	-	PK53.27T	190 x 90	PK53.28Z	190 x 90
120 x 190	-	-	-	-	PL40.78N	190 x 120	PK50.45C	190 x 120

- Components in **CARCASE** colors
- Components in **GROUP 2** colors
- Components in **Types and colors FRONT**
- Padded components with not removable covers.

- \* When ordering, it is essential to state the width and depth of base. Base to be supplied by the customer.
- Shaped components available with contrasting edging.
- The headboard and foot panel can be two-coloured.



When ordering, specify for bed base Dpt 190 or 200.

# Single beds with GLOVE bed frame

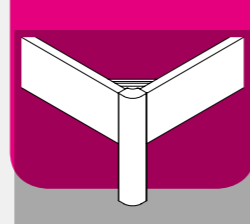

## Without base

Only the bed base without feet can be installed

### L SCHEMA

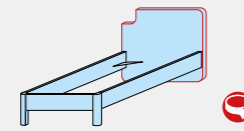

Ht 86  
Dpt 199,5  
209,5  
W 90  
100  
129,5

### SECTOR

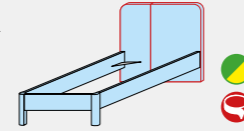

Ht 96  
Dpt 199,5  
209,5  
W 92  
102  
131

### SUMO

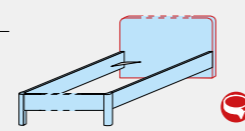

Ht 80  
Dpt 199,5  
-  
W 205  
MAX

### TWIST

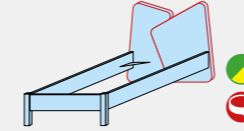

Ht 88  
Dpt 199,5  
209,5  
W 94  
104  
134

bed base W	Code	internal dimensions	Code	internal dimensions	Code	internal dimensions	Code	internal dimensions
80 x 190	PL49.72N	192,5 x 81,5	PL59.18X	192,5 x 81,5	-	-	PL49.71F	192,5 x 81,5
90 x 190 200	PL41.95H	192,5 x 91,5 202,5 x 91,5	PL59.19D	192,5 x 91,5 202,5 x 91,5	-	-	PL41.71W	192,5 x 91,5 202,5 x 91,5
120 x 190 200	PL42.50H	192,5 x 121 202,5 x 121	PL59.20A	192,5 x 121 202,5 x 121	-	-	PL42.40C	192,5 x 121 202,5 x 121
Custom-made beds Max W 205	*	per cm fixed charge	-	-	PL49.89PP	0,98 + 279,00	-	-

## Fitted with 2<sup>nd</sup> base W 80 and slatted base

For the 2<sup>nd</sup> bed base mattress Ht 17 max

### L SCHEMA

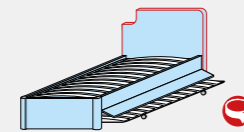

Ht 86  
Dpt 202,5  
W 90  
100

### SECTOR

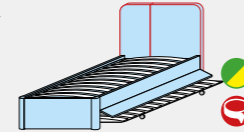

Ht 96  
Dpt 202,5  
W 92  
102

### TWIST

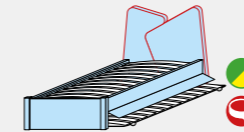

Ht 88  
Dpt 202,5  
W 94  
104

bed base W	Code	internal dimensions	Code	internal dimensions	Code	internal dimensions
80 x 190	PL49.80E	195,5 x 81,5	PL59.21G	195,5 x 81,5	PL49.79H	195,5 x 81,5
90 x 190	PL44.61D	195,5 x 91,5	PL59.22P	195,5 x 91,5	PL41.82H	195,5 x 91,5

## Fitted with big drawers and slatted base

### SECTOR

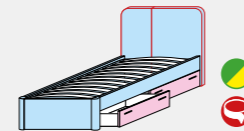

Ht 96  
Dpt 202,5  
W 93,5  
103,5

### TWIST

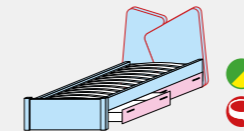

Ht 88  
Dpt 202,5  
W 94  
104

bed base W	Code	internal dimensions	Code	internal dimensions
80 x 190 ONE matte CLUB glossy	PL59.23V	195,5 x 81,5	PL49.85N	195,5 x 81,5
90 x 190 ONE matte CLUB glossy	PL59.24B	195,5 x 91,5	PL41.93V	195,5 x 91,5

## Fitted with slatted LIFTABLE base

Space inside container  
Ht 19,5 - Dpt 197 - W 83/123

### L SCHEMA

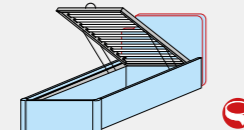

Ht 86  
Dpt 202,7  
W 90  
100  
129,5

### SECTOR

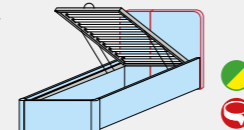

Ht 96  
Dpt 202,7  
W 92  
102

### TWIST

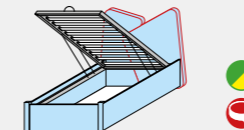

Ht 88  
Dpt 202,7  
W 94  
104

bed base W	Code	internal dimensions	Code	internal dimensions	Code	internal dimensions
80 x 190	PL42.94F	190 x 80	PL59.25H	190 x 80	PL42.89H	190 x 80
90 x 190	PK53.31K	190 x 90	PK53.32R	190 x 90	PK53.33X	190 x 90
120 x 190	PL49.95T	190 x 120	PL59.26Q	190 x 120	-	-

- Components in **GROUP 2 colors**
- Components in **Types and colors FRONT**

- \* When ordering, it is essential to state the width and depth of base. Base to be supplied by the customer.
- Shaped components available with contrasting edging.
- The headboard and foot panel can be two-coloured.





# Single beds with MARTE bed frame



## Without base

Only the bed base without feet can be installed

### COSY

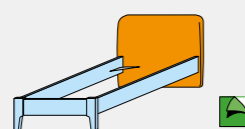

Ht 100  
Dpt 207  
217  
W 108,5  
138

### CUFFIA

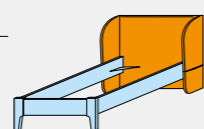

Ht 97  
Dpt 201  
211  
W 106  
136

### ELFO

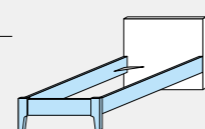

Ht 75  
Dpt 199,5  
209,5  
W 90  
100  
129

### R GIANO

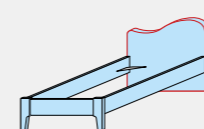

Ht 82  
Dpt 199,5  
209,5  
W 90  
100

### L GIANO

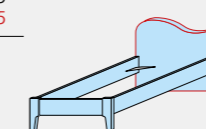

Ht 82  
Dpt 199,5  
209,5  
W 90  
100

### HOLE

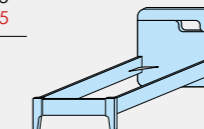

Ht 86,5  
Dpt 199,5  
209,5  
W 90  
100  
129,2

### LOVE

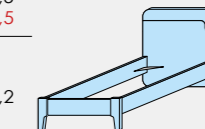

Ht 86,5  
Dpt 199,5  
209,5  
W 90  
100  
129,2

bed base W	Code	internal dimensions	Code	internal dimensions	Code	internal dimensions	Code	internal dimensions	Code	internal dimensions	Code	internal dimensions
80 x 190	-	-	-	-	PL40.84S	192,5 x 81,5	PL55.02L	192,5 x 81,5	PL55.00X	192,5 x 81,5	PL40.92K	192,5 x 81,5
90 x 190 200	PK50.55H	192,5 x 91,5 202,5 x 91,5	PK53.34D	192,5 x 91,5 202,5 x 91,5	PL40.85Y	192,5 x 91,5 202,5 x 91,5	PL55.03S	192,5 x 91,5 202,5 x 91,5	PL55.01D	192,5 x 91,5 202,5 x 91,5	PL40.93R	192,5 x 91,5 202,5 x 91,5
120 x 190 200	PK50.56Q	192,5 x 121 202,5 x 121	PK53.35L	192,5 x 121 202,5 x 121	PL56.31Z	192,5 x 121 202,5 x 121	-	-	-	-	PL56.34U	192,5 x 121 202,5 x 121
Custom-made beds Max W 205	per cm fixed charge	-	-	-	PL40.86E	-	-	-	-	-	-	-

## Without base

Only the bed base without feet can be installed

### MARTE

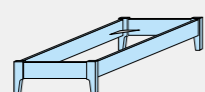

Ht 32,5  
Dpt 202  
212  
W 90  
100  
128

### NORMALE

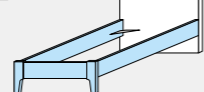

Ht 79  
Dpt 199,7  
-  
W 90  
-

### NUBE

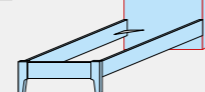

Ht 86  
Dpt 199,5  
209,5  
W 90  
100  
127,8

### POLDO

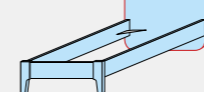

Ht 86  
Dpt 199,5  
209,5  
W 98  
108  
137,5

### POLDO SOFT

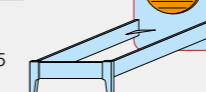

Ht 90  
Dpt 203,5  
213,5  
W 98  
108  
137,5

### ROOF

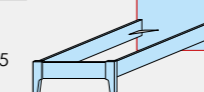

Ht 102  
Dpt 199,5  
209,5  
W 91,7  
101,7  
131,1

### R SCHEMA

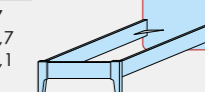

Ht 86  
Dpt 199,5  
209,5  
W 90  
100  
129,5

bed base W	Code	internal dimensions	Code	internal dimensions	Code	internal dimensions	Code	internal dimensions	Code	internal dimensions	Code	internal dimensions
80 x 190	PL40.81X	195 x 81,5	PL40.87M	192,5 x 81,5	PL40.95D	192,5 x 81,5	PL55.04Y	192,5 x 81,5	PK50.60F	192,5 x 81,5	PK50.57W	192,5 x 81,5
90 x 190 200	PL40.82D	195 x 91,5 205 x 91,5	-	-	PL40.96L	192,5 x 91,5 202,5 x 91,5	PL55.05E	192,5 x 91,5 202,5 x 91,5	PK50.61N	192,5 x 91,5 202,5 x 91,5	PK50.58C	192,5 x 91,5 202,5 x 91,5
120 x 190 200	PL56.30T	195 x 121 205 x 121	-	-	-	-	PL55.06M	192,5 x 121 202,5 x 121	PK50.62U	192,5 x 121 202,5 x 121	PK50.59K	192,5 x 121 202,5 x 121
Custom-made beds Max W 205	per cm fixed charge	PL40.83L	-	-	-	-	-	-	-	-	-	-

## Without base

Only the bed base without feet can be installed

### L SCHEMA

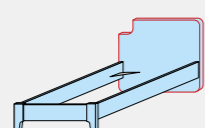

Ht 86  
Dpt 199,5  
209,5  
W 90  
100  
129,5

### SECTOR

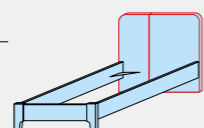

Ht 96  
Dpt 199,5  
209,5  
W 92  
102  
131

### SUMO

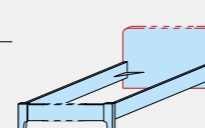

Ht 80  
Dpt 199,5  
-  
W 205  
MAX

### TWIST

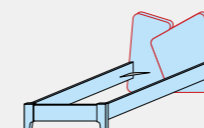

Ht 88  
Dpt 199,5  
209,5  
W 94  
104  
134

bed base W	Code	internal dimensions	Code	internal dimensions	Code	internal dimensions	Code	internal dimensions
80 x 190	PL55.09F	192,5 x 81,5	PL59.27W	192,5 x 81,5	-	-	PL40.88T	192,5 x 81,5
90 x 190 200	PL55.10C	192,5 x 91,5 202,5 x 91,5	PL59.28C	192,5 x 91,5 202,5 x 91,5	-	-	PL40.89Z	192,5 x 91,5 202,5 x 91,5
120 x 190 200	PL56.39B	192,5 x 121 202,5 x 121	PL59.29K	192,5 x 121 202,5 x 121	-	-	PL56.32F	192,5 x 121 202,5 x 121
Custom-made beds Max W 205	per cm fixed charge	-	-	PL55.15L	-	-	-	-

- Components in **CARCASE** colors
- Components in **GROUP 2** colors
- Padded components with removable covers.
- Padded components with not removable covers.

- \* When ordering, it is essential to state the width and depth of base. Base to be supplied by the customer.
- Shaped components available with contrasting edging.
- The headboard and foot panel can be two-coloured.



When ordering, specify for bed base Dpt 190 or 200.

# Single beds with NETTUNO bed frame

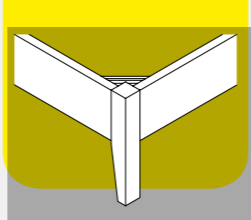

## Without base

Only the bed base without feet can be installed

### COSY

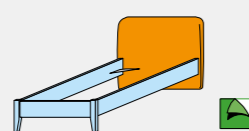

Ht 100  
Dpt 207  
217  
W 108,5  
138

### CUFFIA

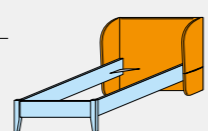

Ht 97  
Dpt 201  
211  
W 106  
136

### ELFO

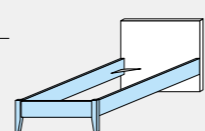

Ht 75  
Dpt 199,5  
209,5  
W 90  
100  
129

### R GIANO

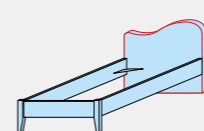

Ht 82  
Dpt 199,5  
209,5  
W 90  
100  
-

### L GIANO

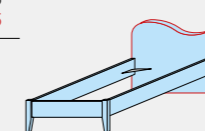

Ht 82  
Dpt 199,5  
209,5  
W 90  
100  
-

### HOLE

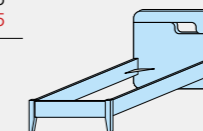

Ht 86,5  
Dpt 199,5  
209,5  
W 90  
100  
129,2

### LOVE

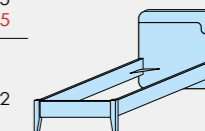

Ht 86,5  
Dpt 199,5  
209,5  
W 90  
100  
129,2

bed base W	Code	internal dimensions	Code	internal dimensions	Code	internal dimensions	Code	internal dimensions	Code	internal dimensions	Code	internal dimensions
80 x 190	-	-	-	-	PL55.23C	192,5 x 81,5	PL55.41A	192,5 x 81,5	PL55.39X	192,5 x 81,5	PL55.31V	192,5 x 81,5
90 x 190 200	PK50.63A	192,5 x 91,5 202,5 x 91,5	PK53.36S	192,5 x 91,5 202,5 x 91,5	PL55.24K	192,5 x 91,5 202,5 x 91,5	PL55.42G	192,5 x 91,5 202,5 x 91,5	PL55.40U	192,5 x 91,5 202,5 x 91,5	PL55.32B	192,5 x 91,5 202,5 x 91,5
120 x 190 200	PK50.64G	192,5 x 121 202,5 x 121	PK53.37Y	192,5 x 121 202,5 x 121	PL56.43T	192,5 x 121 202,5 x 121	-	-	-	-	PL56.46N	192,5 x 121 202,5 x 121
Custom-made beds Max W 205	per cm fixed charge	-	-	-	PL55.25R	-	-	-	-	-	-	-

## Without base

Only the bed base without feet can be installed

### NETTUNO

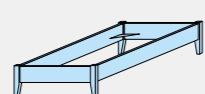

Ht 32,5  
Dpt 202  
212  
W 90  
100  
128

### NORMALE

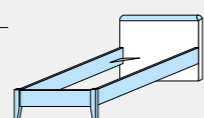

Ht 79  
Dpt 199,7  
-  
W 90  
-

### NUBE

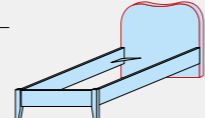

Ht 86  
Dpt 199,5  
209,5  
W 90  
100  
127,8

### POLDO

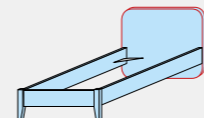

Ht 86  
Dpt 199,5  
209,5  
W 98  
108  
137,5

### POLDO SOFT

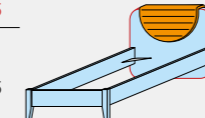

Ht 90  
Dpt 203,5  
213,5  
W 98  
108  
137,5

### ROOF

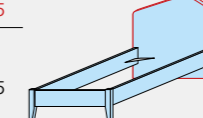

Ht 102  
Dpt 199,5  
209,5  
W 91,7  
101,7  
131,1

### R SCHEMA

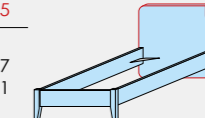

Ht 86  
Dpt 199,5  
209,5  
W 90  
100  
129,5

bed base W	Code	internal dimensions	Code	internal dimensions	Code	internal dimensions	Code	internal dimensions	Code	internal dimensions	Code	internal dimensions
80 x 190	PL55.20H	195 x 81,5	PL55.26X	192,5 x 81,5	PL55.34Q	192,5 x 81,5	PL55.43P	192,5 x 81,5	PK50.65P	192,5 x 81,5	PK50.68H	192,5 x 81,5
90 x 190 200	PL55.21Q	195 x 91,5 205 x 91,5	-	-	PL55.35W	192,5 x 91,5 202,5 x 91,5	PL55.44V	192,5 x 91,5 202,5 x 91,5	PK50.66V	192,5 x 91,5 202,5 x 91,5	PK50.69Q	192,5 x 91,5 202,5 x 91,5
120 x 190 200	PL56.42M	195 x 121 205 x 121	-	-	-	-	PL55.45B	192,5 x 121 202,5 x 121	PK50.67B	192,5 x 121 202,5 x 121	PK50.70M	192,5 x 121 202,5 x 121
Custom-made beds Max W 205	per cm fixed charge	PL55.22W	-	-	-	-	-	-	-	-	-	-

## Without base

Only the bed base without feet can be installed

### L SCHEMA

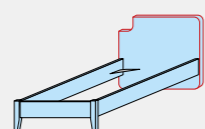

Ht 86  
Dpt 199,5  
209,5  
W 90  
100  
129,5

### SECTOR

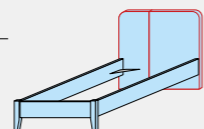

Ht 96  
Dpt 199,5  
209,5  
W 92  
102  
131

### SUMO

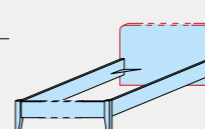

Ht 80  
Dpt 199,5  
-  
W 205  
MAX

### TWIST

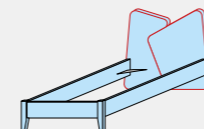

Ht 88  
Dpt 199,5  
209,5  
W 94  
104  
134

bed base W	Code	internal dimensions	Code	internal dimensions	Code	internal dimensions	Code	internal dimensions
80 x 190	PL55.48W	192,5 x 81,5	PL59.30F	192,5 x 81,5	-	-	PL55.27D	192,5 x 81,5
90 x 190 200	PL55.49C	192,5 x 91,5 202,5 x 91,5	PL59.31N	192,5 x 91,5 202,5 x 91,5	-	-	PL55.28L	192,5 x 91,5 202,5 x 91,5
120 x 190 200	PL56.51L	192,5 x 121 202,5 x 121	PL59.32U	192,5 x 121 202,5 x 121	-	-	PL56.44Z	192,5 x 121 202,5 x 121
Custom-made beds Max W 205	per cm fixed charge	-	-	PL55.55G	-	-	-	-

- Components in **CARCASE** colors
- Components in **GROUP 2** colors
- Padded components with removable covers.
- Padded components with not removable covers.

- \* When ordering, it is essential to state the width and depth of base. Base to be supplied by the customer.
- Shaped components available with contrasting edging.
- The headboard and foot panel can be two-coloured.

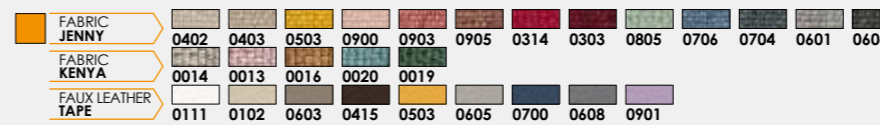

When ordering, specify for bed base Dpt 190 or 200.



# Single beds with SIGMA bed frame

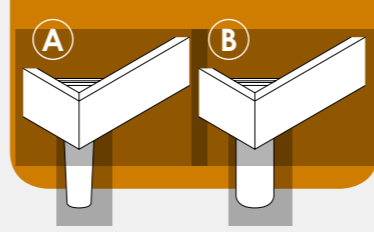

## Without base

Only the bed base without feet can be installed

### A With TWIG feet

#### COSY

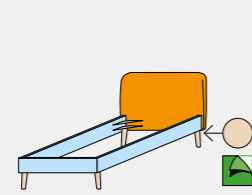

Ht 100  
Dpt 204,5  
W 108,5  
138

#### POLDO

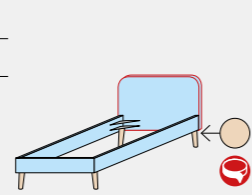

Ht 102  
Dpt 197  
W 101,7  
131,1

#### POLDO SOFT

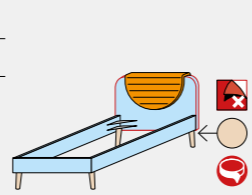

Ht 106  
Dpt 197  
W 101,7  
131,1

#### ROOF

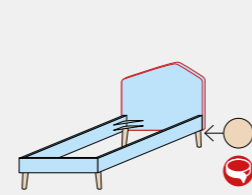

Ht 108,5  
Dpt 197  
W 101,7  
131,1

bed base W	Code	internal dimensions	Code	internal dimensions	Code	internal dimensions	Code	internal dimensions
90 x 190	PK50.71T	191 x 91,5	PK50.75U	191 x 91,5	PK50.79V	191 x 91,5	PK50.83M	191 x 91,5
120 190	PK50.72Z	191 x 121	PK50.76A	191 x 121	PK50.80S	191 x 121	PK50.84T	191 x 121

## Without base

Only the bed base without feet can be installed

### B With cylindrical feet

#### COSY

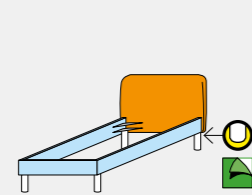

Ht 100  
Dpt 204,5  
W 108,5  
138

#### POLDO

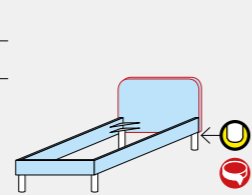

Ht 102  
Dpt 197  
W 101,7  
131,1

#### POLDO SOFT

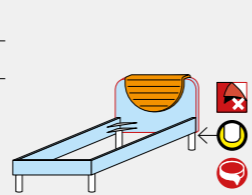

Ht 106  
Dpt 197  
W 101,7  
131,1

#### ROOF

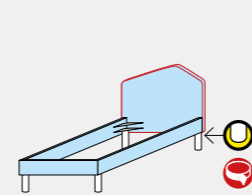

Ht 108,5  
Dpt 197  
W 101,7  
131,1

bed base W	Code	internal dimensions	Code	internal dimensions	Code	internal dimensions	Code	internal dimensions
90 x 190	PK50.73F	191 x 91,5	PK50.77G	191 x 91,5	PK50.81Y	191 x 91,5	PK50.85Z	191 x 91,5
120 190	PK50.74N	191 x 121	PK50.78P	191 x 121	PK50.82E	191 x 121	PK50.86F	191 x 121

- Components in **GROUP 2 colors**
- Padded components with removable covers.
- Padded components with not removable covers.
- Shaped components available with contrasting edging.

- Solid natural ash wood**  
Wood is a natural product and, as such, is subject to variations in color and grain. Differences in grain or color therefore do not constitute grounds for dispute.
- RW3Q RD5T CL1X B17A AL1A TR8A**

- FABRIC JENNY**  
0402 0403 0503 0900 0903 0905 0314 0303 0805 0706 0704 0601 0604
- FABRIC KENYA**  
0014 0013 0016 0020 0019
- FALUX LEATHER TAPE**  
0111 0102 0603 0415 0503 0605 0700 0608 0901



# Single beds with metal bed frame

**Ht 29**  
Complete with slatted base

With 4 feet

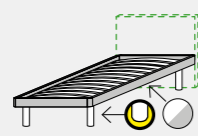

## COMPATIBLE WITH HEADBOARDS

With 4 castor wheels with brake

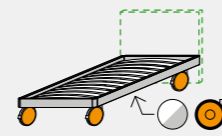

W	internal dimensions	Code	Code
193 x 88	189 x 84	H26.93P	P51.89N
193 x 98	189 x 94	H26.66S	P52.87E
193 x 128	189 x 124	H34.78C	P52.91B

**Ht 29**  
Complete with slatted base

With 2 feet and 2 castor wheels with brake (reversible)

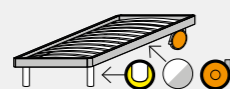

## NOT COMPATIBLE WITH HEADBOARDS

W	internal dimensions	Code
193 x 88	189 x 84	H26.94U
193 x 98	189 x 94	H26.67X
193 x 128	189 x 124	H34.80P

Add Dpt 193 to the depth of the chosen headboard to obtain the total depth of the bed. Headboards are raised above the ground.

Example of how to order a bed complete with headboard.

- 1) Choose the metal bed frame (example code H26.93P). State the colour (example Alluminio - AL1A).
- 2) State the foot colour (example Alluminio - AL1A).
- 3) Choose bed or ottoman headboard (example Normale bed headboard code P43.26Z colour Bianco opaco - B17A).
- 4) State the colour of the detail (example Agave - GV7A).

If a metal bed frame or a Somier with 2 feet and two wheels is selected, the application of headboards is NOT RECOMMENDED.

In the metal bed frame with 2 feet and 2 wheels, the feet and wheels may be installed as preferred (as shown).

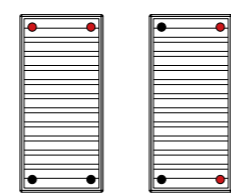
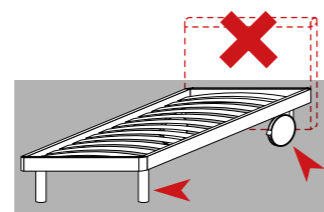
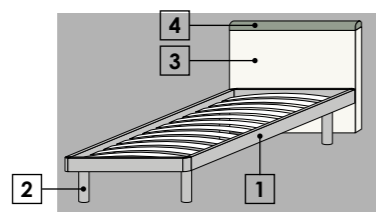

• Wheels  
• Feet

□ Components in **CARCASE** colors

□ Components in **GROUP 2** colors

▣ Padded components with not removable covers.

◌ Shaped components available with contrasting edging.

◌ The headboard and foot panel can be two-coloured.

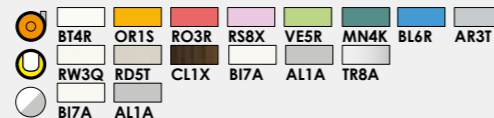

ELFO	ELFO	R GIANO	R GIANO	L GIANO
Ht 77	Ht 48	Ht 84	Ht 59	Ht 84
Dpt 3	Dpt 3	Dpt 3	Dpt 3	Dpt 3
W 90 100 129	W 90 100	W 90 100	W 90 100	W 90 100

**Headboards**  
Complete with fixing hardware.

for metal bed frame:	Code	Code	Code	Code	Code
193 x 88	P43.25U	P43.40A	P43.31B	P43.46H	P43.30W
193 x 98	P66.65A	P66.75E	P66.68S	P66.78W	P66.67M
193 x 128	P66.87V	-	-	-	-

L GIANO	HOLE	LOVE	NORMALE	NORMALE
Ht 59	Ht 88,5	Ht 88,5	Ht 81	Ht 49
Dpt 3	Dpt 3	Dpt 3	Dpt 3	Dpt 3
W 90 100	W 89 100 129,2	W 89 100 129,2	W 90	W 90

**Headboards**  
Complete with fixing hardware.

for metal bed frame:	Code	Code	Code	Code	Code
193 x 88	P43.45C	PL40.28L	PL40.27D	P43.26Z	P43.41F
193 x 98	P66.77R	PL41.28Q	PL41.27H	-	-
193 x 128	-	PL42.24T	PL42.23M	-	-

NUBE	POLDO	POLDO	POLDO SOFT	ROOF
Ht 88	Ht 88	Ht 58	Ht 92	Ht 104
Dpt 3	Dpt 3	Dpt 3	Dpt 6,5	Dpt 3
W 90 100	W 98 108 137,5	W 98 108	W 98 108 137,5	W 91,7 101,7 131,1

**Headboards**  
Complete with fixing hardware.

for metal bed frame:	Code	Code	Code	Code	Code
193 x 88	P43.32G	PL55.57V	H34.51F	PK50.87N	PK50.90X
193 x 98	P66.69X	PL55.58B	PL44.65E	PK50.88U	PK50.91D
193 x 128	-	PL55.59H	-	PK50.89A	PK50.92L

R SCHEMA	L SCHEMA	SECTOR	TWIST
Ht 88	Ht 88	Ht 98	Ht 90
Dpt 3	Dpt 3	Dpt 3	Dpt 3
W 88,4 98,4 127,8	W 88,4 98,4 127,8	W 92 102 131	W 94 104 134

**Headboards**  
Complete with fixing hardware.

for metal bed frame:	Code	Code	Code	Code
193 x 88	H04.76L	H04.75E	PL59.33A	PL40.26X
193 x 98	H04.84D	H04.83Y	PL59.34G	PL41.26B
193 x 128	H04.92X	H04.91S	PL59.35P	PL42.22E





# Single beds with somier

**Ht 29**  
Complete with slatted base

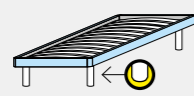
With 4 feet

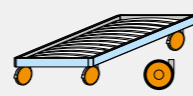

With 4 castor wheels with brake



W	internal dimensions	Code	Code
200 x 88	195 x 83	H26.61Q	P51.86W
200 x 98	195 x 93	H26.76W	P66.82T
200 x 128	195 x 123	-	P66.98E

**Ht 29**  
Complete with slatted base

With 2 feet and 2 castor wheels with brake (reversible)

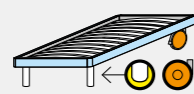

W	internal dimensions	Code	Code
200 x 88	195 x 83	H26.63A	
200 x 98	195 x 93	H26.78G	
200 x 128	195 x 123	H34.91Y	

## COMPATIBLE WITH HEADBOARDS

**Ht 29**  
Complete with slatted base

With 4 feet

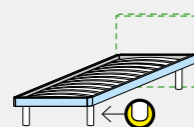

Prepared for the connection of the headboards.

With 4 castor wheels with brake

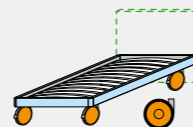

W	internal dimensions	Code	Code
198 x 88	195 x 83	H26.60K	P51.92D
198 x 98	195 x 93	H26.75R	P52.89R
198 x 128	195 x 123	H34.88G	H34.92D

Add Dpt 198 to the depth of the chosen headboard to obtain the total depth of the bed. Headboards are raised above the ground.

Example of how to order a bed complete with headboard.

- 1) Choose the Somier (example Code H26.60K colour Giallo zafferano - GZ8A).
- 2) State the foot colour (example Alluminio - AL1A).
- 3) Choose bed or ottoman headboard (example Normale bed headboard code P43.26Z colour Bianco opaco - B17A).
- 4) State the colour of the detail (example Agave - GV7A).

If a metal bed frame or a Somier with 2 feet and two wheels is selected, the application of headboards is NOT RECOMMENDED.

In the metal bed frame with 2 feet and 2 wheels, the feet and wheels may be installed as preferred (as shown).

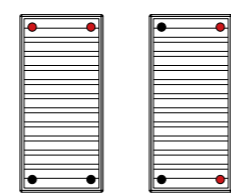
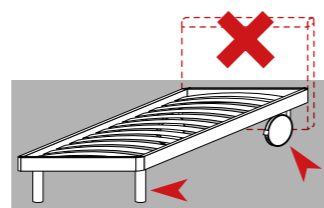
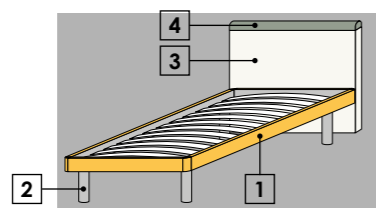

• Wheels  
• Feet

Components in **CARCASE** colors

Components in **GROUP 2** colors

Padded components with not removable covers.

Shaped components available with contrasting edging.

The headboard and foot panel can be two-coloured.

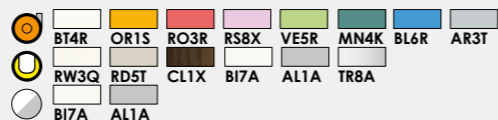

ELFO	ELFO	R GIANO	R GIANO	L GIANO
Ht 77	Ht 48	Ht 84	Ht 59	Ht 84
Dpt 3	Dpt 3	Dpt 3	Dpt 3	Dpt 3
W 90 100 129	W 90 100 -	W 90 100 -	W 90 100 -	W 90 100 -

**Headboards**  
Complete with fixing hardware.

for Somier:	Code	Code	Code	Code	Code
198 x 88	P43.25U	P43.40A	P43.31B	P43.46H	P43.30W
198 x 98	P66.65A	P66.75E	P66.68S	P66.78W	P66.67M
198 x 128	P66.87V	-	-	-	-

L GIANO	HOLE	LOVE	NORMALE	NORMALE
Ht 59	Ht 88,5	Ht 88,5	Ht 81	Ht 49
Dpt 3	Dpt 3	Dpt 3	Dpt 3	Dpt 3
W 90 100 -	W 89 100 129,2	W 89 100 129,2	W 90 -	W 90 -

**Headboards**  
Complete with fixing hardware.

for Somier:	Code	Code	Code	Code	Code
198 x 88	P43.45C	PL40.28L	PL40.27D	P43.26Z	P43.41F
198 x 98	P66.77R	PL41.28Q	PL41.27H	-	-
198 x 128	-	PL42.24T	PL42.23M	-	-

NUBE	POLDO	POLDO	POLDO SOFT	ROOF
Ht 88	Ht 88	Ht 58	Ht 92	Ht 104
Dpt 3	Dpt 3	Dpt 3	Dpt 6,5	Dpt 3
W 90 100 -	W 98 108 137,5	W 98 108 -	W 98 108 137,5	W 91,7 101,7 131,1

**Headboards**  
Complete with fixing hardware.

for Somier:	Code	Code	Code	Code	Code
198 x 88	P43.32G	PL55.57V	H34.51F	PK50.87N	PK50.90X
198 x 98	P66.69X	PL55.58B	PL44.65E	PK50.88U	PK50.91D
198 x 128	-	PL55.59H	-	PK50.89A	PK50.92L

R SCHEMA	L SCHEMA	SECTOR	TWIST
Ht 88	Ht 88	Ht 98	Ht 90
Dpt 3	Dpt 3	Dpt 3	Dpt 3
W 88,4 98,4 127,8	W 88,4 98,4 127,8	W 92 102 131	W 94 104 134

**Headboards**  
Complete with fixing hardware.

for Somier:	Code	Code	Code	Code
198 x 88	H04.76L	H04.75E	PL59.33A	PL40.26X
198 x 98	H04.84D	H04.83Y	PL59.34G	PL41.26B
198 x 128	H04.92X	H04.91S	PL59.35P	PL42.22E



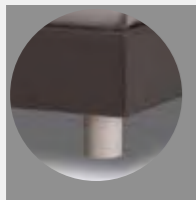

# Padded single beds



## Without base

Only the bed base without feet can be installed.  
Covers can be removed.

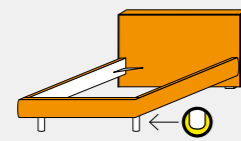
### LINE



Ht 101  
Dpt 207  
W -  
131

### NARCISO

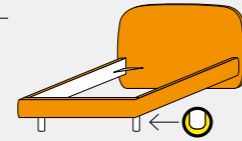

Ht 106  
Dpt 207  
W 113,5  
143

### REVERSO

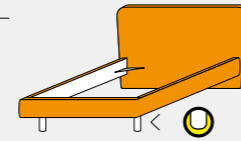

Ht 101  
Dpt 204  
W 122,5  
152

### SLIM

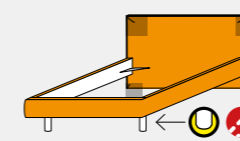

Ht 101  
Dpt 203  
W -  
135

### SNUG

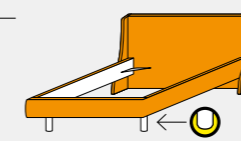

Ht 101  
Dpt 203  
W -  
149,5

### VERSO

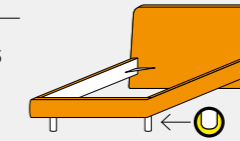

Ht 101  
Dpt 204  
W 114  
143,5

bed base W	Code	internal dimensions	Code	internal dimensions	Code	internal dimensions	Code	internal dimensions	Code	internal dimensions	Code	internal dimensions
90 x 190	-	-	PL55.76Z	194 x 91	PK51.05L	194 x 91	-	-	-	-	PK51.11Q	194 x 91
120 x 190	PK51.02R	194 x 121	PL55.77F	194 x 121	PK51.06S	194 x 121	PL55.73E	194 x 121	PL55.75T	194 x 121	PK51.12W	194 x 121

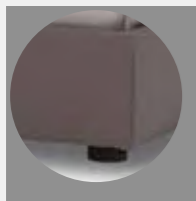

## Fitted with slatted LIFTABLE base

Space inside container  
Ht 19.5 - Dpt 197 - W 93/123.  
Covers can be removed.

### LINE

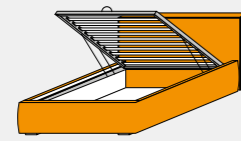

Ht 104,5  
Dpt 212  
W -  
131

### NARCISO

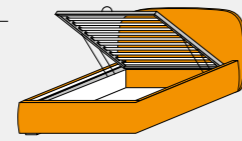

Ht 109,5  
Dpt 212  
W 113,5  
143

### REVERSO

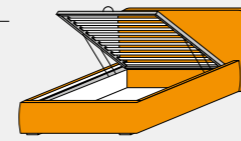

Ht 104,5  
Dpt 209  
W 122,5  
152

### SLIM

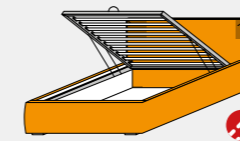

Ht 104,5  
Dpt 208  
W -  
135

### SNUG

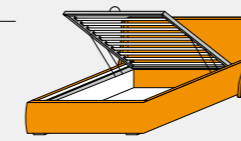

Ht 104,5  
Dpt 208  
W -  
149,5

### VERSO

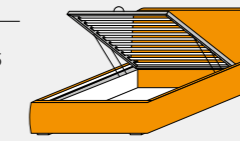

Ht 104,5  
Dpt 209  
W 114  
143,5

bed base W	Code	internal dimensions	Code	internal dimensions	Code	internal dimensions	Code	internal dimensions	Code	internal dimensions	Code	internal dimensions
90 x 190	-	-	PL55.81X	190 x 90	PK51.07Y	190 x 90	-	-	-	-	PK51.13C	190 x 90
120 x 190	PK51.03X	190 x 120	PL55.82D	190 x 120	PK51.08E	190 x 120	PL55.78N	190 x 120	PL55.80R	190 x 120	PK51.14K	190 x 120

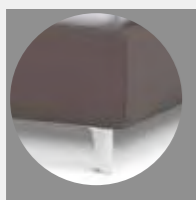

## Fitted with slatted LIFTABLE base

Space inside container  
Ht 19.5 - Dpt 197 - W 93/123.  
Covers can be removed.

### LINE

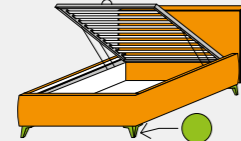

Ht 109,5  
Dpt 212  
W -  
131

### NARCISO

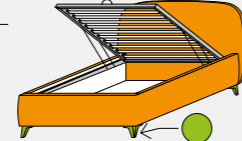

Ht 114,5  
Dpt 212  
W 113,5  
143

### REVERSO

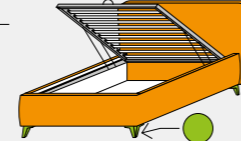

Ht 109,5  
Dpt 209  
W 122,5  
152

### SLIM

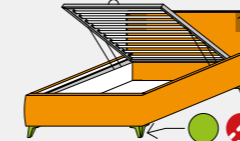

Ht 109,5  
Dpt 208  
W -  
135

### SNUG

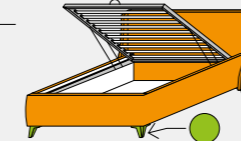

Ht 109,5  
Dpt 208  
W -  
149,5

### VERSO

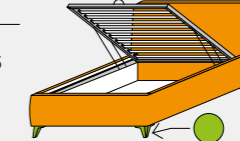

Ht 109,5  
Dpt 209  
W 114  
143,5

bed base W	Code	internal dimensions	Code	internal dimensions	Code	internal dimensions	Code	internal dimensions	Code	internal dimensions	Code	internal dimensions
90 x 190	-	-	PL58.85M	190 x 90	PK51.09M	190 x 90	-	-	-	-	PK51.15R	190 x 90
120 x 190	PK51.04D	190 x 120	PL58.86T	190 x 120	PK51.10H	190 x 120	PL58.88F	190 x 120	PL58.84E	190 x 120	PK51.16X	190 x 120

■ FABRIC JENNY 0402 0403 0503 0900 0903 0905 0314 0303 0805 0706 0704 0601 0604  
■ FABRIC KENYA 0014 0013 0016 0020 0019  
■ FALIX LEATHER TAPE 0111 0102 0603 0415 0503 0605 0700 0608 0901  
○ RW3Q RD5T CL1X B17A AL1A TR8A  
○ B17A GZ8T GV7A CQ3Q B14B BO7H CP4J RB7Y CR5T AL1A

Beds with contrasting seams.  
See the summary table at the top of the price list.





# Padded single beds ECOCHIC



With slatted base

## GALAXY



## GALLERY



## KANT

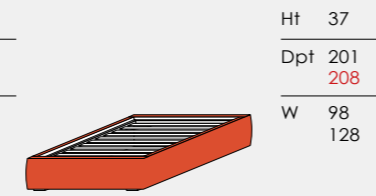

## KISS



## PAD



## TETRIS



## TWIN

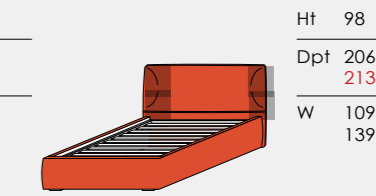

bed base W	Code	internal dimensions	Code	internal dimensions	Code	internal dimensions	Code	internal dimensions	Code	internal dimensions	Code	internal dimensions
90 x 190/200	PL55.85Y	195 x 92 202 x 92	PL55.83L	195 x 92 202 x 92	PL62.33Y	195 x 92 202 x 92	PL62.01U	195 x 92 202 x 92	PL55.93R	195 x 92 202 x 92	PL62.09W	195 x 92 202 x 92
120 x 190/200	PL55.86E	195 x 122 202 x 122	PL55.84S	195 x 122 202 x 122	PL62.34E	195 x 122 202 x 122	PL62.02A	195 x 122 202 x 122	PL55.94X	195 x 122 202 x 122	PL62.10T	195 x 122 202 x 122

## Fitted with slatted LIFTABLE base

Space inside container  
Ht 20 - Dpt 195 - W 92/122

## GALAXY



## GALLERY



## KANT

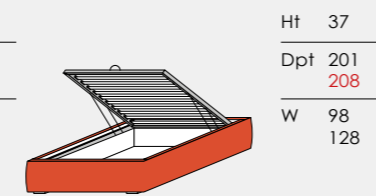

## KISS



## PAD

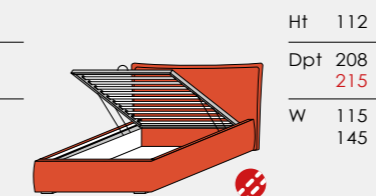

## TETRIS

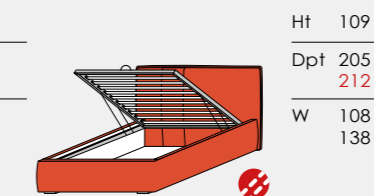

## TWIN

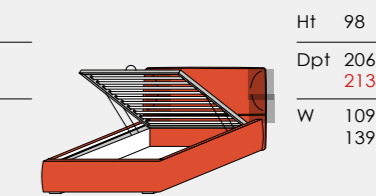

bed base W	Code	internal dimensions	Code	internal dimensions	Code	internal dimensions	Code	internal dimensions	Code	internal dimensions	Code	internal dimensions
90 x 190/200	PL55.90W	190 x 90 200 x 90	PL55.89Z	190 x 90 200 x 90	PL62.35M	190 x 90 200 x 90	PL62.03G	190 x 90 200 x 90	PL55.95D	190 x 90 200 x 90	PL62.11Z	190 x 90 200 x 90
120 x 190/200	PL55.91C	190 x 120 200 x 120	PL49.98N	190 x 120 200 x 120	PL62.36T	190 x 120 200 x 120	PL62.04P	190 x 120 200 x 120	PL55.96L	190 x 120 200 x 120	PL62.12F	190 x 120 200 x 120



With slatted base

## GALAXY



## GALLERY



## KANT

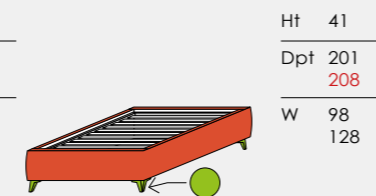

## KISS



## PAD



## TETRIS

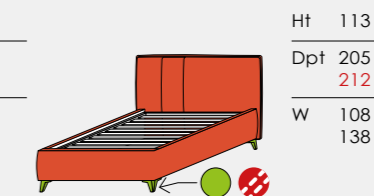

## TWIN

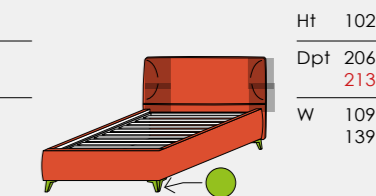

bed base W	Code	internal dimensions	Code	internal dimensions	Code	internal dimensions	Code	internal dimensions	Code	internal dimensions	Code	internal dimensions
90 x 190/200	PL62.17P	195 x 92 202 x 92	PL62.21E	195 x 92 202 x 92	PL62.37Z	195 x 92 202 x 92	PL62.05V	195 x 92 202 x 92	PL62.25F	195 x 92 202 x 92	PL62.13N	195 x 92 202 x 92
120 x 190/200	PL62.18V	195 x 122 202 x 122	PL62.22M	195 x 122 202 x 122	PL62.38F	195 x 122 202 x 122	PL62.06B	195 x 122 202 x 122	PL62.26N	195 x 122 202 x 122	PL62.14U	195 x 122 202 x 122

## Fitted with slatted LIFTABLE base

Space inside container  
Ht 20 - Dpt 195 - W 92/122

## GALAXY



## GALLERY

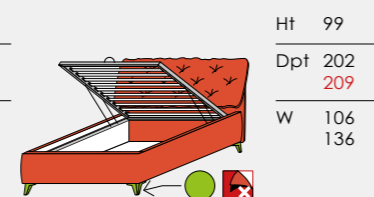

## KANT

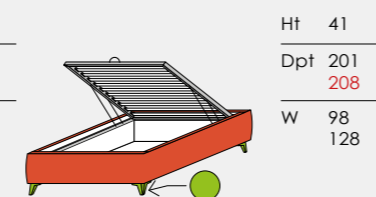

## KISS

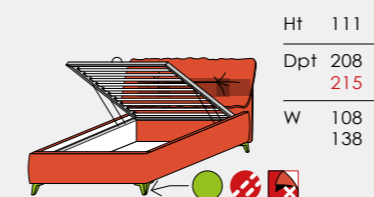

## PAD

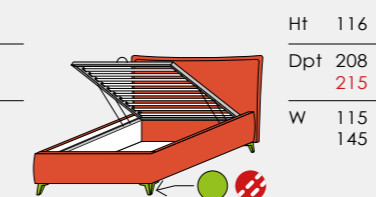

## TETRIS

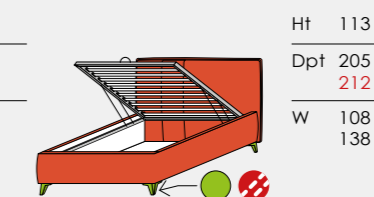

## TWIN

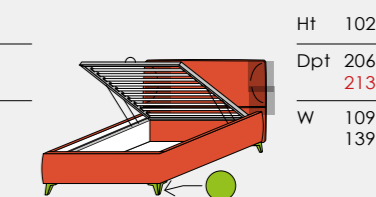

bed base W	Code	internal dimensions	Code	internal dimensions	Code	internal dimensions	Code	internal dimensions	Code	internal dimensions	Code	internal dimensions
90 x 190/200	PL62.19B	190 x 90 200 x 90	PL62.23T	190 x 90 200 x 90	PL62.39N	190 x 90 200 x 90	PL62.07H	190 x 90 200 x 90	PL62.27U	190 x 90 200 x 90	PL62.15A	190 x 90 200 x 90
120 x 190/200	PL62.20Y	190 x 120 200 x 120	PL62.24Z	190 x 120 200 x 120	PL62.40K	190 x 120 200 x 120	PL62.08Q	190 x 120 200 x 120	PL62.28A	190 x 120 200 x 120	PL62.16G	190 x 120 200 x 120

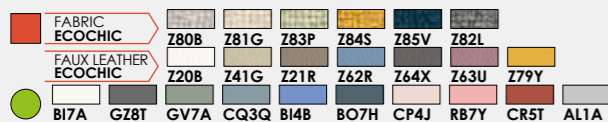

Beds with contrasting seams. See the summary table at the top of the price list.  
 Padded components with not removable covers.



When ordering, specify for bed base Dpt 190 or 200.

# Single ottomans with headboard and footboard



## Without base

ELFO		R GIANO		L GIANO		LOVE		NORMALE		NUBE		POLDO		
Ht 46		Ht 57		Ht 57		Ht 57		Ht 47		Ht 61		Ht 57		
Dpt 197		Dpt 197		Dpt 197		Dpt 197		Dpt 197		Dpt 197		Dpt 201		
W 90		W 90		W 90		W 89		W 90		W 90		W 98		
100		100		100		100		100		100		108		
bed base W	Code	internal dimensions	Code	internal dimensions	Code	internal dimensions	Code	internal dimensions	Code	internal dimensions	Code	internal dimensions	Code	internal dimensions
80 x 190	P41.15HP	191 x 81,5	P41.11M	191 x 81,5	P41.09A	191 x 81,5	PL40.29S	191 x 81,5	P42.03WP	191 x 81,5	P41.10F	191 x 81,5	P34.67Y	191 x 81,5
90 x 190	P41.42EP	191 x 91,5	P41.33F	191 x 91,5	P41.30Q	191 x 91,5	PL41.29W	191 x 91,5	-	-	P41.35S	191 x 91,5	P05.76U	191 x 91,5
200 x 190	P41.81SP	201 x 91,5	-	201 x 91,5	-	201 x 91,5	-	201 x 91,5	-	-	-	201 x 91,5	-	201 x 91,5
Custom-made beds	* per cm													
Max W 205	fixed charge													

## Fitted with 2<sup>nd</sup> base W 80 and slatted base

For the 2<sup>nd</sup> bed base mattress Ht 17 max

ELFO		R GIANO		L GIANO		LOVE		NORMALE		POLDO		
Ht 46		Ht 57		Ht 57		Ht 57		Ht 47		Ht 57		
Dpt 200		Dpt 200		Dpt 200		Dpt 200		Dpt 200		Dpt 200		
W 90		W 90		W 90		W 89		W 90		W 98		
100		100		100		100		-		108		
bed base W	Code	internal dimensions	Code	internal dimensions	Code	internal dimensions	Code	internal dimensions	Code	internal dimensions	Code	internal dimensions
80 x 190	P41.19E	194 x 81,5	P41.47G	194 x 81,5	P41.49T	194 x 81,5	PL40.30P	194 x 81,5	P44.55L	194 x 81,5	P34.68D	194 x 81,5
90 x 190	P41.44R	194 x 91,5	P41.98K	194 x 91,5	P41.97D	194 x 91,5	PL41.30T	194 x 91,5	-	-	P05.77Z	194 x 91,5

## Fitted with big drawers and slatted base

ELFO		R GIANO		L GIANO		LOVE		NORMALE		POLDO			
Ht 46		Ht 57		Ht 57		Ht 57		Ht 47		Ht 57			
Dpt 200		Dpt 200		Dpt 200		Dpt 200		Dpt 200		Dpt 200			
W 91		W 91		W 91		W 90,5		W 91		W 98			
101		101		101		101		-		108			
bed base W	Code	internal dimensions	Code	internal dimensions	Code	internal dimensions	Code	internal dimensions	Code	internal dimensions	Code	internal dimensions	
80 x 190	ONE matte glossy CLUB	P41.38H	194 x 81,5	P41.60C	194 x 81,5	P41.61H	194 x 81,5	PL40.31V	194 x 81,5	P44.58B	194 x 81,5	P34.69K	194 x 81,5
90 x 190	ONE matte glossy CLUB	P41.46B	194 x 91,5	P44.42Q	194 x 91,5	P44.40D	194 x 91,5	PL41.31Z	194 x 91,5	-	-	PL44.66M	194 x 91,5

## Fitted with slatted LIFTABLE base

Space inside container Ht 19,5 - Dpt 197 - W 83

ELFO		R GIANO		L GIANO		LOVE		NORMALE		
Ht 46		Ht 57		Ht 57		Ht 57		Ht 47		
Dpt 200		Dpt 200		Dpt 200		Dpt 200		Dpt 200		
W 90		W 90		W 90		W 89		W 90		
bed base W	Code	internal dimensions	Code	internal dimensions	Code	internal dimensions	Code	internal dimensions	Code	internal dimensions
80 x 190	P47.37X	195 x 80	PL55.97S	195 x 80	P47.42Z	195 x 80	PL40.42G	197 x 83	P47.38C	195 x 80

- Components in **CARCASE** colors
- Components in **GROUP 2** colors
- Components in **Types and colors FRONT**

- \* When ordering, it is essential to state the width and depth of base. Base to be supplied by the customer.
- ⊗ Shaped components available with contrasting edging.
- The headboard and foot panel can be two-coloured.





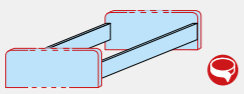
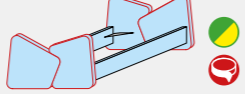

# Single ottomans with headboard and footboard

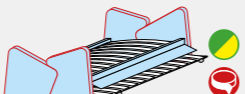

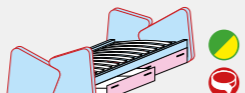
Without base		SUMO	TWIST						
				Ht 50 Dpt 197 W 205 MAX	Ht 58,5 Dpt 197 207 W 94 104				
bed base W	Code	internal dimensions	Code	internal dimensions					
80 x 190	-	-	PL40.32B	191 x 81,5					
90 x 190 200	-	-	PL41.32F	191 x 91,5 201 x 91,5					
Custom-made beds Max W 205	* per cm fixed charge	P53.02WP	-						

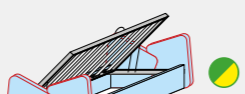
Fitted with 2 <sup>nd</sup> base W 80 and slatted base		TWIST							
			Ht 58,5 Dpt 200 W 94 104						
For the 2 <sup>nd</sup> bed base mattress Ht 17 max									
bed base W	Code	internal dimensions							
80 x 190	PL40.33H	194 x 81,5							
90 x 190	PL41.33N	194 x 91,5							

Fitted with big drawers and slatted base		TWIST							
			Ht 58,5 Dpt 200 W 94 104						
bed base W	Code	internal dimensions							
80 x 190	ONE matte CLUB glossy	PL40.34Q	194 x 81,5						
90 x 190	ONE matte CLUB glossy	PL41.34U	194 x 91,5						

Fitted with slatted LIFTABLE base		TWIST							
			Ht 58,5 Dpt 200 W 94						
Space inside container Ht 19,5 - Dpt 197 - W 83									
bed base W	Code	internal dimensions							
80 x 190	PL40.43P	195 x 80							

 Components in **GROUP 2 colors**  
 Components in **Types and colors FRONT**

- \* When ordering, it is essential to state the width and depth of base. Base to be supplied by the customer.
-  Shaped components available with contrasting edging.
-  The headboard and foot panel can be two-coloured.



# Sofa beds

## With slatted base

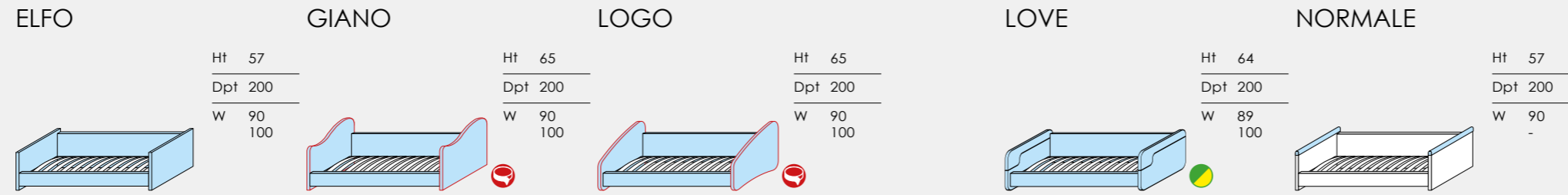

bed base W	Code	internal dimensions	Code	internal dimensions	Code	internal dimensions	Code	internal dimensions	Code	internal dimensions
80 x 190	P46.67G	194 x 81,5	P46.06A	194 x 81,5	P43.48U	194 x 81,5	PL40.35W	194 x 81,5	P46.21G	194 x 81,5
90 x 190	P41.48N	194 x 91,5	P46.59P	194 x 91,5	P46.00T	194 x 91,5	PL41.35A	194 x 91,5	-	-

## Fitted with 2<sup>nd</sup> base W 80 and slatted base

For the 2<sup>nd</sup> bed base mattress Ht 17 max.

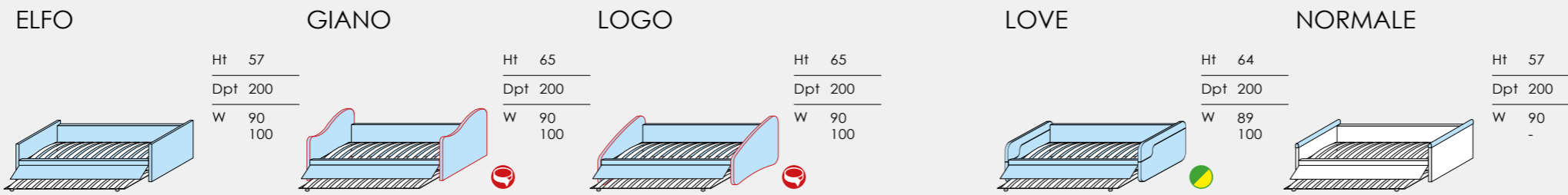

bed base W	Code	internal dimensions	Code	internal dimensions	Code	internal dimensions	Code	internal dimensions	Code	internal dimensions
80 x 190	P46.69T	194 x 81,5	P46.10X	194 x 81,5	P43.50E	194 x 81,5	PL40.36C	194 x 81,5	P46.23T	194 x 81,5
90 x 190	P41.50Y	194 x 91,5	P46.73Q	194 x 91,5	P46.63L	194 x 91,5	PL41.36G	194 x 91,5	-	-

## Fitted with big drawers and slatted base

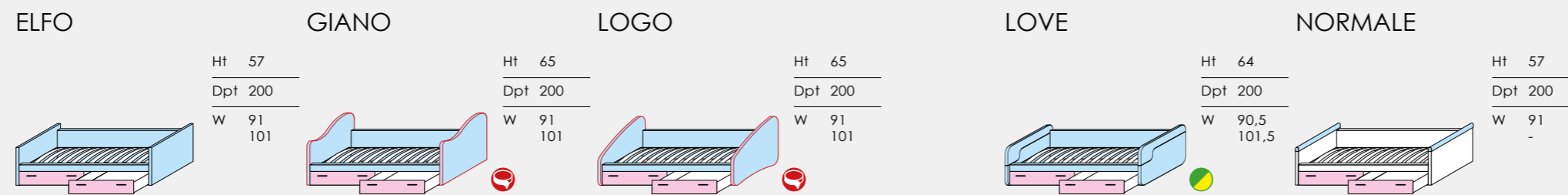

bed base W	Code	internal dimensions	Code	internal dimensions	Code	internal dimensions	Code	internal dimensions	Code	internal dimensions	
80 x 190	ONE matte	P46.71D	194 x 81,5	P46.38Z	194 x 81,5	P43.52R	194 x 81,5	PL40.37K	194 x 81,5	P46.25D	194 x 81,5
	CLUB glossy										
90 x 190	ONE matte	P41.52K	194 x 91,5	P46.75A	194 x 91,5	P46.65W	194 x 91,5	PL41.37P	194 x 91,5	-	-
	CLUB glossy										

Foam mattress without cover  
For upper base

Ht 12  
Dpt 196,5  
W 83



Code

P48.09Y

Foam mattress with cotton fabric  
For upper base

Ht 12  
Dpt 194  
W 83  
93



Code

PL55.98Y

Coverlet with elastic, in cotton fabric

Ht 12 / 17



Code

PL56.00B

Covered foam mattress  
For pull-out 2<sup>nd</sup> base.

Ht 12  
Dpt 189  
W 81,5



Code

P48.07N

Pair of pillows without covers

Ht 47  
Dpt 26  
W 210



Code

P45.00Q

Pair of pillows with cotton pillow cases

Ht 47  
Dpt 26  
W 210



Code

PL56.02Q

Pair of cotton pillow cases



Code

PL56.03W

Cotton fabric per cm Customised W

Ht 140  
W min. 40

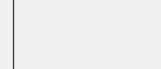

Code

PL56.04C

- Components in **CARCASE** colors
- Components in **GROUP 2** colors
- Components in **Types and colors FRONT**

- Shaped components available with contrasting edging.
- The headboard and foot panel can be two-coloured.

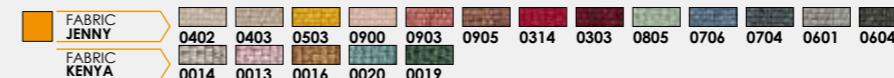

# Bed and sofa bed with second automatic lifting base

## Bed

With two slatted bases  
Lower base with wheels and Automatic lifting system (mattress H 12 max)

### POLDO

Ht 86  
Dpt 200  
W 98

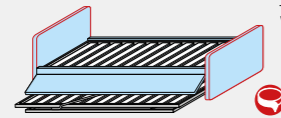

bed base W	Code	internal dimensions		
80 x 190	PL59.44N	190 x 80		

## Sofa beds

With two slatted bases  
Lower base with wheels and Automatic lifting system (mattress H 12 max)

### POLDO

Ht 86  
Dpt 200  
W 98

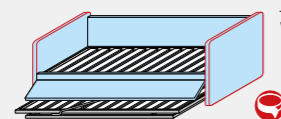

### SPAZIO

With fixed structural slatted base

Ht 85  
Dpt 200  
W 91

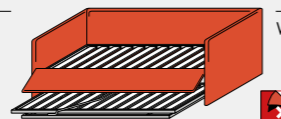

bed base W	Code	internal dimensions	Code	internal dimensions
80 x 190	PL59.45U	190 x 80	PL59.46A	190 x 80

## Slatted base with wheels and automatic lifting system

Ht 22 ÷ 35  
Dpt 186  
W 76

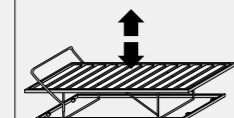

Mattress Ht 12 max.

Code	PL59.47G		

## Bed base with automatic lifting system

The bed base lifts by simply lifting the handle

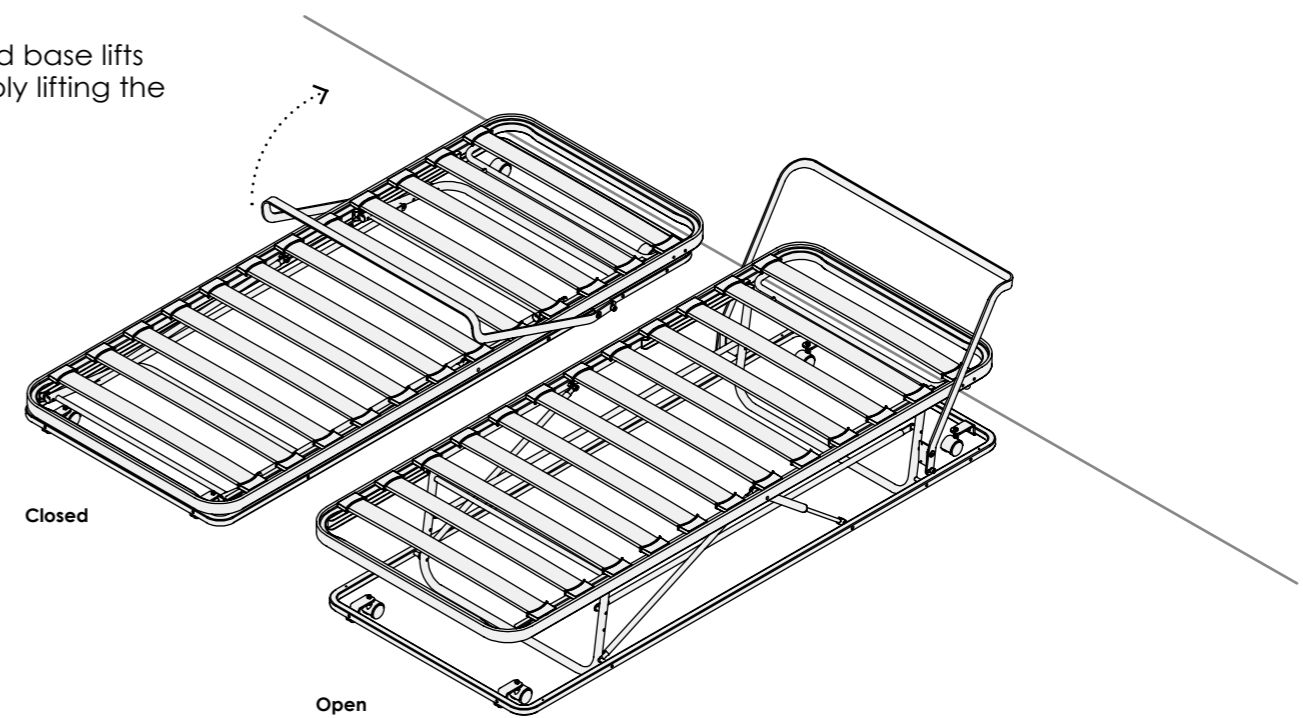

## Covered foam rubber mattress

For base with automatic lifting mechanism

Ht 12  
Dpt 185  
W 75



Code PL39.47A

## Mattress

For upper bed base

Ht 17  
Dpt 190  
W 80



Code PL39.00H

## Pillows

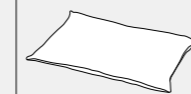

Code PL39.50L

## Slatted bed base with wheels and foldable feet

To be used as an alternative to the bed base with wheels and automatic lifting system

Ht 5 ÷ 30 Mattress Ht 17  
Dpt 190  
W 80



Code P48.53N

CAPRI	PL39.00H	PONZA	PL39.50L
LIPARI	PL39.02W	PROCIDA	PL39.51S
		MALVA	PL39.52Y

Components in GROUP 2 colors

Padded components with not removable covers.

Shaped components available with contrasting edging.



# BAIA sofa beds and desks

## BAIA sofa beds

Upholstered, smooth and quilted panels generate specific processing on the headboard, footboard and sides. The coverings are not removable. Size reductions are not permitted.

View from the headboard side

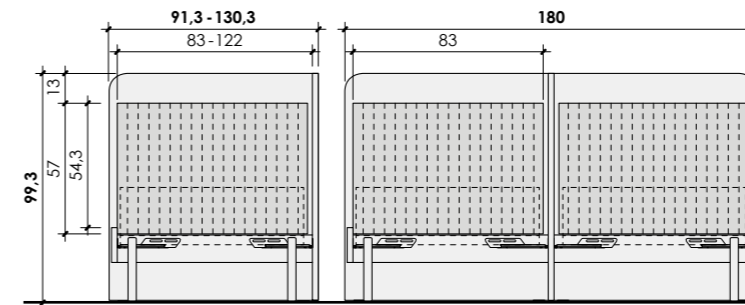

Side view

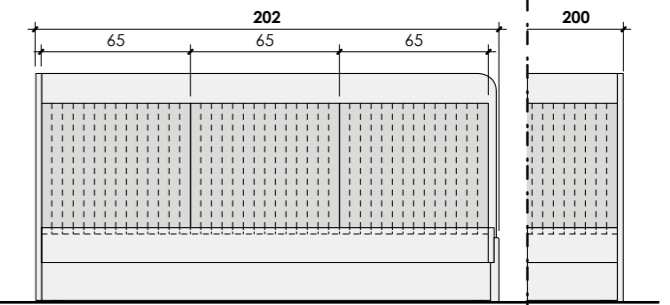

### Without base

Ht 99,3  
Dpt 200  
W 91,3  
internal dimensions: 194 x 84,2

Use the: mattress 190 x 80

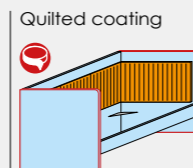
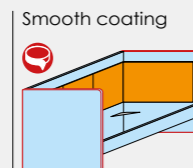
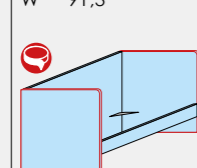

Code	PK53.38E	PK53.73U	PK53.39M
------	----------	----------	----------

### Fitted with 2<sup>nd</sup> base W 76 and slatted base

Ht 99,3  
Dpt 200  
W 91,3  
internal dimensions: 194 x 84,2

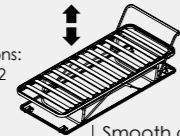

Lower base with wheels and automatic lifting system (mattress H 12 max)

#### Slatted bed base with wheels and foldable feet

Ht 5 ÷ 30  
Dpt 190  
W 80  
Mattress Ht 17  
To be used as an alternative to the bed base with wheels and automatic lifting system



#### Mattress

Ht 17  
Dpt 190  
W 80  
For upper bed base



#### Code

CAPRI	PL39.00H
LIPARI	PL39.02W

#### Covered foam rubber mattress

Ht 12  
Dpt 185  
W 75  
For base with automatic lifting mechanism



Code	PL39.47A
------	----------

### Fitted with big drawers and slatted base

Ht 99,3  
Dpt 200  
W 91,3  
internal dimensions: 194 x 84,2

Use the: mattress 190 x 80

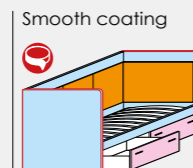
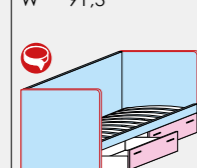

Ht 99,3  
Dpt 201  
W 91,3  
internal dimensions: 194 x 84,2  
Specify R or L (R drawings)

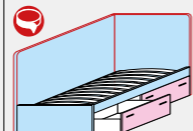

Use the: mattress 190 x 80



The big drawers are fixed to the structure by means of runners.  
The CLUB big drawers are equipped with "Quadro" type soft-close runners, supplied standard.

Code	PK53.42W	PK53.75G	PK53.43C	PK53.44K	PK53.76P	PK53.45R
ONE	matte					
	glossy					
CLUB						

### Without base, with foot

Ht 99,3  
Dpt 202  
W 91,3  
internal dimensions: 194 x 84,2  
Specify R or L (R drawings)

Use the: mattress 190 x 80

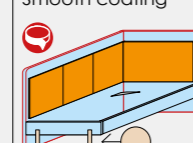
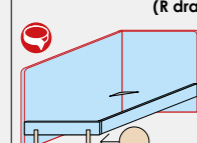

Ht 99,3  
Dpt 202  
W 130,3  
internal dimensions: 194 x 123,2  
Specify R or L (R drawings)

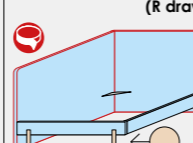

Use the: mattress 190 x 120

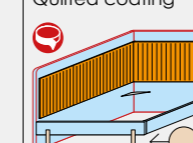

Ht 99,3  
Dpt 202  
W 180  
internal dimensions: 194 x 84,2

Use the: mattress 190 x 80

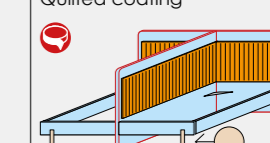
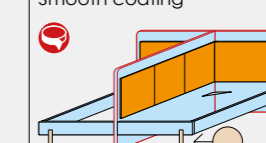
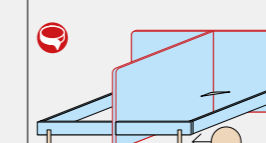

Code	PK53.46X	PK53.77V	PK53.47D	PK53.48L	PK53.78B	PK53.49S	PK53.54Q	PK53.79H	PK53.55W
------	----------	----------	----------	----------	----------	----------	----------	----------	----------

### Desks

Ht 99,3  
Dpt 60,8  
W 135

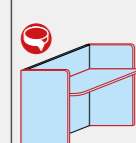

W 150

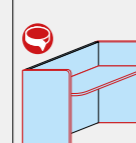

W 165

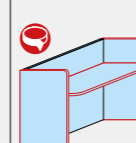

W 180

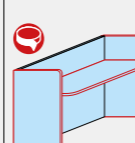

Code	PK53.50P	PK53.51V	PK53.52B	PK53.53H
------	----------	----------	----------	----------

#### Metal accessories for desk

##### Paper holder

Ht 5,2  
Dpt 21  
W 30



VAST  
BI4B  
CR5T

##### Pen holder

Ht 11  
Dpt 7,8  
W 7,5

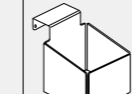

VAST  
BI4B  
CR5T

Code	PK47.27G	PK47.28P
------	----------	----------

#### BAIA desks

Entirely made up of Th 2.5 panels.

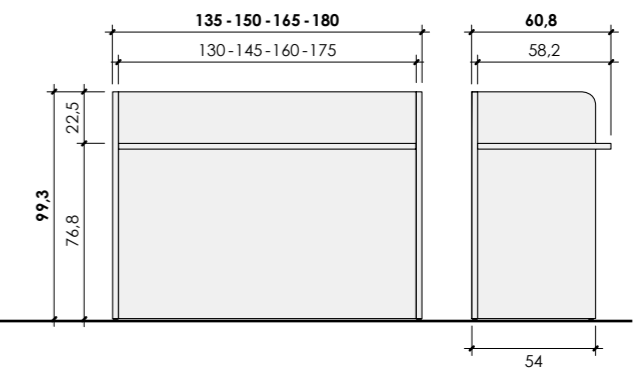

Components in GROUP 2 colors

Components in Types and colors FRONT

Solid natural ash wood

Wood is a natural product and, as such, is subject to variations in color and grain. Differences in grain or color therefore do not constitute grounds for dispute.

Shaped components available with contrasting edging.

FABRIC JENNY	0402	0403	0503	0900	0903	0905	0314	0303	0805	0706	0704	0601	0604
FABRIC KENYA	0014	0013	0016	0020	0019								
FALUX LEATHER TAPE	0111	0102	0603	0415	0503	0605	0700	0608	0901				

Mattresses, pillows and slatted bed base

See back cover wing

# Accessories for beds

## Side panels

Ht 15,2 Th 2,5 <b>With plates</b> For bed base without feet	Ht 15,2 Th 2,5 <b>Without plates</b> For bed base with feet
--	--

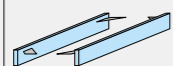

W	Code	Code	
192	P48.13V	P48.15F	
202	P35.56S	P35.55M	
Custom-made Max W 230	P48.57K	P48.51B	

## Feet and wheels

For Metal bed frame and Somier

<b>Pair of feet</b> Ht 23,7 Ø 8* * Ø 7 in the Trasparente (TR8A) version	<b>Pair of castor wheels with brake</b> Ht 23,7 Ø 15
---	--

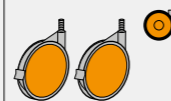
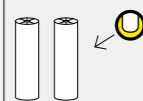

Code	H26.59D	P51.88G	

## Pair of big drawers

Ht 24 Dpt 61,9 W each 97,1
----------------------------------

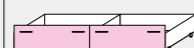

Code	P48.87X		
ONE	matte		
	glossy		
CLUB			

## Led light

For mounting on headboards

1,2 Watt - 12V DC Current 90mA Alluminio colour
---

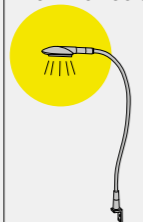

Code	P26.86F		

## Fabric (JENNY - KENYA) and faux leather (TAPE) covers

For COSY headboards  
To the ground

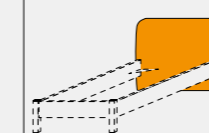

Suspended

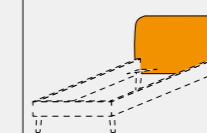

For beds W:	Code	Code	
90	PK50.93S	PK50.94Y	
120	PK51.00C	PK51.01K	

## Fabric (JENNY - KENYA) and faux leather (TAPE) covers

For beds

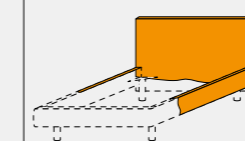

For beds with lifting base

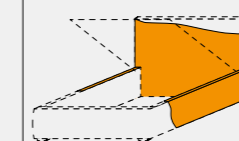

For beds W:	Code	Code	
90	NARCISO	PL56.07X	PL56.17C
	REVERSO	PK51.17D	PK51.18L
	VERSO	PK51.19S	PK51.20P
120	LINE	PK51.21V	PK51.22B
	NARCISO	PL56.15Q	PL56.24P
	REVERSO	PK51.23H	PK51.24Q
	SLIM	PL56.12V	PL56.21U
	SNUG	PL56.14H	PL56.23G
	VERSO	PK51.25W	PK51.26C

## ECOCHIC fabric and faux leather covers

For beds and beds with lifting base

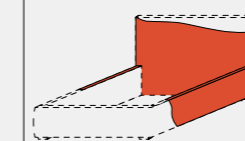

When ordering, specify for bed base Dpt 190 or 200

For beds W:	Code	Dpt 190	Dpt 200	
90	KANT	PL57.97A		
	PAD	PL57.95N		
	TETRIS	PL57.94F		
	TWIN	PL57.96U		
120	KANT	PL58.72M		
	PAD	PL57.99P		
	TETRIS	PL57.98G		
	TWIN	PL58.71E		

Components in <b>CARCASE</b> colors
Components in <b>GROUP 2</b> colors
Components in <b>Types and colors FRONT</b>
RW3Q RD5T CL1X B17A AL1A TR8A
B17A AL1A

BT4R OR1S RO3R RS8X VE5R MN4K BL6R AR3T
Bedes with contrasting seams. See the summary table at the top of the price list.
NOT for equipped beds with 2 <sup>nd</sup> base, big drawers and LIFT-UP base.

FABRIC JENNY	0402 0403 0503 0900 0903 0905 0314 0303 0805 0706 0704 0601 0604
FABRIC KENYA	0014 0013 0016 0020 0019
FAUX LEATHER TAPE	0111 0102 0603 0415 0503 0605 0700 0608 0901
FABRIC ECOCHIC	Z80B Z81G Z83P Z84S Z85V Z82L
FAUX LEATHER ECOCHIC	Z20B Z41G Z21R Z62R Z64X Z63U Z79Y



**GROUP 1 colors**

**GROUP 2 colors**

**GROUP 3 colors**

**CARCASE colors**

Rovere Dorian <b>RD5T</b>	Rovere white <b>RW3Q</b>	Noce naturale <b>NN7H</b>	Eucalipto <b>CL1X</b>	Domy <b>DM7P</b>	Bianco UV <b>BU3Q</b>
Ciliegio bianco <b>CB6K</b>	Malta <b>ML7H</b>	Feltro <b>FL8X</b>	Cemento Masdar <b>CM3Q</b>	Blu indaco <b>BI4B</b>	
Noce <b>NC4B</b>	Desert <b>DS9L</b>	Canapa <b>CN1X</b>	Moka <b>MK6B</b>	Cipria <b>CP4J</b>	
Bianco opaco <b>BI7A</b>	Grigio Dorian <b>GL4R</b>	Basalto <b>BS5T</b>	Grigio titanio <b>GZ8T</b>	Rosa bubble <b>RB7Y</b>	
	Agave <b>GV7A</b>	Verde Alpi <b>VA5T</b>	Cadaques <b>CQ3Q</b>	Giallo zafferano <b>GZ8A</b>	
	Blu opale <b>BO7H</b>			Corallo <b>CR5T</b>	

**Types and colors FRONT**

**ONE**

matte

glossy

**CLUB**

Specify the color of the CLUB handle

**WINDOW**

Specify the color of the aluminum frame

Rovere white <b>RW3Q</b>	Rovere Dorian <b>RD5T</b>	Ciliegio bianco <b>CB6K</b>	Noce naturale <b>NN7H</b>	Noce <b>NC4B</b>	Eucalipto <b>CL1X</b>	Malta <b>ML7H</b>
Feltro <b>FL8X</b>	Cemento Masdar <b>CM3Q</b>	Bianco opaco <b>BI7A</b>	Desert <b>DS9L</b>	Canapa <b>CN1X</b>	Moka <b>MK6B</b>	Grigio Dorian <b>GL4R</b>
Basalto <b>BS5T</b>	Grigio titanio <b>GZ8T</b>	Domy <b>DM7P</b>	Agave <b>GV7A</b>	Verde Alpi <b>VA5T</b>	Cadaques <b>CQ3Q</b>	Blu indaco <b>BI4B</b>
Blu opale <b>BO7H</b>	Cipria <b>CP4J</b>	Rosa bubble <b>RB7Y</b>	Giallo zafferano <b>GZ8A</b>	Corallo <b>CR5T</b>		

Bianco opaco <b>BI7A</b>	Desert <b>DS9L</b>	Canapa <b>CN1X</b>	Moka <b>MK6B</b>	Grigio Dorian <b>GL4R</b>	Basalto <b>BS5T</b>	Grigio titanio <b>GZ8T</b>
Domy <b>DM7P</b>	Agave <b>GV7A</b>	Verde Alpi <b>VA5T</b>	Cadaques <b>CQ3Q</b>	Blu indaco <b>BI4B</b>	Blu opale <b>BO7H</b>	Cipria <b>CP4J</b>
Rosa bubble <b>RB7Y</b>	Giallo zafferano <b>GZ8A</b>	Corallo <b>CR5T</b>				

Trasparente <b>TR9M</b>	Trasparente fumé <b>FT8P</b>	Stop-sol <b>ST6P</b>	Specchio <b>SP7L</b>
----------------------------	---------------------------------	-------------------------	-------------------------

Alluminio <b>AL1A</b>	Titan grey <b>TG7H</b>
--------------------------	---------------------------

**Desks - Shaped tops**

Desks - technical information	408
OPTIONAL for desks	409
Holes for built-in technology	410
Desks with POLDO shaped top Ht 77.6 - Dpt 60	412
Desks with SG100 shaped top Ht 77.6 - Dpt 65	416
Desks with SG101 shaped top Ht 77.6 - Dpt 65	421
Desks with SG102 shaped top Ht 77.6 - Dpt 65	426
Corner desks with SG500 shaped top Ht 77.6	430
Peninsulas with SG200 shaped top Ht 77.6 - Dpt 65	432
Peninsulas with SG201 shaped top Ht 77.6 - Dpt 65	433
Peninsulas with SG400, SG401 and SG402 shaped tops Ht 77.6	434
Shaped tops and bases H 75.1 for desks and peninsulas	436
LINEA writing desks with unfinished back panel Ht 77.6 - Dpt 57.1/45.8	438
ANCORA desks Ht 77.6 - Dpt 60	440
TWIG desks Ht 77.6 - Dpt 60	441
FLY desks Ht 77.6 - Dpt 57.1	442
LOFT desks Ht 75 - Dpt 59.7	443
ROUND desks Ht 72 - Dpt 45.6	443
PODIO desks Dpt 49	444
EVO desk Ht 90,5 - Dpt 50	445
BAIA desk Ht 99.3 - Dpt 54	445
Custom-made shaped tops WITHOUT HOLES for assembly	446
Designed shaped panels Th 2.5	448
Desk accessories	450



## Desks - technical information

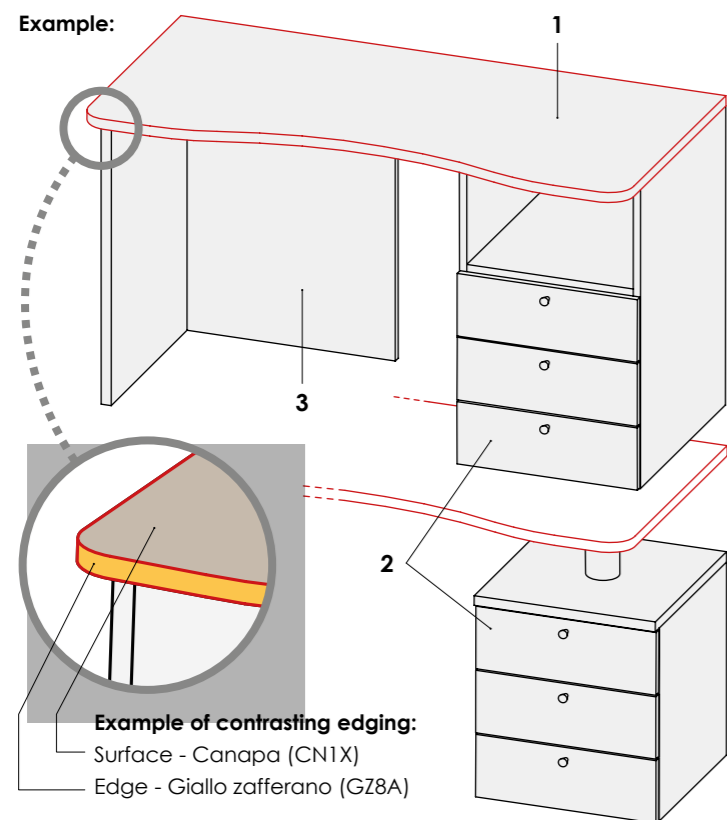

### 1 DESK TOPS

- Desk tops Th 1.8 and 2.5 cm are available in various standard sizes or custom sized (Th 2.5 only), with straight or shaped edges.
- Custom-made cuts are not available on shaped desk tops (except for custom-made items WITHOUT HOLES).
- Shaped components available with contrasting edging.
- **Built-in technology:**  
The desk tops can be fitted with optional built-in technology. The built-in technology consists of a cable pass-through channel, wireless charger<sup>1</sup> and two USB slots<sup>2</sup>, which can be added individually or combined. The holes on the desk top will be positioned by us as indicated in the chapter "Holes for built-in technology".  
**The built-in technology will be available on PODIO, POLDO, SG100, SG101, SG102, SG500, SG200, SG201, LINEA Dpt 57.1 and 45.8, ANCORA, TWIG and FLY desks.**

- <sup>1</sup> Wireless charging:  
**Qi wireless charging standard**
- <sup>2</sup> Dual USB socket:  
**Output: 5V DC - 2,10A Max. (1 x 2,10A) (2 x 1,05A)**

### 2 WRITING-DESK BLOCKS AND DRAWER UNITS

- Custom-made cuts are not available on Writing-desk blocks, Drawer units and metal parts.
- The doors are fitted with decelerated hinges.
- The drawers and big drawer CLUB are always fitted with height-adjustable, soft-close, "Quadro", metal slides with interior CHARM finish.
- Shelf, top, bottom and back panels in carcass colours.

### 3 DESK SUPPORTS

- Supports must only be used as recommended in the price list.
- All supports are Ht 75.1.
- Custom-made cuts are not available on metal supports and panel supports.
- **SLIM legs are always fitted at right angles to each other. This type of assembly also gives the desk greater stability.**

Panel supports:

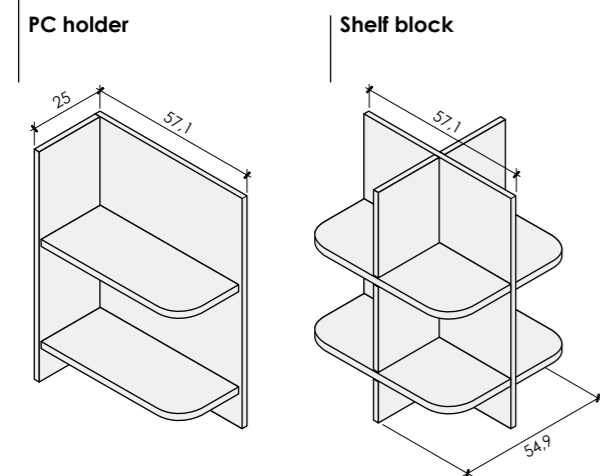

Metal supports:

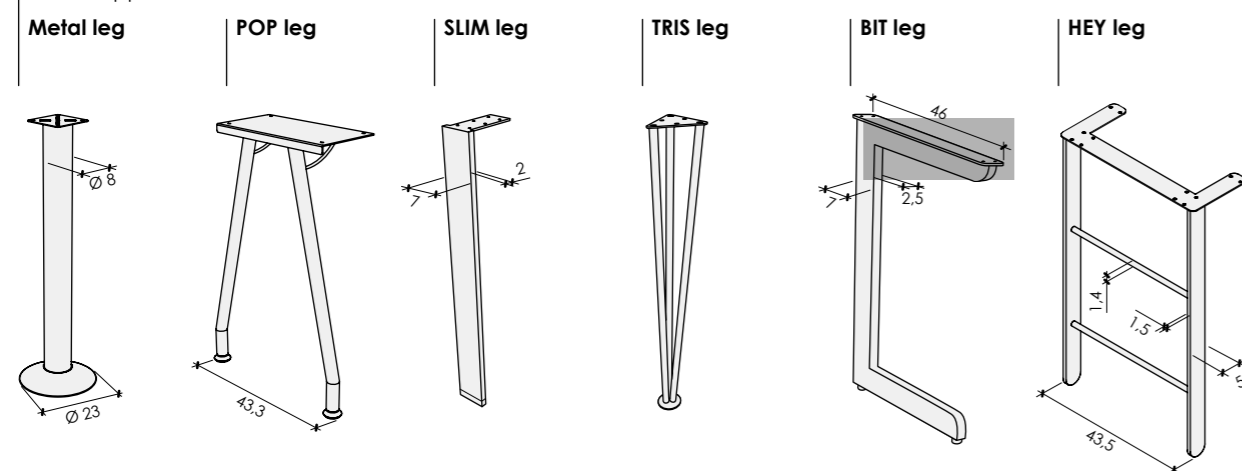

## OPTIONAL for desks

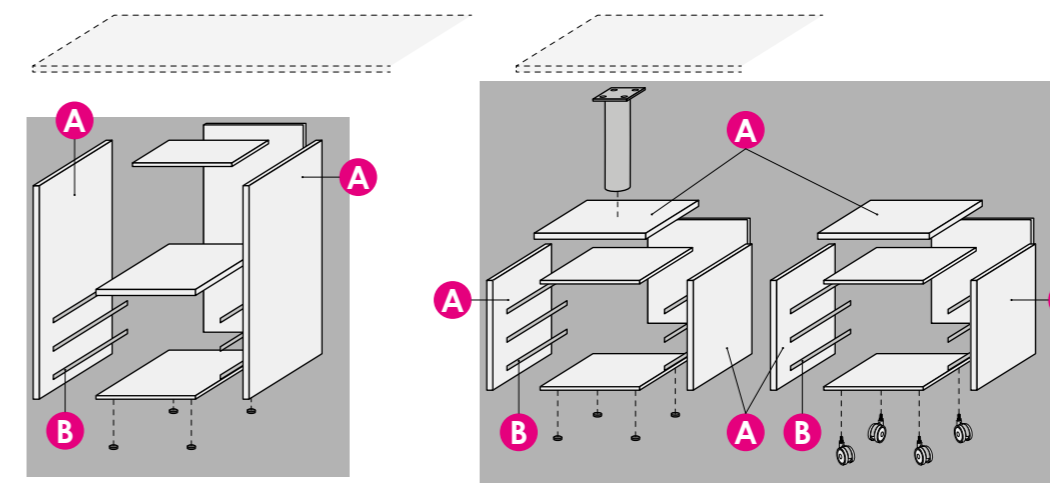

Writing-desk block

Drawer units

### A Extra colors for Side panels Writing-desk block and Drawer units

In addition to the standard CARCASE colors, the side panels are available in all the GROUP 2 colors with surcharge (see table).

- **When placing the order:** indicate the colour in the COLOURED FINISHES variant in Metron 4: all side panels will automatically be delivered in that colour.
- **N.B.** For the drawer units, the colour of the side panels will also determine the colour of the top.

### B Drawers and big drawers with soft-close

On request drawers and big drawers in the "standard" version can be equipped with soft-close mechanisms, with surcharge (see table). Alternatively, drawers and big drawers can be ordered in the CHARM version, with surcharge (see table), equipped with height-adjustable "Quadro" type runners with prestigious internal finish.

- **When placing the order:** indicate the type of runners in the RUNNER TYPE variant in Metron 4.
- **N.B.** the CLUB drawers and big drawers with soft-close "Quadro" type runners are supplied standard in the CHARM version (without surcharge).

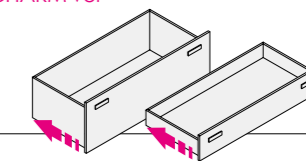

Side panels	Surcharge (CARCASE colors excluded)
Writing-desk block	
Drawer units	

Slow closing	Surcharge for single element
Drawers W 45 - 60 - 90	
Big drawers W 45 - 60 - 90	
CHARM Drawers/Big drawers with "Quadro" slides W 45 - 60 - 90	

### C Extra colors for Metal leg disc

The metal Leg is available in the colors Bianco opaco (BI7A) or Alluminio (AL1A); the disc at the base can be in a colour selected from among those available (see indications) with surcharge.

- **When placing the order:** indicate the colour of the disc in the FINISHES variant in Metron 4.
- **N.B.** The disc in the colour Alluminio (AL1A) does not have a surcharge.

BI7A GZ8T GV7A CQ3Q BI4B BO7H CP4J RB7Y CR5T AL1A

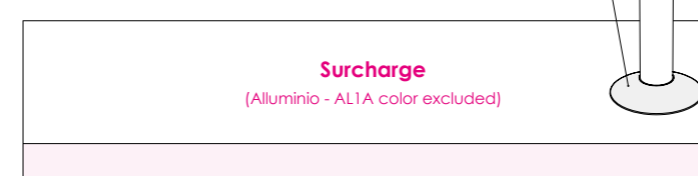

# Holes for built-in technology drilled by us on customer request

## Built-in technology:

When ordering a desk, it can be fitted with built-in accessories requiring holes to be drilled in the tops. One or more accessories can be chosen.

The elements on which these accessories can be fitted and the method for making the holes are described in these pages. Any exceptions are outlined in the technical specifications for each model.

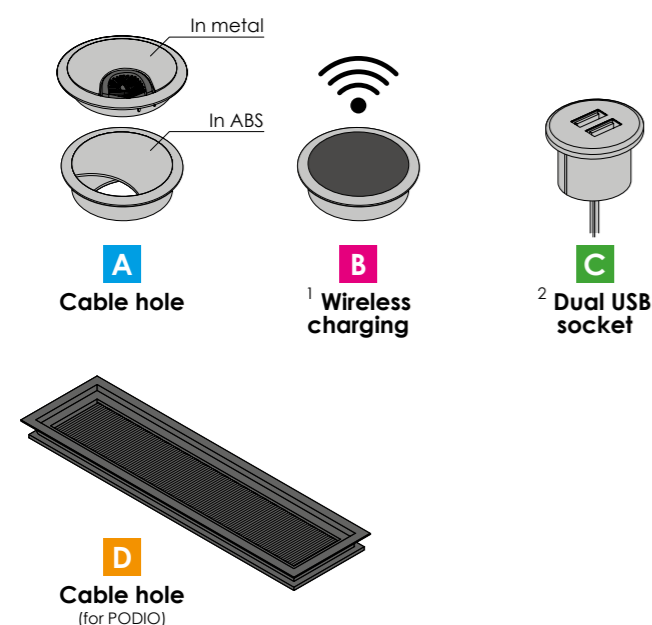

<sup>1</sup> Wireless charging:  
**Qi wireless charging standard**

<sup>2</sup> Dual USB socket:  
**Output: 5V DC - 2,10A Max. (1 x 2,10A) (2 x 1,05A)**

## DESK: PODIO

You can specify R or L on the PODIO W 120.  
Specify if you want the slot for the "D" cable pass-through on the right or left for PODIO W 150.

**N.B. The position of the holes is valid when ordering 1 or 2 accessories.**

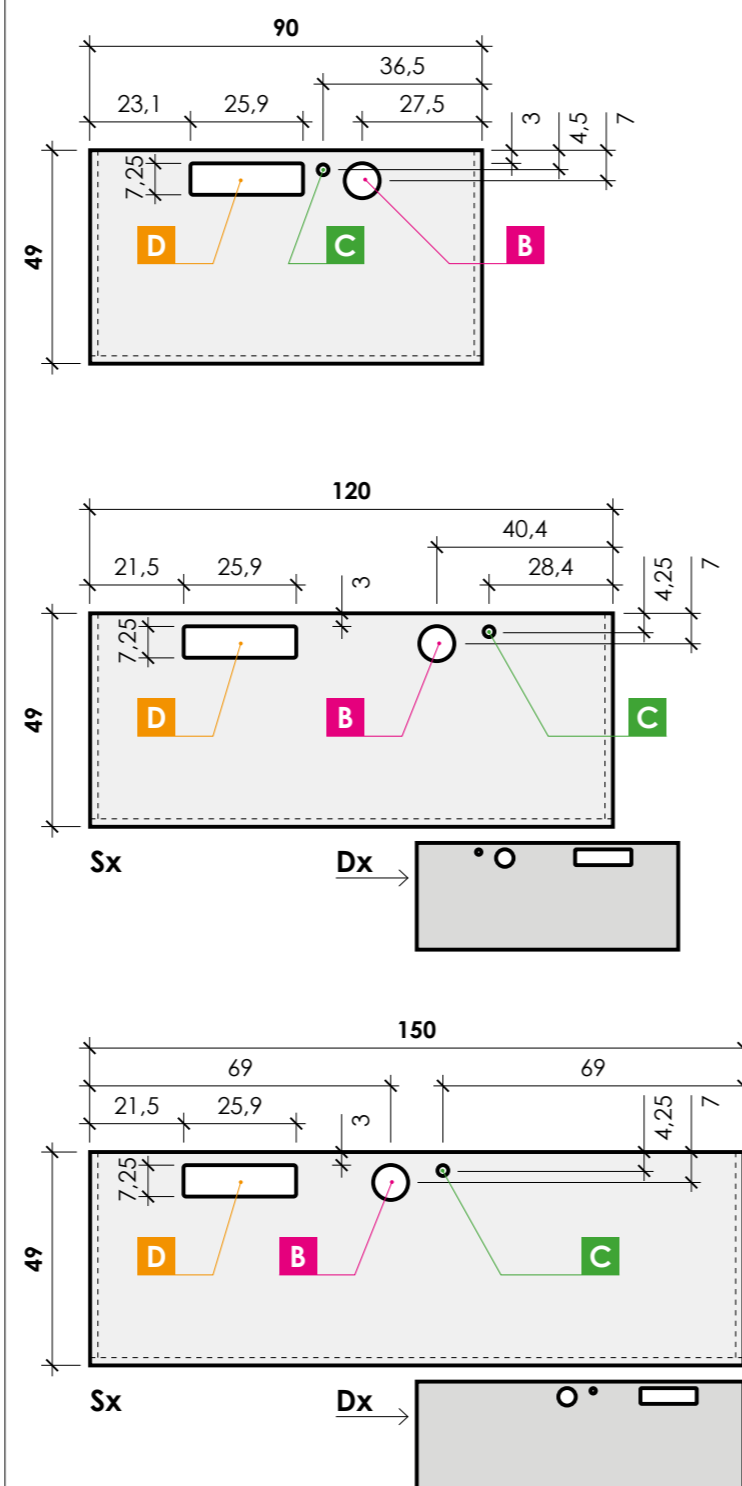

## DESKS with top Th 2.5: POLDO, SG100, SG101, SG102, SG500, SG200, SG201, LINEA, ANCORA, TWIG and FLY

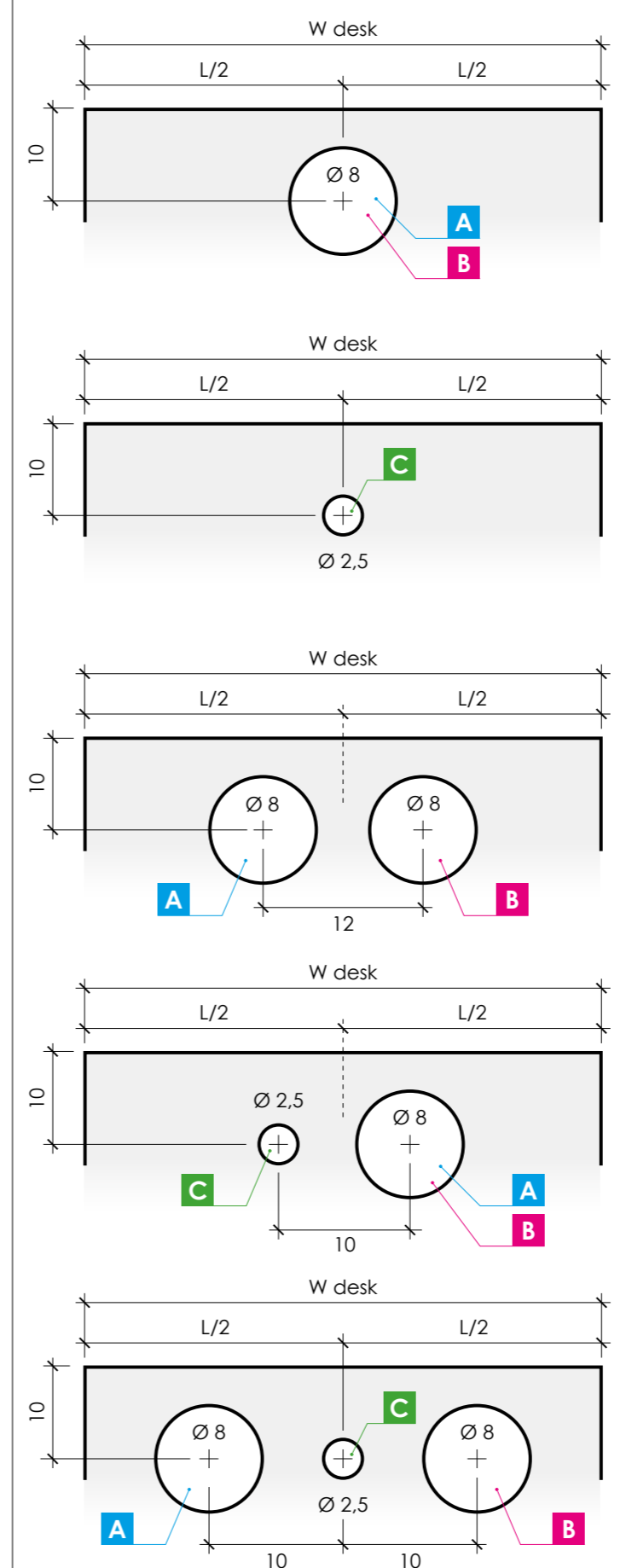



# Desks with POLDO shaped top Ht 77.6 - Dpt 60

## POLDO top Th 2.5

The top is shaped with ABS edging. Tops CANNOT be cut to customised.

On request, the top can be fitted with the following built-in technology:

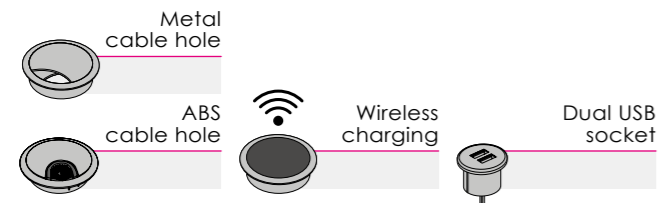

The holes required will be drilled in fixed positions. For details, see the chapter "Holes for built-in technology".

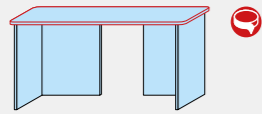
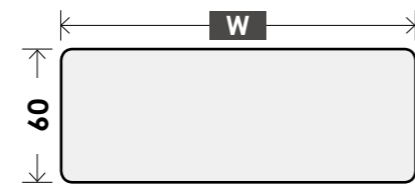

	W 135	W 150		
Code	PL53.00P	PL53.01V		

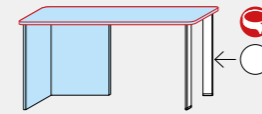

	W 135	W 150		
Code	PL53.15B	PL53.16H		

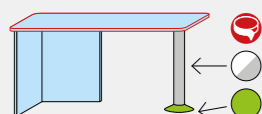

	W 135			
Code				

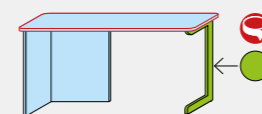

	W 135	W 150		
Code	PL53.05W	PL53.06C		

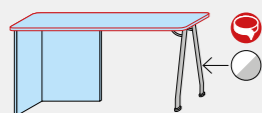

	W 135	W 150		
Code	PL53.11A	PL53.12G		

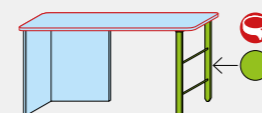

	W 135	W 150		
Code	PK44.00N	PK44.01U		

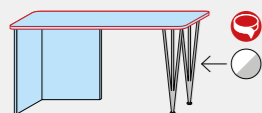

	W 135	W 150		
Code	PL53.02B	PL53.03H		

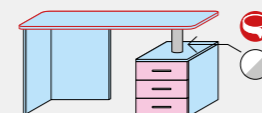

	W 135	W 150		
Code	PK44.02A	PK44.03G		
ONE	matte			
	glossy			
CLUB				

Components in GROUP 2 colors  
Components in Types and colors FRONT

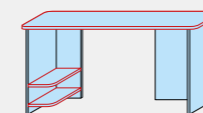

	W 135	W 150		
Code	PL53.13P	PL53.14V		

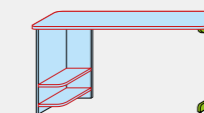

	W 135	W 150		
Code	PL53.33Z	PL53.34F		

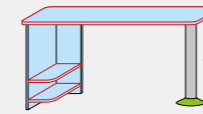

	W 135			
Code	PL53.17Q			

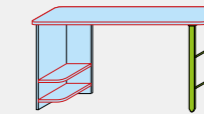

	W 135	W 150		
Code	PK44.04P	PK44.05V		

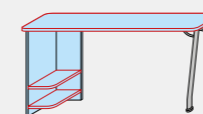

	W 135	W 150		
Code	PL53.22N	PL53.23U		

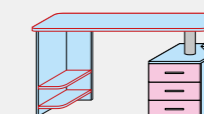

	W 150			
Code	PK44.06B			
ONE	matte			
	glossy			
CLUB				

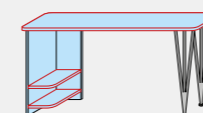

	W 135	W 150		
Code	PL53.29H	PL53.30E		

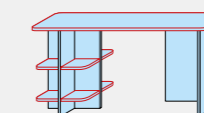

	W 135	W 150		
Code	PL53.57M	PL53.58T		

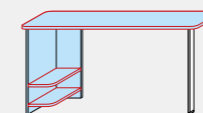

	W 135	W 150		
Code	PL53.25G	PL53.26P		

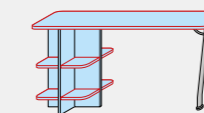

	W 135	W 150		
Code	PL53.63R	PL53.64X		



OPTIONAL: p. 409  
A · Extra colors for Side panels Writing-desk block and Drawer units  
B · Drawers and big drawers with soft-close  
C · Extra colors for Metal leg disc

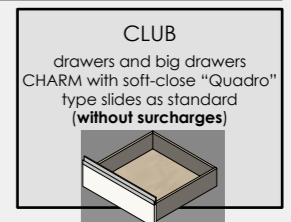

p. 56 Knob and handle positions  
p. 410 Holes for built-in technology  
p. 450 Desk accessories

# Desks with POLDO shaped top Ht 77.6 - Dpt 60

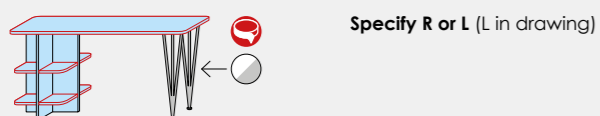

	W 135	W 150		
<b>Code</b>	<b>PL53.71H</b>	<b>PL53.72Q</b>		
ONE	matte			
	glossy			
CLUB				



	W 135	W 150		
<b>Code</b>	<b>PK44.11Z</b>	<b>PK44.12F</b>		
ONE	matte			
	glossy			
CLUB				



	W 135	W 150		
<b>Code</b>	<b>PK44.21E</b>	<b>PK44.22M</b>		
ONE	matte			
	glossy			
CLUB				



	W 135	W 150		
<b>Code</b>	<b>PK44.31L</b>	<b>PK44.32S</b>		
ONE	matte			
	glossy			
CLUB				

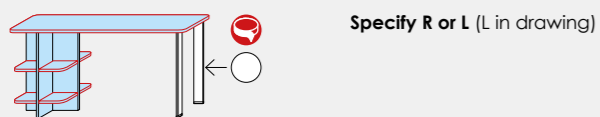

	W 135	W 150		
<b>Code</b>	<b>PL53.67S</b>	<b>PL53.68Y</b>		
ONE	matte			
	glossy			
CLUB				



	W 135	W 150		
<b>Code</b>	<b>PK44.13N</b>	<b>PK44.14U</b>		
ONE	matte			
	glossy			
CLUB				



	W 135	W 150		
<b>Code</b>	<b>PK44.23T</b>	<b>PK44.24Z</b>		
ONE	matte			
	glossy			
CLUB				



	W 135	W 150		
<b>Code</b>	<b>PL54.01Z</b>	<b>PL54.02F</b>		
ONE	matte			
	glossy			
CLUB				



	W 135	W 150		
<b>Code</b>	<b>PL53.75K</b>	<b>PL53.76R</b>		
ONE	matte			
	glossy			
CLUB				



	W 135	W 150		
<b>Code</b>	<b>PK44.15A</b>	<b>PK44.16G</b>		
ONE	matte			
	glossy			
CLUB				



	W 135	W 150		
<b>Code</b>	<b>PK44.25F</b>	<b>PK44.26N</b>		
ONE	matte			
	glossy			
CLUB				



	W 135	W 150		
<b>Code</b>	<b>PL53.93G</b>	<b>PL53.94P</b>		
ONE	matte			
	glossy			
CLUB				



	W 135	W 150		
<b>Code</b>	<b>PK44.07H</b>	<b>PK44.08Q</b>		
ONE	matte			
	glossy			
CLUB				



	W 135	W 150		
<b>Code</b>	<b>PK44.17P</b>	<b>PK44.18V</b>		
ONE	matte			
	glossy			
CLUB				



	W 135	W 150		
<b>Code</b>	<b>PK44.27U</b>	<b>PK44.28A</b>		
ONE	matte			
	glossy			
CLUB				



	W 135	W 150		
<b>Code</b>	<b>PL53.89R</b>	<b>PL53.90N</b>		
ONE	matte			
	glossy			
CLUB				

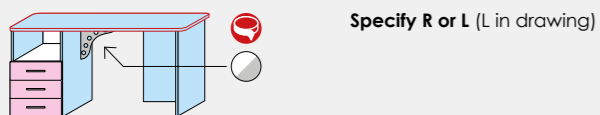

	W 135	W 150		
<b>Code</b>	<b>PK44.09W</b>	<b>PK44.10T</b>		
ONE	matte			
	glossy			
CLUB				



	W 135	W 150		
<b>Code</b>	<b>PK44.19B</b>	<b>PK44.20Y</b>		
ONE	matte			
	glossy			
CLUB				



	W 135	W 150		
<b>Code</b>	<b>PK44.29G</b>	<b>PK44.30D</b>		
ONE	matte			
	glossy			
CLUB				



	W 135	W 150		
<b>Code</b>	<b>PK47.05H</b>	<b>PK47.06Q</b>		
ONE	matte			
	glossy			
CLUB				

Components in **CARCASE** colors  
 Components in **GROUP 2** colors  
 Components in **Types and colors FRONT**

Shaped components available with contrasting edging.  
 B17A  GZ8T  GV7A  CQ3Q  B14B  B07H  CP4J  R87Y  CR5T  AL1A  
 B17A  AL1A  
 B17A

**OPTIONAL:** p. 409  
**A** · Extra colors for Side panels Writing-desk block and Drawer units  
**B** · Drawers and big drawers with soft-close  
**C** · Extra colors for Metal leg disc

**CLUB**  
 drawers and big drawers  
 CHARM with soft-close "Quadro"  
 type slides as standard  
 (without surcharges)

**p. 56** Knob and handle positions  
**p. 410** Holes for built-in technology  
**p. 450** Desk accessories



# Desks with SG100 shaped top Ht 77.6 - Dpt 65

## SG100 top Th 2.5

The top is shaped with ABS edging. Tops CANNOT be cut to customised. Desks W 165 and W 180 are complete with anti-bending bar. Specify R or L (L in drawing).

On request, the top can be fitted with the following built-in technology:

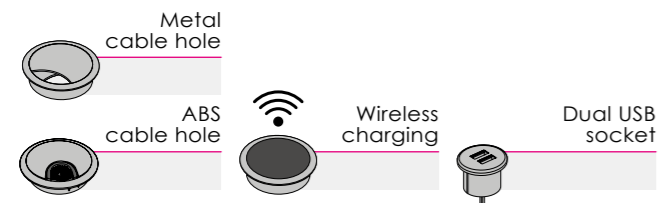

The holes required will be drilled in fixed positions. For details, see the chapter "Holes for built-in technology".

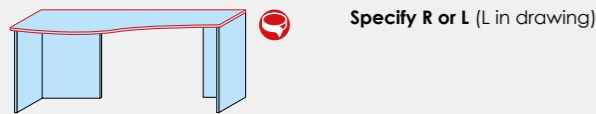
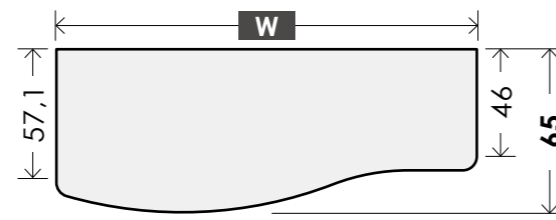

Specify R or L (L in drawing)

	W 135	W 150	W 165	W 180
Code	P38.61D	P38.62K	P38.63Q	P39.21Q
ONE				
CLUB				

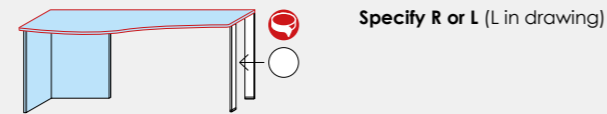

Specify R or L (L in drawing)

	W 135	W 150	W 165	W 180
Code	P03.01E	P03.02L	P03.03R	P03.04W
ONE				
CLUB				



Specify R or L (L in drawing)

	W 135	W 150	W 165	W 180
Code	P39.22V			
ONE				
CLUB				



Specify R or L (L in drawing)

	W 135	W 150	W 165	W 180
Code	PL54.03N	PL54.04U	PL54.05A	PL54.06G
ONE				
CLUB				



Specify R or L (L in drawing)

	W 135	W 150	W 165	W 180
Code	PL54.07P	PL54.08V	PL54.09B	PL54.10Y
ONE				
CLUB				



Specify R or L (L in drawing)

	W 135	W 150	W 165	W 180
Code	PK44.33Y	PK44.34E	PK44.35M	PK44.36T
ONE				
CLUB				



Specify R or L (L in drawing)

	W 135	W 150	W 165	W 180
Code	PL45.01A	PL45.02G	PL45.03P	PL45.04V
ONE				
CLUB				

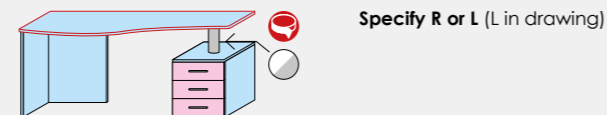

Specify R or L (L in drawing)

	W 135	W 150	W 165	W 180
Code	PK44.37Z	PK44.38F	PK44.39N	PK44.40K
ONE	matte			
	glossy			
CLUB				

Components in GROUP 2 colors  
Components in Types and colors FRONT



Specify R or L (L in drawing)

	W 135	W 150	W 165	W 180
Code	P76.16Q			
ONE				
CLUB				

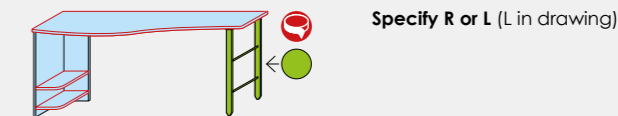

Specify R or L (L in drawing)

	W 135	W 150	W 165	W 180
Code	PK44.41R	PK44.42X	PK44.43D	PK44.44L
ONE				
CLUB				

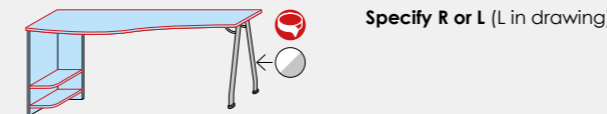

Specify R or L (L in drawing)

	W 135	W 150	W 165	W 180
Code	PL54.11E	PL54.12M	PL54.13T	PL54.14Z
ONE				
CLUB				

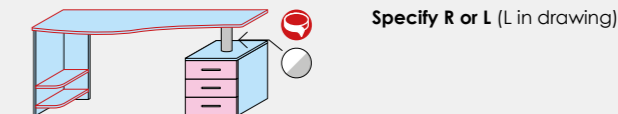

Specify R or L (L in drawing)

	W 150	W 165	W 180
Code	PK44.45S	PK44.46Y	PK44.47E
ONE	matte		
	glossy		
CLUB			



Specify R or L (L in drawing)

	W 135	W 150	W 165	W 180
Code	PL45.09C	PL45.10Z	PL45.11F	PL45.12N
ONE				
CLUB				



Specify R or L (L in drawing)

	W 135	W 150	W 165	W 180
Code	PL45.67X	PL45.68D	PL45.69L	PL45.70G
ONE				
CLUB				

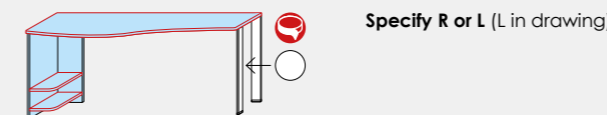

Specify R or L (L in drawing)

	W 135	W 150	W 165	W 180
Code	P03.05B	P03.06G	P03.07N	P03.08T
ONE				
CLUB				



Specify R or L (L in drawing)

	W 165	W 180
Code	PL45.71P	PL45.72V
ONE		
CLUB		



Specify R or L (L in drawing)

	W 135	W 150	W 165	W 180
Code	PL54.19G	PL54.20D	PL54.21L	PL54.22S
ONE				
CLUB				



Specify R or L (L in drawing)

	W 135	W 150	W 165	W 180
Code	PL54.35S	PL54.36Y	PL54.37E	PL54.38M
ONE				
CLUB				

OPTIONAL: p. 409  
A - Extra colors for Side panels Writing-desk block and Drawer units  
B - Drawers and big drawers with soft-close  
C - Extra colors for Metal leg disc

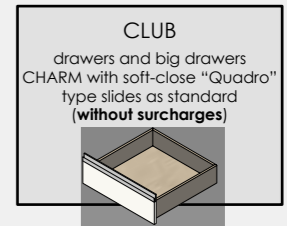

p. 56 Knob and handle positions  
p. 410 Holes for built-in technology  
p. 450 Desk accessories





# Desks with SG100 shaped top Ht 77.6 - Dpt 65

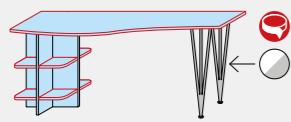

Specify R or L (L in drawing)

	W 135	W 150	W 165	W 180
Code	PL45.81U	PL45.82A	PL45.83G	PL45.84P
ONE	matte			
	glossy			
CLUB				

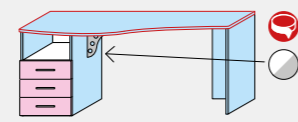

Specify R or L (L in drawing)

	W 135	W 150	W 165	W 180
Code	PK44.54R	PK44.55X	PK44.56D	PK44.57L
ONE	matte			
	glossy			
CLUB				

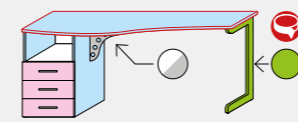

Specify R or L (L in drawing)

	W 135	W 150	W 165	W 180
Code	PK44.74B	PK44.75H	PK44.76Q	PK44.77W
ONE	matte			
	glossy			
CLUB				

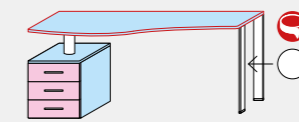

Specify R or L (L in drawing)

	W 135	W 150	W 165	W 180
Code	PK44.94N	PK44.95U	PK44.96A	PK44.97G
ONE	matte			
	glossy			
CLUB				

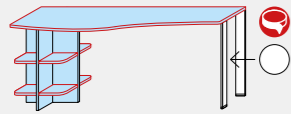

Specify R or L (L in drawing)

	W 135	W 150	W 165	W 180
Code	PL45.77C	PL45.78K	PL45.79R	PL45.80N
ONE	matte			
	glossy			
CLUB				

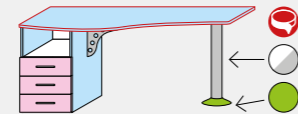

Specify R or L (L in drawing)

	W 135	W 150	W 165	W 180
Code	PK44.58S	PK44.59Y	PK44.60V	PK44.61B
ONE	matte			
	glossy			
CLUB				

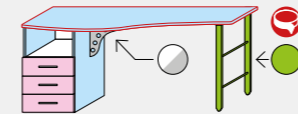

Specify R or L (L in drawing)

	W 135	W 150	W 165	W 180
Code	PK44.78C	PK44.79K	PK44.80F	PK44.81N
ONE	matte			
	glossy			
CLUB				

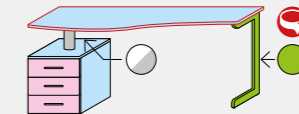

Specify R or L (L in drawing)

	W 135	W 150	W 165	W 180
Code	PK44.98P	PK44.99V	PK45.00S	PK45.01Y
ONE	matte			
	glossy			
CLUB				



Specify R or L (L in drawing)

	W 135	W 150	W 165	W 180
Code	PL54.43K	PL54.44R	PL54.45X	PL54.46D
ONE	matte			
	glossy			
CLUB				

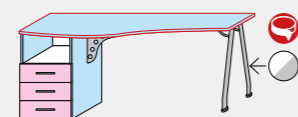

Specify R or L (L in drawing)

	W 135	W 150	W 165	W 180
Code	PK44.62H	PK44.63Q	PK44.64W	PK44.65C
ONE	matte			
	glossy			
CLUB				

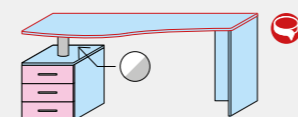

Specify R or L (L in drawing)

	W 135	W 150	W 165	W 180
Code	PK44.82U	PK44.83A	PK44.84G	PK44.85P
ONE	matte			
	glossy			
CLUB				

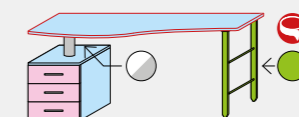

Specify R or L (L in drawing)

	W 135	W 150	W 165	W 180
Code	PK45.02E	PK45.03M	PK45.04T	PK45.05Z
ONE	matte			
	glossy			
CLUB				

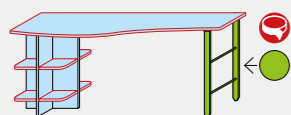

Specify R or L (L in drawing)

	W 135	W 150	W 165	W 180
Code	PK44.48M	PK44.49T	PK44.50Q	PK44.51W
ONE	matte			
	glossy			
CLUB				

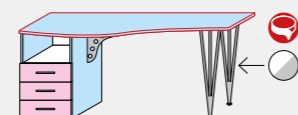

Specify R or L (L in drawing)

	W 135	W 150	W 165	W 180
Code	PK44.66K	PK44.67R	PK44.68X	PK44.69D
ONE	matte			
	glossy			
CLUB				

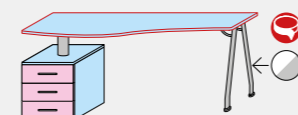

Specify R or L (L in drawing)

	W 135	W 150	W 165	W 180
Code	PK44.86V	PK44.87B	PK44.88H	PK44.89Q
ONE	matte			
	glossy			
CLUB				

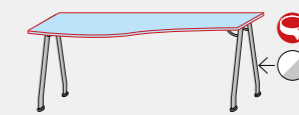

Specify R or L (L in drawing)

	W 135	W 150	W 165	W 180
Code	PL54.51B	PL54.52H	PL54.53Q	PL54.54W
ONE	matte			
	glossy			
CLUB				



Specify R or L (L in drawing)

	W 165	W 180
Code	PK44.52C	PK44.53K
ONE	matte	
	glossy	
CLUB		

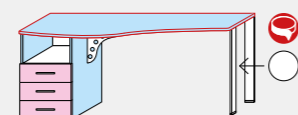

Specify R or L (L in drawing)

	W 135	W 150	W 165	W 180
Code	PK44.70A	PK44.71G	PK44.72P	PK44.73V
ONE	matte			
	glossy			
CLUB				

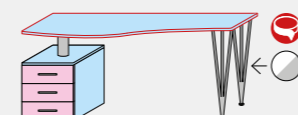

Specify R or L (L in drawing)

	W 135	W 150	W 165	W 180
Code	PK44.90M	PK44.91T	PK44.92Z	PK44.93F
ONE	matte			
	glossy			
CLUB				

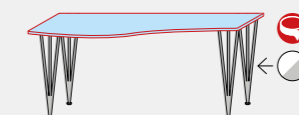

Specify R or L (L in drawing)

	W 135	W 150	W 165	W 180
Code	PL46.07U	PL46.08A	PL46.09G	PL46.10D
ONE	matte			
	glossy			
CLUB				

- Components in **CARCASE** colors
- Components in **GROUP 2** colors
- Components in **Types and colors FRONT**

Shaped components available with contrasting edging.

**OPTIONAL:** p. 409  
 A · Extra colors for Side panels Writing-desk block and Drawer units  
 B · Drawers and big drawers with soft-close  
 C · Extra colors for Metal leg disc

**CLUB**  
 drawers and big drawers  
 CHARM with soft-close "Quadro"  
 type slides as standard  
 (without surcharges)

p. 56 Knob and handle positions  
 p. 410 Holes for built-in technology  
 p. 450 Desk accessories



# Desks with SG100 shaped top Ht 77.6 - Dpt 65



Specify R or L (L in drawing)

	W 135	W 150	W 165	W 180
Code	P03.17S	P03.18X	P03.19C	P03.20H

# Desks with SG101 shaped top Ht 77.6 - Dpt 65



## SG101 top Th 2.5

The top is shaped with ABS edging. Tops CANNOT be cut to customised. Desks W 165 and W 180 are complete with anti-bending bar. On request, the top can be fitted with the following built-in technology:

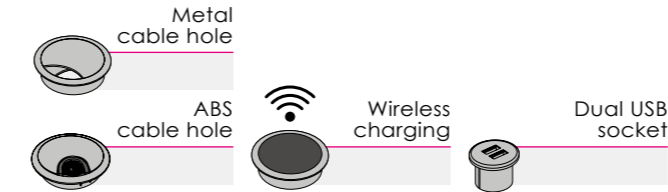

The holes required will be drilled in fixed positions. For details, see the chapter "Holes for built-in technology".

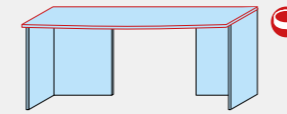
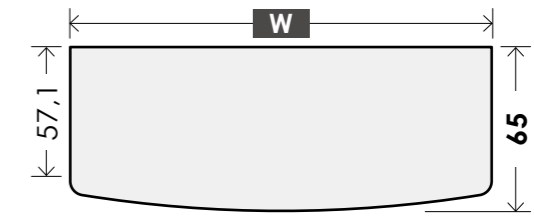

	W 135	W 150	W 165	W 180
Code	P56.97X	P56.98C	P56.99H	P57.00Y

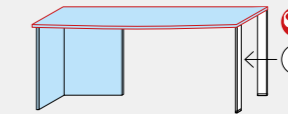

	W 135	W 150	W 165	W 180
Code	P03.21P	P03.22U	P03.23Z	P03.24E

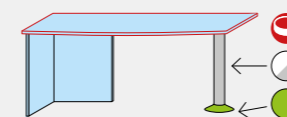

	W 135	W 150	W 165	W 180
Code	P57.30M			

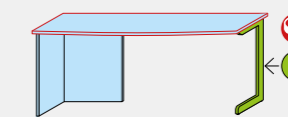

	W 135	W 150	W 165	W 180
Code	PL54.63V	PL54.64B	PL54.65H	PL54.66Q

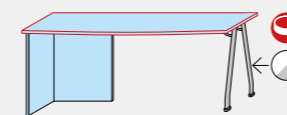

	W 135	W 150	W 165	W 180
Code	PL54.67W	PL54.68C	PL54.69K	PL54.70F

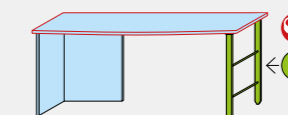

	W 135	W 150	W 165	W 180
Code	PK45.06F	PK45.07N	PK45.08U	PK45.09A

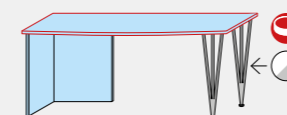

	W 135	W 150	W 165	W 180
Code	PL46.11L	PL46.12S	PL46.13Y	PL46.14E

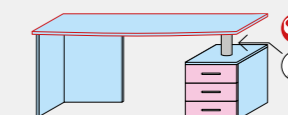

	W 135	W 150	W 165	W 180
Code	PK45.10X	PK45.11D	PK45.12L	PK45.13S
ONE	matte			
	glossy			
CLUB				

Components in GROUP 2 colors  
Components in Types and colors FRONT



**OPTIONAL:** p. 409  
A · Extra colors for Side panels Writing-desk block and Drawer units  
B · Drawers and big drawers with soft-close  
C · Extra colors for Metal leg disc

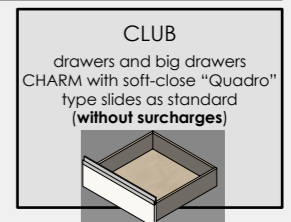

p. 56 Knob and handle positions  
p. 410 Holes for built-in technology  
p. 450 Desk accessories



# Desks with SG101 shaped top Ht 77.6 - Dpt 65

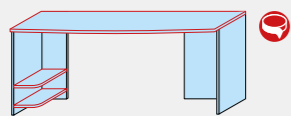

Specify R or L (L in drawing)

	W 135	W 150	W 165	W 180
Code	P76.24E	P76.25L	P76.26R	P76.27W
ONE				
CLUB				

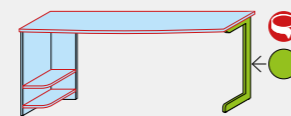

Specify R or L (L in drawing)

	W 135	W 150	W 165	W 180
Code	PL54.79Q	PL54.80M	PL54.81T	PL54.82Z
ONE				
CLUB				

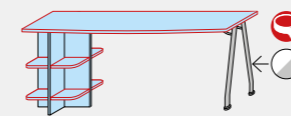

Specify R or L (L in drawing)

	W 135	W 150	W 165	W 180
Code	PL54.95Z	PL54.96F	PL54.97N	PL54.98U
ONE				
CLUB				

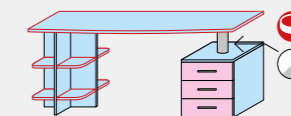

Specify R or L (L in drawing)

		W 165	W 180
Code		PK45.25L	PK45.26S
ONE	matte		
	glossy		
CLUB			

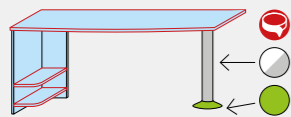

Specify R or L (L in drawing)

	W 135			
Code	P76.28B			
ONE				
CLUB				

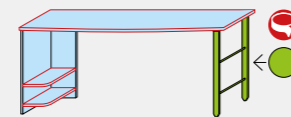

Specify R or L (L in drawing)

	W 135	W 150	W 165	W 180
Code	PK45.14Y	PK45.15E	PK45.16M	PK45.17T
ONE				
CLUB				

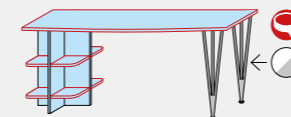

Specify R or L (L in drawing)

	W 135	W 150	W 165	W 180
Code	PL46.91D	PL46.92L	PL46.93S	PL46.94Y
ONE				
CLUB				

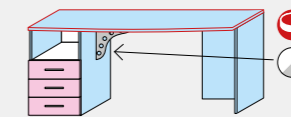

Specify R or L (L in drawing)

	W 135	W 150	W 165	W 180
Code	PK45.27Y	PK45.28E	PK45.29M	PK45.30H
ONE	matte			
	glossy			
CLUB				

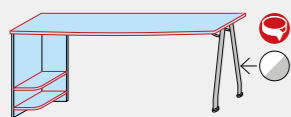

Specify R or L (L in drawing)

	W 135	W 150	W 165	W 180
Code	PL54.71N	PL54.72U	PL54.73A	PL54.74G
ONE				
CLUB				

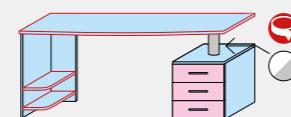

Specify R or L (L in drawing)

		W 150	W 165	W 180
Code		PK45.18Z	PK45.19F	PK45.20C
ONE	matte			
	glossy			
CLUB				

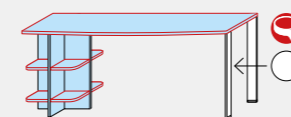

Specify R or L (L in drawing)

	W 135	W 150	W 165	W 180
Code	PL46.87N	PL46.88U	PL46.89A	PL46.90X
ONE				
CLUB				

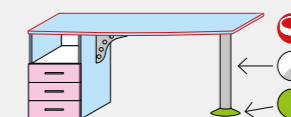

Specify R or L (L in drawing)

	W 135	W 150	W 165	W 180
Code	PK45.31Q	PK45.32W	PK45.33C	PK45.34K
ONE	matte			
	glossy			
CLUB				

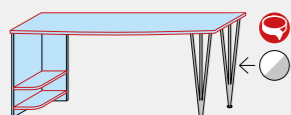

Specify R or L (L in drawing)

	W 135	W 150	W 165	W 180
Code	PL46.19N	PL46.20K	PL46.21R	PL46.22X
ONE				
CLUB				

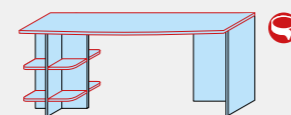

Specify R or L (L in drawing)

	W 135	W 150	W 165	W 180
Code	PL46.77G	PL46.78P	PL46.79V	PL46.80S
ONE				
CLUB				

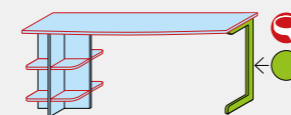

Specify R or L (L in drawing)

	W 135	W 150	W 165	W 180
Code	PL52.86S	PL52.87Y	PL52.88E	PL52.89M
ONE				
CLUB				

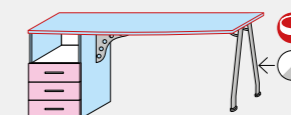

Specify R or L (L in drawing)

	W 135	W 150	W 165	W 180
Code	PK45.35R	PK45.36X	PK45.37D	PK45.38L
ONE	matte			
	glossy			
CLUB				

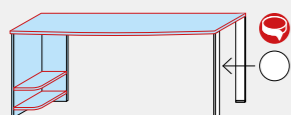

Specify R or L (L in drawing)

	W 135	W 150	W 165	W 180
Code	P03.25L	P03.26R	P03.27W	P03.28B
ONE				
CLUB				

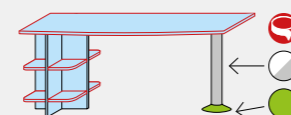

Specify R or L (L in drawing)

		W 165	W 180
Code		PL46.81Y	PL46.82E
ONE			
CLUB			

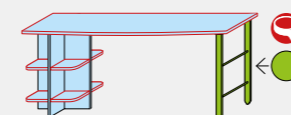

Specify R or L (L in drawing)

	W 135	W 150	W 165	W 180
Code	PK45.21K	PK45.22R	PK45.23X	PK45.24D
ONE				
CLUB				

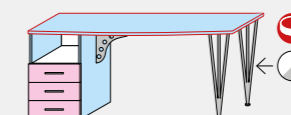

Specify R or L (L in drawing)

	W 135	W 150	W 165	W 180
Code	PK45.39S	PK45.40P	PK45.41V	PK45.42B
ONE	matte			
	glossy			
CLUB				

□ Components in **CARCASE** colors  
 □ Components in **GROUP 2** colors  
 □ Components in **Types and colors FRONT**

○ Shaped components available with contrasting edging.  
 ● B17A GZ8T GV7A CQ3Q B14B BO7H CP4J R87Y CR5T AL1A  
 ○ B17A AL1A  
 ○ B17A



**OPTIONAL:**  
 p. 409  
 A · Extra colors for Side panels Writing-desk block and Drawer units  
 B · Drawers and big drawers with soft-close  
 C · Extra colors for Metal leg disc

**CLUB**  
 drawers and big drawers  
 CHARM with soft-close "Quadro"  
 type slides as standard  
 (without surcharges)

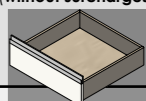

p. 56 Knob and handle positions  
 p. 410 Holes for built-in technology  
 p. 450 Desk accessories

# Desks with SG101 shaped top Ht 77.6 - Dpt 65



	W 135	W 150	W 165	W 180
<b>Code</b>	<b>PK45.43H</b>	<b>PK45.44Q</b>	<b>PK45.45W</b>	<b>PK45.46C</b>
ONE	matte			
	glossy			
CLUB				



	W 135	W 150	W 165	W 180
<b>Code</b>	<b>PK45.63U</b>	<b>PK45.64A</b>	<b>PK45.65G</b>	<b>PK45.66P</b>
ONE	matte			
	glossy			
CLUB				

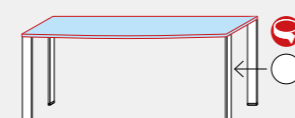

	W 135	W 150	W 165	W 180
<b>Code</b>	<b>P03.37A</b>	<b>P03.38F</b>	<b>P03.39M</b>	<b>P03.40S</b>
ONE				
CLUB				



	W 135	W 150	W 165	W 180
<b>Code</b>	<b>PK45.47K</b>	<b>PK45.48R</b>	<b>PK45.49X</b>	<b>PK45.50U</b>
ONE	matte			
	glossy			
CLUB				



	W 135	W 150	W 165	W 180
<b>Code</b>	<b>PK45.67V</b>	<b>PK45.68B</b>	<b>PK45.69H</b>	<b>PK45.70E</b>
ONE	matte			
	glossy			
CLUB				

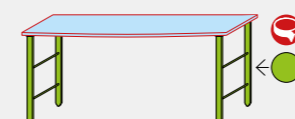

	W 135	W 150	W 165	W 180
<b>Code</b>	<b>PK47.07W</b>	<b>PK47.08C</b>	<b>PK47.09K</b>	<b>PK47.10F</b>
ONE				
CLUB				



	W 135	W 150	W 165	W 180
<b>Code</b>	<b>PK45.51A</b>	<b>PK45.52G</b>	<b>PK45.53P</b>	<b>PK45.54V</b>
ONE	matte			
	glossy			
CLUB				



	W 135	W 150	W 165	W 180
<b>Code</b>	<b>PK45.71M</b>	<b>PK45.72T</b>	<b>PK45.73Z</b>	<b>PK45.74F</b>
ONE	matte			
	glossy			
CLUB				



	W 135	W 150	W 165	W 180
<b>Code</b>	<b>PK45.55B</b>	<b>PK45.56H</b>	<b>PK45.57Q</b>	<b>PK45.58W</b>
ONE	matte			
	glossy			
CLUB				



	W 135	W 150	W 165	W 180
<b>Code</b>	<b>PL52.94K</b>	<b>PL52.95R</b>	<b>PL52.96X</b>	<b>PL52.97D</b>
ONE				
CLUB				



	W 135	W 150	W 165	W 180
<b>Code</b>	<b>PK45.59C</b>	<b>PK45.60Z</b>	<b>PK45.61F</b>	<b>PK45.62N</b>
ONE	matte			
	glossy			
CLUB				



	W 135	W 150	W 165	W 180
<b>Code</b>	<b>PL47.17D</b>	<b>PL47.18L</b>	<b>PL47.19S</b>	<b>PL47.20P</b>
ONE				
CLUB				

- Components in **CARCASE** colors
- Components in **GROUP 2** colors
- Components in **Types and colors FRONT**

- Shaped components available with contrasting edging.
- B17A
- GZ8T
- GV7A
- CQ3Q
- B14B
- B07H
- CP4J
- R87Y
- CR5T
- AL1A
- B17A
- AL1A
- B17A



**OPTIONAL:** **A** · Extra colors for Side panels Writing-desk block and Drawer units  
**p. 409** **B** · Drawers and big drawers with soft-close  
**C** · Extra colors for Metal leg disc

**CLUB**

drawers and big drawers  
CHARM with soft-close "Quadro"  
type slides as standard  
(without surcharges)



**p. 56** Knob and handle positions  
**p. 410** Holes for built-in technology  
**p. 450** Desk accessories



# Desks with SG102 shaped top Ht 77.6 - Dpt 65

## SG102 top Th 2.5

The top is shaped with ABS edging. Tops CANNOT be cut to customised. Desks W 165 and W 180 are complete with anti-bending bar. On request, the top can be fitted with the following built-in technology:

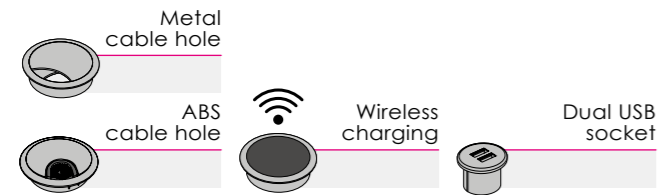

The holes required will be drilled in fixed positions. For details, see the chapter "Holes for built-in technology".

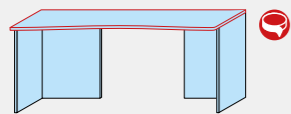
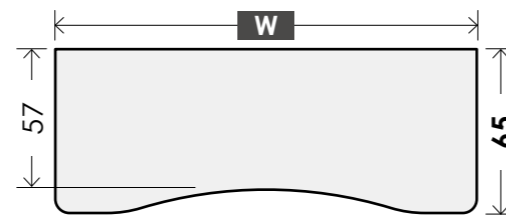

	W 135	W 150	W 165	W 180
Code	P58.62P	P58.68W	P58.72T	P58.74D

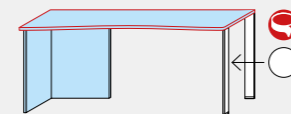

	W 135	W 150	W 165	W 180
Code	P03.41X	P03.42C	P03.43H	P03.44P

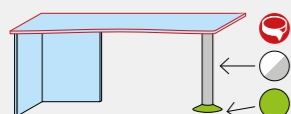

	W 135	W 150	W 165	W 180
Code	P58.78A			

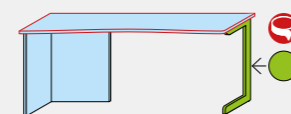

	W 135	W 150	W 165	W 180
Code	PL30.06H	PL30.07Q	PL30.08W	PL30.09C

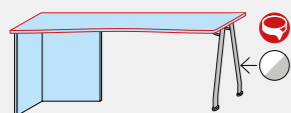

	W 135	W 150	W 165	W 180
Code	PL30.10Z	PL30.11F	PL30.12N	PL30.13U

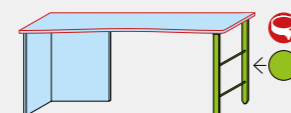

	W 135	W 150	W 165	W 180
Code	PK45.75N	PK45.76U	PK45.77A	PK45.78G

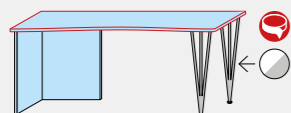

	W 135	W 150	W 165	W 180
Code	PL47.21V	PL47.22B	PL47.23H	PL47.24Q

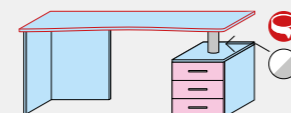

	W 135	W 150	W 165	W 180
Code	PK45.79P	PK45.80L	PK45.81S	PK45.82Y
ONE	matte			
	glossy			
CLUB				

Components in **GROUP 2** colors  
Components in **Types and colors FRONT**

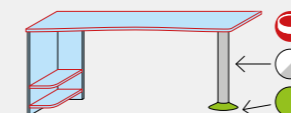

	W 135	W 150	W 165	W 180
Code	P76.39M			

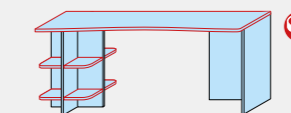

	W 135	W 150	W 165	W 180
Code	PL47.83R	PL47.84X	PL47.85D	PL47.86L

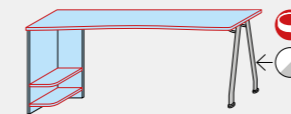

	W 135	W 150	W 165	W 180
Code	PL30.14A	PL30.15G	PL30.16P	PL30.17V

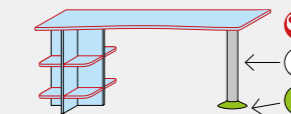

	W 135	W 150	W 165	W 180
Code			PL47.87S	PL47.88Y

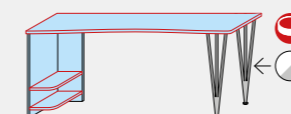

	W 135	W 150	W 165	W 180
Code	PL47.29X	PL47.30U	PL47.31A	PL47.32G

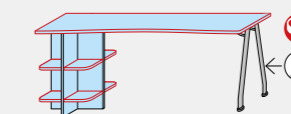

	W 135	W 150	W 165	W 180
Code	PL30.34M	PL30.35T	PL30.36Z	PL30.37F

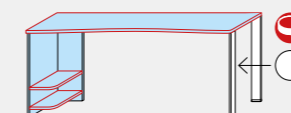

	W 135	W 150	W 165	W 180
Code	P03.45U	P03.46Z	P03.47E	P03.48L

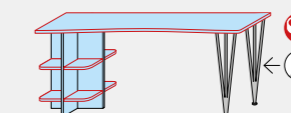

	W 135	W 150	W 165	W 180
Code	PL47.97X	PL47.98D	PL47.99L	PL48.00G

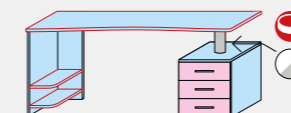

	W 150	W 165	W 180
Code	PK45.83E	PK45.84M	PK45.85T
ONE	matte		
	glossy		
CLUB			

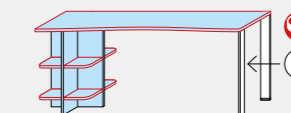

	W 135	W 150	W 165	W 180
Code	PL47.93W	PL47.94C	PL47.95K	PL47.96R



**OPTIONAL:** p. 409  
A · Extra colors for Side panels Writing-desk block and Drawer units  
B · Drawers and big drawers with soft-close  
C · Extra colors for Metal leg disc

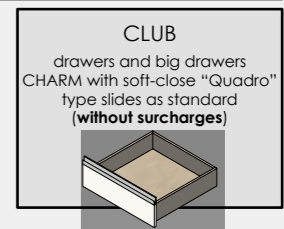

**CLUB**  
drawers and big drawers  
CHARM with soft-close "Quadro"  
type slides as standard  
(without surcharges)



p. 56 Knob and handle positions  
p. 410 Holes for built-in technology  
p. 450 Desk accessories

# Desks with SG102 shaped top Ht 77.6 - Dpt 65

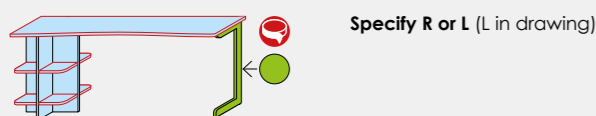

Specify R or L (L in drawing)

	W 135	W 150	W 165	W 180
<b>Code</b>	<b>PL30.42D</b>	<b>PL30.43L</b>	<b>PL30.44S</b>	<b>PL30.45Y</b>
ONE				
CLUB				



Specify R or L (L in drawing)

	W 135	W 150	W 165	W 180
<b>Code</b>	<b>PK46.00W</b>	<b>PK46.01C</b>	<b>PK46.02K</b>	<b>PK46.03R</b>
ONE	matte			
	glossy			
CLUB				



Specify R or L (L in drawing)

	W 135	W 150	W 165	W 180
<b>Code</b>	<b>PK46.21P</b>	<b>PK46.22V</b>	<b>PK46.23B</b>	<b>PK46.24H</b>
ONE	matte			
	glossy			
CLUB				

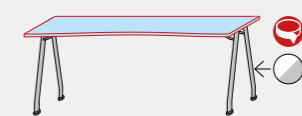

	W 135	W 150	W 165	W 180
<b>Code</b>	<b>PL30.58Y</b>	<b>PL30.59E</b>	<b>PL30.60B</b>	<b>PL30.61H</b>
ONE				
CLUB				



Specify R or L (L in drawing)

	W 135	W 150	W 165	W 180
<b>Code</b>	<b>PK45.86Z</b>	<b>PK45.87F</b>	<b>PK45.88N</b>	<b>PK45.89U</b>
ONE				
CLUB				



Specify R or L (L in drawing)

	W 135	W 150	W 165	W 180
<b>Code</b>	<b>PK46.04X</b>	<b>PK46.05D</b>	<b>PK46.07S</b>	<b>PK46.08Y</b>
ONE	matte			
	glossy			
CLUB				



Specify R or L (L in drawing)

	W 135	W 150	W 165	W 180
<b>Code</b>	<b>PK46.25Q</b>	<b>PK46.26W</b>	<b>PK46.27C</b>	<b>PK46.28K</b>
ONE	matte			
	glossy			
CLUB				

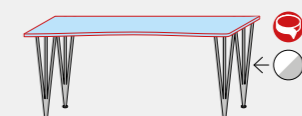

	W 135	W 150	W 165	W 180
<b>Code</b>	<b>PL48.23N</b>	<b>PL48.24U</b>	<b>PL48.25A</b>	<b>PL48.26G</b>
ONE				
CLUB				

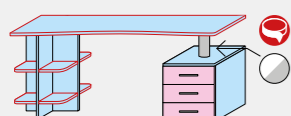

Specify R or L (L in drawing)

		W 165	W 180
<b>Code</b>		<b>PK45.90R</b>	<b>PK45.91X</b>
ONE	matte		
	glossy		
CLUB			

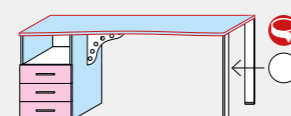

Specify R or L (L in drawing)

	W 135	W 150	W 165	W 180
<b>Code</b>	<b>PK46.09E</b>	<b>PK46.10B</b>	<b>PK46.11H</b>	<b>PK46.12Q</b>
ONE	matte			
	glossy			
CLUB				

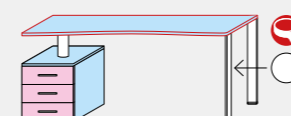

Specify R or L (L in drawing)

	W 135	W 150	W 165	W 180
<b>Code</b>	<b>PK46.29R</b>	<b>PK46.30N</b>	<b>PK46.31U</b>	<b>PK46.32A</b>
ONE	matte			
	glossy			
CLUB				

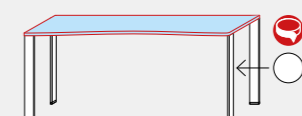

	W 135	W 150	W 165	W 180
<b>Code</b>	<b>P03.57K</b>	<b>P03.58Q</b>	<b>P03.59V</b>	<b>P03.60A</b>
ONE				
CLUB				

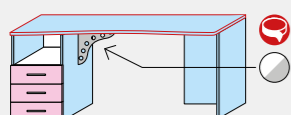

Specify R or L (L in drawing)

	W 135	W 150	W 165	W 180
<b>Code</b>	<b>PK45.92D</b>	<b>PK45.93L</b>	<b>PK45.94S</b>	<b>PK45.95Y</b>
ONE	matte			
	glossy			
CLUB				

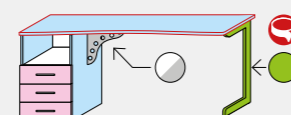

Specify R or L (L in drawing)

	W 135	W 150	W 165	W 180
<b>Code</b>	<b>PK46.13W</b>	<b>PK46.14C</b>	<b>PK46.15K</b>	<b>PK46.16R</b>
ONE	matte			
	glossy			
CLUB				

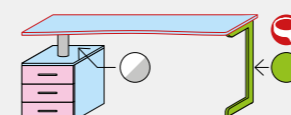

Specify R or L (L in drawing)

	W 135	W 150	W 165	W 180
<b>Code</b>	<b>PK46.33G</b>	<b>PK46.34P</b>	<b>PK46.35V</b>	<b>PK46.36B</b>
ONE	matte			
	glossy			
CLUB				

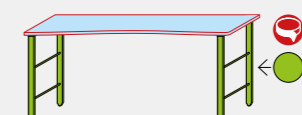

	W 135	W 150	W 165	W 180
<b>Code</b>	<b>PK47.11N</b>	<b>PK47.12U</b>	<b>PK47.13A</b>	<b>PK47.14G</b>
ONE				
CLUB				

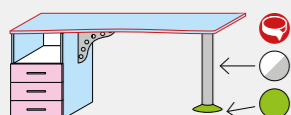

Specify R or L (L in drawing)

	W 135	W 150	W 165	W 180
<b>Code</b>	<b>PK45.96E</b>	<b>PK45.97M</b>	<b>PK45.98T</b>	<b>PK45.99Z</b>
ONE	matte			
	glossy			
CLUB				

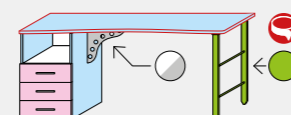

Specify R or L (L in drawing)

	W 135	W 150	W 165	W 180
<b>Code</b>	<b>PK46.17X</b>	<b>PK46.18D</b>	<b>PK46.19L</b>	<b>PK46.20G</b>
ONE	matte			
	glossy			
CLUB				

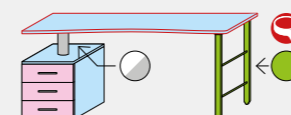

Specify R or L (L in drawing)

	W 135	W 150	W 165	W 180
<b>Code</b>	<b>PK46.37H</b>	<b>PK46.38Q</b>	<b>PK46.39W</b>	<b>PK46.40T</b>
ONE	matte			
	glossy			
CLUB				

Components in **CARCASE** colors  
 Components in **GROUP 2** colors  
 Components in **Types and colors FRONT**

Shaped components available with contrasting edging.  
 B17A GZ8T GV7A CQ3Q B14B BO7H CP4J R87Y CR5T AL1A  
 B17A AL1A  
 B17A

**OPTIONAL:**  
 p. 409
 

- A · Extra colors for Side panels Writing-desk block and Drawer units
- B · Drawers and big drawers with soft-close
- C · Extra colors for Metal leg disc

CLUB  
 drawers and big drawers  
 CHARM with soft-close "Quadro"  
 type slides as standard  
 (without surcharges)

p. 56 Knob and handle positions  
 p. 410 Holes for built-in technology  
 p. 450 Desk accessories

# Corner desks with SG500 shaped top Ht 77.6

## SG500 top Th 2.5

The top is shaped with ABS edging.  
Tops CANNOT be cut to customised.  
Specify R or L (L in drawing).

On request, the top can be fitted with the following built-in technology:

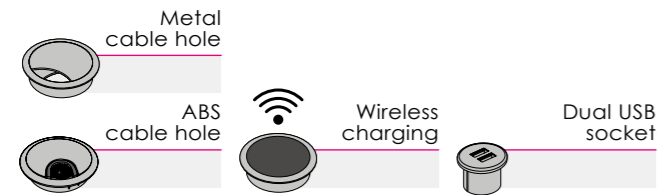

The holes required will be drilled in fixed positions.  
For details, see the chapter "Holes for built-in technology".

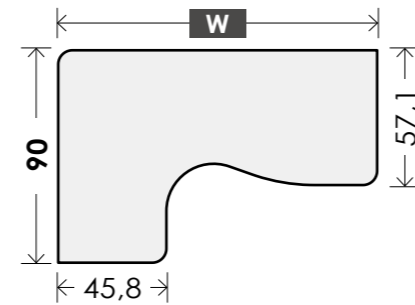

Specify R or L (L in drawing)

	W 135	W 150		
Code	PL30.76W	PL30.77C		



Specify R or L (L in drawing)

	W 135	W 150		
Code	PK46.41Z	PK46.42F		
ONE	matte			
	glossy			
CLUB				

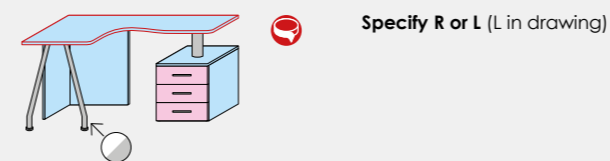

Specify R or L (L in drawing)

	W 135	W 150		
Code	PK46.43N	PK46.44U		
ONE	matte			
	glossy			
CLUB				

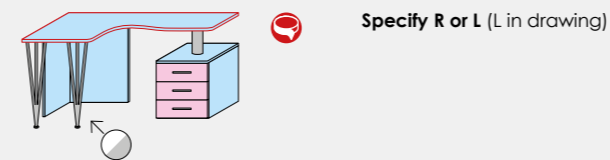

Specify R or L (L in drawing)

	W 135	W 150		
Code	PK46.45A	PK46.46G		
ONE	matte			
	glossy			
CLUB				

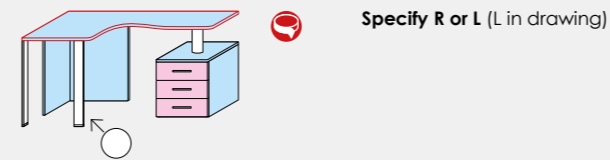

Specify R or L (L in drawing)

	W 135	W 150		
Code	PK46.47P	PK46.48V		
ONE	matte			
	glossy			
CLUB				

**OPTIONAL:** A · Extra colors for Side panels Writing-desk block and Drawer units  
p. 409 B · Drawers and big drawers with soft-close

CLUB  
drawers and big drawers  
CHARM with soft-close "Quadro"  
type slides as standard  
(without surcharges)

p. 56 Knob and handle positions  
p. 410 Holes for built-in technology  
p. 450 Desk accessories



Specify R or L (L in drawing)

	W 135	W 150		
Code	PL30.66R	PL30.67X		

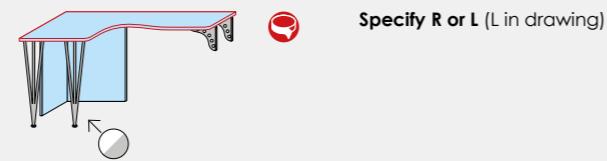

Specify R or L (L in drawing)

	W 135	W 150		
Code	PL30.68D	PL30.69L		



Specify R or L (L in drawing)

	W 135	W 150		
Code	PL30.74H	PL30.75Q		

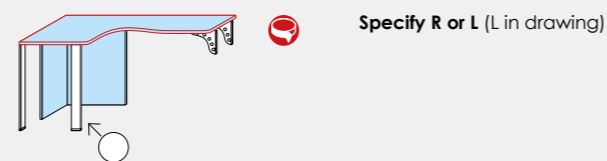

Specify R or L (L in drawing)

	W 135	W 150		
Code	PL30.82A	PL30.83G		



Specify R or L (L in drawing)

	W 135	W 150		
Code	PL30.70G	PL30.71P		

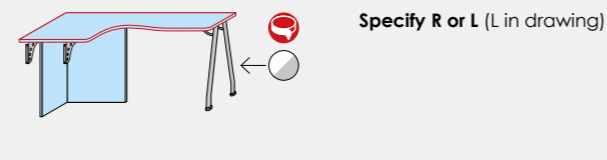

Specify R or L (L in drawing)

	W 135	W 150		
Code	PL30.72V	PL30.73B		

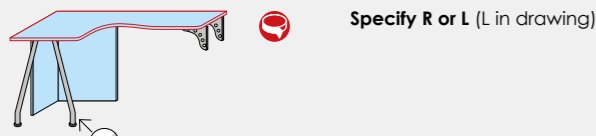

Specify R or L (L in drawing)

	W 135	W 150		
Code	PL30.78K	PL30.79R		



Specify R or L (L in drawing)

	W 135	W 150		
Code	PL30.80N	PL30.81U		

Components in **GROUP 2 colors**  
 Components in **Types and colors FRONT**

Shaped components available with contrasting edging.  
 B17A AL1A  
 B17A



## Peninsulas with SG200 shaped top Ht 77.6 - Dpt 65

### SG200 top Th 2.5

The top is shaped with ABS edging.  
Tops CANNOT be cut to customised.  
Peninsulas W 180 are complete with anti-bending bar.

**Specify R or L** (L in drawing).  
On request, the top can be fitted with the following built-in technology:

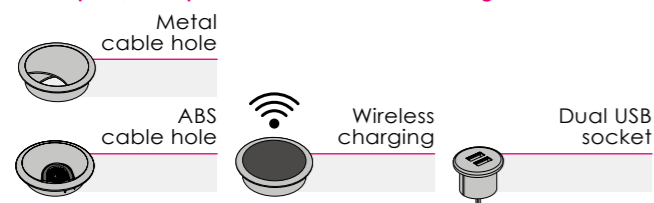

The holes required will be drilled in fixed positions.  
For details, see the chapter "Holes for built-in technology".

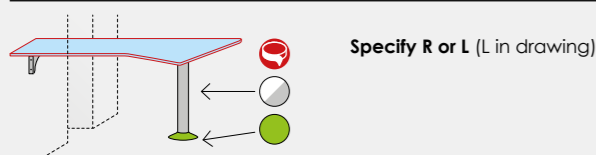
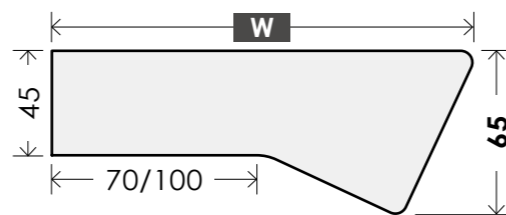

Specify R or L (L in drawing)

	W 150	W 180		
Code	P62.90Y	P62.93Q		
ONE	matte			
	glossy			
CLUB				

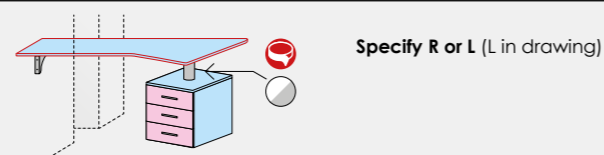

Specify R or L (L in drawing)

	W 150	W 180		
Code	PK46.49B	PK46.50Y		
ONE	matte			
	glossy			
CLUB				

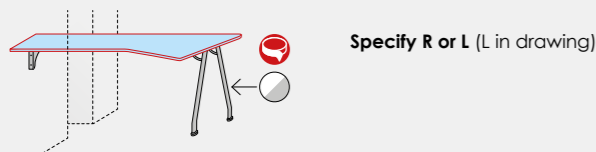

Specify R or L (L in drawing)

	W 150	W 180		
Code	PL30.62Q	PL30.63W		
ONE	matte			
	glossy			
CLUB				

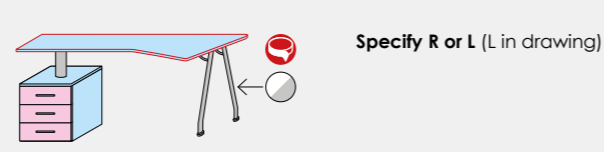

Specify R or L (L in drawing)

	W 150	W 180		
Code	PK46.51E	PK46.52M		
ONE	matte			
	glossy			
CLUB				

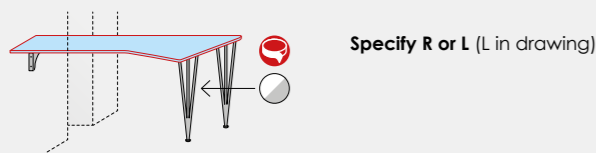

Specify R or L (L in drawing)

	W 150	W 180		
Code	PL48.27P	PL48.28V		
ONE	matte			
	glossy			
CLUB				

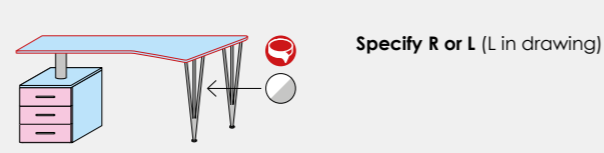

Specify R or L (L in drawing)

	W 150	W 180		
Code	PK46.53T	PK46.54Z		
ONE	matte			
	glossy			
CLUB				

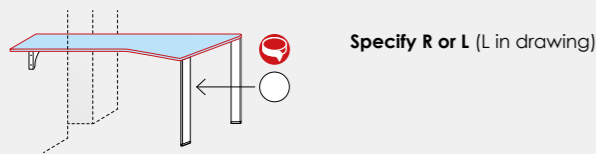

Specify R or L (L in drawing)

	W 150	W 180		
Code	P03.61F	P03.62M		
ONE	matte			
	glossy			
CLUB				



Specify R or L (L in drawing)

	W 150	W 180		
Code	PK46.55F	PK46.56N		
ONE	matte			
	glossy			
CLUB				

Components in **GROUP 2 colors**  
Components in **Types and colors FRONT**



## Peninsulas with SG201 shaped top Ht 77.6 - Dpt 65

### SG201 top Th 2.5

The top is shaped with ABS edging.  
Tops CANNOT be cut to customised.  
Peninsulas W 180 are complete with anti-bending bar.

**Specify R or L** (L in drawing).  
On request, the top can be fitted with the following built-in technology:

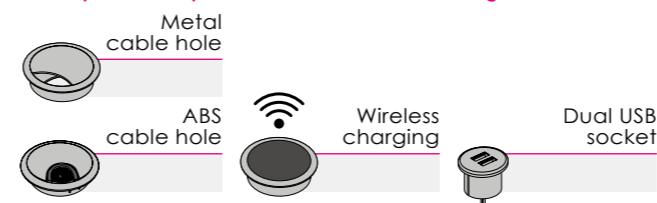

The holes required will be drilled in fixed positions.  
For details, see the chapter "Holes for built-in technology".

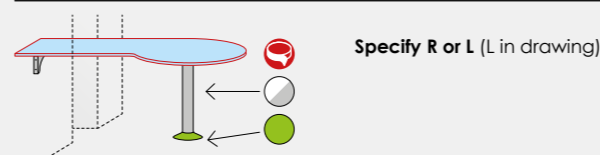
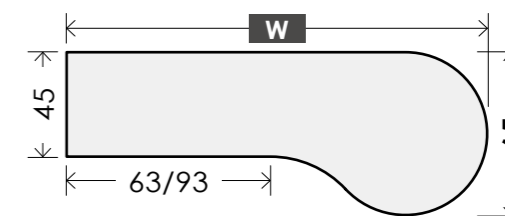

Specify R or L (L in drawing)

	W 150	W 180		
Code	P62.96F	P62.97M		
ONE	matte			
	glossy			
CLUB				

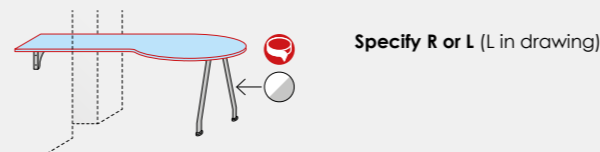

Specify R or L (L in drawing)

	W 150	W 180		
Code	PL30.92F	PL30.93N		
ONE	matte			
	glossy			
CLUB				

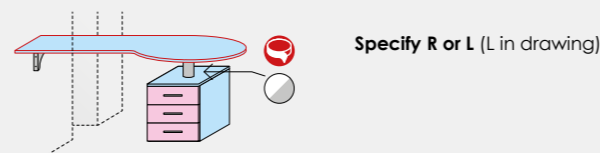

Specify R or L (L in drawing)

	W 150	W 180		
Code	PK46.57U	PK46.58A		
ONE	matte			
	glossy			
CLUB				

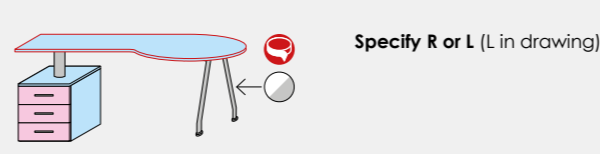

Specify R or L (L in drawing)

	W 150	W 180		
Code	PK46.59G	PK46.60D		
ONE	matte			
	glossy			
CLUB				

**OPTIONAL:**  
p. 409  
A · Extra colors for Side panels Writing-desk block and Drawer units  
B · Drawers and big drawers with soft-close  
C · Extra colors for Metal leg disc

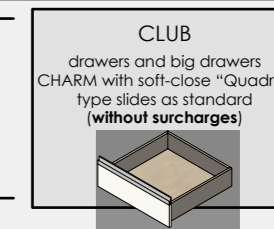

p. 56 Knob and handle positions  
p. 410 Holes for built-in technology  
p. 450 Desk accessories

# Peninsulas with SG400, SG401 and SG402 shaped tops Ht 77.6

Tops CANNOT be cut to customised.  
Specify R or L (L in drawing).

SG400, SG401 and SG402 peninsulas can be applied to KINTAI and IRON loft bed structures and FORMENTERA bunk bed structures.

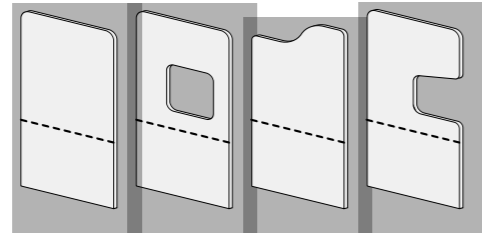

## SG401 top Th 2.5

The top is shaped with ABS edging.

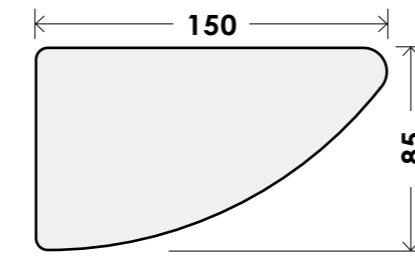

## SG400 top Th 2.5

The top is shaped with ABS edging.

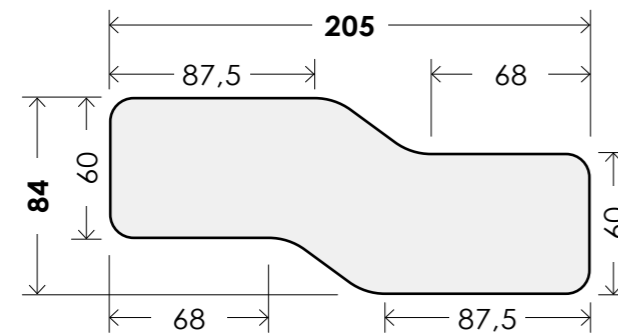

## SG402 top Th 2.5

The top is shaped with ABS edging.



### Desks SG400 Specify R or L (drawing shows L)

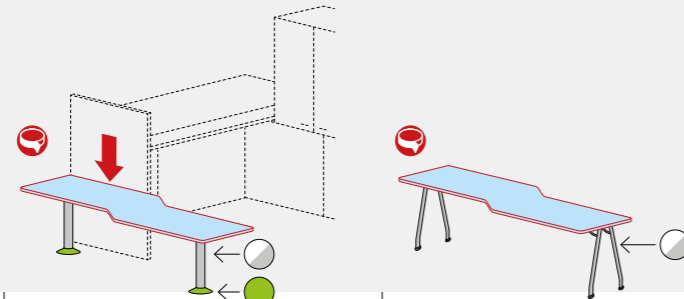

Code	P63.13H	PL30.96G	
------	---------	----------	--

### Desks SG401 Specify R or L (drawing shows L)

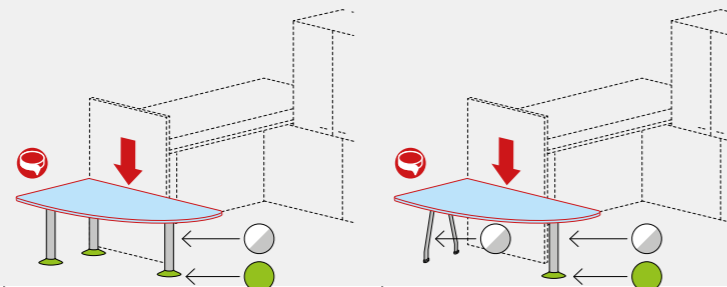

Code	P63.15U	PL30.97P	
------	---------	----------	--

### Desks SG402 Specify R or L (drawing shows L)

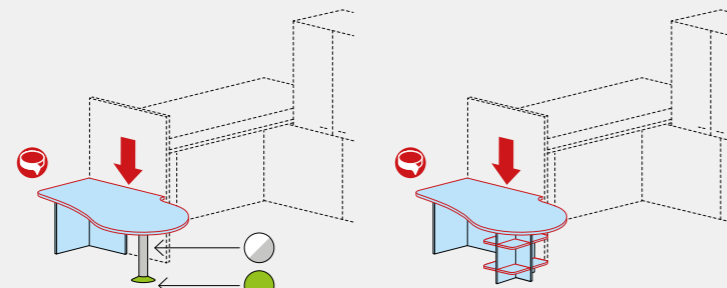

Code	P76.47E	P76.49R	
------	---------	---------	--

Components in **GROUP 2 colors**

Fixing to the side panel with the top supports provided is essential.

Shaped components available with contrasting edging.

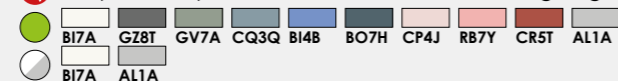

**OPTIONAL:** C - Extra colors for Metal leg disc  
p. 409

CLUB  
drawers and big drawers  
CHARM with soft-close "Quadro"  
type slides as standard  
(without surcharges)



p. 450 Desk accessories

# Shaped tops and bases H 75.1 for desks and peninsulas

## Desk top POLDO Th 2.5

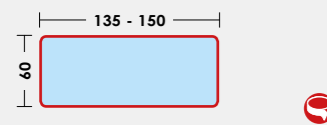

	W 135	W 150				
Code	PL30.98V	PL30.99B				

## Desk top SG100 Th 2.5

Specify R or L (L in drawing)

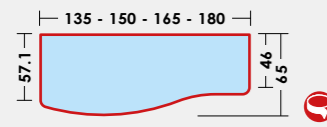

	W 135	W 150	W 165	W 180		
Code	P63.17E	P63.18L	P63.19R	P63.20W		

## Desk top SG101 Th 2.5

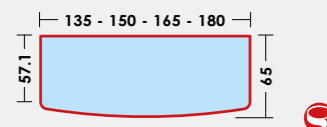

	W 135	W 150	W 165	W 180		
Code	P63.21B	P63.22G	P63.23N	P63.24T		

## Desk top SG102 Th 2.5

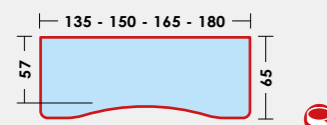

	W 135	W 150	W 165	W 180		
Code	P63.25Y	P63.26D	P63.27K	P63.28Q		

## Corner top SG500 Th 2.5

Specify R or L (L in drawing)

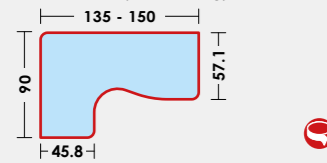

	W 135	W 150				
Code	PL31.00Y	PL31.01E				

## Peninsula top SG200 Th 2.5

Specify R or L (L in drawing)

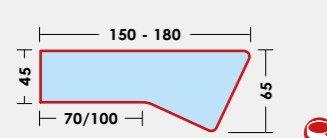

	W 150	W 180				
Code	P63.29V	P63.30A				

## Peninsula top SG201 Th 2.5

Specify R or L (L in drawing)

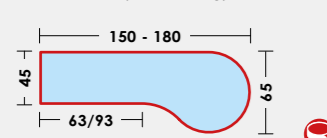

	W 150	W 180				
Code	P63.31F	P63.32M				

	<p>Peninsula top SG400 Th 2.5 Specify R or L (L in drawing)</p>	<p>Peninsula top SG401 Th 2.5 Specify R or L (L in drawing)</p>	<p>Peninsula top SG402 Th 2.5 Specify R or L (L in drawing)</p>
Code	P63.37P	P63.38U	PL31.40V

They have holes (only for the bases in the relevant chapters). Customised cuts are NOT possible. Refer to the technical information in the relevant chapters for built-in technology and the relevant holes (Not on SG400, SG401 and SG402).

- Components in **CARCASE** colors
  - Components in **GROUP 2** colors
  - Components in **Types and colors FRONT**
  - Element complete with lock.
  - Shaped components available with contrasting edging.
- |  |  |  |  |  |  |  |  |  |  |
|--|--|--|--|--|--|--|--|--|--|
|  |  |  |  |  |  |  |  |  |  |
|  |  |  |  |  |  |  |  |  |  |
|  |  |  |  |  |  |  |  |  |  |

## Writing desk blocks

W 45 - Dpt 54.5

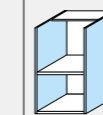

Code

ONE

CLUB

matte

glossy

W 45 - Dpt 56.3

3 drawers Ht 16



4 drawers Ht 16



Specify hinge R or L

1 door Ht 73.2

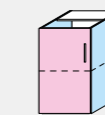

## Drawer units

W 45 - Dpt 45.8

3 drawers Ht 16

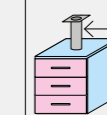

3 drawers Ht 16

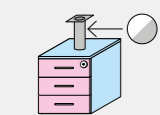

Code	PK46.61L	PK46.62S	PK46.63Y	PK46.64E	PK46.65M	PK46.66T
ONE	matte					
	glossy					
CLUB						

## PC holder

W 25 - Dpt 57.1

Specify R or L (drawing shows L)

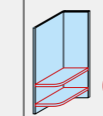

Code

P37.58K

## ELLE supports W 59.6

Specify R or L (drawing shows L)

Dpt 57.1

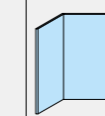

Dpt 45.8

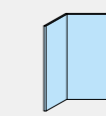

Code	P37.58K	P65.68P	P71.49Z	PL31.03T		
------	---------	---------	---------	----------	--	--

## Shelf block

W 54.9 - Dpt 57.1

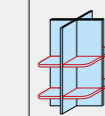

Code	P37.58K	P65.68P	P71.49Z	PL31.03T		
------	---------	---------	---------	----------	--	--

## Metal leg

Ø 8

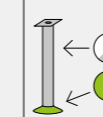

Code

P28.86N

## POP leg

W 20 - Dpt 43.3

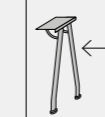

Code

P07.98V

## TRIS leg

W 11.8

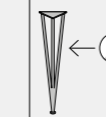

Code

P07.28Q

## SLIM leg

W 7 - Th 2

Not recommended for use with SG201, SG400, SG401 and SG402 tops.

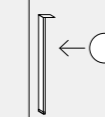

Code

P03.00Z

## BIT leg

Th 2.5 - Dpt 46

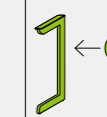

Code

P08.02B

## HEY leg

W 5 - Dpt 43.5

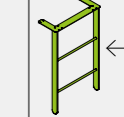

Code

PK46.67Z

Code	P28.86N	P07.98V	P07.28Q	P03.00Z	P08.02B	PK46.67Z
------	---------	---------	---------	---------	---------	----------

## Top support

Ht 20 - W 20

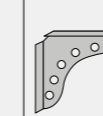

Code

P36.97T

## Stiffener bars for tops 165 - 180

Dpt 8 - W 105

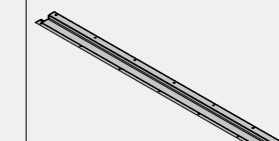

Code

P39.40T

Code	P36.97T	P39.40T				
------	---------	---------	--	--	--	--



**OPTIONAL:**  
p. 409

- A · Extra colors for Side panels Writing-desk block and Drawer units
- B · Drawers and big drawers with soft-close
- C · Extra colors for Metal leg disc

CLUB

drawers and big drawers CHARM with soft-close "Quadro" type slides as standard (without surcharges)



- p. 56 Knob and handle positions
- p. 410 Holes for built-in technology
- p. 450 Desk accessories

# LINEA writing desks with unfinished back panel

## Ht 77.6 - Dpt 57.1/45.8

### LINEA top Th 2.5

On request, the top can be fitted with the following built-in technology:

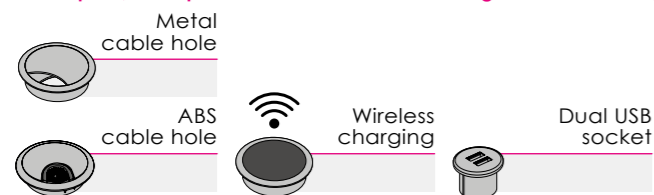

The holes required will be drilled in fixed positions. For details, see the chapter "Holes for built-in technology".

\* The integrated technology will not be available when the length of the desk is equal to or less than 122 cm.

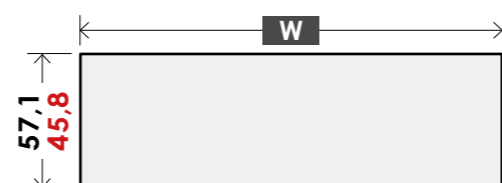

Specify R or L (L in drawing)

		custom-made Min 90 Max 220	
	<b>Code</b>	<b>PK46.74L</b> * *	
ONE	matte		
	glossy		
CLUB			

Specify R or L (L in drawing)

		135	
	<b>Code</b>	<b>PK46.78M</b>	
ONE	matte		
	glossy		
CLUB			

Specify R or L (L in drawing)

		custom-made Min 90 Max 220	
	<b>Code</b>	<b>PK46.75S</b> * *	
ONE	matte		
	glossy		
CLUB			

Specify R or L (L in drawing)

		135	
	<b>Code</b>	<b>PK46.79T</b>	
ONE	matte		
	glossy		
CLUB			

Specify R or L (L in drawing)

		custom-made Min 90 Max 220	
	<b>Code</b>	<b>PK46.76Y</b> * *	
ONE	matte		
	glossy		
CLUB			

Specify R or L (L in drawing)

		90	
	<b>Code</b>	<b>P04.62Q</b>	
ONE	matte		
	glossy		
CLUB			

Specify R or L (L in drawing)

		custom-made Min 135 Max 220	
	<b>Code</b>	<b>PK46.77E</b>	
ONE	matte		
	glossy		
CLUB			

Specify R or L (L in drawing)

	<b>Code</b>	<b>P04.69C</b> *	
ONE	matte		
	glossy		
CLUB			

		custom-made Min 45 Max 220	
	<b>Code</b>	<b>P04.47H</b>	
	<b>Code Dpt 45.8</b>	<b>P04.68X</b>	

Specify R or L (L in drawing)

		custom-made Min 90 Max 220	
	<b>Code</b>	<b>PK46.70K</b> * *	
ONE	matte		
	glossy		
CLUB			

Specify R or L (L in drawing)

		custom-made Min 90 Max 220	
	<b>Code</b>	<b>PK46.68F</b> *	
ONE	matte		
	glossy		
CLUB			

Specify R or L (L in drawing)

		custom-made Min 90 Max 220	
	<b>Code</b>	<b>PK46.71R</b> * *	
ONE	matte		
	glossy		
CLUB			

Specify R or L (L in drawing)

		custom-made Min 90 Max 220	
	<b>Code</b>	<b>PK46.69N</b> * *	
ONE	matte		
	glossy		
CLUB			

Specify R or L (L in drawing)

		custom-made Min 90 Max 220	
	<b>Code</b>	<b>PK46.72X</b> *	
ONE	matte		
	glossy		
CLUB			

### • Elements for composing LINEA writing desks

Melamine-coated tops Dpt 57.1 Th 2.5	Top custom-made Max 360 Min 30	R countertop for corner custom-made Max 360 Min 2.8	R top for corner custom-made Max 360 Min 61	L top for corner custom-made Max 360 Min 61	L countertop for corner custom-made Max 360 Min 2.8
<b>Code</b>	<b>PL48.62C</b>	<b>PL48.63K</b>	<b>PL48.64R</b>	<b>PL48.65X</b>	<b>PL48.66D</b>

Metal leg Ht 75.1 - Ø 8	TRIS leg Ht 75.1 - W 11.8	SLIM leg Ht 75.1 - W 7 - Th 2	Top support Ht 20 - W 20	Stiffener bars for tops 165 - 180 Dpt 8 - W 105
<b>Code</b>	<b>P28.86N</b>	<b>P07.28Q</b>	<b>P03.00Z</b>	<b>P36.97T</b>
			<b>P36.97T</b>	<b>P39.40T</b>

Writing-desk structure custom-made Min 45 Max 220 Specify R or L (drawing shows R)	Writing-desk back panel Custom-made Min 45 Max 220	Writing-desk structure with drawer Ht 8 Specify R or L (drawing shows R)	Writing-desk back panel with drawer Ht 8	PC case holder W 25 - Dpt 54.5
<b>Code</b>	<b>P04.72U</b>	<b>P04.73Z</b>	<b>P04.70H</b>	<b>PK46.73D</b>
ONE	matte			
	glossy			
CLUB				

Writing desk blocks W 45 - Dpt 54.5	W 45 - Dpt 56.3 3 drawers Ht 16	4 drawers Ht 16	Specify hinge R or L 1 door Ht 73.2	Empty corner filler strip Ht 75.1 - W 5.4 x 5.4
<b>Code</b>	<b>PK46.61L</b>	<b>PK46.62S</b>	<b>PK46.63Y</b>	<b>PK46.64E</b>
				<b>Code</b>
				<b>P37.48E</b>

Components in **CARCASE** colors  
 Components in **GROUP 2** colors  
 Components in **Types and colors FRONT**

B17A  
 GZ8T  
 GV7A  
 CQ3Q  
 B14B  
 BO7H  
 CP4J  
 R87Y  
 CR5T  
 AL1A  
 B17A  
 B17A



**OPTIONAL:**  
p. 409

- A · Extra colors for Side panels Writing-desk block and Drawer units
- B · Drawers and big drawers with soft-close
- C · Extra colors for Metal leg disc

**CLUB**  
drawers and big drawers  
CHARM with soft-close "Quadro"  
type slides as standard  
(without surcharges)



p. 56 Knob and handle positions  
p. 410 Holes for built-in technology  
p. 450 Desk accessories

## ANCORA desks Ht 77.6 - Dpt 60

### ANCORA top Th 2.5

The top is shaped with ABS edging.  
Tops CANNOT be cut to customised.

On request, the top can be fitted with the following built-in technology:

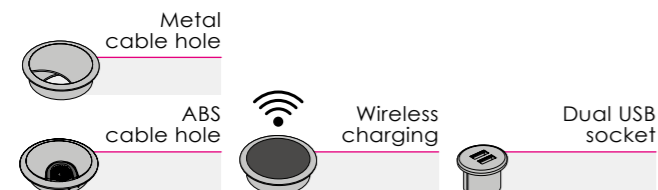

The holes required will be drilled in fixed positions.  
For details, see the chapter "Holes for built-in technology".

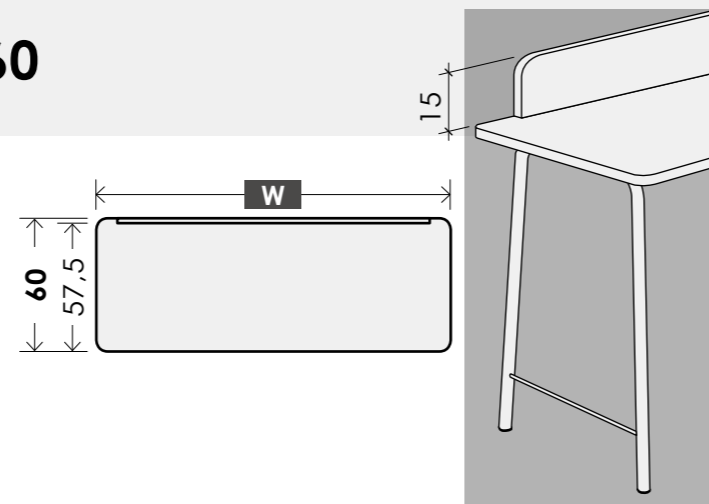

## TWIG desks Ht 77.6 - Dpt 60

### TWIG top Th 2.5

The top is shaped with ABS edging.  
Tops CANNOT be cut to customised.  
Legs in solid natural ash wood with adjustable feet.

On request, the top can be fitted with the following built-in technology:

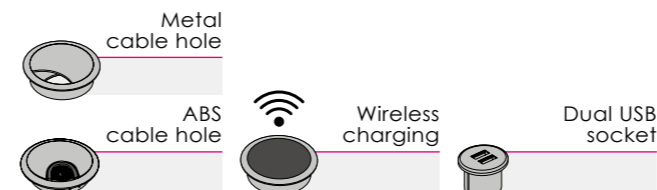

The holes required will be drilled in fixed positions.  
For details, see the chapter "Holes for built-in technology".

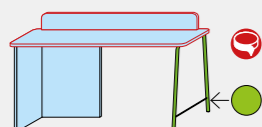
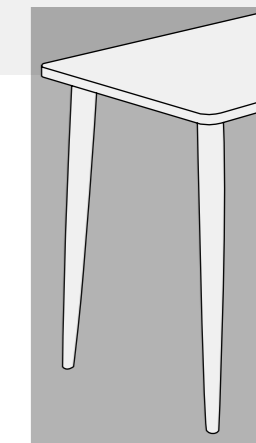
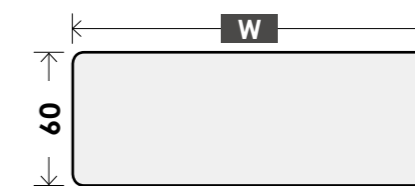

Specify R or L (L in drawing)

	W 135	W 150		
Code	PK47.15P	PK47.16V		
ONE	matte			
	glossy			
CLUB				

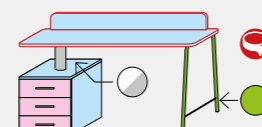

Specify R or L (L in drawing)

	W 135	W 150		
Code	PK47.23F	PK47.24N		
ONE	matte			
	glossy			
CLUB				



Specify R or L (L in drawing)

	W 135	W 150		
Code	PK46.88S	PK46.89Y		
ONE	matte			
	glossy			
CLUB				

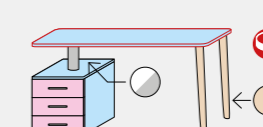

Specify R or L (L in drawing)

	W 135	W 150		
Code	PK46.96K	PK46.97R		
ONE	matte			
	glossy			
CLUB				

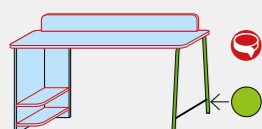

Specify R or L (L in drawing)

	W 135	W 150		
Code	PK47.17B	PK47.18H		
ONE	matte			
	glossy			
CLUB				

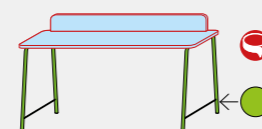

Specify R or L (L in drawing)

	W 135	W 150		
Code	PK47.25U	PK47.26A		
ONE	matte			
	glossy			
CLUB				

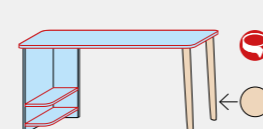

Specify R or L (L in drawing)

	W 135	W 150		
Code	PK46.90V	PK46.91B		
ONE	matte			
	glossy			
CLUB				



Specify R or L (L in drawing)

	W 135	W 150		
Code	PK46.98X	PK46.99D		
ONE	matte			
	glossy			
CLUB				

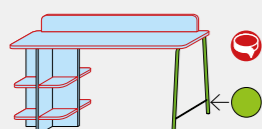

Specify R or L (L in drawing)

	W 135	W 150		
Code	PK47.19Q	PK47.20M		
ONE	matte			
	glossy			
CLUB				

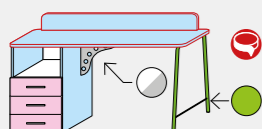

Specify R or L (L in drawing)

	W 135	W 150		
Code	PK47.21T	PK47.22Z		
ONE	matte			
	glossy			
CLUB				

#### Accessories in metal for backguard

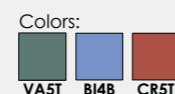

#### Paper holder

Ht 5,2  
Dpt 21  
W 30

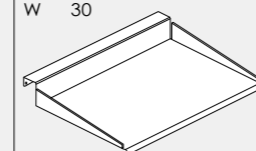

Code **PK47.27G**

#### Pen holder

Ht 11  
Dpt 7,8  
W 7,5

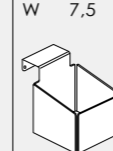

Code **PK47.28P**

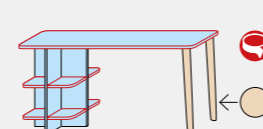

Specify R or L (L in drawing)

	W 135	W 150		
Code	PK46.92H	PK46.93Q		
ONE	matte			
	glossy			
CLUB				

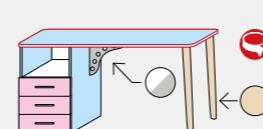

Specify R or L (L in drawing)

	W 135	W 150		
Code	PK46.94W	PK46.95C		
ONE	matte			
	glossy			
CLUB				



**OPTIONAL:** A · Extra colors for Side panels Writing-desk block and Drawer units  
p. 409 B · Drawers and big drawers with soft-close

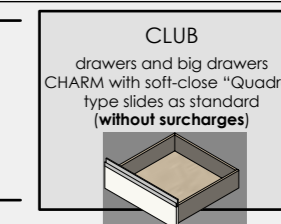

CLUB  
drawers and big drawers  
CHARM with soft-close "Quadro"  
type slides as standard  
(without surcharges)



p. 56 Knob and handle positions  
p. 410 Holes for built-in technology  
p. 450 Desk accessories

- Components in **CARCASE** colors
- Components in **GROUP 2** colors
- Components in **Types and colors FRONT**

- Shaped components available with contrasting edging.
- BI7A
- GZ8T
- GV7A
- CQ3Q
- BI4B
- BO7H
- CP4J
- R87Y
- CR5T
- AL1A
- BI7A
- AL1A
- Solid natural ash wood

Wood is a natural product and, as such, is subject to variations in color and grain. Differences in grain or color therefore do not constitute grounds for dispute.



# FLY desks Ht 77.6 - Dpt 57.1

## FLY top Th 2.5

Desks W 165 and W 180 are complete with anti-bending bar.  
**On request, the top can be fitted with the following built-in technology:**

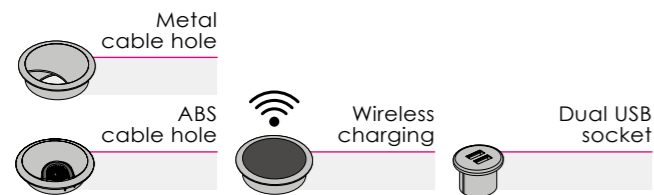

The holes required will be drilled in fixed positions.  
**For details, see the chapter "Holes for built-in technology".**

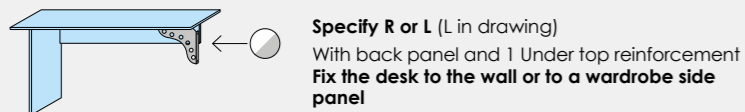
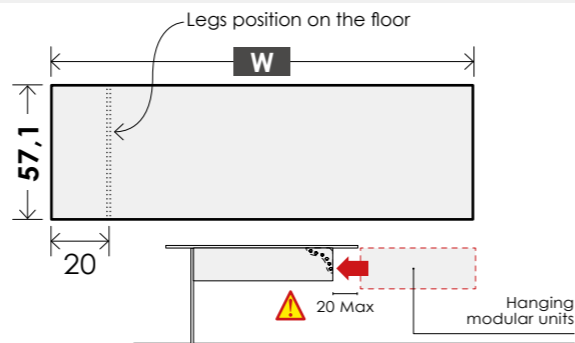

**Specify R or L** (L in drawing)  
 With back panel and 1 Under top reinforcement  
**Fix the desk to the wall or to a wardrobe side panel**

	W 135	W 150	W 165	W 180
<b>Code</b>	<b>PL31.04Z</b>	<b>PL31.05F</b>	<b>PL31.06N</b>	<b>PL31.07U</b>

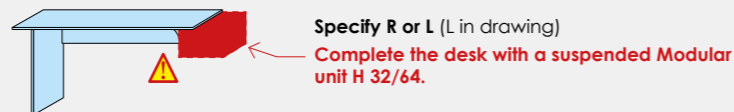

**Specify R or L** (L in drawing)  
**Complete the desk with a suspended Modular unit H 32/64.**

	W 135	W 150	W 165	W 180
<b>Code</b>	<b>PL31.08A</b>	<b>PL31.09G</b>	<b>PL31.10D</b>	<b>PL31.11L</b>

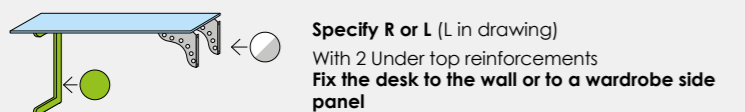

**Specify R or L** (L in drawing)  
 With 2 Under top reinforcements  
**Fix the desk to the wall or to a wardrobe side panel**

	W 135	W 150	W 165	W 180
<b>Code</b>	<b>PL31.12S</b>	<b>PL31.13Y</b>	<b>PL31.14E</b>	<b>PL31.15M</b>

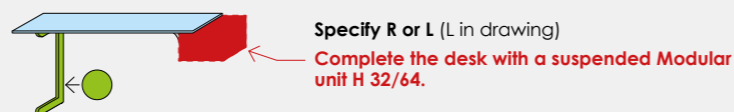

**Specify R or L** (L in drawing)  
**Complete the desk with a suspended Modular unit H 32/64.**

	W 135	W 150	W 165	W 180
<b>Code</b>	<b>PL31.16T</b>	<b>PL31.17Z</b>	<b>PL31.18F</b>	<b>PL31.19N</b>

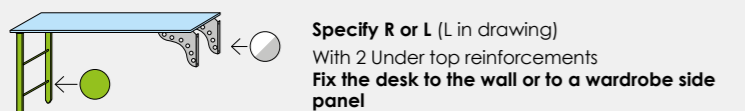

**Specify R or L** (L in drawing)  
 With 2 Under top reinforcements  
**Fix the desk to the wall or to a wardrobe side panel**

	W 135	W 150	W 165	W 180
<b>Code</b>	<b>PK46.80Q</b>	<b>PK46.81W</b>	<b>PK46.82C</b>	<b>PK46.83K</b>

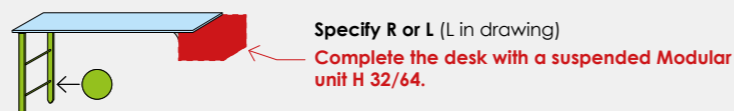

**Specify R or L** (L in drawing)  
**Complete the desk with a suspended Modular unit H 32/64.**

	W 135	W 150	W 165	W 180
<b>Code</b>	<b>PK46.84R</b>	<b>PK46.85X</b>	<b>PK46.86D</b>	<b>PK46.87L</b>

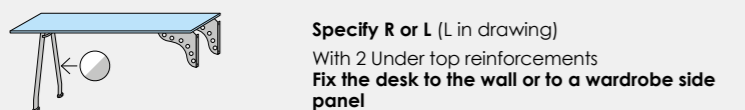

**Specify R or L** (L in drawing)  
 With 2 Under top reinforcements  
**Fix the desk to the wall or to a wardrobe side panel**

	W 135	W 150	W 165	W 180
<b>Code</b>	<b>PL31.28M</b>	<b>PL31.29T</b>	<b>PL31.30Q</b>	<b>PL31.31W</b>

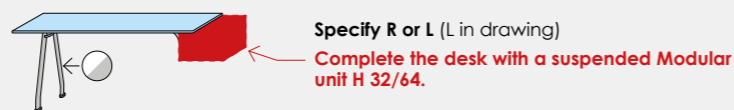

**Specify R or L** (L in drawing)  
**Complete the desk with a suspended Modular unit H 32/64.**

	W 135	W 150	W 165	W 180
<b>Code</b>	<b>PL31.32C</b>	<b>PL31.33K</b>	<b>PL31.34R</b>	<b>PL31.35X</b>

Components in **GROUP 2 colors**  
 Components in **Types and colors FRONT**

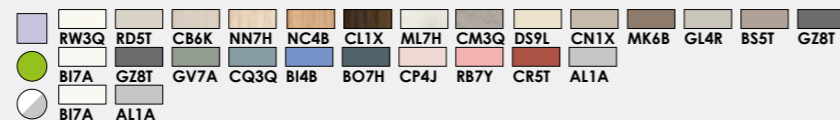

# LOFT desks Ht 75 - Dpt 59.7

## LOFT top Th 1.8

The top is squared at front and back.  
 Tops CANNOT be cut to customised.  
 Bianco opaco (B17A), Grigio titanio (GZ8T) or Alluminio (AL5Z) colour metal frame.

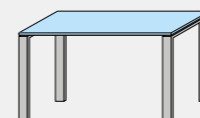
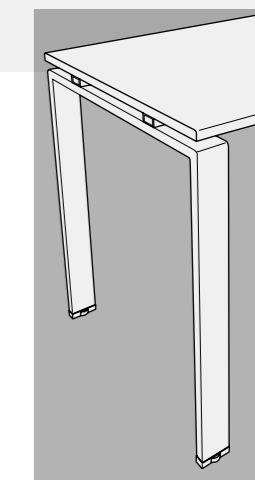
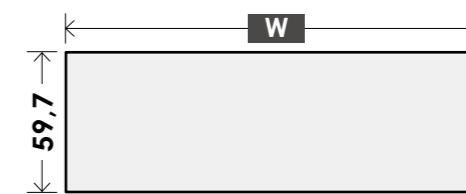

	W 100	W 120	W 140	W 180		
<b>Code</b>	<b>P76.52G</b>	<b>P76.53N</b>	<b>P76.54T</b>	<b>P76.55Y</b>		
	363,00	374,00	380,00	398,00		

# ROUND desks Ht 72 - Dpt 45.6

## Swivel top and side Th 5.5

Modular element W 90 complete with ALFA-25 feet.  
 Custom cuts are not possible.  
 The swivel top can support a max load of 30 Kg, evenly distributed.

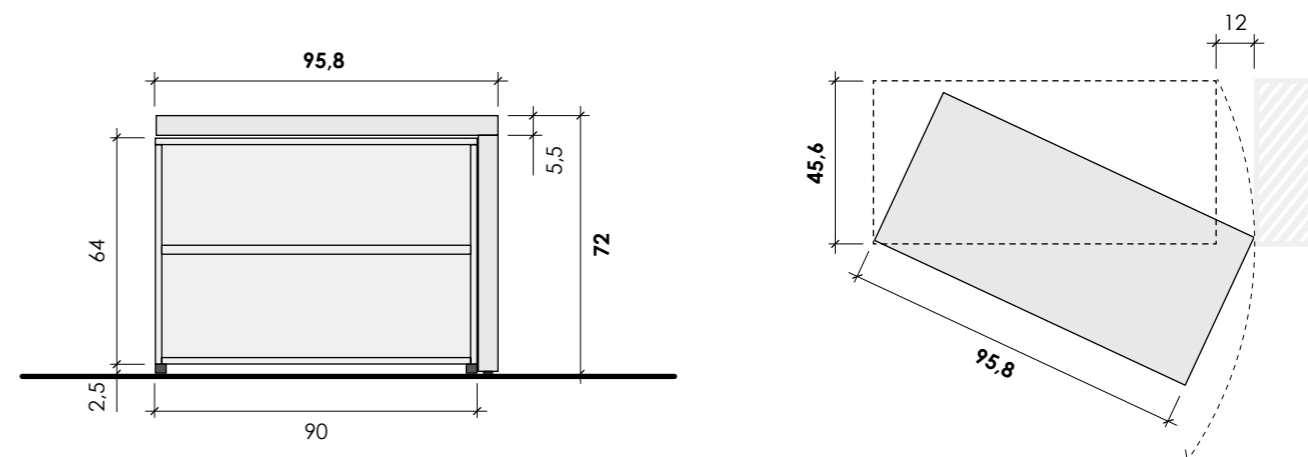

### ROUND with open compartments

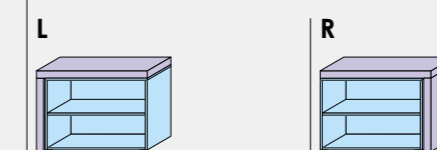

**Code** **PK47.29V** **PK47.30S**

ONE	matte			
	glossy			
CLUB				

### ROUND with open compartment and big drawers

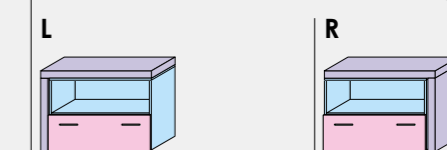

**Code** **PK47.31Y** **PK47.32E**

ONE				
CLUB				

**CLUB**  
 drawers and big drawers  
 CHARM with soft-close "Quadro"  
 type slides as standard  
 (without surcharges)

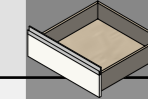



# PODIO desks Dpt 49

## PODIO

We recommend positioning the desk top at a maximum height of 77 cm from the floor.  
Adjustable support brackets for wall fixing are included.  
Maximum load recommended: 60 Kg.  
Element can not be modified.

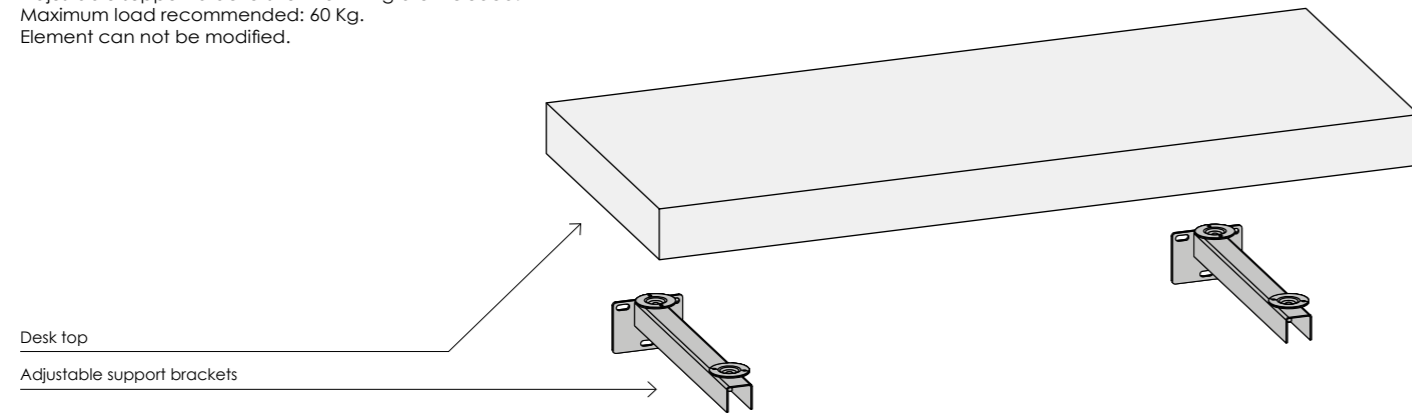

On request, the top can be fitted with the following built-in technology:

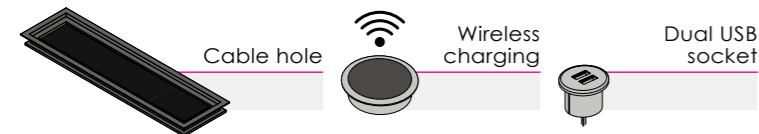

The holes required will be drilled in fixed positions.  
For details, see the chapter "Holes for built-in technology".

## PODIO desks

Ht 8  
Dpt 49

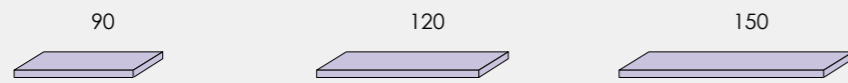

Code	PL48.95P	PL48.96V	PL48.97B	
------	----------	----------	----------	--

## Back panel

Wall fixing with the provided hardware.

Ht 27,5  
Th 1,8

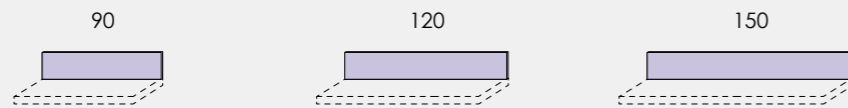

Code	PL48.81G	PL48.82P	PL48.83V	
------	----------	----------	----------	--

Components in **GROUP 2 colors**  
 RW3Q RD5T CB6K NN7H NC4B CL1X ML7H CM3Q DS9L CN1X MK6B GL4R BS5T GZ8T  
 Shaped components available with contrasting edging.

# EVO desk Ht 90,5 - Dpt 50

## EVO

Desk with adjustable top with three predefined heights.  
Made entirely of Th 2.5 cm panels.

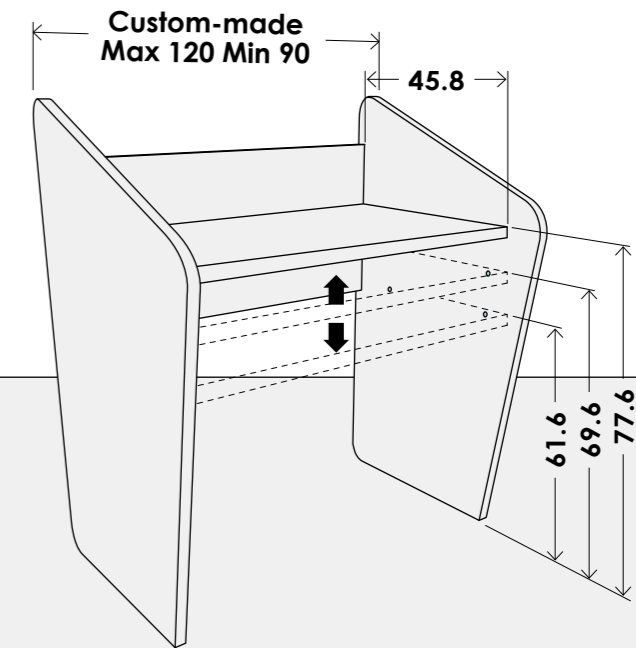

W custom-made (min 90 - max 120)

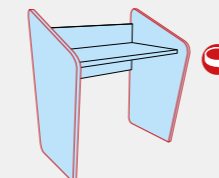

Code	PL48.57E			
------	----------	--	--	--

# BAIA desk Ht 99.3 - Dpt 54

## BAIA

Entirely made up of Th 2.5 panels.



## Desks

Ht 99,3  
Dpt 60,8  
W 135

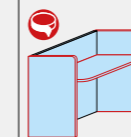

W 150

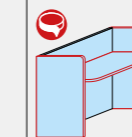

W 165

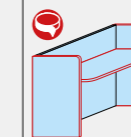

W 180

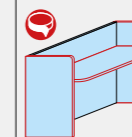

## Metal accessories for BAIA desk

### Paper holder

Ht 5,2  
Dpt 21  
W 30

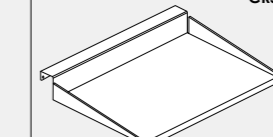

### Pen holder

Ht 11  
Dpt 7,8  
W 7,5

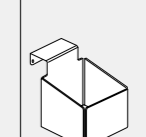

Code	PK53.50P	PK53.51V	PK53.52B	PK53.53H	PK47.27G	PK47.28P
------	----------	----------	----------	----------	----------	----------

# Custom-made shaped tops WITHOUT HOLES for assembly

Supporting elements are proportional to the size of the top.

Supporting elements are proportional to the size of the top.

**Examples**

<b>Code</b>	<b>P39.43K</b>
-------------	----------------

**L examples**

<b>Code</b>	<b>P37.76G</b>
-------------	----------------

Supporting elements are proportional to the size of the top.

Supporting elements are proportional to the size of the top. **The 2 straight sides must always be the same length.**

**Examples are R**

<b>Code</b>	<b>P48.11K</b>
-------------	----------------

**R examples**

<b>Code</b>	<b>P95.30P</b>
-------------	----------------

**Examples**

<b>Code</b>	<b>P48.12Q</b>
-------------	----------------

Supporting elements Ht 75.1	Metal leg	POP leg	TRIS leg	SLIM leg	BIT leg	HEY leg
Supporting elements are proportional to the size of the top.	Ø 8 (Base Ø 23) Fixing plates W 12 x 12	W 20 - Dpt 43.3 Fixing plates W 20 x 40	W 11.8 Fixing plates W 11.8 x 10.5	W 7 - Th 2 Fixing plates W 18 x 6	Th 2.5 - Dpt 46 Fixing plates W 5.7 x 46	W 5 - Dpt 45.5 Fixing plates W 5.7 x 46
<b>Code</b>	<b>P28.86N</b>	<b>P07.98V</b>	<b>P07.28Q</b>	<b>P03.00Z</b>	<b>P08.02B</b>	<b>PK46.67Z</b>
<b>Code</b>	<b>PK47.34T</b>	<b>PK47.33M</b>	<b>P36.97T</b>	<b>P39.40T</b>		

**OPTIONAL:** C - Extra colors for Metal leg disc  
p. 409

- Shaped tops Th 2.5 with ABS edging.
- Without holes or prefitted hardware.
- It is essential to send a drawing.

**R = The radius of curvature cannot be changed**

Components in **GROUP 2 colors**

Shaped components available with contrasting edging.



**Solid natural ash wood**  
Wood is a natural product and, as such, is subject to variations in color and grain. Differences in grain or color therefore do not constitute grounds for dispute.

# Designed shaped panels Th 2.5

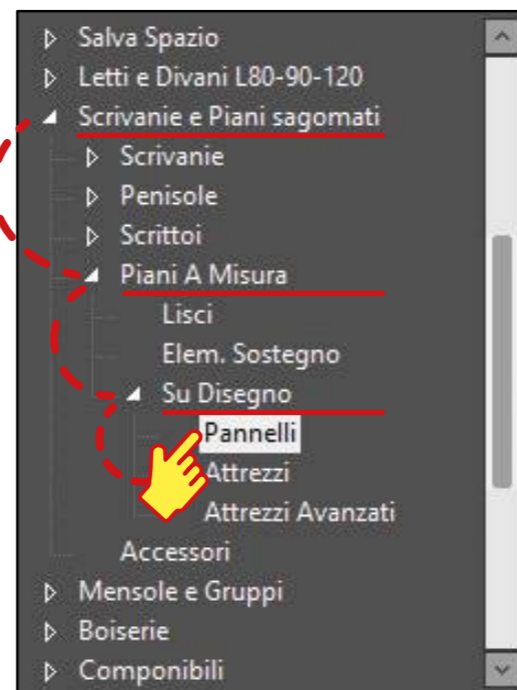
- Customer designed shaped panels are produced with the technical department's approval.
- Our graphics program, "METRON 4", slides you step-by-step in creating the shaped top (see point 1) and automatically calculates the price of the panel (see point 4).
- Tops with sizes and curves are created based on the limits indicated below (see points 2 and 3).
- One side of the panel is always straight (see point 2).

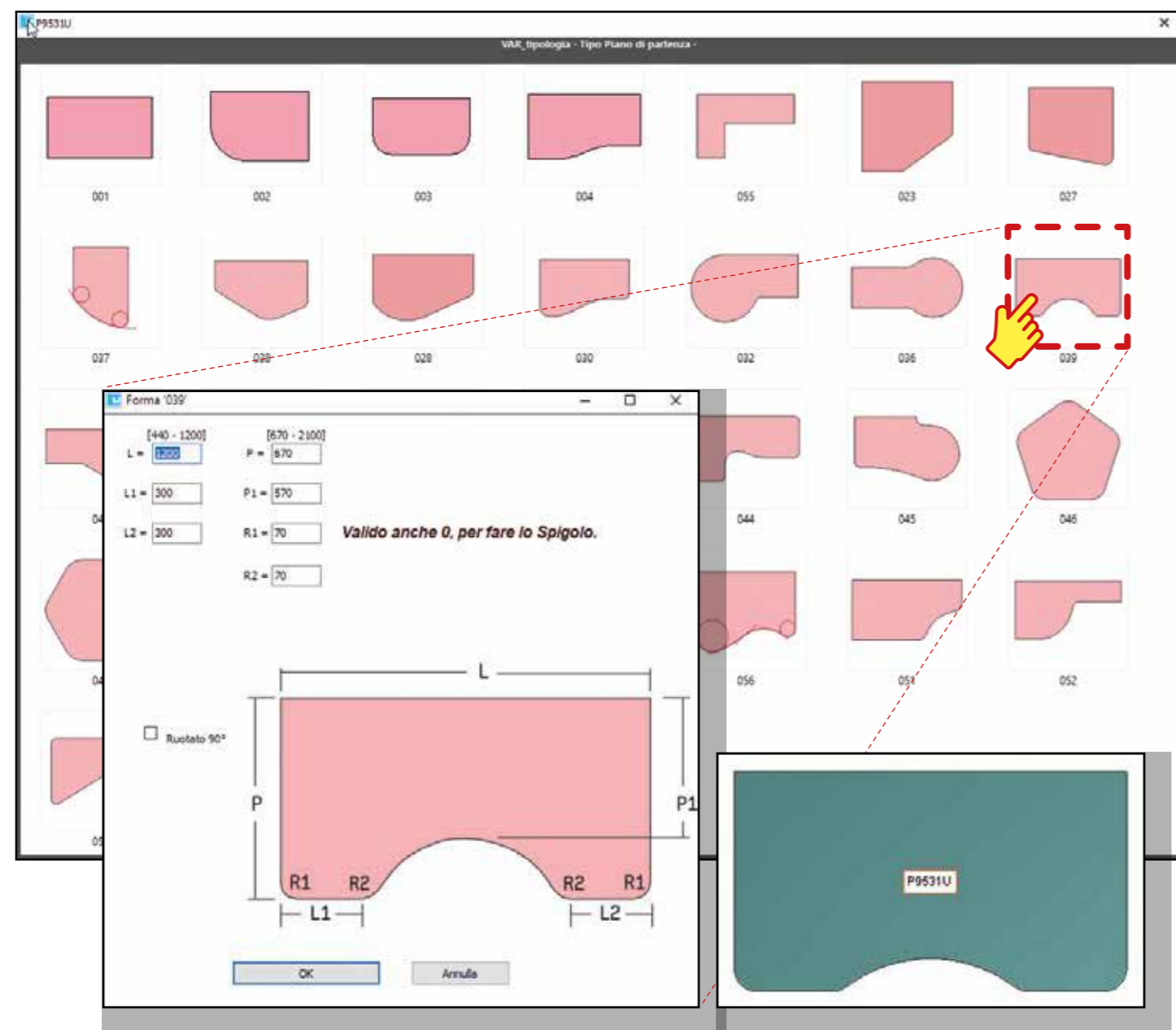

## 1) Order example METRON 4.



## 2) The panel area will never exceed 2.52 square meters (2.10 x 1.20).

Examples:

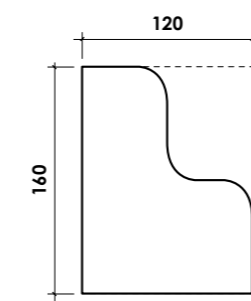

Example:  
 1.60 m x  
 1.20 m =  
 1.92 m<sup>2</sup>

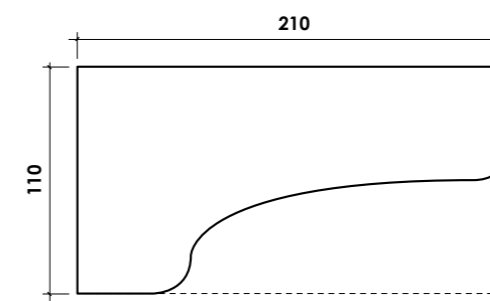

Example:  
 2.10 m x  
 1.10 m =  
 2.31 m<sup>2</sup>

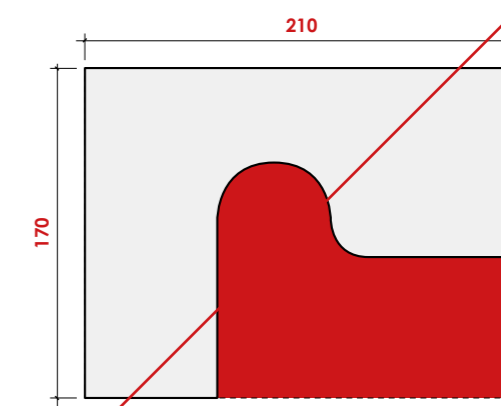

Example:  
 2.10 m x  
 1.70 m =  
 3.57 m<sup>2</sup>

**NO**

## 3) Minimum radius of curvature.

Examples:

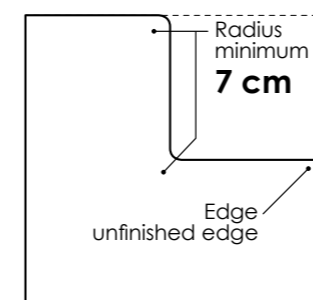

If you cut the worktop the sides will be without edge

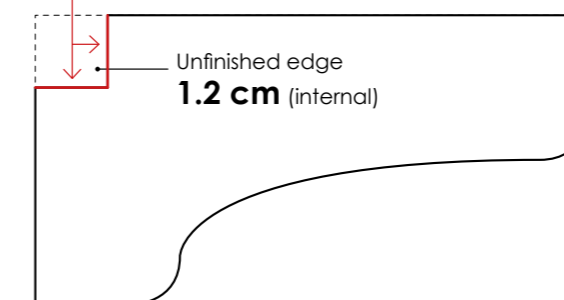

Holes of any diameter or round shapes are NOT provided.

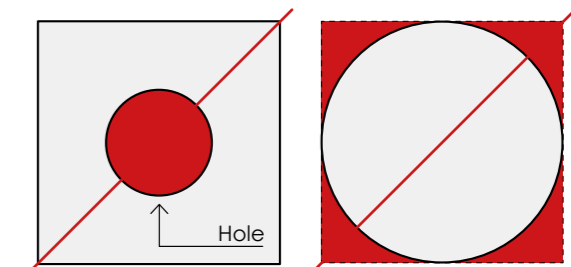

## 4) Calculating the price of shaped panels to the customer's design.

The price of shaped panels to the customer's design is calculated per square metre, considering the amount of board needed to produce the custom panel.

Example:

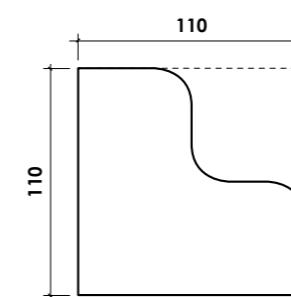

m 1,10 x  
 m 1,10 =  
 m<sup>2</sup> 1,21 x

	VERTICAL vein pattern	HORIZONTAL vein pattern
<b>Panels for shaping</b>	Max 120 Min 44 Max 210 Min 67	Max 120 Min 44 Max 180 Min 67
<b>Code</b>	<b>P95.31U</b>	<b>P95.32Z</b>

- Components in **GROUP 2** colors
- Shaped components available with contrasting edging.

# Desk accessories

## Drawer units with finished back panel on wheels

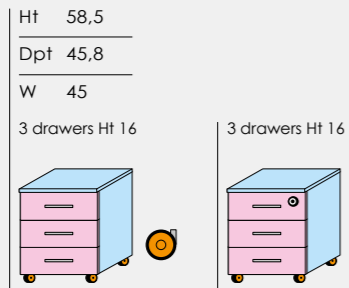

<b>Code</b>	<b>PK47.01G</b>	<b>PK47.02P</b>				
ONE	matte					
	glossy					
CLUB						

## Drawer units POLDO Dpt 53 Ht 43.5

At your discretion you can assemble H 8 castor wheels (Ht 48 total).

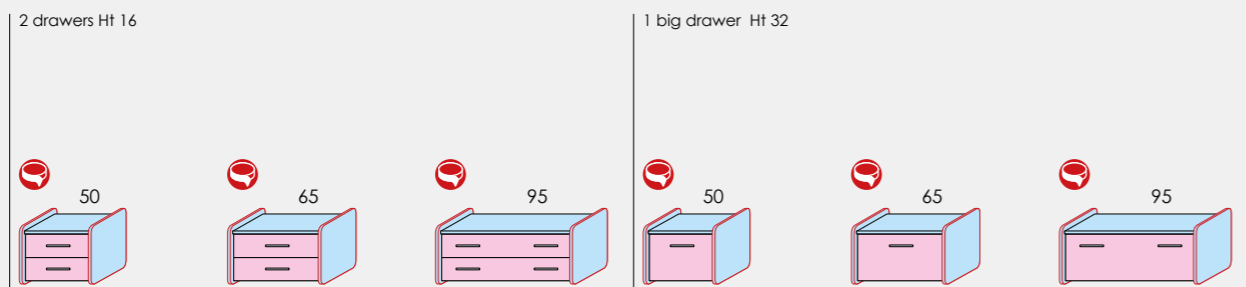

<b>Code</b>	<b>PL38.00D</b>	<b>PL38.01L</b>	<b>PL38.02S</b>	<b>PL38.03Y</b>	<b>PL38.04E</b>	<b>PL38.05M</b>
ONE	matte					
	glossy					
CLUB						

## Baskets POLDO Dpt 53 Ht 43.5

At your discretion you can assemble H 8 castor wheels (Ht 48 total).

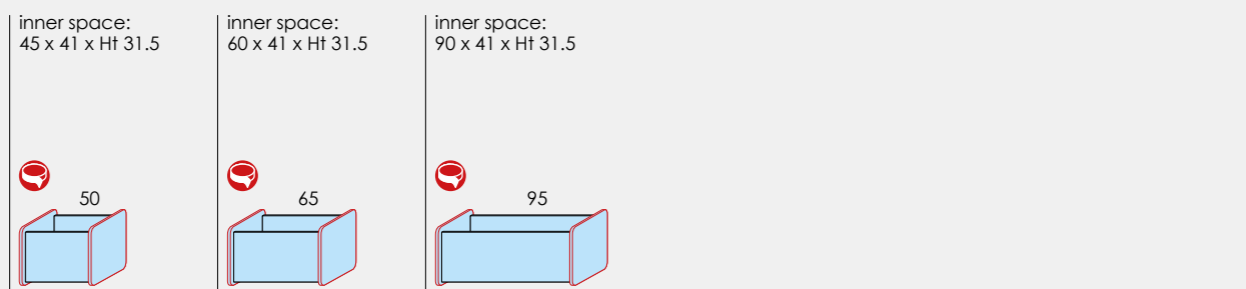

<b>Code</b>	<b>PL38.06T</b>	<b>PL38.07Z</b>	<b>PL38.08F</b>			
-------------	-----------------	-----------------	-----------------	--	--	--

- Components in **GROUP 2 colors**
- Components in **Types and colors FRONT**
- Aluminium colour components
- Unit with lock.
- \* Not applicable to the LOFT and SG500 desks.

Shaped components available with contrasting edging.

	BT4R	OR1S	RO3R	RS8X	VE5R	MN4K	BL6R	AR3T	BN7A	AR3T	<span style="color: #E91E63;">*</span> With brake			
	BI7A	AL1A												
	BI7A													
	FABRIC JENNY	0402	0403	0503	0900	0903	0905	0314	0303	0805	0706	0704	0601	0604
	FABRIC KENYA	0014	0013	0016	0020	0019								

## SPICCHIO screen holder

Ht 18  
Dpt 54,5  
W 54,5

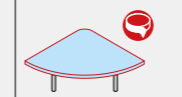

<b>Code</b>	<b>P38.27U</b>	<b>P39.99P</b>	<b>P37.46U</b>	<b>P07.72D</b>	<b>P00.64N</b>
-------------	----------------	----------------	----------------	----------------	----------------

## Pen holder for drawer

Ht 3  
Dpt 20  
W 36

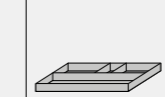

## Pull-out keyboard shelf (for underneath top)

Ht 6  
Dpt 29,5  
W 59

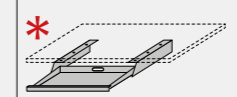

## Castor wheels

Pack of 4  
Ht 8

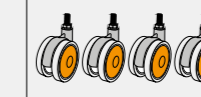

## Vertical flex-ducting

Ht 67,5  
Dpt 3,5  
W 10,8

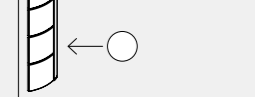

## Hanging PC holder

Ht 56,3  
Dpt 36  
W 28,7



## Adjustable hanging PC holder

Ht 58  
Dpt 26,5  
W 16÷22



## PC holder with castor wheels

Ht 39  
Dpt 50  
W 29



## HIP

Melamine-coated.  
Ht 29,4  
Dpt 25  
W 18

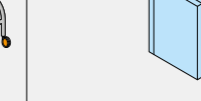

## HOP

Melamine-coated.  
Ht 29,4  
Dpt 25  
W 30



<b>Code</b>	<b>P38.99L</b>	<b>PL31.38S</b>	<b>P04.38K</b>	<b>P01.39E</b>	<b>P01.40L</b>
-------------	----------------	-----------------	----------------	----------------	----------------

## ABS cable hole

Ø 8

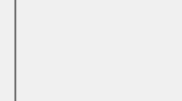

## Metal cable hole

Ø 8

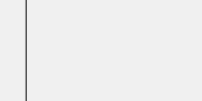

## Wireless charging

Ø 8



## Dual USB socket

Ø 3,7



## Cable grommet

Colour Black  
Channel 25,8 x 7,2 cm  
Ht 1,2  
Dpt 7,9  
W 26,4

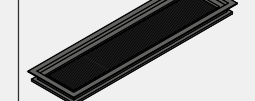

<b>Code</b>	<b>P37.79Y</b>	<b>PK72.89R</b>	<b>P08.34A</b>	<b>P08.35F</b>	<b>PL48.79D</b>
-------------	----------------	-----------------	----------------	----------------	-----------------

## Pocket for HEY leg

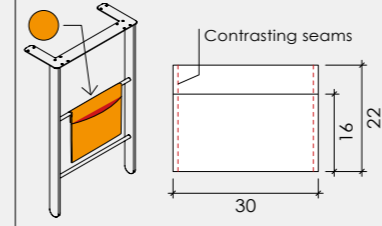

<b>Code</b>	<b>PK47.00A</b>				
-------------	-----------------	--	--	--	--

<sup>1</sup> Wireless charging:  
**Qi wireless charging standard**

<sup>2</sup> Dual USB socket:  
**Output: 5V DC - 2,10A Max. (1 x 2,10A) (2 x 1,05A)**

**OPTIONAL:** **A** - Extra colors for Side panels Writing-desk block and Drawer units  
**p. 409** **B** - Drawers and big drawers with soft-close

**CLUB**  
drawers and big drawers  
CHARM with soft-close "Quadro"  
type slides as standard  
(without surcharges)

GROUP 1 colors	Rovere Dorian <b>RD5T</b>	Rovere white <b>RW3Q</b>	Noce naturale <b>NN7H</b>	Eucalipto <b>CL1X</b>	Domy <b>DM7P</b>	Bianco UV <b>BU3Q</b>
	Ciliegio bianco <b>CB6K</b>	Malta <b>ML7H</b>	Feltro <b>FL8X</b>	Cemento Masdar <b>CM3Q</b>	Blu indaco <b>BI4B</b>	
	Noce <b>NC4B</b>	Desert <b>DS9L</b>	Canapa <b>CN1X</b>	Moka <b>MK6B</b>	Cipria <b>CP4J</b>	
	Bianco opaco <b>BI7A</b>	Grigio Dorian <b>GL4R</b>	Basalto <b>BS5T</b>	Grigio titanio <b>GZ8T</b>	Rosa bubble <b>RB7Y</b>	
	Agave <b>GV7A</b>	Verde Alpi <b>VA5T</b>	Cadaques <b>CQ3Q</b>	Giallo zafferano <b>GZ8A</b>		
	Blu opale <b>BO7H</b>			Corallo <b>CR5T</b>		

Types and colors FRONT	ONE	<table border="1"> <tr> <td>Rovere white <b>RW3Q</b></td> <td>Rovere Dorian <b>RD5T</b></td> <td>Ciliegio bianco <b>CB6K</b></td> <td>Noce naturale <b>NN7H</b></td> <td>Noce <b>NC4B</b></td> <td>Eucalipto <b>CL1X</b></td> <td>Malta <b>ML7H</b></td> </tr> <tr> <td>Feltro <b>FL8X</b></td> <td>Cemento Masdar <b>CM3Q</b></td> <td>Bianco opaco <b>BI7A</b></td> <td>Desert <b>DS9L</b></td> <td>Canapa <b>CN1X</b></td> <td>Moka <b>MK6B</b></td> <td>Grigio Dorian <b>GL4R</b></td> </tr> <tr> <td>Basalto <b>BS5T</b></td> <td>Grigio titanio <b>GZ8T</b></td> <td>Domy <b>DM7P</b></td> <td>Agave <b>GV7A</b></td> <td>Verde Alpi <b>VA5T</b></td> <td>Cadaques <b>CQ3Q</b></td> <td>Blu indaco <b>BI4B</b></td> </tr> <tr> <td>Blu opale <b>BO7H</b></td> <td>Cipria <b>CP4J</b></td> <td>Rosa bubble <b>RB7Y</b></td> <td>Giallo zafferano <b>GZ8A</b></td> <td>Corallo <b>CR5T</b></td> <td></td> <td></td> </tr> </table>							Rovere white <b>RW3Q</b>	Rovere Dorian <b>RD5T</b>	Ciliegio bianco <b>CB6K</b>	Noce naturale <b>NN7H</b>	Noce <b>NC4B</b>	Eucalipto <b>CL1X</b>	Malta <b>ML7H</b>	Feltro <b>FL8X</b>	Cemento Masdar <b>CM3Q</b>	Bianco opaco <b>BI7A</b>	Desert <b>DS9L</b>	Canapa <b>CN1X</b>	Moka <b>MK6B</b>	Grigio Dorian <b>GL4R</b>	Basalto <b>BS5T</b>	Grigio titanio <b>GZ8T</b>	Domy <b>DM7P</b>	Agave <b>GV7A</b>	Verde Alpi <b>VA5T</b>	Cadaques <b>CQ3Q</b>	Blu indaco <b>BI4B</b>	Blu opale <b>BO7H</b>	Cipria <b>CP4J</b>	Rosa bubble <b>RB7Y</b>	Giallo zafferano <b>GZ8A</b>	Corallo <b>CR5T</b>		
		Rovere white <b>RW3Q</b>	Rovere Dorian <b>RD5T</b>	Ciliegio bianco <b>CB6K</b>	Noce naturale <b>NN7H</b>	Noce <b>NC4B</b>	Eucalipto <b>CL1X</b>	Malta <b>ML7H</b>																												
Feltro <b>FL8X</b>	Cemento Masdar <b>CM3Q</b>	Bianco opaco <b>BI7A</b>	Desert <b>DS9L</b>	Canapa <b>CN1X</b>	Moka <b>MK6B</b>	Grigio Dorian <b>GL4R</b>																														
Basalto <b>BS5T</b>	Grigio titanio <b>GZ8T</b>	Domy <b>DM7P</b>	Agave <b>GV7A</b>	Verde Alpi <b>VA5T</b>	Cadaques <b>CQ3Q</b>	Blu indaco <b>BI4B</b>																														
Blu opale <b>BO7H</b>	Cipria <b>CP4J</b>	Rosa bubble <b>RB7Y</b>	Giallo zafferano <b>GZ8A</b>	Corallo <b>CR5T</b>																																
matte																																				
glossy																																				
		<table border="1"> <tr> <td>Rovere white <b>RW3Q</b></td> <td>Rovere Dorian <b>RD5T</b></td> <td>Ciliegio bianco <b>CB6K</b></td> <td>Noce naturale <b>NN7H</b></td> <td>Noce <b>NC4B</b></td> <td>Eucalipto <b>CL1X</b></td> <td>Malta <b>ML7H</b></td> </tr> <tr> <td>Feltro <b>FL8X</b></td> <td>Cemento Masdar <b>CM3Q</b></td> <td>Bianco opaco <b>BI7A</b></td> <td>Desert <b>DS9L</b></td> <td>Canapa <b>CN1X</b></td> <td>Moka <b>MK6B</b></td> <td>Grigio Dorian <b>GL4R</b></td> </tr> <tr> <td>Basalto <b>BS5T</b></td> <td>Grigio titanio <b>GZ8T</b></td> <td>Domy <b>DM7P</b></td> <td>Agave <b>GV7A</b></td> <td>Verde Alpi <b>VA5T</b></td> <td>Cadaques <b>CQ3Q</b></td> <td>Blu indaco <b>BI4B</b></td> </tr> <tr> <td>Blu opale <b>BO7H</b></td> <td>Cipria <b>CP4J</b></td> <td>Rosa bubble <b>RB7Y</b></td> <td>Giallo zafferano <b>GZ8A</b></td> <td>Corallo <b>CR5T</b></td> <td></td> <td></td> </tr> </table>							Rovere white <b>RW3Q</b>	Rovere Dorian <b>RD5T</b>	Ciliegio bianco <b>CB6K</b>	Noce naturale <b>NN7H</b>	Noce <b>NC4B</b>	Eucalipto <b>CL1X</b>	Malta <b>ML7H</b>	Feltro <b>FL8X</b>	Cemento Masdar <b>CM3Q</b>	Bianco opaco <b>BI7A</b>	Desert <b>DS9L</b>	Canapa <b>CN1X</b>	Moka <b>MK6B</b>	Grigio Dorian <b>GL4R</b>	Basalto <b>BS5T</b>	Grigio titanio <b>GZ8T</b>	Domy <b>DM7P</b>	Agave <b>GV7A</b>	Verde Alpi <b>VA5T</b>	Cadaques <b>CQ3Q</b>	Blu indaco <b>BI4B</b>	Blu opale <b>BO7H</b>	Cipria <b>CP4J</b>	Rosa bubble <b>RB7Y</b>	Giallo zafferano <b>GZ8A</b>	Corallo <b>CR5T</b>		
Rovere white <b>RW3Q</b>	Rovere Dorian <b>RD5T</b>	Ciliegio bianco <b>CB6K</b>	Noce naturale <b>NN7H</b>	Noce <b>NC4B</b>	Eucalipto <b>CL1X</b>	Malta <b>ML7H</b>																														
Feltro <b>FL8X</b>	Cemento Masdar <b>CM3Q</b>	Bianco opaco <b>BI7A</b>	Desert <b>DS9L</b>	Canapa <b>CN1X</b>	Moka <b>MK6B</b>	Grigio Dorian <b>GL4R</b>																														
Basalto <b>BS5T</b>	Grigio titanio <b>GZ8T</b>	Domy <b>DM7P</b>	Agave <b>GV7A</b>	Verde Alpi <b>VA5T</b>	Cadaques <b>CQ3Q</b>	Blu indaco <b>BI4B</b>																														
Blu opale <b>BO7H</b>	Cipria <b>CP4J</b>	Rosa bubble <b>RB7Y</b>	Giallo zafferano <b>GZ8A</b>	Corallo <b>CR5T</b>																																
		<p>Specify the color of the CLUB handle</p> <table border="1"> <tr> <td>Bianco opaco <b>BI7A</b></td> <td>Desert <b>DS9L</b></td> <td>Canapa <b>CN1X</b></td> <td>Moka <b>MK6B</b></td> <td>Grigio Dorian <b>GL4R</b></td> <td>Basalto <b>BS5T</b></td> <td>Grigio titanio <b>GZ8T</b></td> </tr> <tr> <td>Domy <b>DM7P</b></td> <td>Agave <b>GV7A</b></td> <td>Verde Alpi <b>VA5T</b></td> <td>Cadaques <b>CQ3Q</b></td> <td>Blu indaco <b>BI4B</b></td> <td>Blu opale <b>BO7H</b></td> <td>Cipria <b>CP4J</b></td> </tr> <tr> <td>Rosa bubble <b>RB7Y</b></td> <td>Giallo zafferano <b>GZ8A</b></td> <td>Corallo <b>CR5T</b></td> <td></td> <td></td> <td></td> <td></td> </tr> </table>							Bianco opaco <b>BI7A</b>	Desert <b>DS9L</b>	Canapa <b>CN1X</b>	Moka <b>MK6B</b>	Grigio Dorian <b>GL4R</b>	Basalto <b>BS5T</b>	Grigio titanio <b>GZ8T</b>	Domy <b>DM7P</b>	Agave <b>GV7A</b>	Verde Alpi <b>VA5T</b>	Cadaques <b>CQ3Q</b>	Blu indaco <b>BI4B</b>	Blu opale <b>BO7H</b>	Cipria <b>CP4J</b>	Rosa bubble <b>RB7Y</b>	Giallo zafferano <b>GZ8A</b>	Corallo <b>CR5T</b>											
Bianco opaco <b>BI7A</b>	Desert <b>DS9L</b>	Canapa <b>CN1X</b>	Moka <b>MK6B</b>	Grigio Dorian <b>GL4R</b>	Basalto <b>BS5T</b>	Grigio titanio <b>GZ8T</b>																														
Domy <b>DM7P</b>	Agave <b>GV7A</b>	Verde Alpi <b>VA5T</b>	Cadaques <b>CQ3Q</b>	Blu indaco <b>BI4B</b>	Blu opale <b>BO7H</b>	Cipria <b>CP4J</b>																														
Rosa bubble <b>RB7Y</b>	Giallo zafferano <b>GZ8A</b>	Corallo <b>CR5T</b>																																		
		<table border="1"> <tr> <td>Trasparente <b>TR9M</b></td> <td>Trasparente fumé <b>FT8P</b></td> <td>Stop-sol <b>ST6P</b></td> <td>Specchio <b>SP7L</b></td> <td></td> <td></td> <td></td> </tr> </table>							Trasparente <b>TR9M</b>	Trasparente fumé <b>FT8P</b>	Stop-sol <b>ST6P</b>	Specchio <b>SP7L</b>																								
Trasparente <b>TR9M</b>	Trasparente fumé <b>FT8P</b>	Stop-sol <b>ST6P</b>	Specchio <b>SP7L</b>																																	
		<p>Specify the color of the aluminum frame</p> <table border="1"> <tr> <td>Alluminio <b>AL1A</b></td> <td>Titan grey <b>TG7H</b></td> <td></td> <td></td> <td></td> <td></td> <td></td> </tr> </table>							Alluminio <b>AL1A</b>	Titan grey <b>TG7H</b>																										
Alluminio <b>AL1A</b>	Titan grey <b>TG7H</b>																																			

Shelves, Cubes and Boiserie

Shelves Th 2.5	454
Shelves in frosted silk-screened glass Th 1	456
PODIO shelves Dpt 24 - Th 5.5	456
Shelf holders and accessories	457
CUBOLOTTTO	458
TEMA	458
SCHEMA	459
MODO	459
JOINT	460
ALBATROS	460
PARALLEL	461
CLIO	461
JIB	462
ORIZZONTE	462
PEPITA boiserie system	464
DARSENА boiserie system	470



# Shelves Th 2.5

## Shelves Dpt 26

	45	60	90	120	135	180	210	225	270	Custom-made Max 360 Min 30
<b>Code</b> Without shelf holder	P39.11L	P39.12R	P39.13W	P39.14B	P39.15G	P39.16N	P78.95X	P39.18Y	P39.19D	PL38.73M
<b>Code</b> With shelf holders	PK61.00F <sup>2</sup>	PK61.01N <sup>2</sup>	PK61.02U <sup>2</sup>	PK61.03A <sup>2</sup>	PK61.04G <sup>2</sup>	PK61.05P <sup>2</sup>	PK61.10M <sup>4</sup>	PK61.11T <sup>4</sup>	PK61.12Z <sup>4</sup>	PK61.13F <sup>2</sup>
INTEGRATED	<input type="checkbox"/>	<input type="checkbox"/>	<input type="checkbox"/>	<input type="checkbox"/>	<input type="checkbox"/>	<input type="checkbox"/>	<input type="checkbox"/>	<input type="checkbox"/>	<input type="checkbox"/>	<input type="checkbox"/>
LENA	<input type="checkbox"/>	<input type="checkbox"/>	<input type="checkbox"/>	<input type="checkbox"/>	<input type="checkbox"/>	<input type="checkbox"/>	<input type="checkbox"/>	<input type="checkbox"/>	<input type="checkbox"/>	<input type="checkbox"/>
GOLIA	<input type="checkbox"/>	<input type="checkbox"/>	<input type="checkbox"/>	<input type="checkbox"/>	<input type="checkbox"/>	<input type="checkbox"/>	<input type="checkbox"/>	<input type="checkbox"/>	<input type="checkbox"/>	<input type="checkbox"/>
SCACCO	<input type="checkbox"/>	<input type="checkbox"/>	<input type="checkbox"/>	<input type="checkbox"/>	<input type="checkbox"/>	<input type="checkbox"/>	<input type="checkbox"/>	<input type="checkbox"/>	<input type="checkbox"/>	<input type="checkbox"/>

For shelves above **W 180** in size, 2 additional shelf holders are supplied.

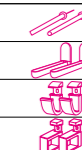

## Corner shelf Dpt 26

	R corner counter-shelf Custom-made Max 360 Min 30	R corner shelf Custom-made Max 360 Min 30	L corner shelf Custom-made Max 360 Min 30	L corner counter-shelf Custom-made Max 360 Min 30
<b>Code</b> Without shelf holder	PL38.65U	PL38.66A	PL38.67G	PL38.68P
<b>Code</b> With shelf holders	PK61.06V <sup>2</sup>	PK61.07B <sup>2</sup>	PK61.08H <sup>2</sup>	PK61.09Q <sup>2</sup>
LENA	<input type="checkbox"/>	<input type="checkbox"/>	<input type="checkbox"/>	<input type="checkbox"/>
GOLIA	<input type="checkbox"/>	<input type="checkbox"/>	<input type="checkbox"/>	<input type="checkbox"/>
SCACCO	<input type="checkbox"/>	<input type="checkbox"/>	<input type="checkbox"/>	<input type="checkbox"/>

For shelves above **W 180** in size, 2 additional shelf holders are supplied.

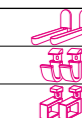

### Corner shelves

Specify the size of the corner of the wall on both sides.

- The dimensions in the diagrams (A) only apply if shelf holders are NOT used.
- The dimensions in the diagrams (B) only apply if LENA, GOLIA and SCACCO shelf holders are used.

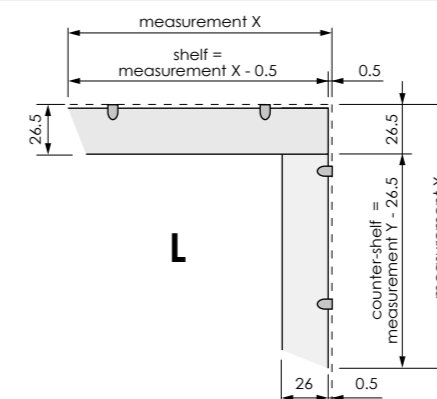
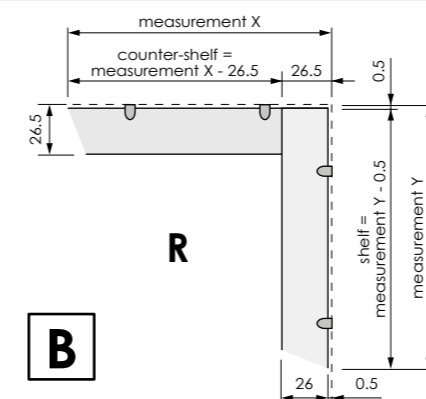
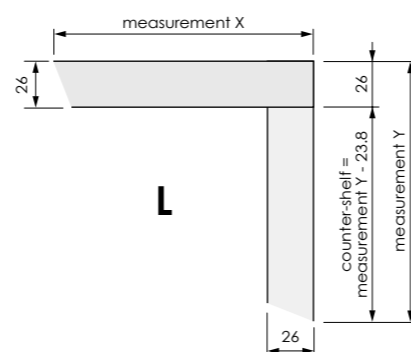
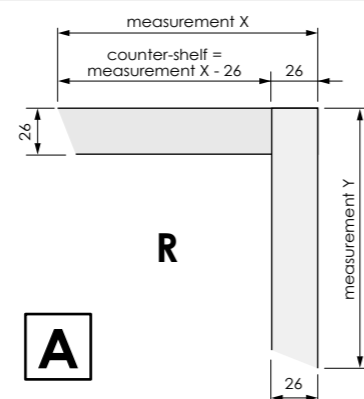

## OMEGA shelves Dpt 31.7

	60	90	120	135
<b>Code</b> With shelf holders	P10.96P <sup>2</sup>	P10.97U <sup>2</sup>	P10.98Z <sup>2</sup>	P10.99E <sup>2</sup>
GOLIA	<input type="checkbox"/>	<input type="checkbox"/>	<input type="checkbox"/>	<input type="checkbox"/>
SCACCO	<input type="checkbox"/>	<input type="checkbox"/>	<input type="checkbox"/>	<input type="checkbox"/>

## Shelves REINFORCED 1 Dpt 28.5 - Ht 26

	45	60	90	120	135	180	210	225	270	Custom-made Max 360 Min 40
<b>Code</b>	P40.50V	P40.53M	P40.54S	P40.57H	P40.60Z	P40.66G	P94.19A	P40.78X	P40.80H	P40.82U

## Shelves REINFORCED 2 Dpt 28.5 - Ht 26

	45	60	90	120	135	180	210	225	270	Custom-made Max 360 Min 40
<b>Code</b>	P63.70T	P64.88U	P64.89Z	P65.57D	P65.58K	P65.59Q	P94.20F	P65.61A	P65.62F	P65.63M

- Components in **GROUP 2 colors**
- Complete with hardware for fixing to wall.
- Complete with hardware for fixing to panel  
In case of wall fixing the choice of hardware depends on the wall conditions and should be made by the assembler.
- Shaped components available with contrasting edging.
- B17A AL1A
- Indicates the number of shelf holders supplied.

**NOTE:** When ordering specify the type of shelf holder.  
**Maximum recommended load (net of shelves):**  
**18 kg** for each pair of LENA shelf holders.  
**30 kg** for each pair of INTEGRATED, GOLIA and SCACCO shelf holders.  
**1 kg** every 5 linear cm for shelves REINFORCED.  
 N.B. for loads evenly distributed over the shelf. The distance between two shelf holders must not exceed 80 cm.



# Shelves in frosted silk-screened glass Th 1

# Shelf holders and accessories

	Dpt 26		Dpt 20			
	90	135	80	125		
<b>Code</b> With shelf holders	<b>P40.43G 2</b>	<b>P40.45T 2</b>	<b>P40.48K 2</b>	<b>P40.49Q 2</b>		
INCH						
GOLIA						
SCACCO						

# PODIO shelves Dpt 24 - Th 5.5

- With shelf holders INTEGRATED.
- Element can not be modified.

	90	120	150		
<b>Code</b>	<b>PL38.75Z 2</b>	<b>PL38.76F 3</b>	<b>PL38.77N 3</b>		

Pairs of shelf holders	INCH	LENA	GOLIA	SCACCO	INTEGRATED
	W 2,4 Dpt 5,7 <i>For shelves in frosted silk-screened glass only</i>	Ht 8 Dpt 17	W 4 Dpt 8,6	W 3,5 Dpt 10	
<b>Code</b>	<b>P40.96V</b>	<b>PK61.14N</b>	<b>P40.52F</b>	<b>P71.68C</b>	<b>P40.75F</b>

Metallic bookends	
	W 10 Dpt 13,5
<b>Code</b>	<b>P39.05C</b>

Lighting	LED spotlights Ø 6.5	Wireless switch	LED lamp SPARK	LED lamp SKY
	12 volt 1.7 watt. <b>+ 50,00 for power pack.</b>	For LED spotlights Ø 6.5	Manual switch or light sensor that can be operated with the side switch. Can be applied with the provided screws or with biadhesive Velcro. 3 - 1.5v AAA batteries not included.	Built-in touch switch. Can be applied with the provided screws or with biadhesive tape. 3 - 1.5v AAA batteries not included.
<b>Code</b>	<b>PL86.17N</b>	<b>PL86.18U</b>	<b>P07.30A</b>	<b>P07.31F</b>

Stickers	CIRCLE	GRID	BALLOONS
The images are for the sole purpose of illustrating the product. It will be up to the customer to use the Stickers to their liking.			
	Ø 110	120 x 120	W 30
<b>Code</b>	<b>PK60.00B</b>	<b>PK60.02Q</b>	<b>PK60.03W*</b>

## \* LED SPOT LIGHT Ø 6,5

The colour tone of the LED strip is natural. We provide a power pack (with a surcharge) able to support from 1 to 6 spotlights. Spot lights are assembled with wiring in sight. The on/off switching of the shelves can be done in 2 different ways: By connecting the power supply unit to your home electrical system and using your own standard power switch; By ordering our wireless on/off switch from catalogue.

The minimum length of a shelf with LED spotlights is 60. Two holes are made for the spotlights. For longer shelves which require more spotlights, please specify the total number of spotlights. They must be spaced at equal distances except for the ones on the sides where the centre hole is positioned 15 cm from the edge (see diagram).

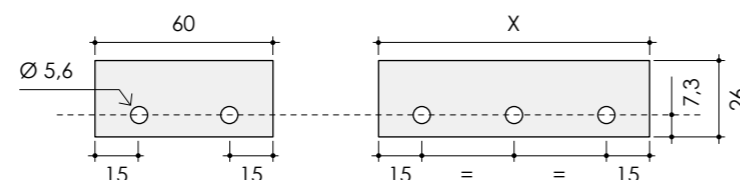

**+ 50,00 for power pack.**

**NOTE:** When ordering specify the type of shelf holder.

**Maximum recommended load (net of shelves):**

**12 kg** for each pair of INCH shelf holders.

**18 kg** for each pair of LENA shelf holders.

**30 kg** for each pair of INTEGRATED, GOLIA and SCACCO shelf holders.

N.B. for loads evenly distributed over the shelf. The distance between two shelf holders must not exceed 80 cm.

Aluminium colour components

Complete with hardware for fixing to wall.

Complete with hardware for fixing to panel  
In case of wall fixing the choice of hardware depends on the wall conditions and should be made by the assembler.

RW3Q RD5T CB6K NN7H NC4B CL1X ML7H CM3Q DS9L CN1X MK6B GL4R BS5T GZ8T  
 B17A AL1A

Indicates the number of shelf holders supplied.

# CUBOLOTTO

Structure in board Th 1.8.  
**Equipped with hardware for mounting to wall or panel.**  
 Maximum recommended load 30 Kg.

CUBE colouring example:  
 Structure (Canapa - CN1X)

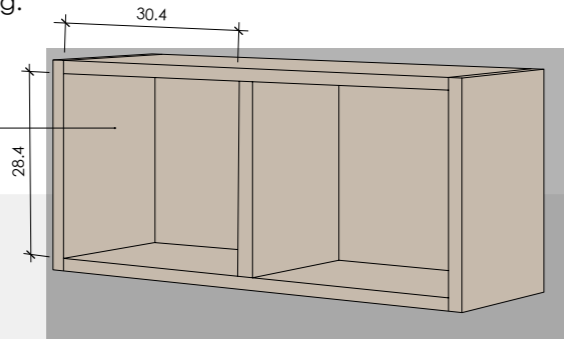

A composition can be created by combining several elements and turning them into different positions.

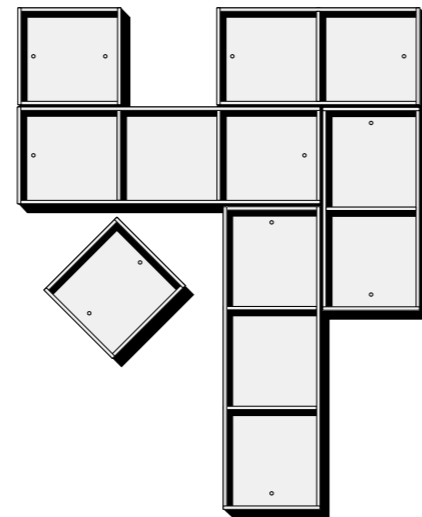

Open

Ht 32	34	66	98,1
Dpt 30,7			
Code	P74.91N	P74.92T	P35.98V

# SCHEMA

Structure in board Th 1.8.  
**Equipped with hardware for mounting to wall or panel.**  
 Maximum recommended load 15 Kg.

SCHEMA colouring example:

Rear panel (Agave - GV7A)

Structure (Canapa - CN1X)

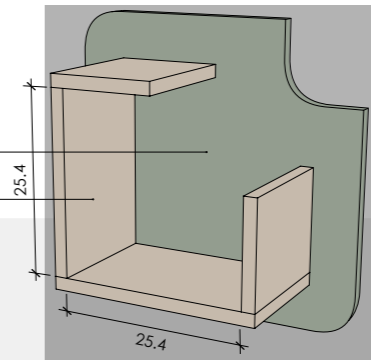

A composition can be created by combining several elements.

Turning the unit 90° anti-clockwise creates a mirror-image effect.

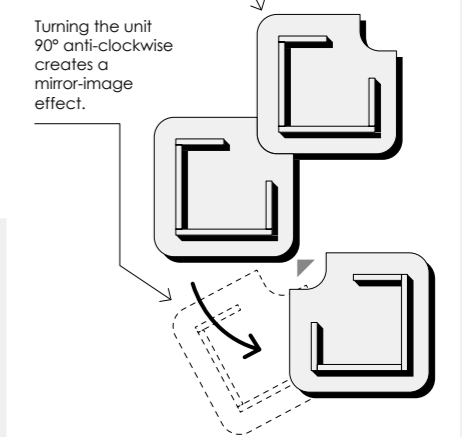

SCHEMA can be used to create compositions as shown below:

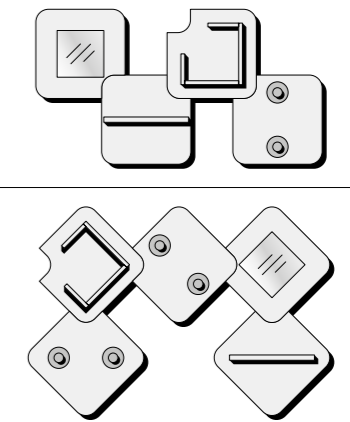

Ht 42  
 Dpt 19,8  
 W 42



With shelf  
 Dpt 18 - W 40



Possible solutions:

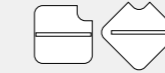

Code	P98.84S	P71.66S
------	---------	---------

Ht 42  
 W 42



With mirror  
 W 22 x 22  
 Dpt 1,8

With 2 BOLLINO clothes hooks  
 Dpt 5,8



BOLLINO is available in:  
 Bianco opaco (B17A)  
 Alluminio (AL1A)

Possible solutions:

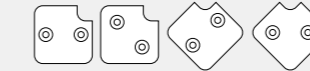

Code	P71.65M	P71.67X
------	---------	---------

# TEMA

Structure in board Th 1.8.  
**Equipped with hardware for mounting to wall or panel.**  
 Maximum recommended load 15 Kg.

TEMA colouring example:

Rear panel (Agave - GV7A)

Structure (Canapa - CN1X)

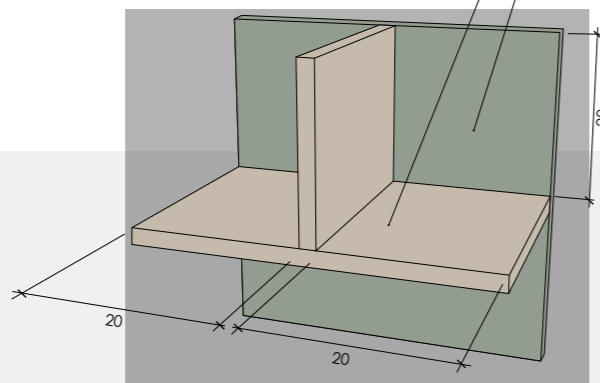

A composition can be created by combining several elements and turning them into different positions.

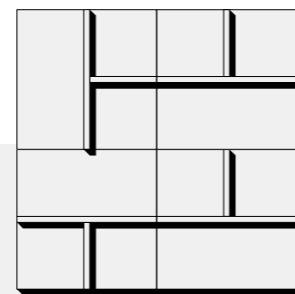

Ht 42  
 Dpt 19,8  
 W 42

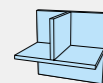

Code	P71.64F
------	---------

Components in GROUP 2 colors

# MODO

Structure in board Th 1.8.  
**Equipped with hardware for mounting to wall or panel.**  
 Maximum recommended load 15 Kg.

MODO colouring example:

Rear panel (Agave - GV7A)

Structure (Canapa - CN1X)

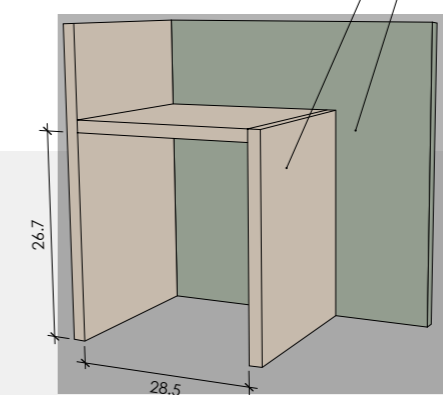

A composition can be created by combining several elements and turning them into different positions.

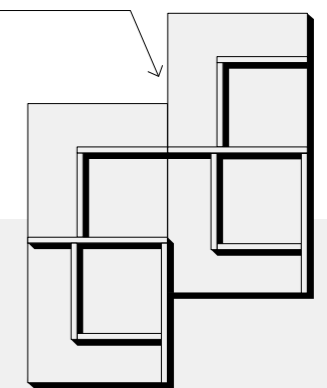

Ht 42  
 Dpt 19,8  
 W 42

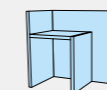

Code	P71.70P
------	---------

# JOINT

Structure in board Th 1.8.  
**Equipped with hardware for mounting to wall or panel.**  
 Maximum recommended load 15 Kg.

JOINT colouring example:  
 A composition can be created by combining several elements and turning them into different positions.

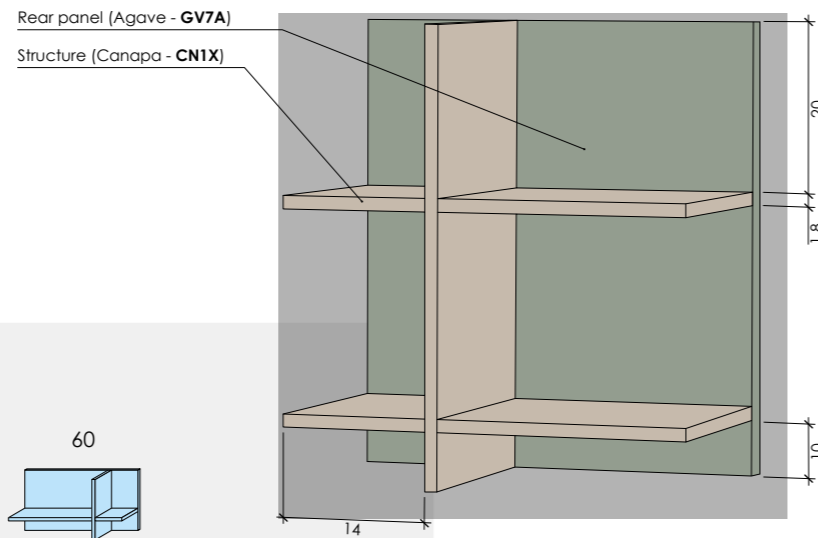

Ht 32 Dpt 19,8	30	45	60
Code	PL50.24N	PL50.25U	PL50.26A

Ht 64 Dpt 19,8	30	45	60
Code	PL50.27G	PL50.28P	PL50.29V

# ALBATROS

Structure in board Th 1.8.  
**Equipped with hardware for mounting to wall or panel.**  
 Maximum recommended load 15 Kg.

ALBATROS colouring example:  
 A composition can be created by combining several elements and turning them into different positions.

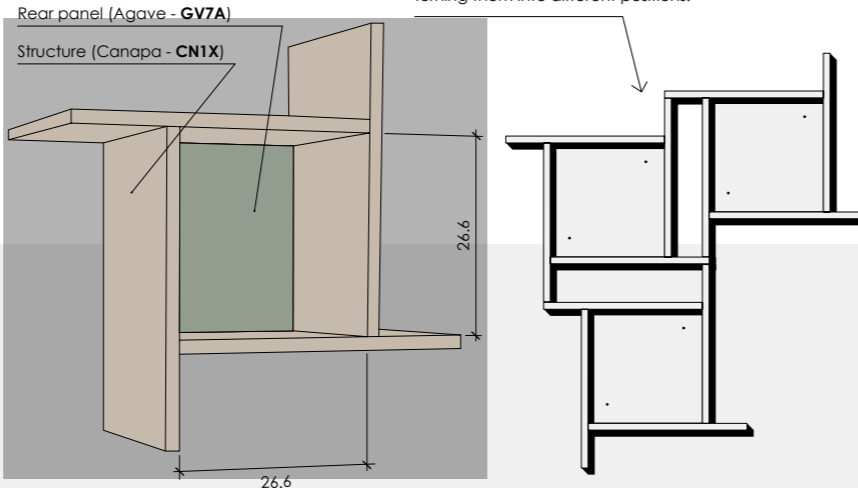

Ht 57,5 Dpt 18 W 57,5	
Code	PL50.08C

Components in GROUP 2 colors

# PARALLEL

Board structure Th 1.8.  
**Equipped with hardware for mounting to wall or panel and can be placed on desk tops and benches.**  
 Recommended maximum load 15 Kg.

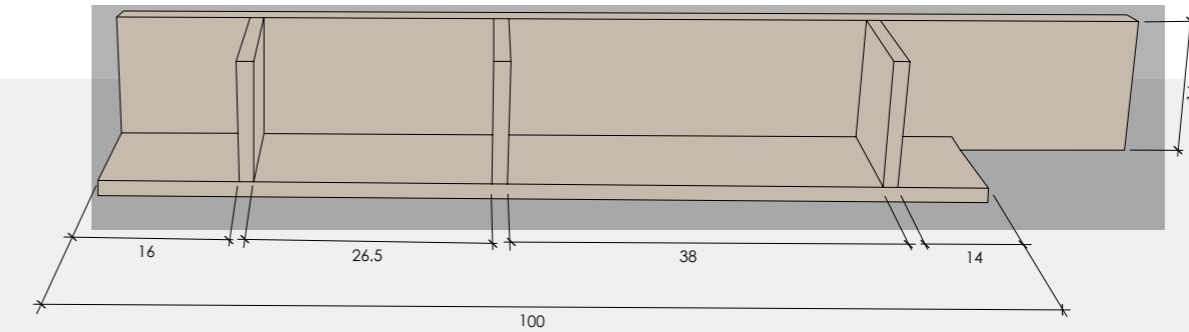

A composition can be created by combining several elements and turning them into different positions.

Ht 16,4 Dpt 19,8 W 120	
Code	PL50.09K

# CLIO

Structure in board Th 1.8.  
**Equipped with hardware for mounting to wall or panel.**  
 Maximum recommended load 15 Kg.

CLIO colouring example:  
 A composition can be created by combining several elements and turning them into different positions.

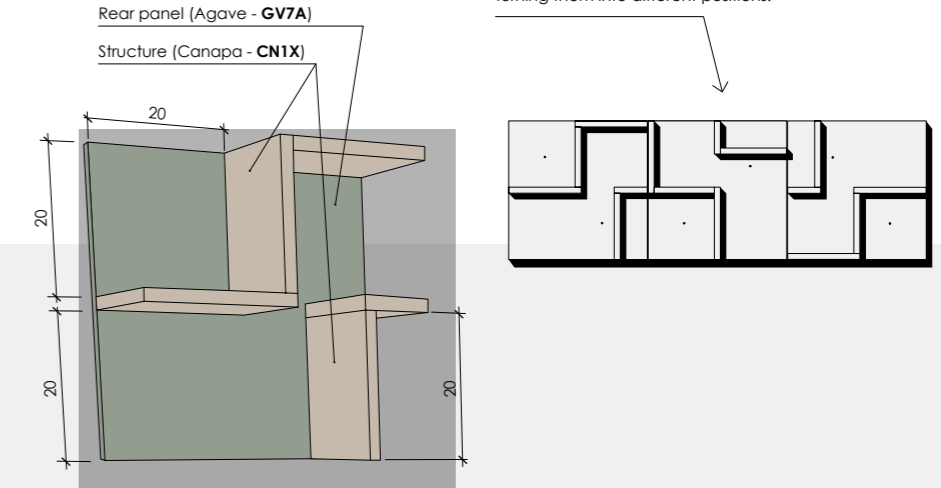

Ht 42 Dpt 19,8 W 42	
Code	PL50.10F

# JIB

Structure in board Th 1.8.  
Base in painted sheet metal Th 0.3  
(Grigio titanio - GZ8T).

**Equipped with hardware for mounting to wall or panel.**  
Maximum recommended load 15 Kg.

JIB colouring example:

Side panels (Canapa - CN1X)

Back panel (Agave - GV7A)

A composition can be created by combining several elements and turning them into different positions.

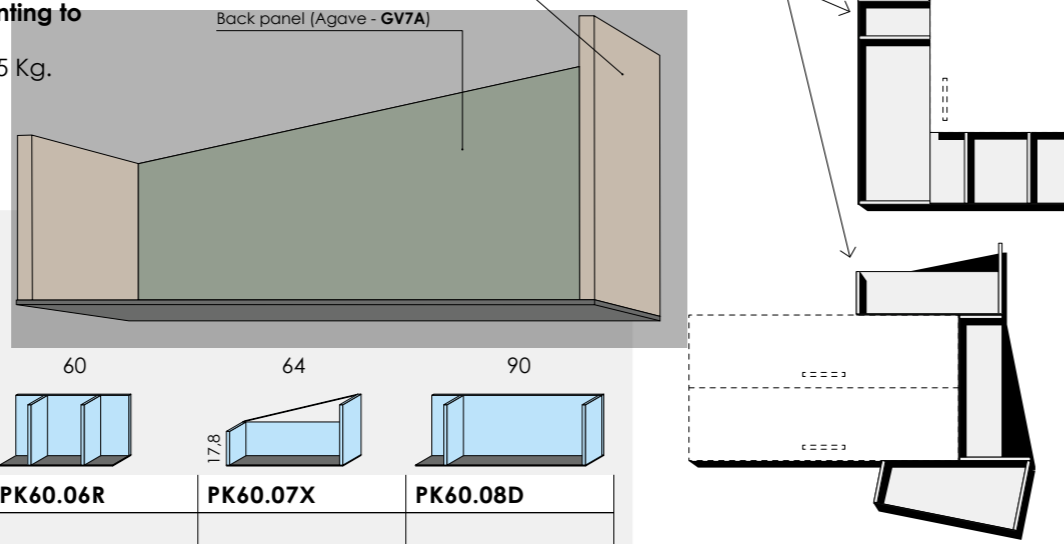

Ht 32	30	60	64	90
Dpt 30,7				
Code	PK60.05K	PK60.06R	PK60.07X	PK60.08D

# ORIZZONTE

Structure in board Th 1.8.

**Equipped with hardware for mounting to wall or panel.**  
Maximum recommended load 15 Kg.

ORIZZONTE colouring example:

Back panel (Agave - GV7A)

Structure (Canapa - CN1X)

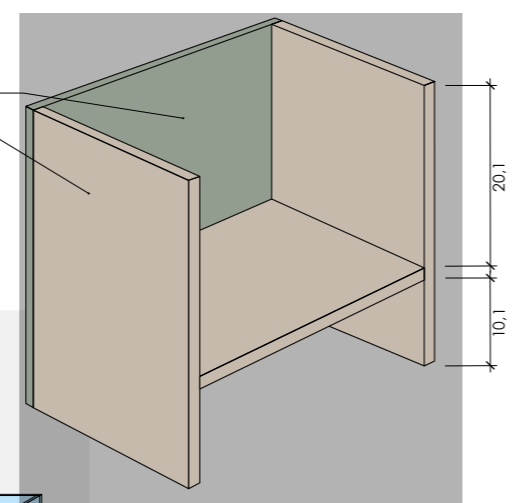

Ht 32	45	60	90	120
Dpt 30,7				
Code	PK60.80V	PK60.81B	PK60.82H	PK60.83Q

Components in GROUP 2 colors

# PEPITA boiserie system

These are panels that can be used to create panelling compositions by combining multiple elements. Available in smooth version, with slats or with cubes.

The smooth panels Th 1.8 protrude from the wall by 2.6 cm after installation.

The slats H 3 are in solid natural ash wood.

The cubes in panel Th 1.8 can be in a different colour with respect to the smooth supporting panels.

**Hardware for wall mounting supplied.**

**Maximum recommended load:**  
10 kg for each cube.

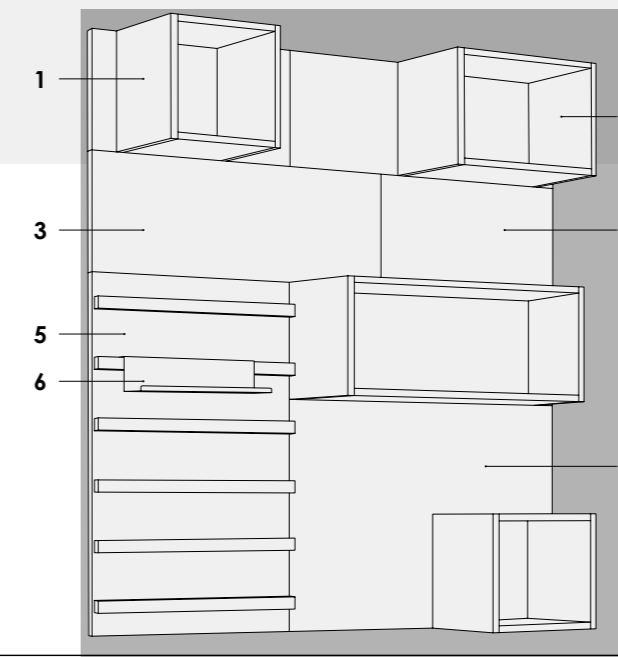
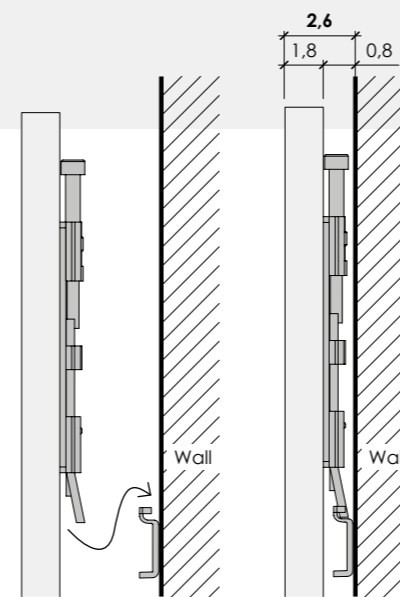
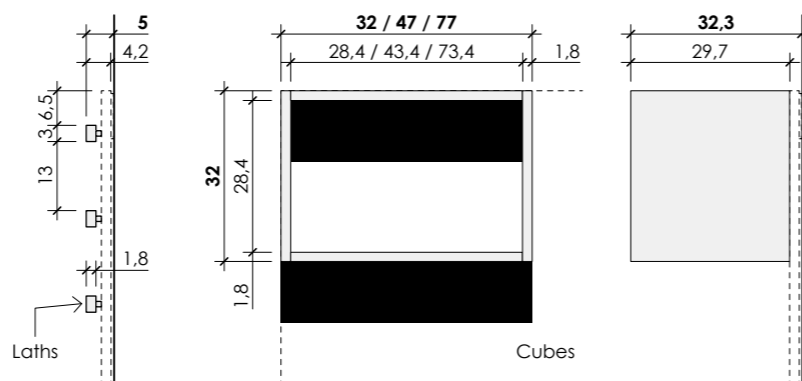

Example of a composition PEPITA:

- 1 Left panel W 60 with cube
- 2 Right panel W 90 with cube
- 3 Smooth panel W 90
- 4 Smooth panel W 60
- 5 Panel with laths W 60
- 6 Tray
- 7 Left panel W 90 with cubes

## Smooth panels

Ht 32  
Dpt 2,6

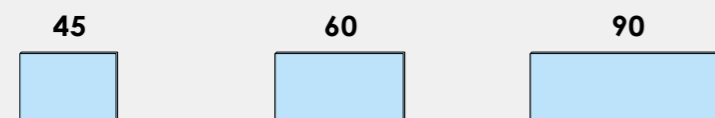

Code	PK60.09L	PK60.10G	PK60.11P		
------	----------	----------	----------	--	--

Ht 64  
Dpt 2,6

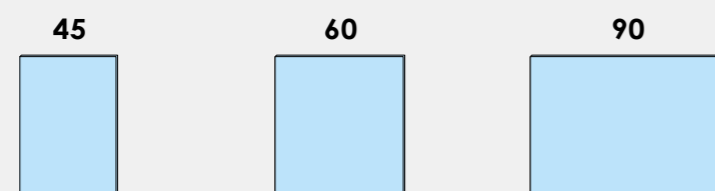

Code	PK60.12V	PK60.13B	PK60.14H		
------	----------	----------	----------	--	--

Ht 96  
Dpt 2,6

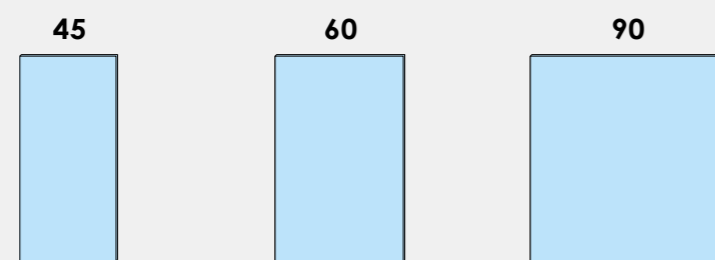

Code	PK60.15Q	PK60.16W	PK60.17C		
------	----------	----------	----------	--	--

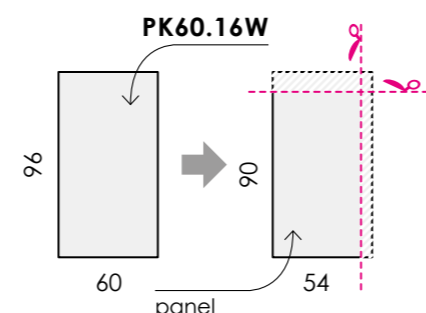

**Cutting of panels to custom sizes.**  
The upper measure panel is used by applying the surcharge.

## Panels with laths

Ht 64  
Dpt 5

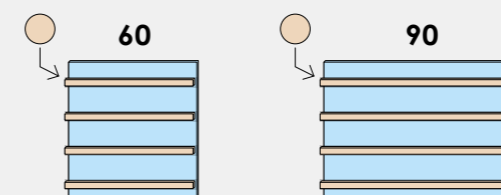

Code	PK60.19R	PK60.20N			
------	----------	----------	--	--	--

Ht 96  
Dpt 5

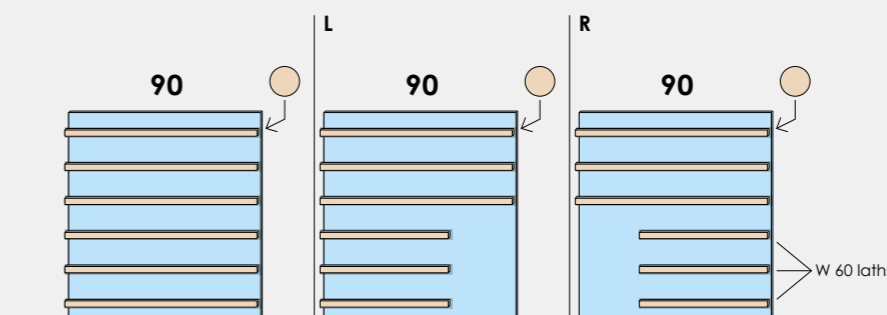

Code	PK60.21U	PK60.22A	PK60.23G		
------	----------	----------	----------	--	--

**Trays in folded and painted sheet metal**  
Th 2 mm

Colors:  
B17A GZ8A GV7A

Ht 8,5  
Dpt 12,2

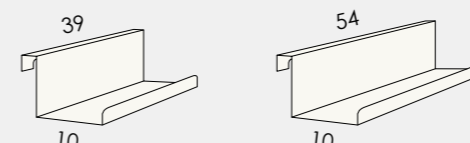

Code	PK60.24P	PK60.25V			
------	----------	----------	--	--	--

Components in GROUP 2

Solid natural ash wood

Wood is a natural product and as such is subject to variations in color and grain. Differences in grain or color therefore do not constitute grounds for dispute.

# PEPITA boiserie system

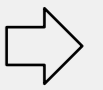

## Panels with cubes

### L

Ht 32  
Dpt 32,3

Code	PK60.26B	PK60.27H	PK60.28Q	PK60.29W	PK60.30T
------	----------	----------	----------	----------	----------

Ht 64  
Dpt 32,3

Code	PK60.31Z	PK60.32F	PK60.33N	PK60.34U	PK60.35A
------	----------	----------	----------	----------	----------

Ht 96  
Dpt 32,3

Code	PK60.36G	PK60.37P	PK60.38V	PK60.39B	PK60.40Y
------	----------	----------	----------	----------	----------

Ht 96  
Dpt 32,3

Code	PK60.41E	PK60.42M	PK60.43T	PK60.44Z	PK60.45F
------	----------	----------	----------	----------	----------

Components in GROUP 2 colors

## Panels with cubes

### R

Ht 32  
Dpt 32,3

Code	PK60.46N	PK60.47U	PK60.48A	PK60.49G	PK60.50D
	140,00				

Ht 64  
Dpt 32,3

Code	PK60.51L	PK60.52S	PK60.53Y	PK60.54E	PK60.55M
------	----------	----------	----------	----------	----------

Ht 96  
Dpt 32,3

Code	PK60.56T	PK60.57Z	PK60.58F	PK60.59N	PK60.60K
------	----------	----------	----------	----------	----------

Ht 96  
Dpt 32,3

Code	PK60.61R	PK60.62X	PK60.63D	PK60.64L	PK60.65S
------	----------	----------	----------	----------	----------

Maximum recommended load:  
10 kg for each cube.



# PEPITA boiserie system

## Compositions

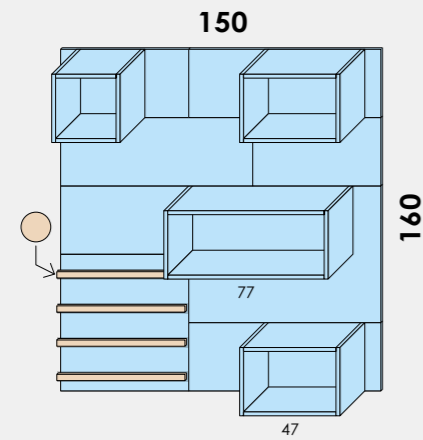

Code PK60.70Q

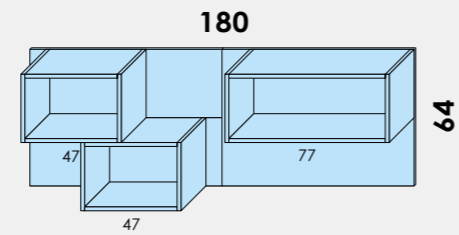

Code PK60.71W

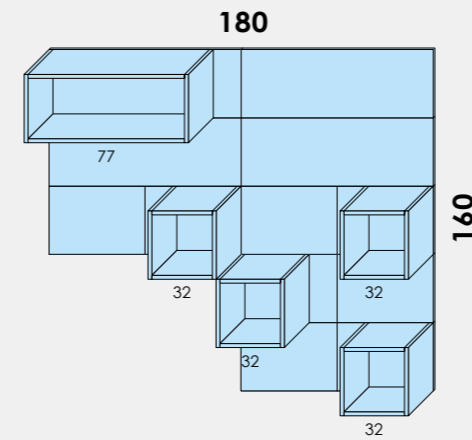

Code PK60.75X

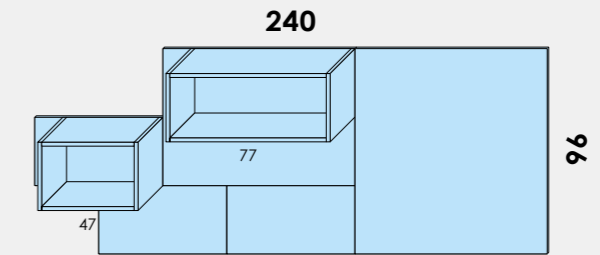

Code PK60.76D

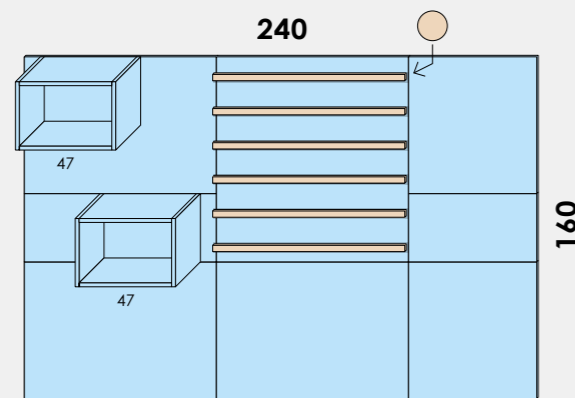

Code PK60.77L

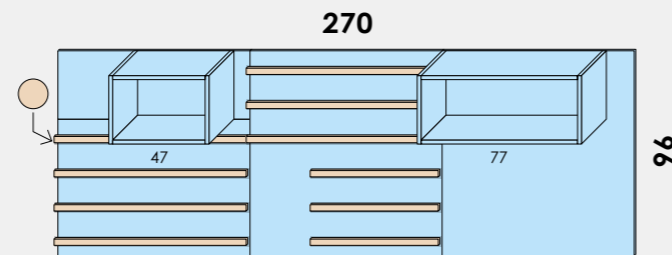

Code PK60.72C

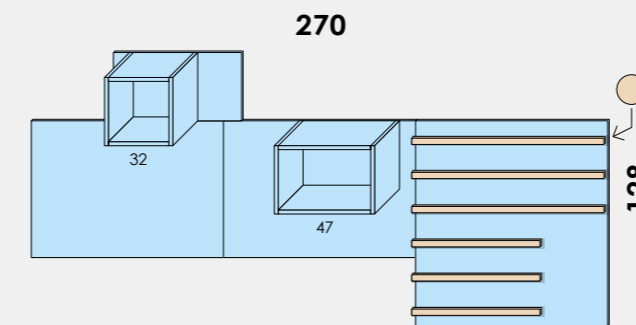

Code PK60.73K

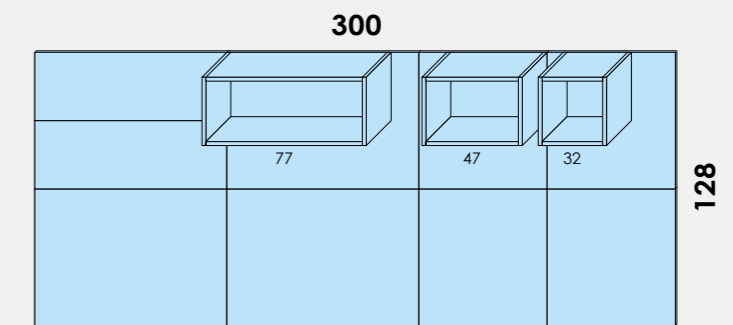

Code PK60.78S

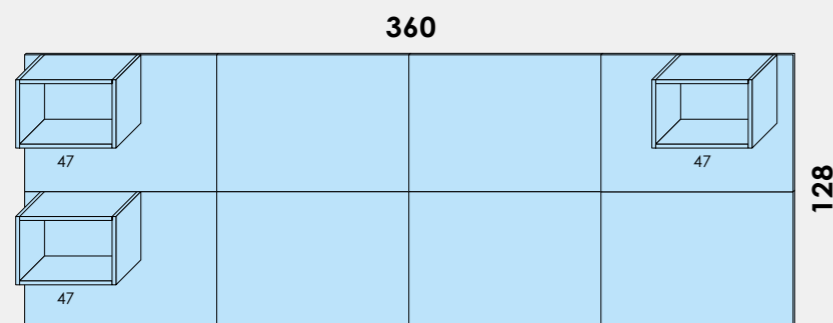

Code PK60.74R

■ Components in **GROUP 2 colors**  
● **Solid natural ash wood**  
 Wood is a natural product and as such is subject to variations in color and grain. Differences in grain or color therefore do not constitute grounds for dispute.

**Maximum recommended load:**  
**10 kg for each cube.**

# DARSENA boiserie system

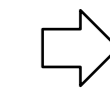

## When placing the order:

- We recommend using our graphic software.
- A graphical representation and/or drawing of the complete composition must be provided.
- Inner panels Th 1.8 must always be combined with outer panels Th 2.5.
- The outer TV panel, if not used singularly, can only be placed alongside outer panels Th 2.5.
- The outer panels Th 2.5 + Th 1.8 (start/end) H 129.4/129.8 must be positioned at the start or end of the composition in combination with suspended base units complete with top Th 1.4 or 1.8.
- It is not possible to place 2 or more panels with shelves side by side (either inner or outer).
- Panelling elements have a clearance of 0.8 cm from the wall.

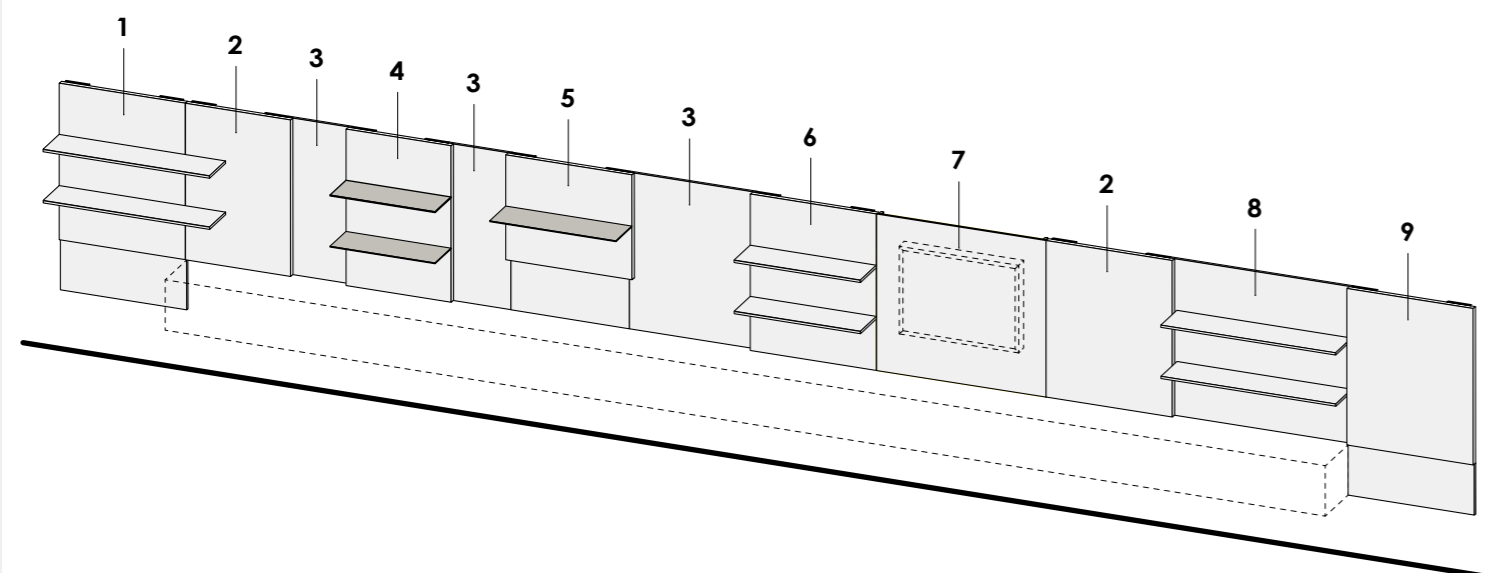

- 1 External panel Th 2.5 + Th 1.8 (initial) with protruding panel shelves Th 2.5
- 2 External panel Th 2.5
- 3 Internal panel Th 1.8
- 4 External panel Th 2.5 with Th 0.25 metal shelves
- 5 External panel Th 2.5 + Th 1.8 with metal shelf Th 0.25
- 6 External panel Th 2.5 with panel shelves Th 2.5
- 7 External TV stand panel Th 1.8
- 8 Internal panel Th 1.8 with panel shelves Th 2.5
- 9 External panel Th 2.5 + Th 1.8 (terminal)

## Internal panel Th 1.8

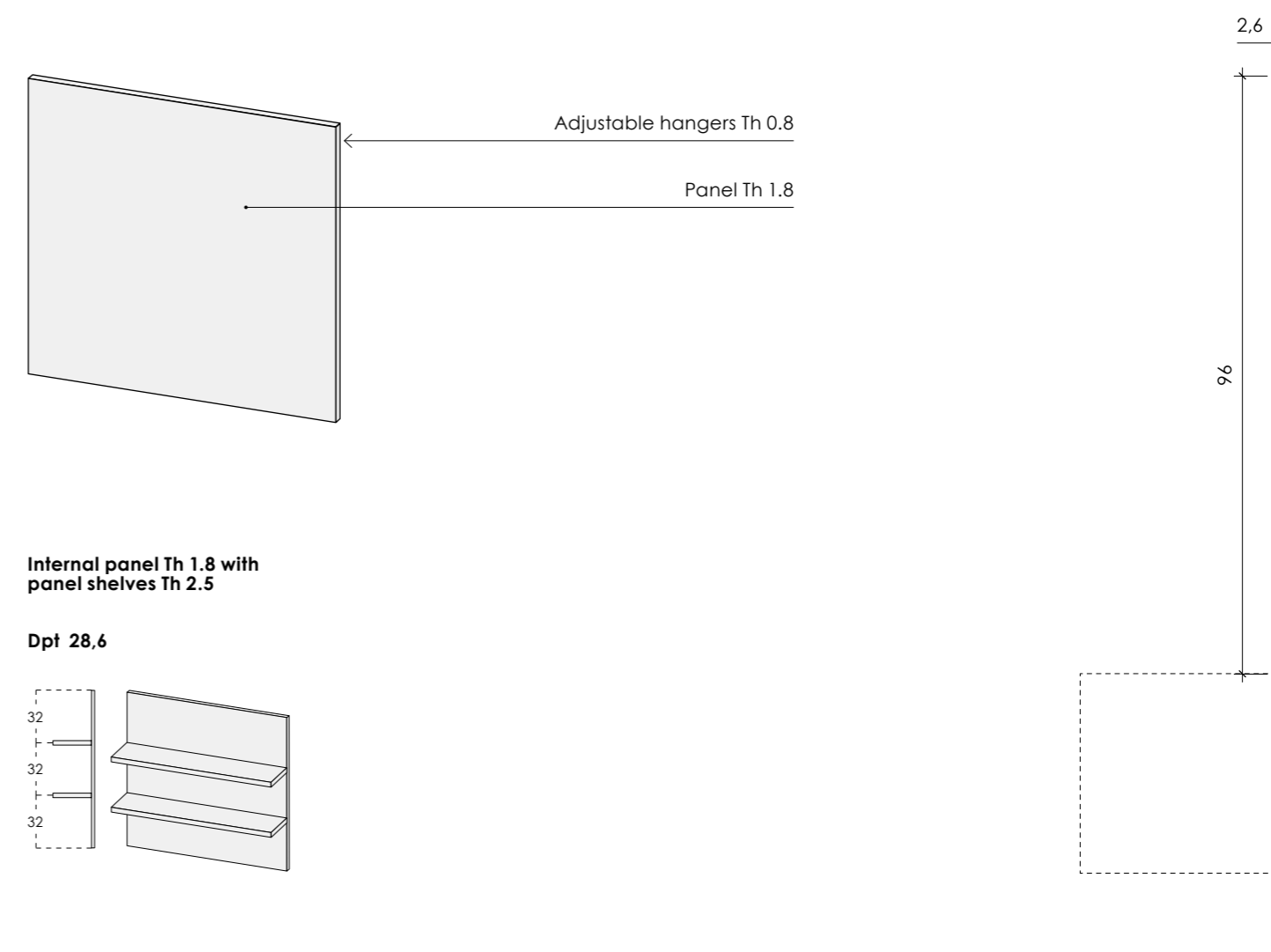

## Internal panel Th 1.8 with panel shelves Th 2.5

Dpt 28,6

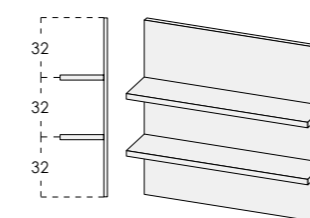

## Composition example

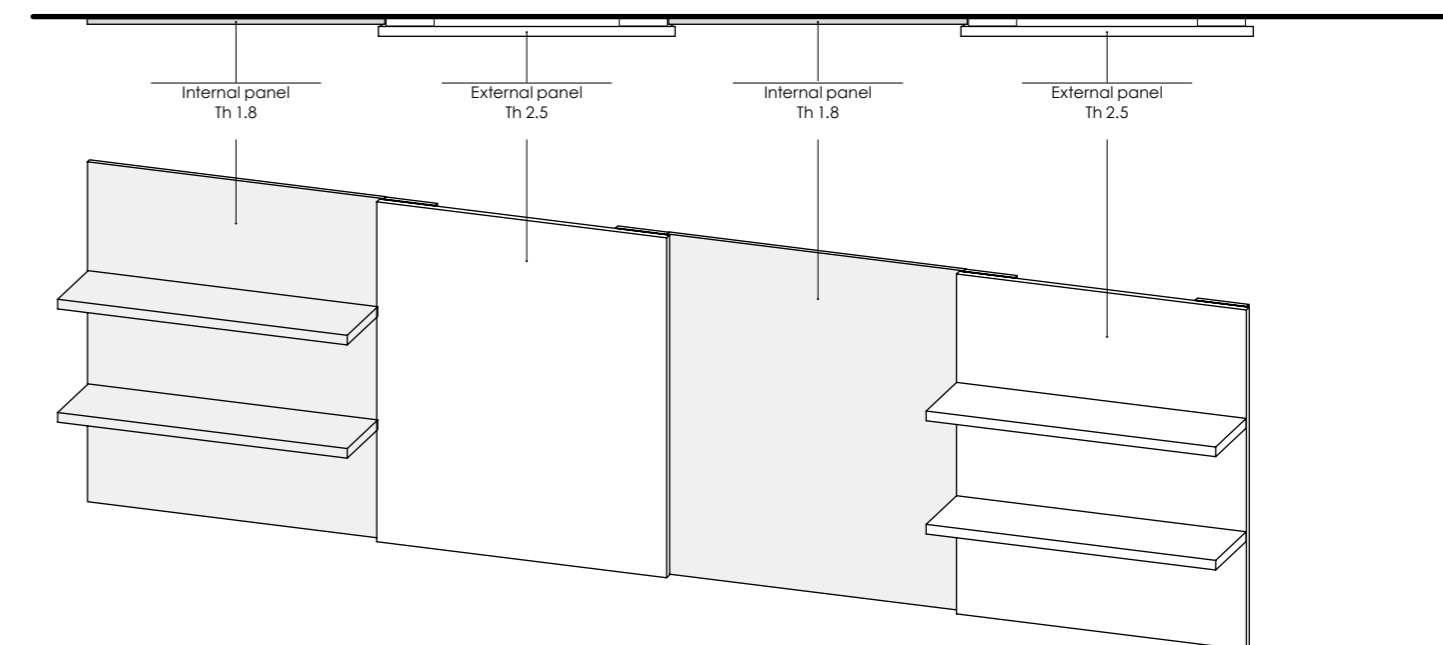

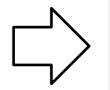

# DARSENA boiserie system

## External panel Th 2.5

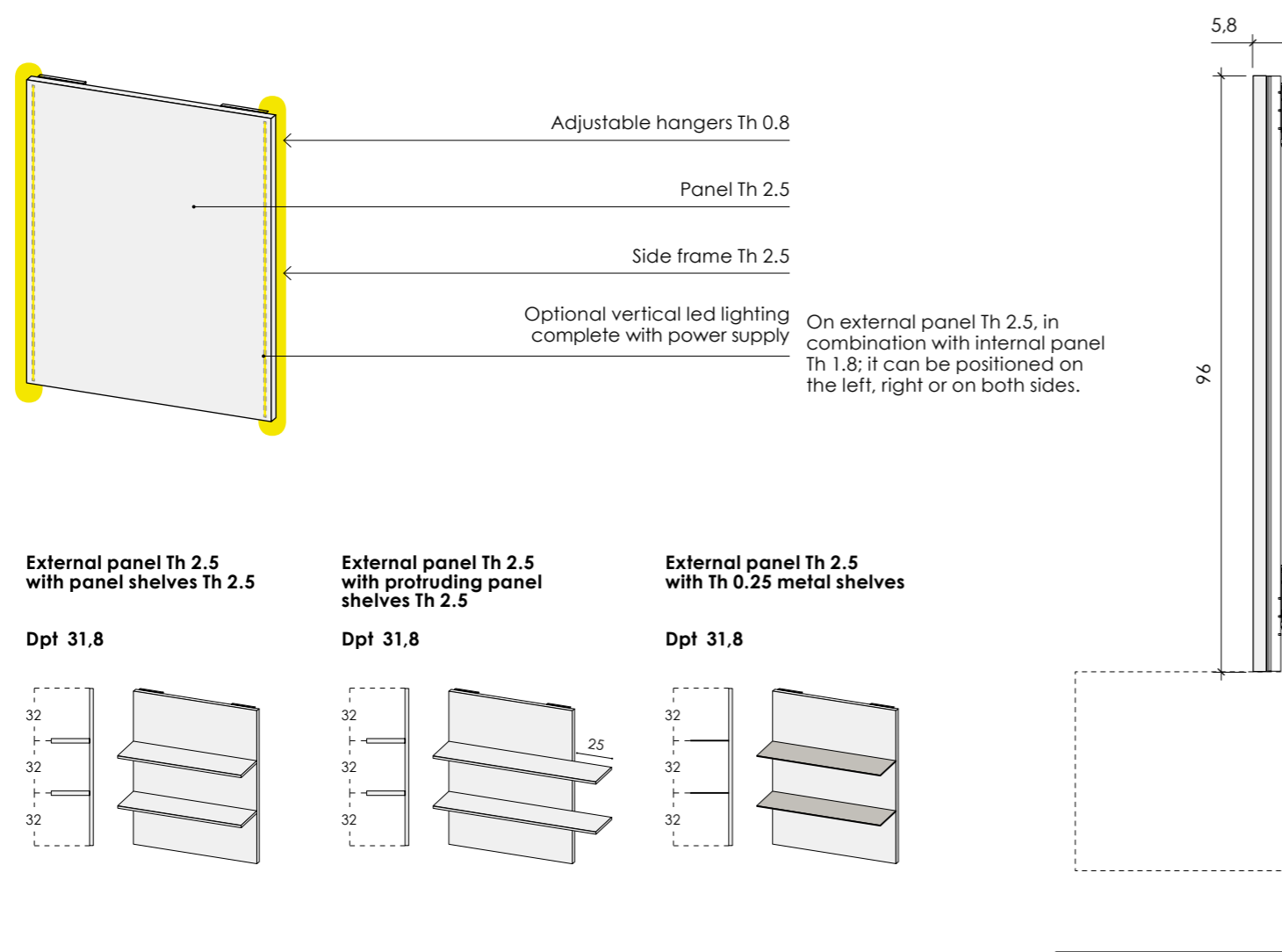

### Composition example

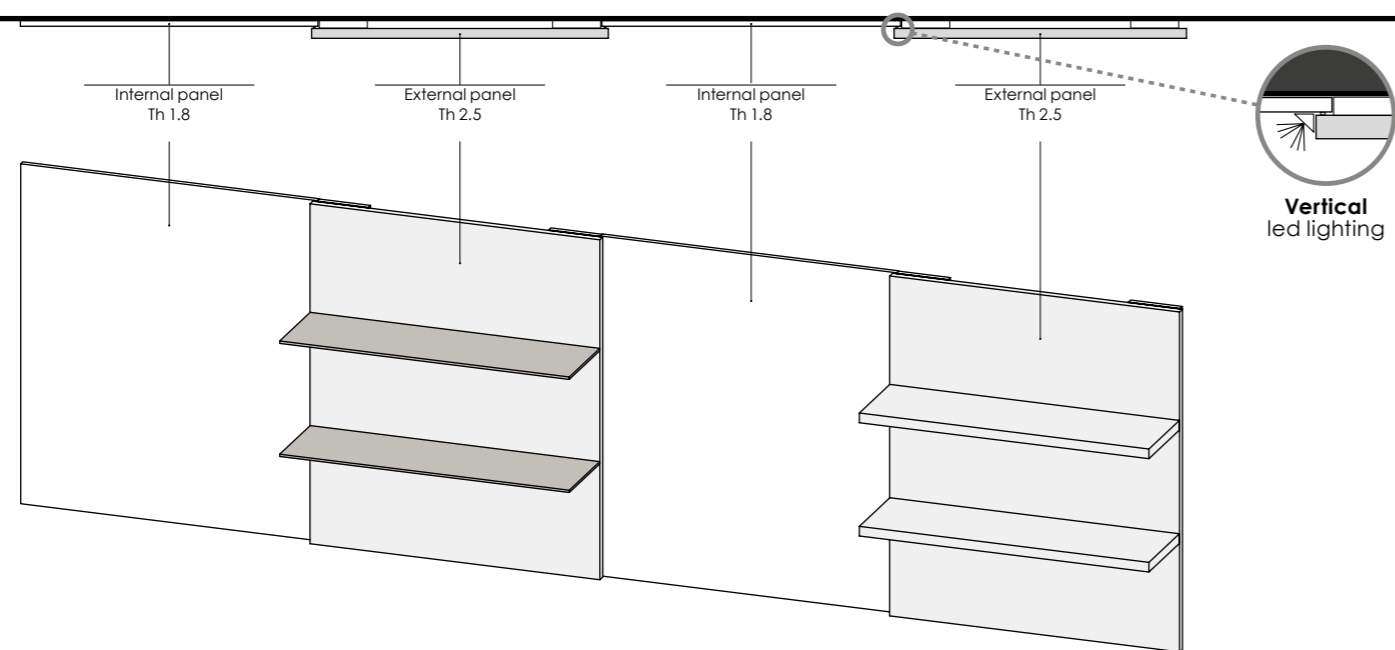

## External panel Th 2.5 + Th 1.8

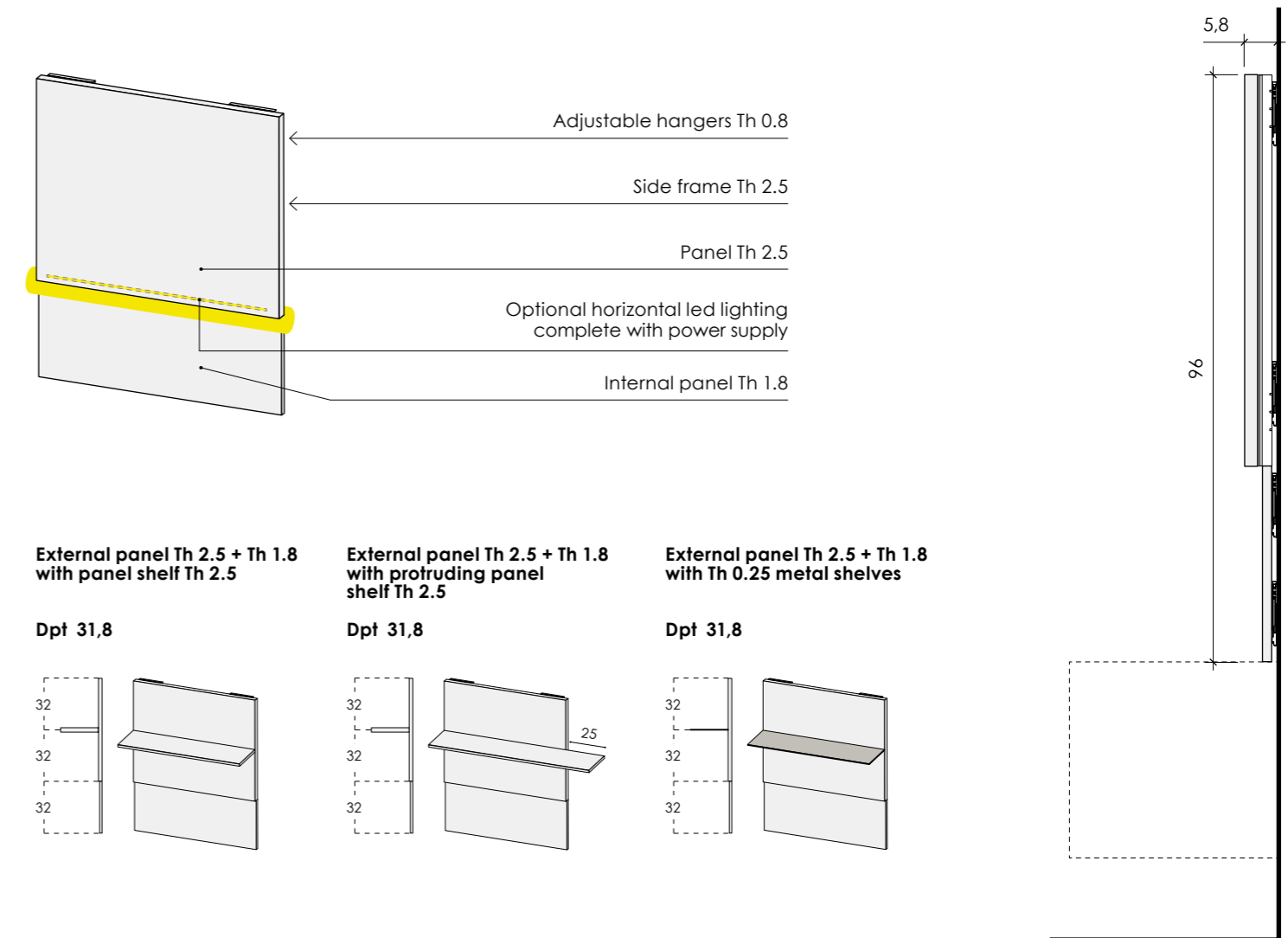

### Composition example

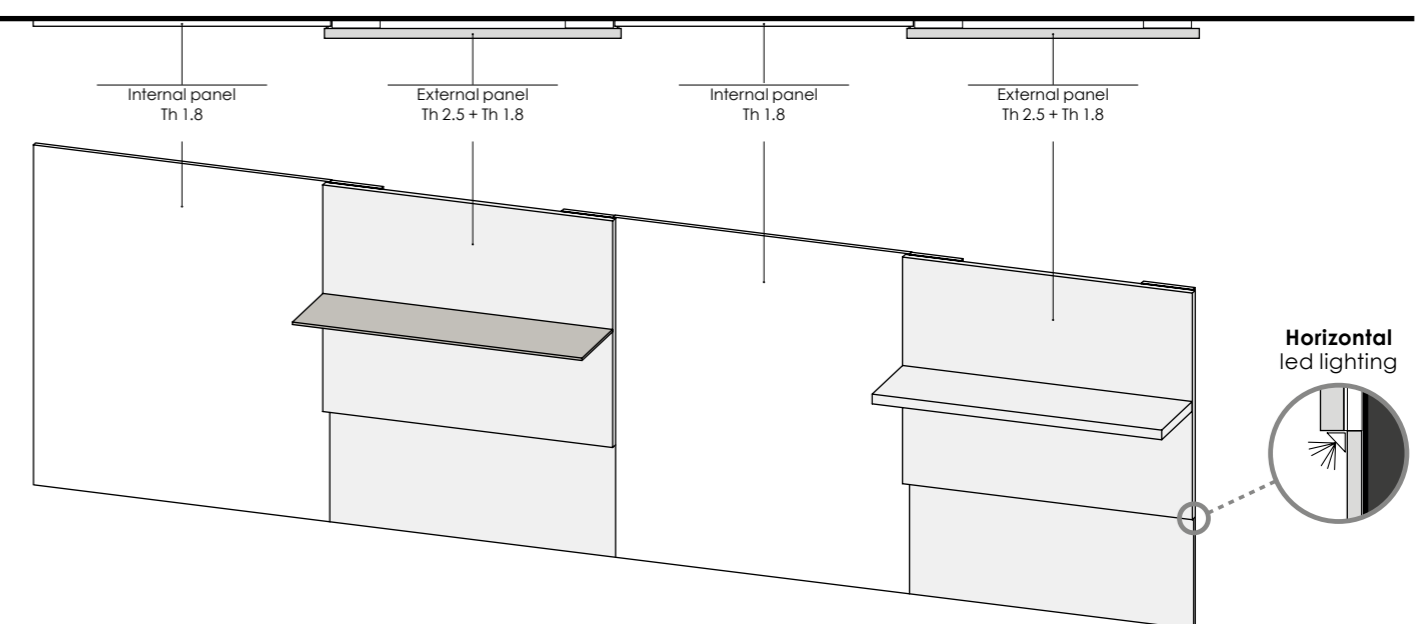

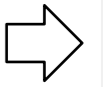

# DARSENA boiserie system

## External panel Th 2.5 + Th 1.8 (initial/terminal)

The outer panels Th 2.5 + Th 1.8 (start/end) Ht 129.8/129.4 must be positioned at the start or end of the composition in combination with suspended base units with top Th 1.4 or 1.8.

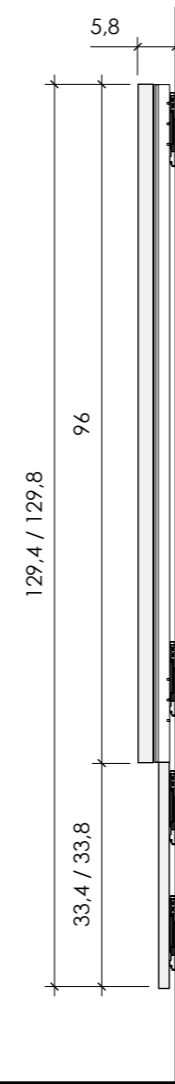
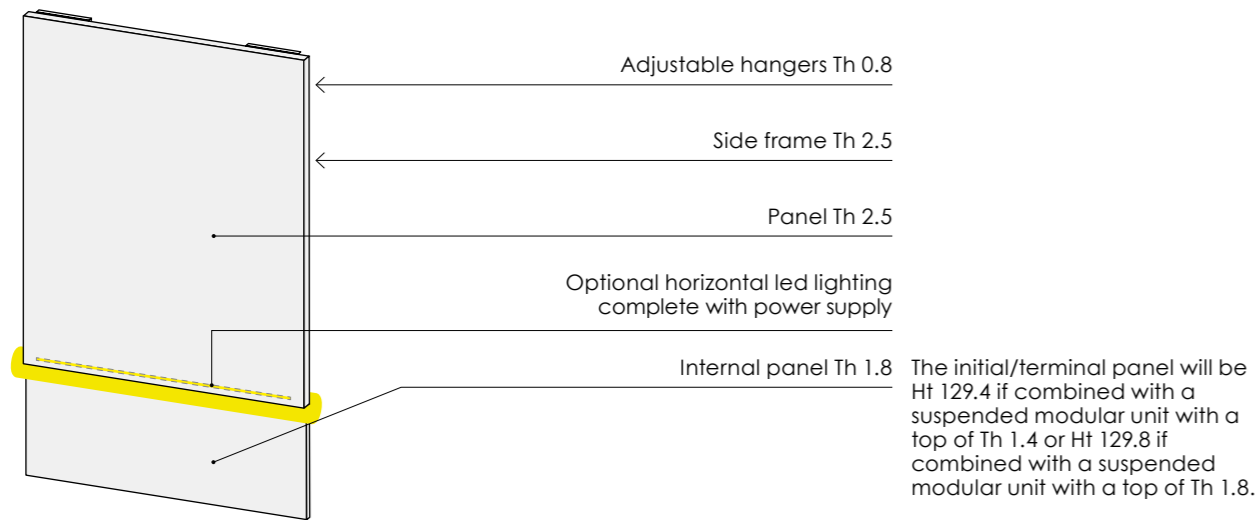

### External panel Th 2.5 + Th 1.8 with panel shelves Th 2.5

Dpt 31,8

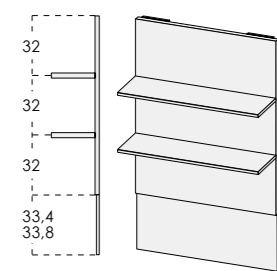

### External panel Th 2.5 + Th 1.8 with protruding panel shelves Th 2.5

Dpt 31,8

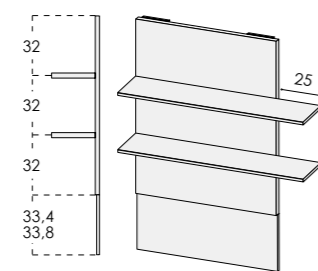

### External panel Th 2.5 + Th 1.8 with Th 0.25 metal shelves

Dpt 31,8

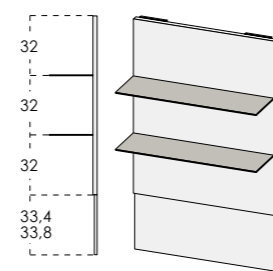

### Composition example

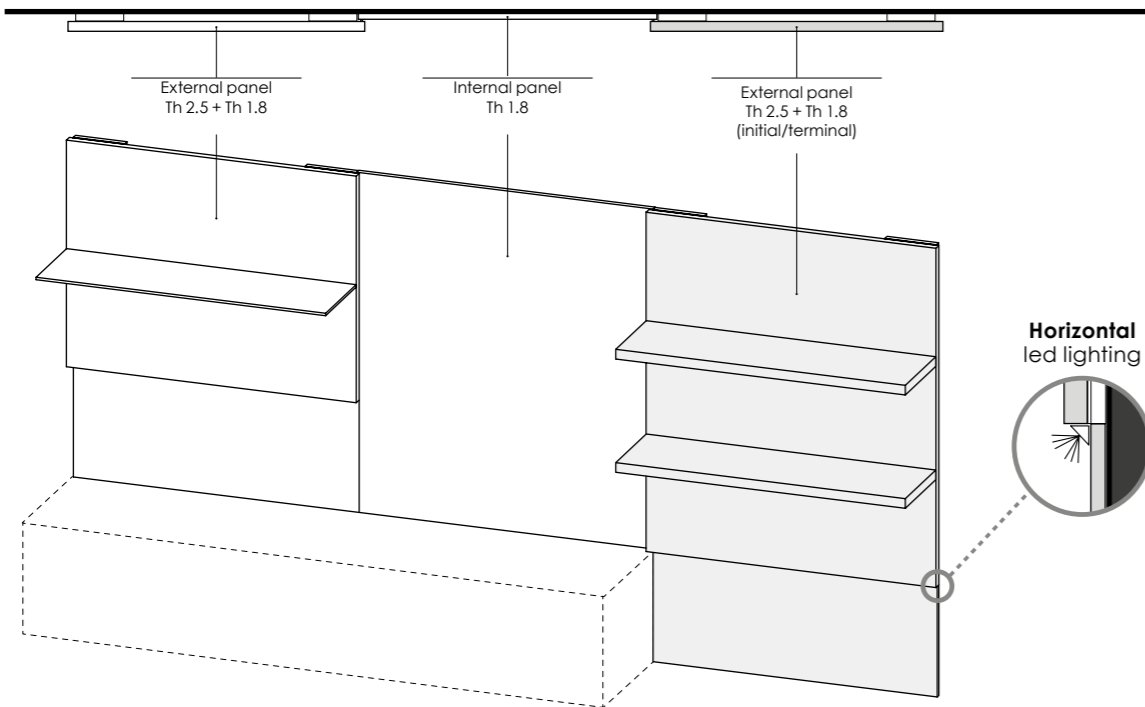

## External TV stand panel Th 1.8

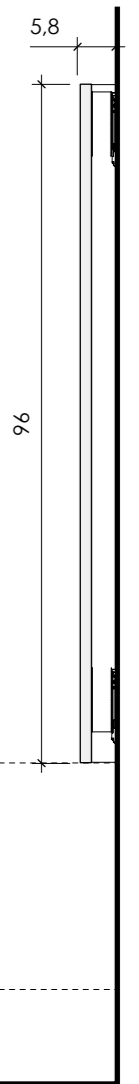
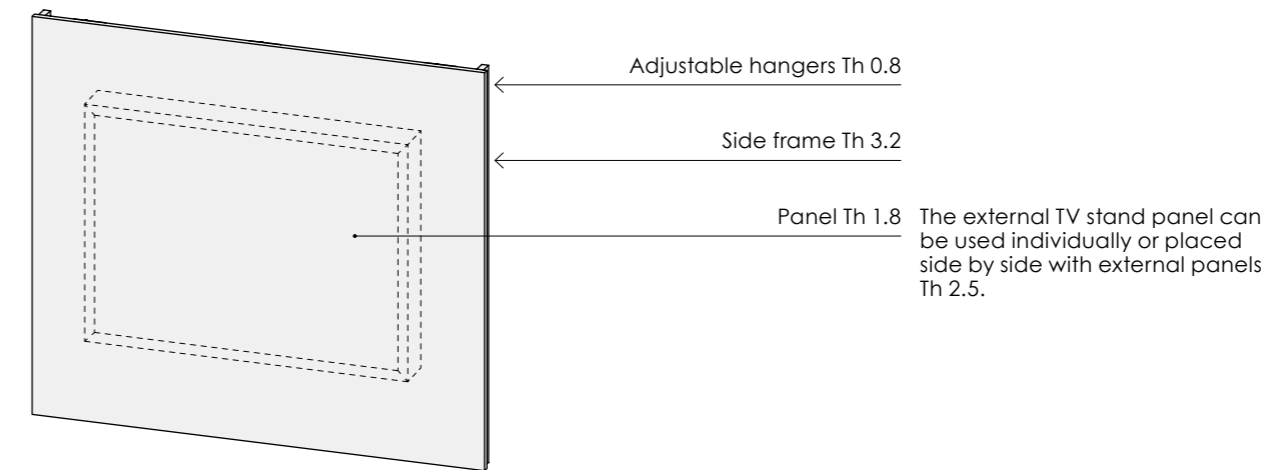

### Composition example

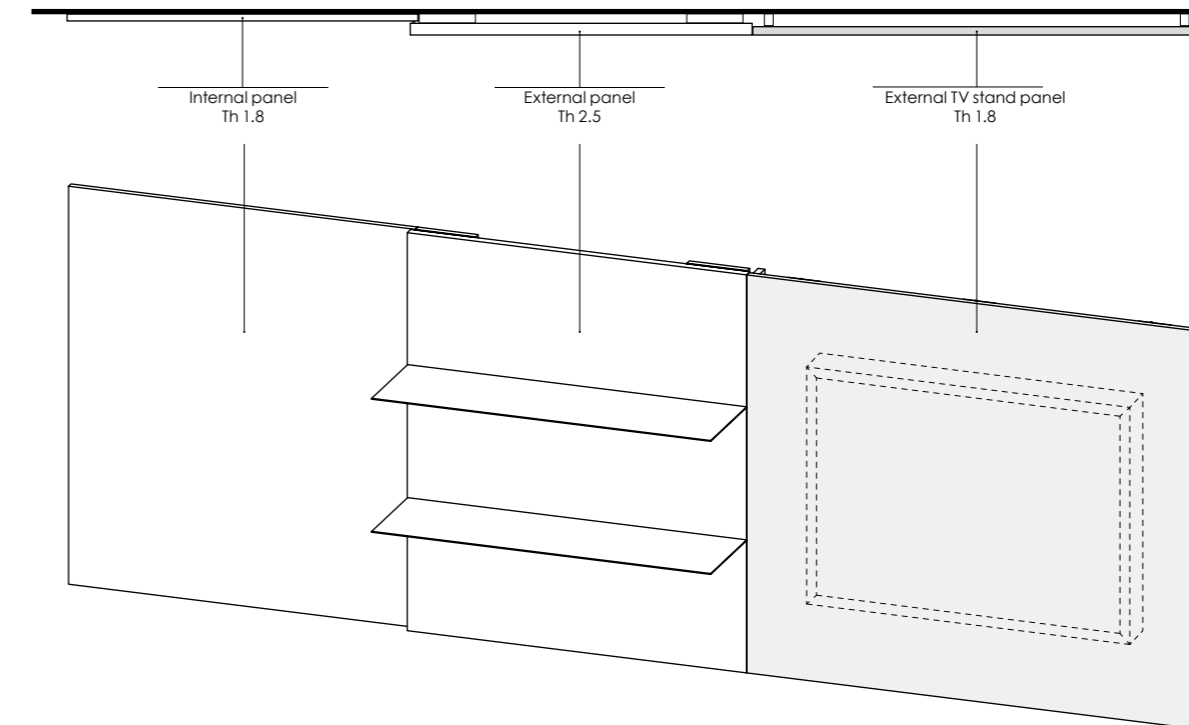

# DARSENA boiserie system

## Internal panel Th 1.8

Ht 96  
Dpt 2,6

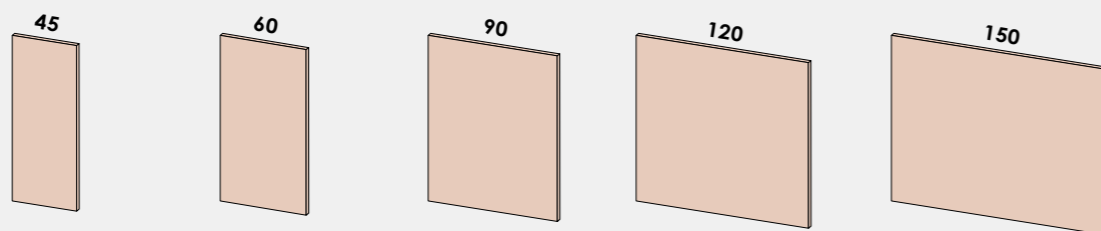

Code	PK62.00L	PK62.01A	PK62.02Y	PK62.03E	PK62.04M
------	----------	----------	----------	----------	----------

## Internal panel Th 1.8

Ht 96  
Dpt 2,6

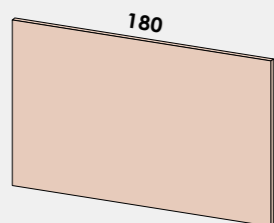

Custom-made  
Min 30 - Max 180

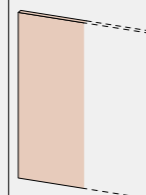

It can also be used individually

Code	PK62.05T	PK62.06Z		
------	----------	----------	--	--

## Internal panel Th 1.8 with shelves

Ht 96  
Dpt 28,6

Panel shelves Th 2.5

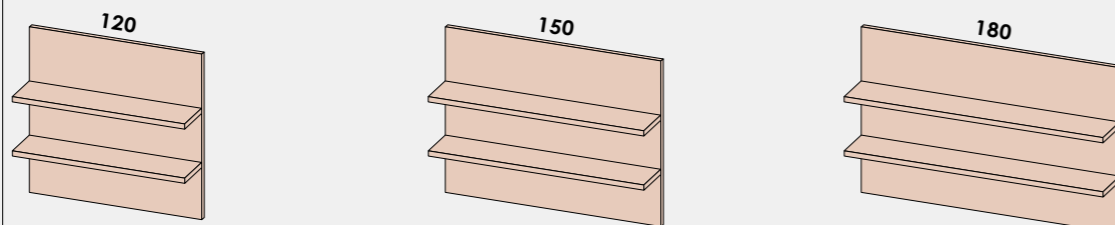

Code	PK62.07F	PK62.08N	PK62.09U	
------	----------	----------	----------	--

## External panel Th 2.5

Ht 96  
Dpt 5,8  
Optional vertical led lighting

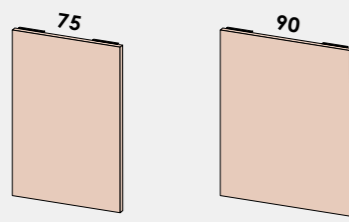

Custom-made  
Min 40 - Max 90

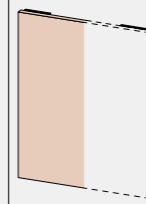

Code	PK62.10R	PK62.11X	PK62.12D		
------	----------	----------	----------	--	--

## External panel Th 2.5 with shelves

Ht 96  
Dpt 31,8  
Optional vertical led lighting

Panel shelves Th 2.5

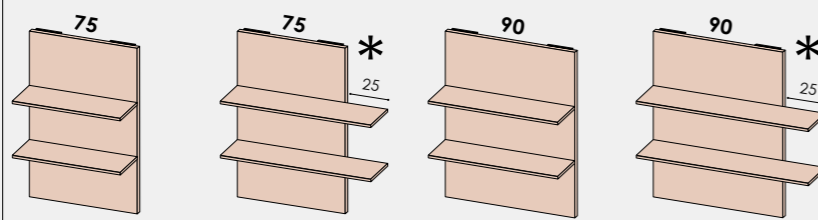

Metal shelves Th 0.25

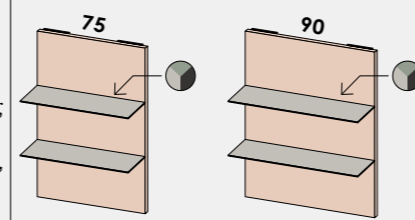

Code	PK62.13L	PK62.14S	PK62.15Y	PK62.16E	PK62.17M	PK62.18T
------	----------	----------	----------	----------	----------	----------

Components in **GROUP 3 colors**

\* Specify left or right (left image)



- Inner panels Th 1.8 must always be combined with outer panels Th 2.5.
- The outer panels Th 2.5 + Th 1.8 (start/end) Ht 129.4/129.8 must be positioned at the start or end of the composition in combination with suspended modular elements complete with top Th 1.4 or 1.8.
- The outer TV panel can be used singularly or placed alongside outer panels Th 2.5.

## Remote control



Code PV00.60M

The remote control is a wireless switch (single channel or multi-channel) using which it is possible to turn on, off, and regulate the brightness of the lamps connected to the receiving power adapter.  
1 remote control must be ordered for each power adapter.

## Bluetooth application board



Code PV00.59Q

The remote control module activates the Bluetooth function that allows you to manage the lights from your smartphone thanks to the dedicated App.  
1 board must be ordered for each power adapter.

## External panel Th 2.5 + 1.8

Ht 96  
Dpt 5,8  
Optional horizontal led lighting

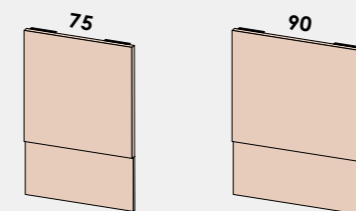

Code	PK62.19Z	PK62.20W			
------	----------	----------	--	--	--

## External panel Th 2.5 + 1.8 with shelf

Ht 96  
Dpt 31,8  
Optional horizontal led lighting

Panel shelves Th 2.5

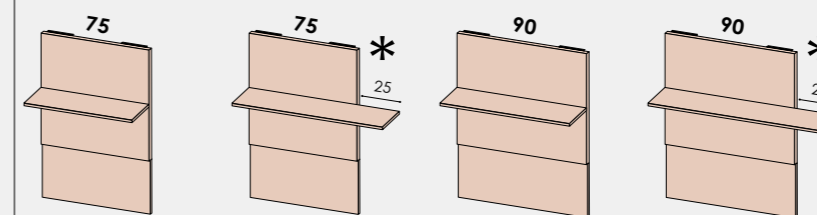

Metal shelves Th 0.25

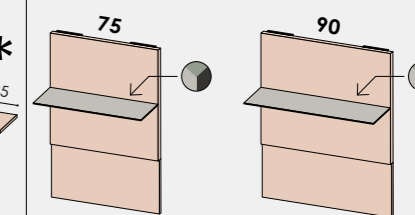

Code	PK62.21C	PK62.22K	PK62.23R	PK62.24X	PK62.25D	PK62.26L
------	----------	----------	----------	----------	----------	----------

## External panel Th 2.5 + 1.8 initial/terminal

Ht 129,4/129,8  
Dpt 5,8  
Optional horizontal led lighting

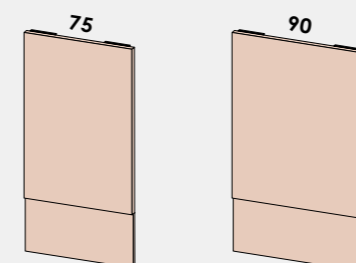

Code	PK62.27S	PK62.28Y			
------	----------	----------	--	--	--

## External panel Th 2.5 + 1.8 with shelves initial/terminal

Ht 129,4/129,8  
Dpt 31,8  
Optional horizontal led lighting

Panel shelves Th 2.5

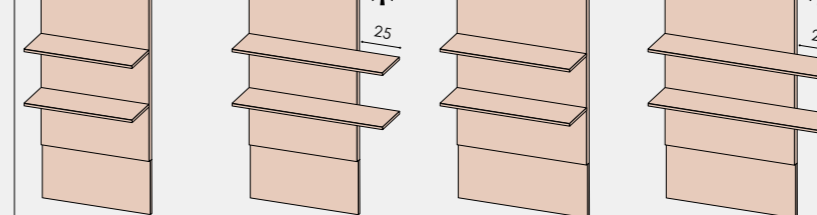

Metal shelves Th 0.25

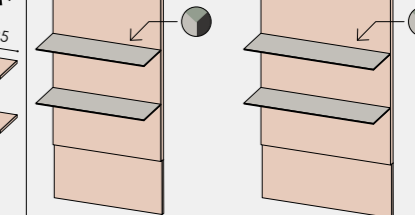

Code	PK62.29E	PK62.30B	PK62.31H	PK62.32Q	PK62.33W	PK62.34C
------	----------	----------	----------	----------	----------	----------

## External TV stand panel Th 1.8

Ht 96  
Dpt 5,8

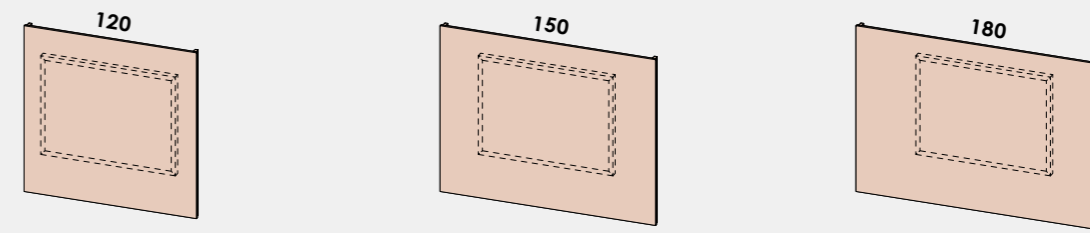

Code	PK62.35K	PK62.36R	PK62.37X
------	----------	----------	----------

**Maximum recommended load:**  
15 Kg for each panel shelf, net of the shelves.  
7.5 Kg for each metal shelf, net of the shelves.  
N.B. the load is intended as evenly distributed on the shelf.  
40 Kg for outer TV panel.

Colour correspondence key

<b>CARCASE color</b>	Leather grey <b>LG7H</b>	<b>GROUP 3 colors</b>																																									
		Rovere white <b>RW3Q</b>	Rovere Dorian <b>RD5T</b>	Ciliegio bianco <b>CB6K</b>	Noce naturale <b>NN7H</b>	Noce <b>NC4B</b>	Eucalipto <b>CL1X</b>	Malta <b>ML7H</b>	Feltro <b>FL8X</b>	Cemento Masdar <b>CM3Q</b>	Bianco opaco <b>B17A</b>	Desert <b>DS9L</b>	Canapa <b>CN1X</b>	Moka <b>MK6B</b>	Grigio Dorian <b>GL4R</b>																												
	Basalto <b>BS5T</b>	Grigio titanio <b>GZ8T</b>	Agave <b>GV7A</b>	Verde Alpi <b>VA5T</b>	Cadaques <b>CQ3Q</b>	Blu opale <b>BO7H</b>																																					
	Central aluminium frame side colour <b>CG8X</b>																																										
<b>Types and colors FRONT</b>	STYLE Th 1,8	<table border="1"> <tr> <td>Rovere white <b>RW3Q</b></td> <td>Rovere Dorian <b>RD5T</b></td> <td>Ciliegio bianco <b>CB6K</b></td> <td>Noce naturale <b>NN7H</b></td> <td>Noce <b>NC4B</b></td> <td>Eucalipto <b>CL1X</b></td> <td>Malta <b>ML7H</b></td> </tr> <tr> <td>Feltro <b>FL8X</b></td> <td>Cemento Masdar <b>CM3Q</b></td> <td>Bianco opaco <b>B17A</b></td> <td>Desert <b>DS9L</b></td> <td>Canapa <b>CN1X</b></td> <td>Moka <b>MK6B</b></td> <td>Grigio Dorian <b>GL4R</b></td> </tr> <tr> <td>Basalto <b>BS5T</b></td> <td>Grigio titanio <b>GZ8T</b></td> <td>Agave <b>GV7A</b></td> <td>Verde Alpi <b>VA5T</b></td> <td>Cadaques <b>CQ3Q</b></td> <td>Blu opale <b>BO7H</b></td> <td></td> </tr> <tr> <td>Bianco UV <b>BU3Q</b></td> <td colspan="6"></td> </tr> </table>														Rovere white <b>RW3Q</b>	Rovere Dorian <b>RD5T</b>	Ciliegio bianco <b>CB6K</b>	Noce naturale <b>NN7H</b>	Noce <b>NC4B</b>	Eucalipto <b>CL1X</b>	Malta <b>ML7H</b>	Feltro <b>FL8X</b>	Cemento Masdar <b>CM3Q</b>	Bianco opaco <b>B17A</b>	Desert <b>DS9L</b>	Canapa <b>CN1X</b>	Moka <b>MK6B</b>	Grigio Dorian <b>GL4R</b>	Basalto <b>BS5T</b>	Grigio titanio <b>GZ8T</b>	Agave <b>GV7A</b>	Verde Alpi <b>VA5T</b>	Cadaques <b>CQ3Q</b>	Blu opale <b>BO7H</b>		Bianco UV <b>BU3Q</b>						
		Rovere white <b>RW3Q</b>	Rovere Dorian <b>RD5T</b>	Ciliegio bianco <b>CB6K</b>	Noce naturale <b>NN7H</b>	Noce <b>NC4B</b>	Eucalipto <b>CL1X</b>	Malta <b>ML7H</b>																																			
		Feltro <b>FL8X</b>	Cemento Masdar <b>CM3Q</b>	Bianco opaco <b>B17A</b>	Desert <b>DS9L</b>	Canapa <b>CN1X</b>	Moka <b>MK6B</b>	Grigio Dorian <b>GL4R</b>																																			
		Basalto <b>BS5T</b>	Grigio titanio <b>GZ8T</b>	Agave <b>GV7A</b>	Verde Alpi <b>VA5T</b>	Cadaques <b>CQ3Q</b>	Blu opale <b>BO7H</b>																																				
	Bianco UV <b>BU3Q</b>																																										
	matte																																										
	glossy																																										
	CONCRETA Th 2,5	<table border="1"> <tr> <td>Rovere white <b>RW3Q</b></td> <td>Rovere Dorian <b>RD5T</b></td> <td>Ciliegio bianco <b>CB6K</b></td> <td>Noce naturale <b>NN7H</b></td> <td>Noce <b>NC4B</b></td> <td>Eucalipto <b>CL1X</b></td> <td>Malta <b>ML7H</b></td> </tr> <tr> <td>Feltro <b>FL8X</b></td> <td>Cemento Masdar <b>CM3Q</b></td> <td>Bianco opaco <b>B17A</b></td> <td>Desert <b>DS9L</b></td> <td>Canapa <b>CN1X</b></td> <td>Moka <b>MK6B</b></td> <td>Grigio Dorian <b>GL4R</b></td> </tr> <tr> <td>Basalto <b>BS5T</b></td> <td>Grigio titanio <b>GZ8T</b></td> <td>Agave <b>GV7A</b></td> <td>Verde Alpi <b>VA5T</b></td> <td>Cadaques <b>CQ3Q</b></td> <td>Blu opale <b>BO7H</b></td> <td></td> </tr> </table>														Rovere white <b>RW3Q</b>	Rovere Dorian <b>RD5T</b>	Ciliegio bianco <b>CB6K</b>	Noce naturale <b>NN7H</b>	Noce <b>NC4B</b>	Eucalipto <b>CL1X</b>	Malta <b>ML7H</b>	Feltro <b>FL8X</b>	Cemento Masdar <b>CM3Q</b>	Bianco opaco <b>B17A</b>	Desert <b>DS9L</b>	Canapa <b>CN1X</b>	Moka <b>MK6B</b>	Grigio Dorian <b>GL4R</b>	Basalto <b>BS5T</b>	Grigio titanio <b>GZ8T</b>	Agave <b>GV7A</b>	Verde Alpi <b>VA5T</b>	Cadaques <b>CQ3Q</b>	Blu opale <b>BO7H</b>								
		Rovere white <b>RW3Q</b>	Rovere Dorian <b>RD5T</b>	Ciliegio bianco <b>CB6K</b>	Noce naturale <b>NN7H</b>	Noce <b>NC4B</b>	Eucalipto <b>CL1X</b>	Malta <b>ML7H</b>																																			
		Feltro <b>FL8X</b>	Cemento Masdar <b>CM3Q</b>	Bianco opaco <b>B17A</b>	Desert <b>DS9L</b>	Canapa <b>CN1X</b>	Moka <b>MK6B</b>	Grigio Dorian <b>GL4R</b>																																			
Basalto <b>BS5T</b>	Grigio titanio <b>GZ8T</b>	Agave <b>GV7A</b>	Verde Alpi <b>VA5T</b>	Cadaques <b>CQ3Q</b>	Blu opale <b>BO7H</b>																																						
CUTTING Th 2,5	<table border="1"> <tr> <td>Rovere white <b>RW3Q</b></td> <td>Rovere Dorian <b>RD5T</b></td> <td>Ciliegio bianco <b>CB6K</b></td> <td>Noce naturale <b>NN7H</b></td> <td>Noce <b>NC4B</b></td> <td>Eucalipto <b>CL1X</b></td> <td>Malta <b>ML7H</b></td> </tr> <tr> <td>Feltro <b>FL8X</b></td> <td>Cemento Masdar <b>CM3Q</b></td> <td>Bianco opaco <b>B17A</b></td> <td>Desert <b>DS9L</b></td> <td>Canapa <b>CN1X</b></td> <td>Moka <b>MK6B</b></td> <td>Grigio Dorian <b>GL4R</b></td> </tr> <tr> <td>Basalto <b>BS5T</b></td> <td>Grigio titanio <b>GZ8T</b></td> <td>Agave <b>GV7A</b></td> <td>Verde Alpi <b>VA5T</b></td> <td>Cadaques <b>CQ3Q</b></td> <td>Blu opale <b>BO7H</b></td> <td></td> </tr> </table>														Rovere white <b>RW3Q</b>	Rovere Dorian <b>RD5T</b>	Ciliegio bianco <b>CB6K</b>	Noce naturale <b>NN7H</b>	Noce <b>NC4B</b>	Eucalipto <b>CL1X</b>	Malta <b>ML7H</b>	Feltro <b>FL8X</b>	Cemento Masdar <b>CM3Q</b>	Bianco opaco <b>B17A</b>	Desert <b>DS9L</b>	Canapa <b>CN1X</b>	Moka <b>MK6B</b>	Grigio Dorian <b>GL4R</b>	Basalto <b>BS5T</b>	Grigio titanio <b>GZ8T</b>	Agave <b>GV7A</b>	Verde Alpi <b>VA5T</b>	Cadaques <b>CQ3Q</b>	Blu opale <b>BO7H</b>									
	Rovere white <b>RW3Q</b>	Rovere Dorian <b>RD5T</b>	Ciliegio bianco <b>CB6K</b>	Noce naturale <b>NN7H</b>	Noce <b>NC4B</b>	Eucalipto <b>CL1X</b>	Malta <b>ML7H</b>																																				
	Feltro <b>FL8X</b>	Cemento Masdar <b>CM3Q</b>	Bianco opaco <b>B17A</b>	Desert <b>DS9L</b>	Canapa <b>CN1X</b>	Moka <b>MK6B</b>	Grigio Dorian <b>GL4R</b>																																				
Basalto <b>BS5T</b>	Grigio titanio <b>GZ8T</b>	Agave <b>GV7A</b>	Verde Alpi <b>VA5T</b>	Cadaques <b>CQ3Q</b>	Blu opale <b>BO7H</b>																																						
CUTTING PLUS Th 2,5	<p>Specify the color of the handle (the internal insert is available in all front colors)</p> <table border="1"> <tr> <td>Bianco opaco <b>B17A</b></td> <td>Desert <b>DS9L</b></td> <td>Canapa <b>CN1X</b></td> <td>Moka <b>MK6B</b></td> <td>Grigio Dorian <b>GL4R</b></td> <td>Basalto <b>BS5T</b></td> <td>Grigio titanio <b>GZ8T</b></td> </tr> <tr> <td>Agave <b>GV7A</b></td> <td>Verde Alpi <b>VA5T</b></td> <td>Cadaques <b>CQ3Q</b></td> <td>Blu opale <b>BO7H</b></td> <td colspan="3"></td> </tr> </table>														Bianco opaco <b>B17A</b>	Desert <b>DS9L</b>	Canapa <b>CN1X</b>	Moka <b>MK6B</b>	Grigio Dorian <b>GL4R</b>	Basalto <b>BS5T</b>	Grigio titanio <b>GZ8T</b>	Agave <b>GV7A</b>	Verde Alpi <b>VA5T</b>	Cadaques <b>CQ3Q</b>	Blu opale <b>BO7H</b>																		
Bianco opaco <b>B17A</b>	Desert <b>DS9L</b>	Canapa <b>CN1X</b>	Moka <b>MK6B</b>	Grigio Dorian <b>GL4R</b>	Basalto <b>BS5T</b>	Grigio titanio <b>GZ8T</b>																																					
Agave <b>GV7A</b>	Verde Alpi <b>VA5T</b>	Cadaques <b>CQ3Q</b>	Blu opale <b>BO7H</b>																																								
WINDOW Th 2,1	<table border="1"> <tr> <td>Trasparente <b>TR9M</b></td> <td>Trasparente fumé <b>FT8P</b></td> <td>Stop-sol <b>ST6P</b></td> <td>Specchio <b>SP7L</b></td> <td colspan="10"></td> </tr> <tr> <td>Aluminio <b>AL1A</b></td> <td>Titan grey <b>TG7H</b></td> <td colspan="12"></td> </tr> </table>														Trasparente <b>TR9M</b>	Trasparente fumé <b>FT8P</b>	Stop-sol <b>ST6P</b>	Specchio <b>SP7L</b>											Aluminio <b>AL1A</b>	Titan grey <b>TG7H</b>													
	Trasparente <b>TR9M</b>	Trasparente fumé <b>FT8P</b>	Stop-sol <b>ST6P</b>	Specchio <b>SP7L</b>																																							
Aluminio <b>AL1A</b>	Titan grey <b>TG7H</b>																																										
	<p>Specify the color of the aluminum frame</p> <table border="1"> <tr> <td>Aluminio <b>AL1A</b></td> <td>Titan grey <b>TG7H</b></td> <td colspan="12"></td> </tr> </table>														Aluminio <b>AL1A</b>	Titan grey <b>TG7H</b>																											
Aluminio <b>AL1A</b>	Titan grey <b>TG7H</b>																																										

Modular wardrobes

Side panel hole layout	480
STYLE fronts Th 1.8	482
CONCRETA fronts Th 2.5	483
CUTTING fronts Th 2.5	484
CUTTING PLUS fronts Th 2.5	485
WINDOW fronts Th 2.1	486
STYLE sliding doors Th 1.8	488
MOSAICO sliding doors Th 1.8	489
FREEDOM sliding doors Th 1.8	490
CONCRETA sliding doors Th 2.5	491
RAIL sliding doors Th 2.5/1.8	492
CUTTING sliding doors Th 2.5	493
Handles	494
Handle positions	496
Hinged doors	498
Custom cuts	500
Filler strips for modular wardrobes	502
Hardware	503
Accessories for modular wardrobes	504
Power adapters and switches	510



# Side panel hole layout

For proper customisation of the side panels, the internal equipment of the wardrobe must be graphically represented using our graphic software.

## Customised hole layout for side panel

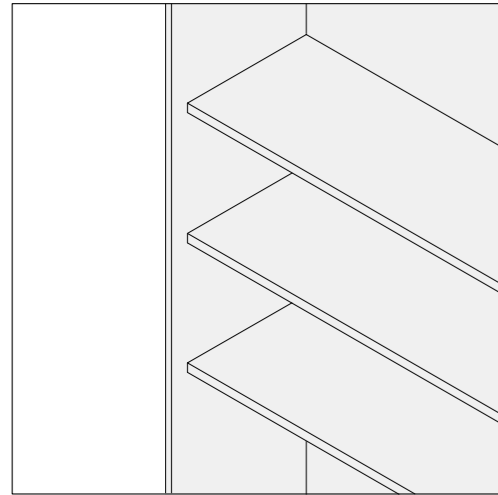

## Complete hole layout for side panel

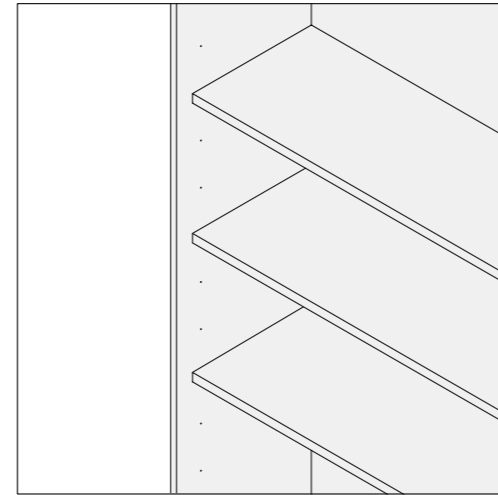

## Swing wardrobe hole layout

Front view (the measurements refer to the height of the side panel, excluding the foot).

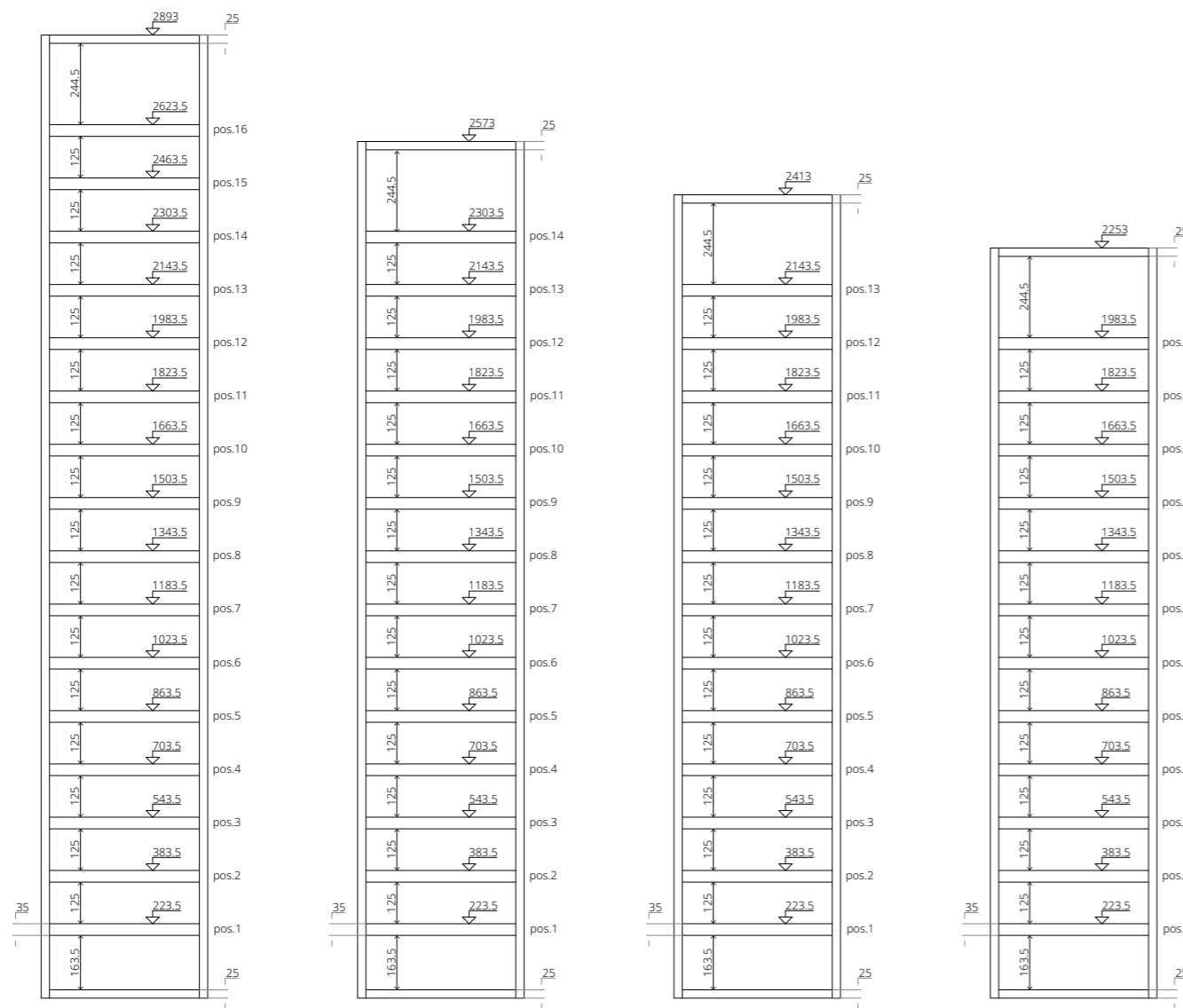

## Sliding wardrobe hole layout

Front view (the measurements refer to the height of the side panel, excluding the foot).

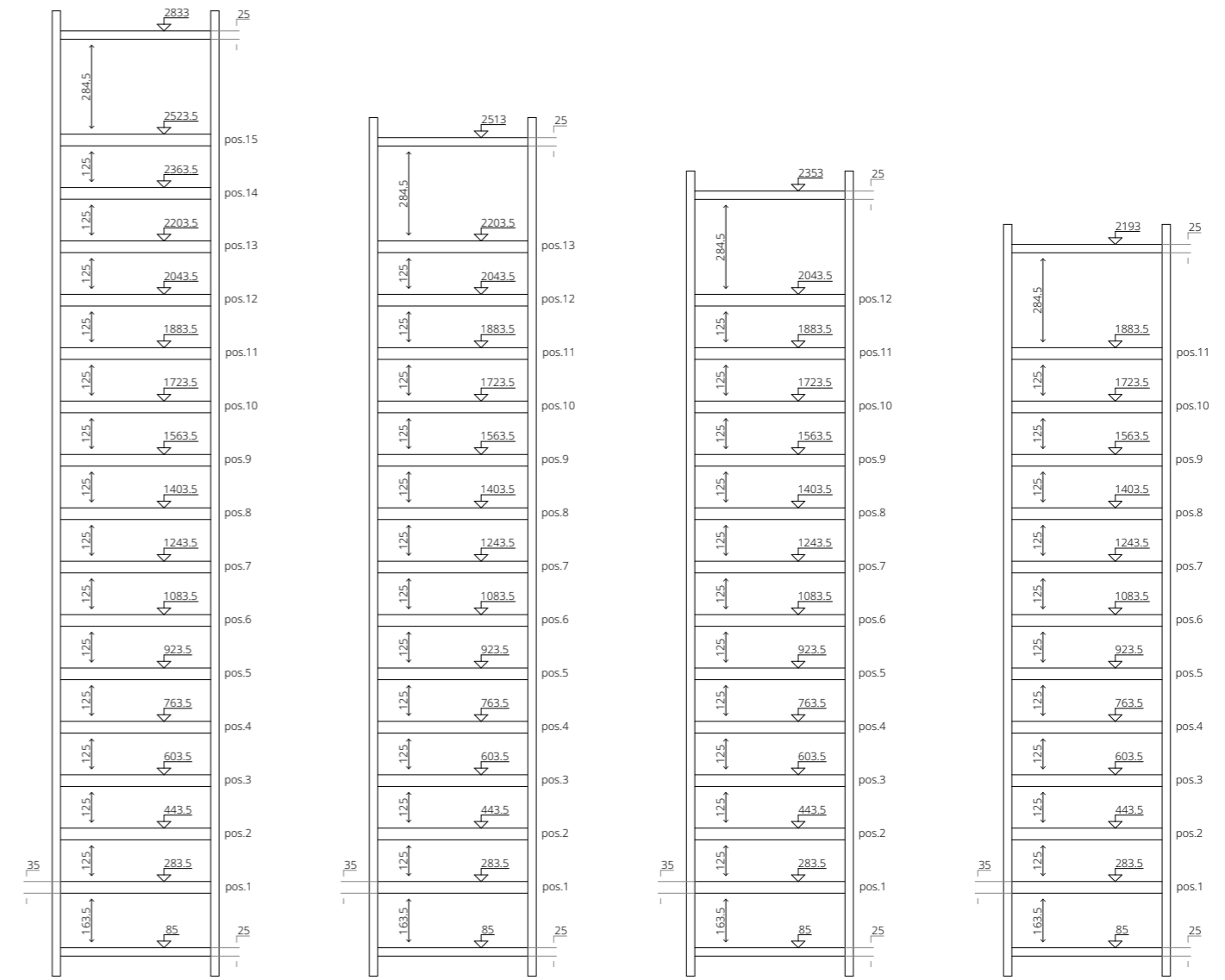

## STYLE fronts Th 1.8

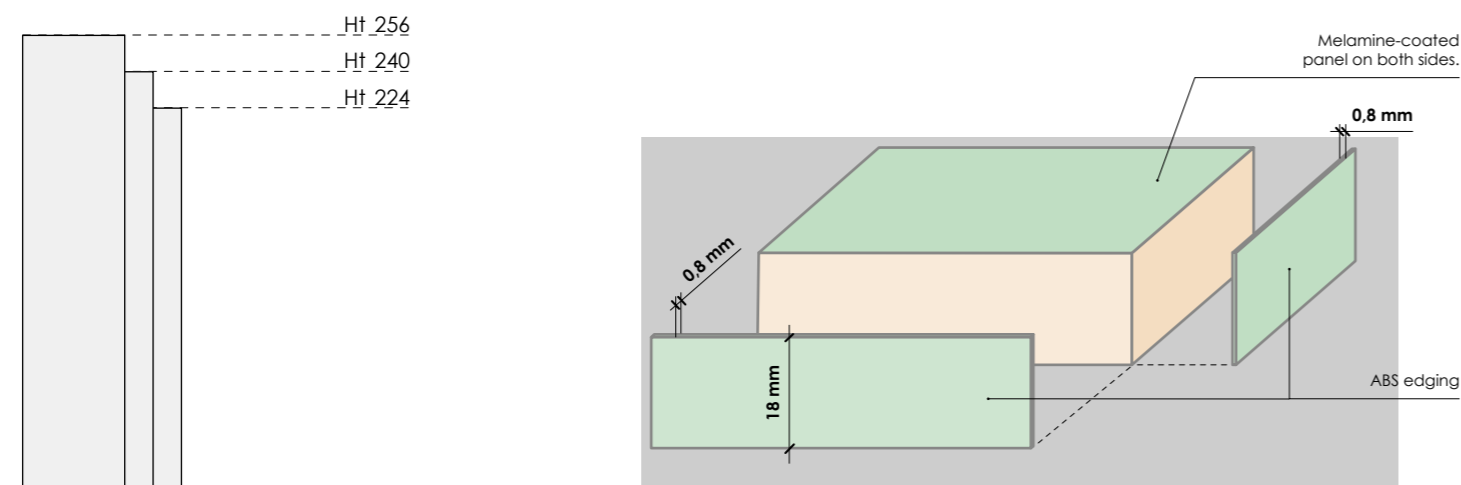
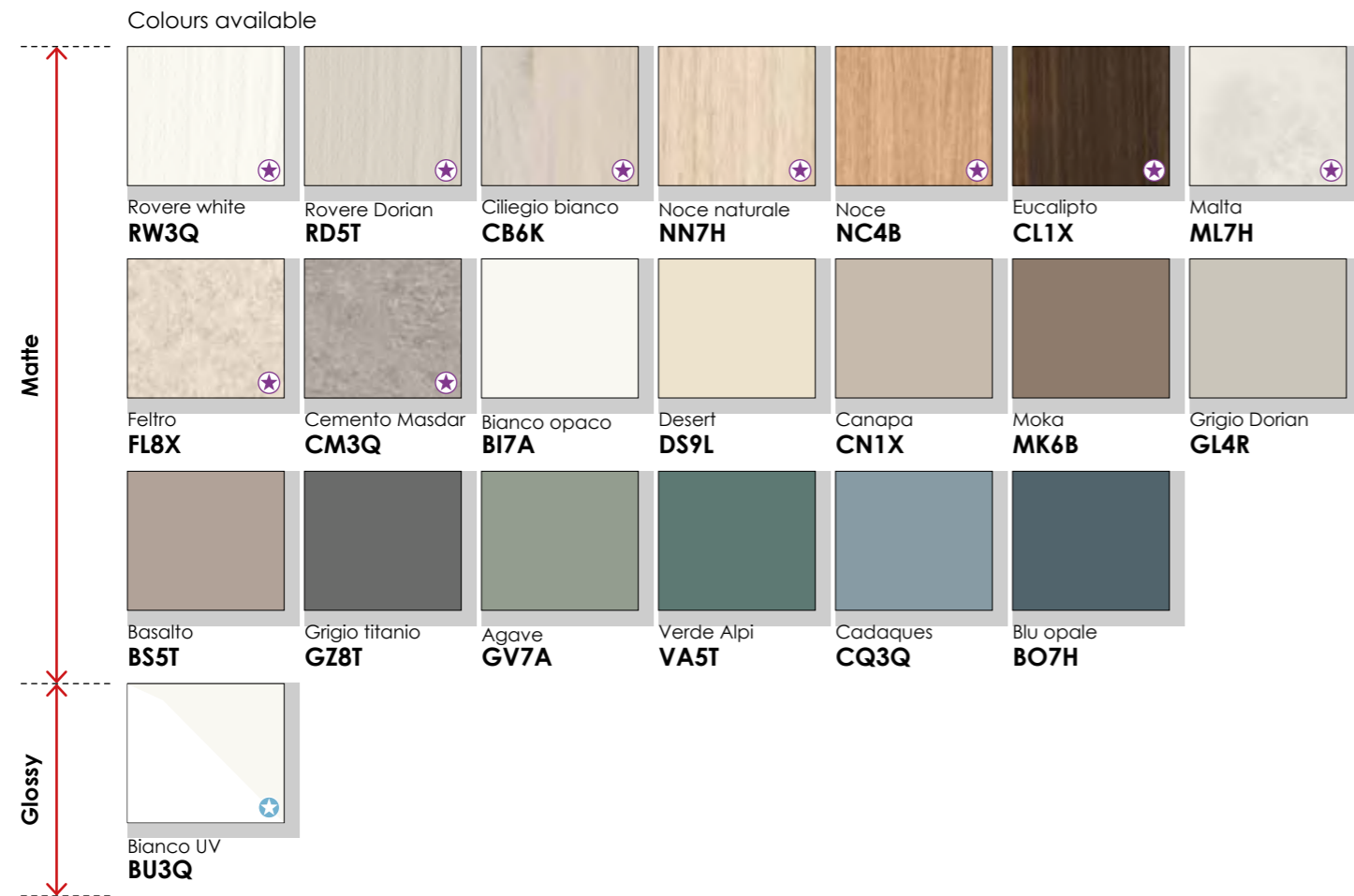

Doors W 30, 45, 50 and 60

- Each door has 4 adjustable hinges with soft closure; corner wardrobes have 165° hinges.
- In units W 90 with doors W 30 + W 60 the direction is determined by the position of the door W 60; only one handle is provided and it is positioned on the L 60 door.
- Lower heights and widths are permitted.

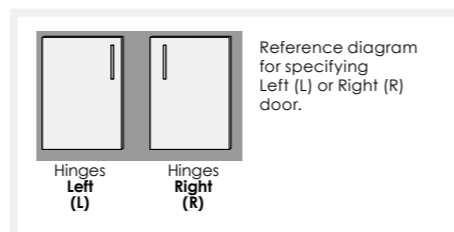

- ✳ Finishing with textured effect
- ✳ UV glossy finishing

## CONCRETA fronts Th 2.5

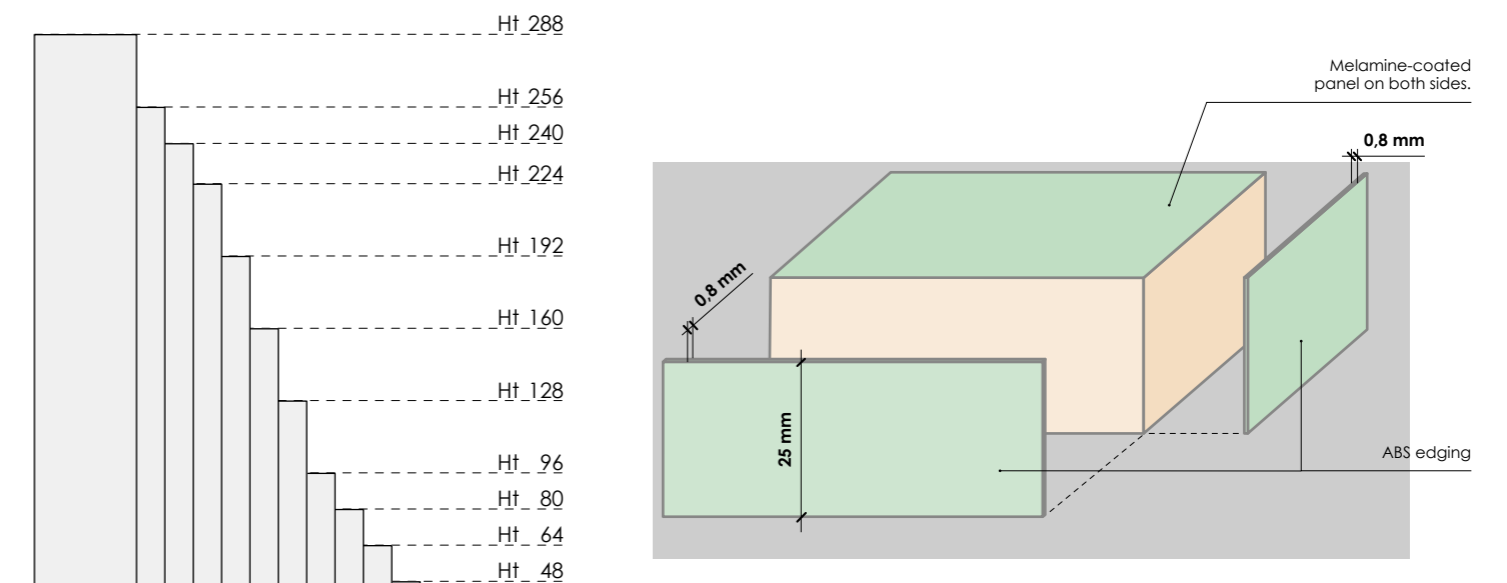
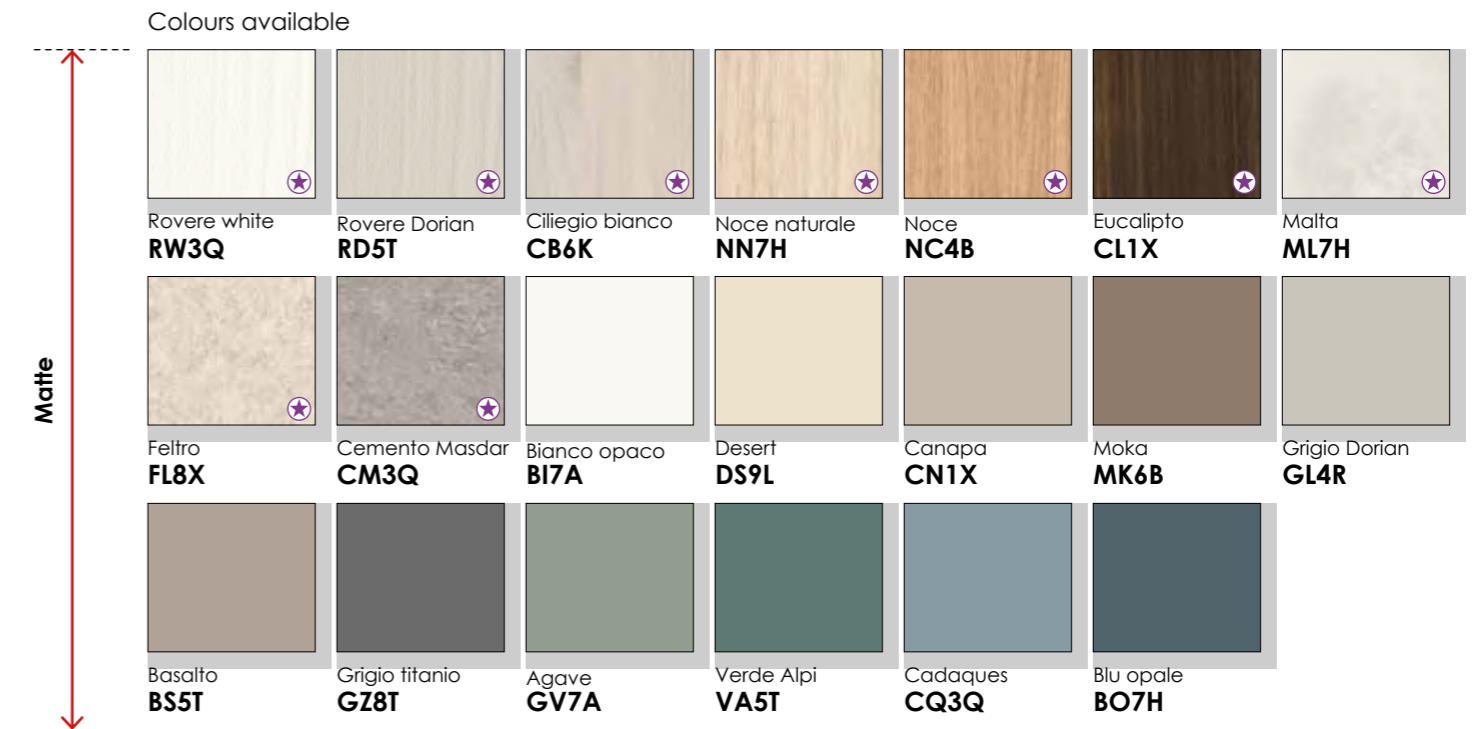

Doors W 45, 50 and 60

- The doors of the over-door wardrobe, of the overhead module, with niche, with console and bottom doors of the TV mount module are without handles and open with a 16 mm protrusion on the vault or on the shelf.
- The upper doors of the seasonal wardrobes can be equipped with a push pull opening. Doors Ht 48/64/80/96 are equipped with 2 hinges. Doors Ht 128 with 3 hinges. Doors Ht 160/192/224 and doors W 45 Ht 240/256 with 4 hinges. Doors Ht 240/256 W 50 and W 60 and doors Ht 288 W 45/50/60 with 6 hinges; corner wardrobes have 165° hinges.
- Lower heights and widths are permitted.

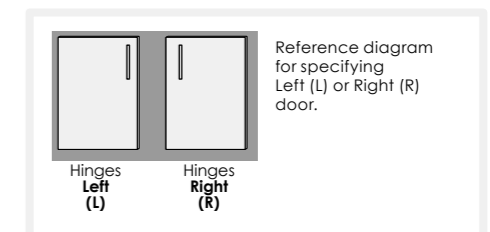

# CUTTING fronts Th 2.5

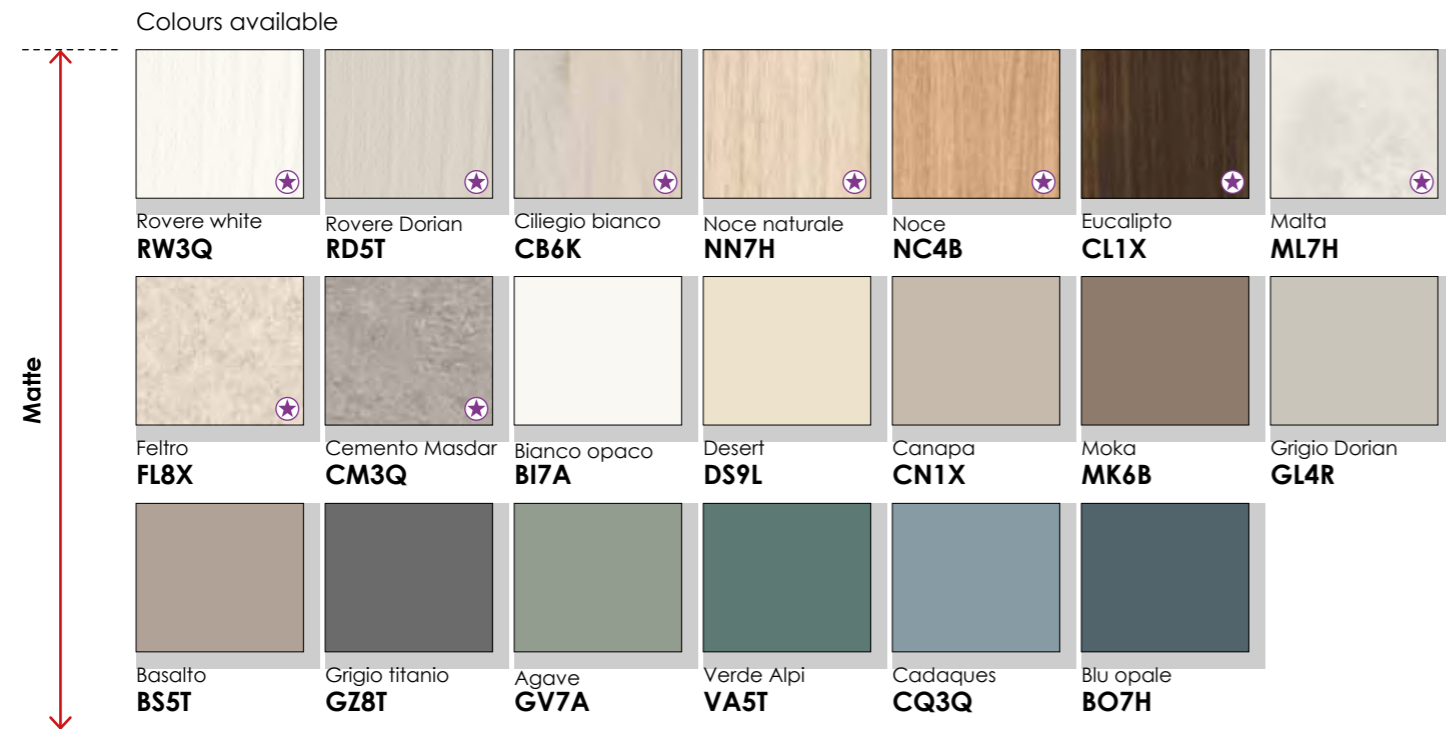

## Groove handle colours

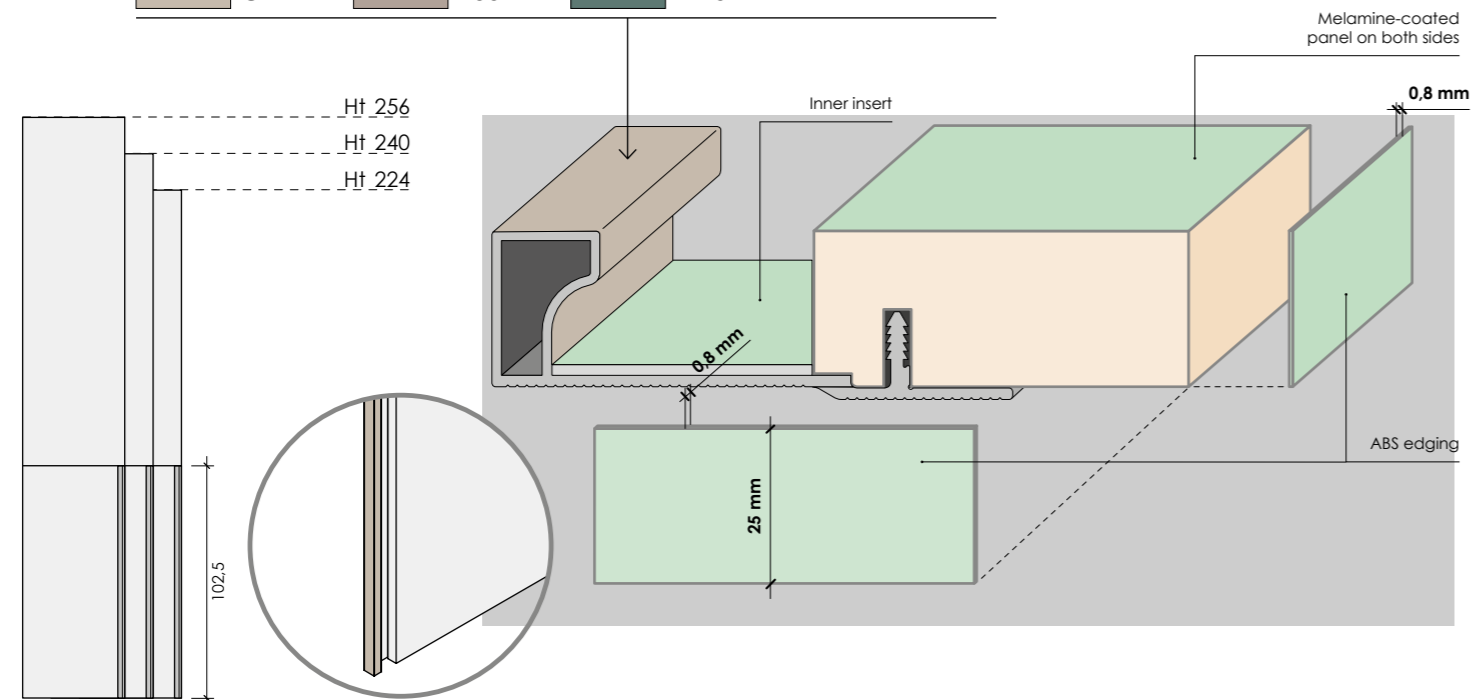

Doors W 45, 50 and 60

- Handle grip in matt lacquered aluminium with matching interior; choice of inner insert in all front colors. If there are two doors, the handle is always positioned on the right-hand door (the left-hand door always consists of a lower and upper square but without handle).
- Each door has 4 adjustable hinges with soft closure, except for doors W 50 / W 60 Ht 240 and Ht 256 which have 6; corner wardrobes have 165° hinges.
- Size reductions are not permitted.
- The individual squares can be customised.

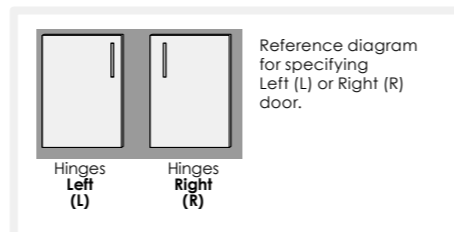

# CUTTING PLUS fronts Th 2.5

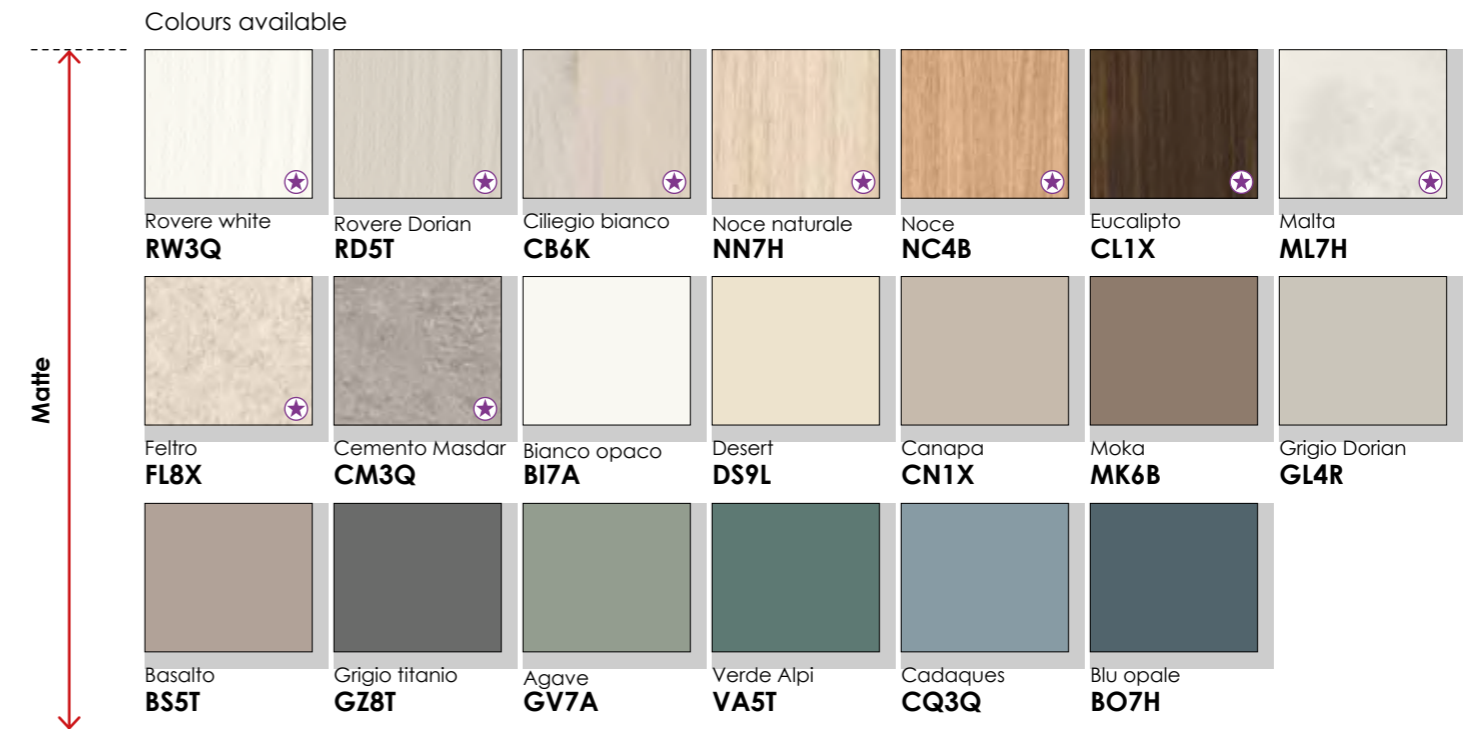

## Groove handle colours

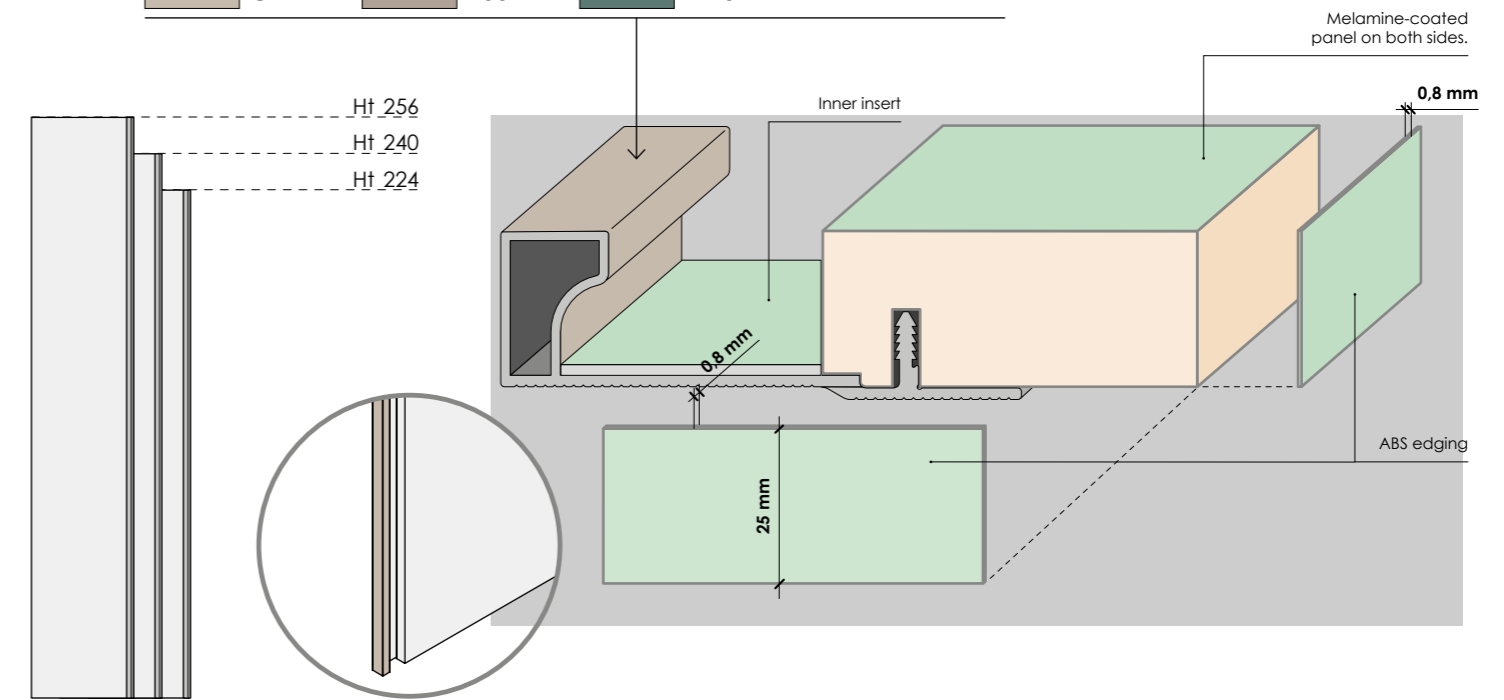
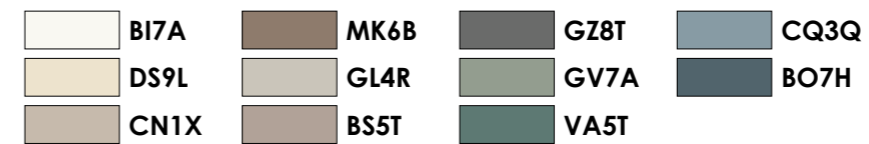

Doors W 45, 50 and 60

- Handle grip in matt lacquered aluminium with matching interior; choice of inner insert in all front colors. If there are two doors, the handle is always positioned on the right-hand door (the left door is smooth without handle).
- Each door has 4 adjustable hinges with soft closure, except for doors W 50 / W 60 Ht 240 and Ht 256 which have 6; corner wardrobes have 165° hinges.
- Lower heights are permitted.

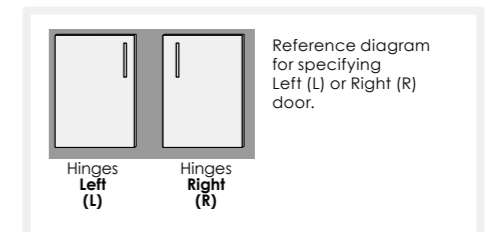

☆ Finishing with textured effect

# WINDOW fronts Th 2.1

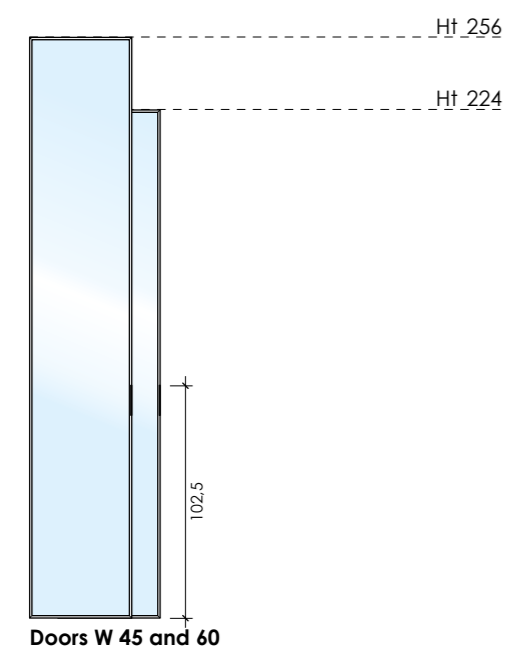

- Fitted with decelerated hinges.
- Size reductions are not permitted.

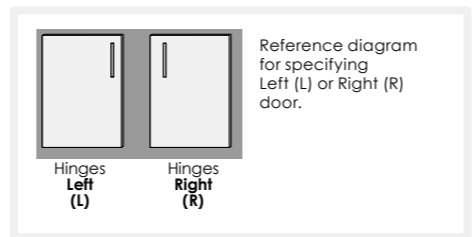
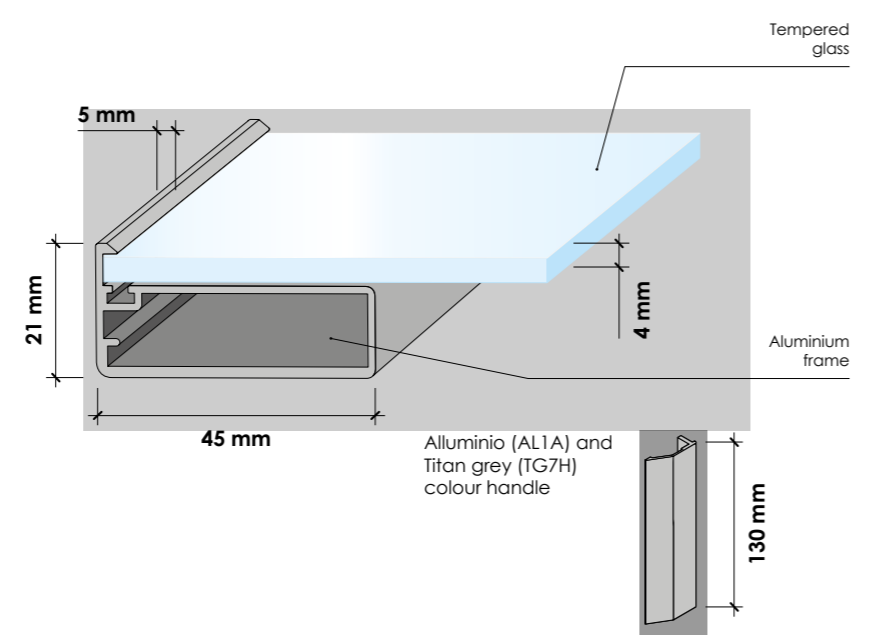

## STYLE sliding doors Th 1.8

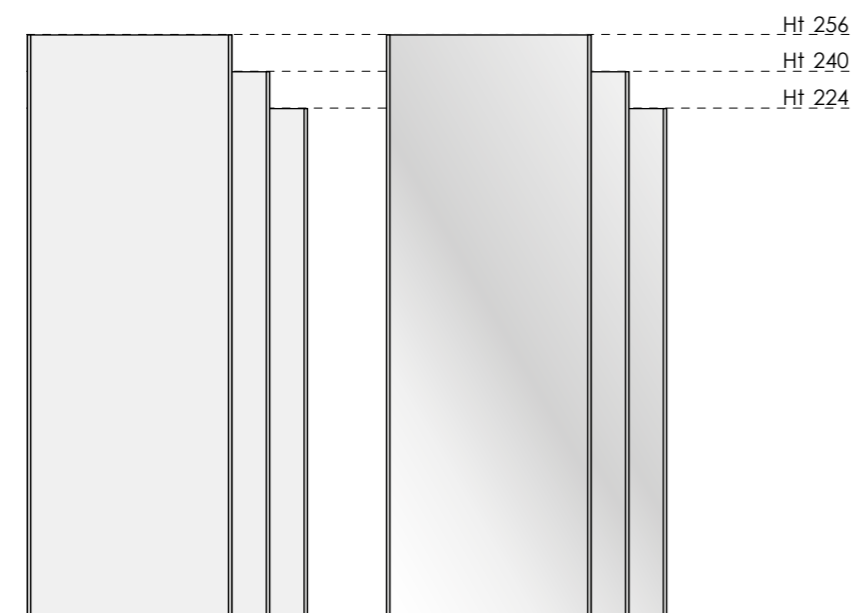
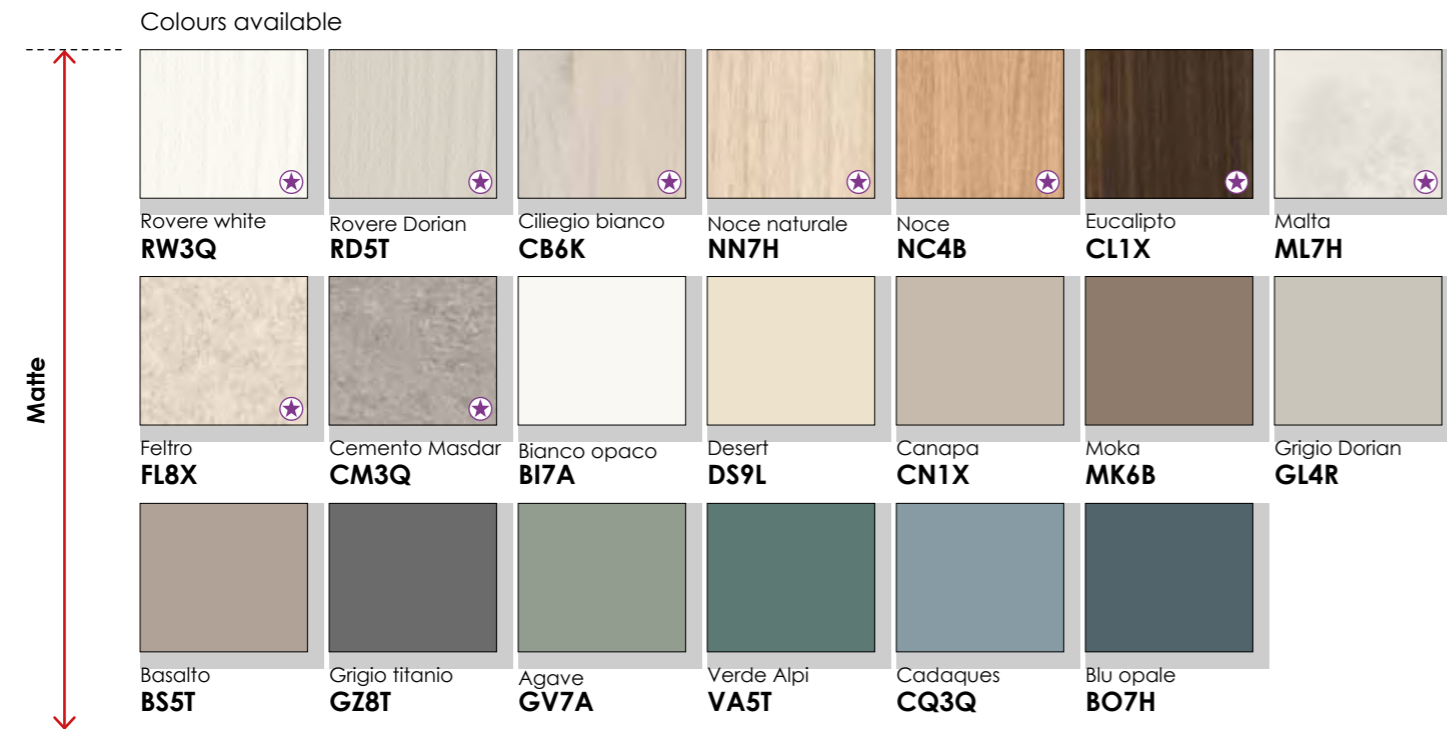

STYLE melamine-coated doors/Mirror doors W 90 and 100

- The Th 0.4 mirror is applied to a Th 1.4 white melamine panel.
- Size reductions are not permitted.

### Long side handle

In anodised aluminium or coated, with integrated adjustment rods and dust protection cover.

Colours available

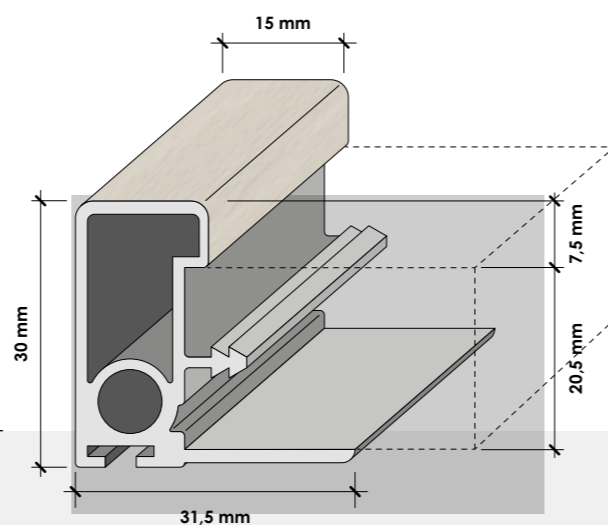
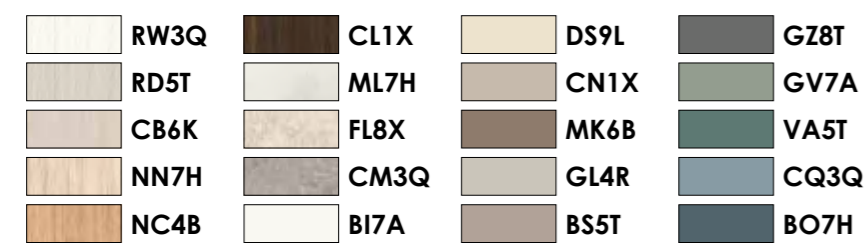

✳ Finishing with textured effect

## MOSAICO sliding doors Th 1.8

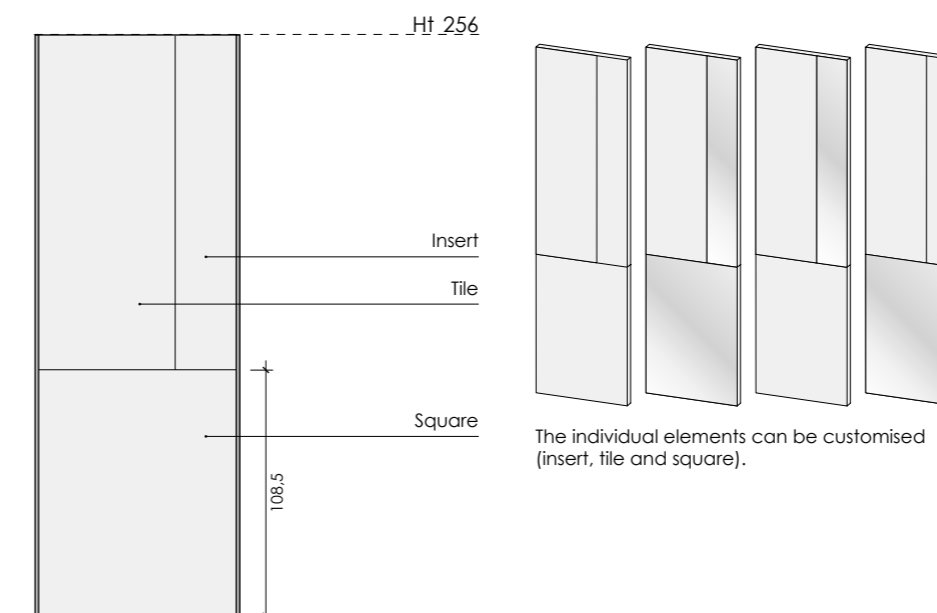
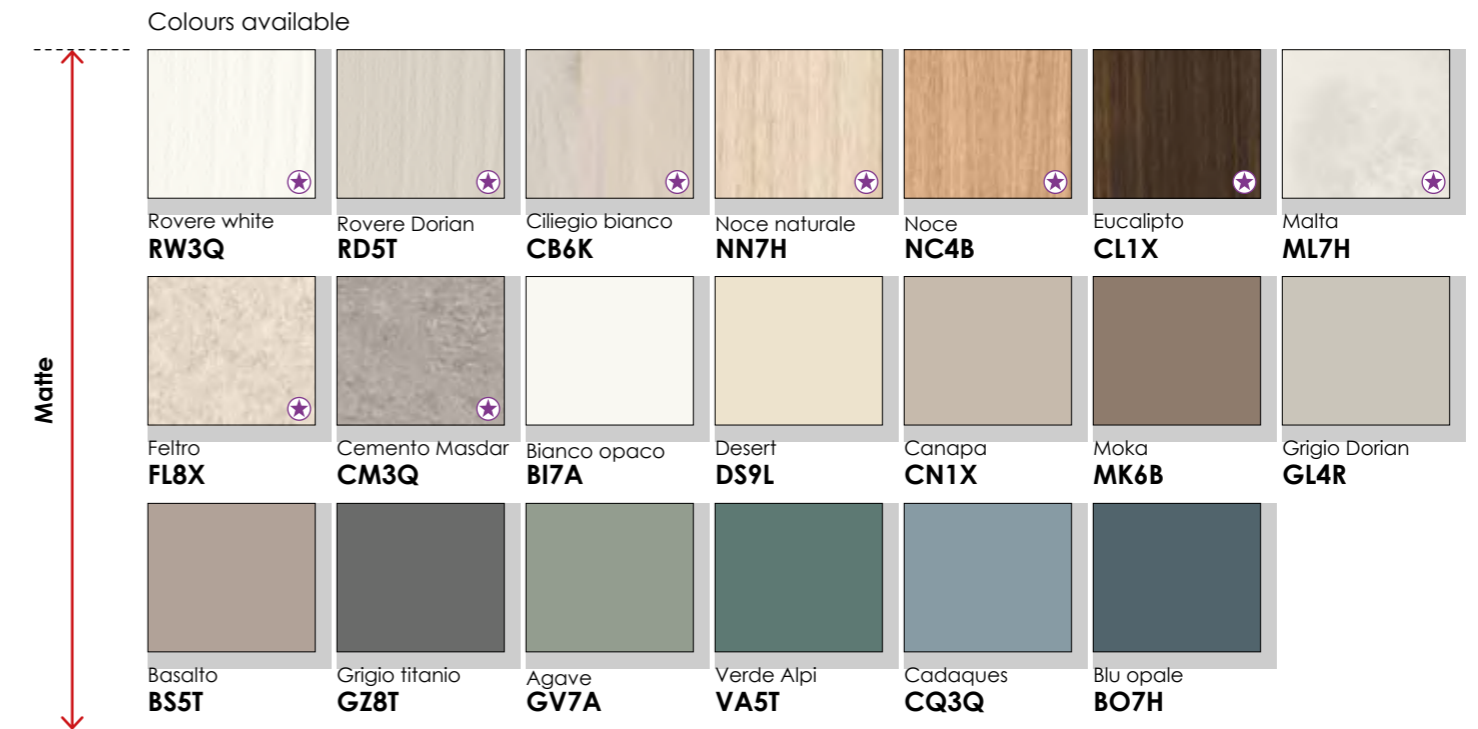

MOSAICO melamine-coated doors/Mirror doors W 90, 100 and 135

- The Th 0.4 mirror is applied to a Th 1.4 white melamine panel.
- Size reductions are not permitted.

### Long side handle

Joining profile and long side handles in anodised aluminium or melamine-faced; with integrated adjustment rods and dust protection cover.

Colours available

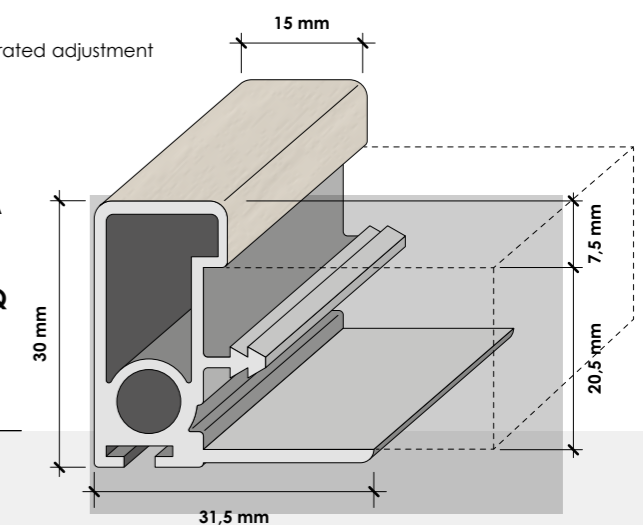
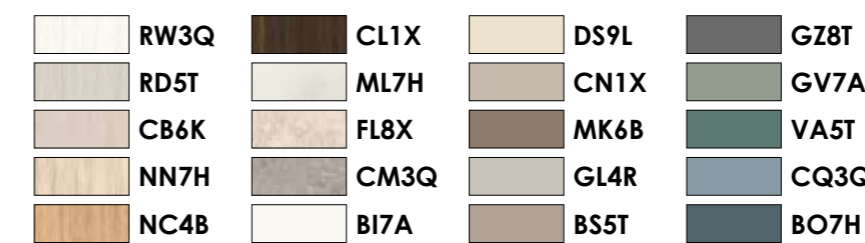

## FREEDOM sliding doors Th 1.8

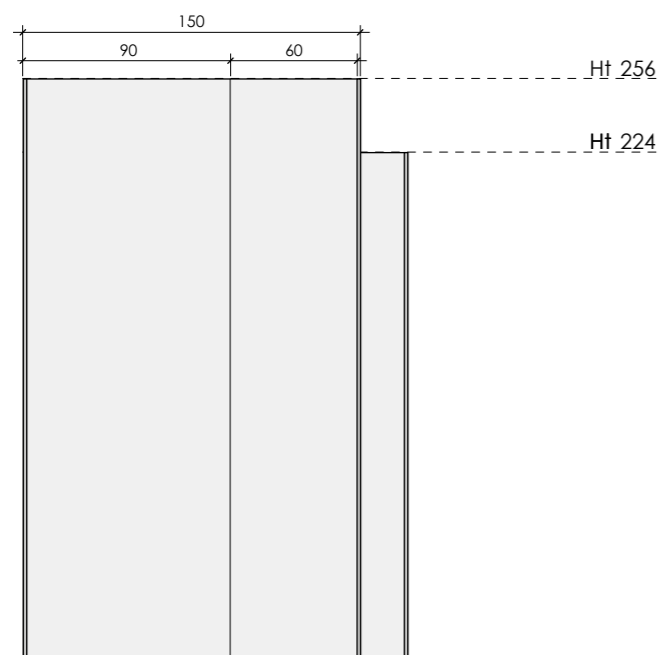
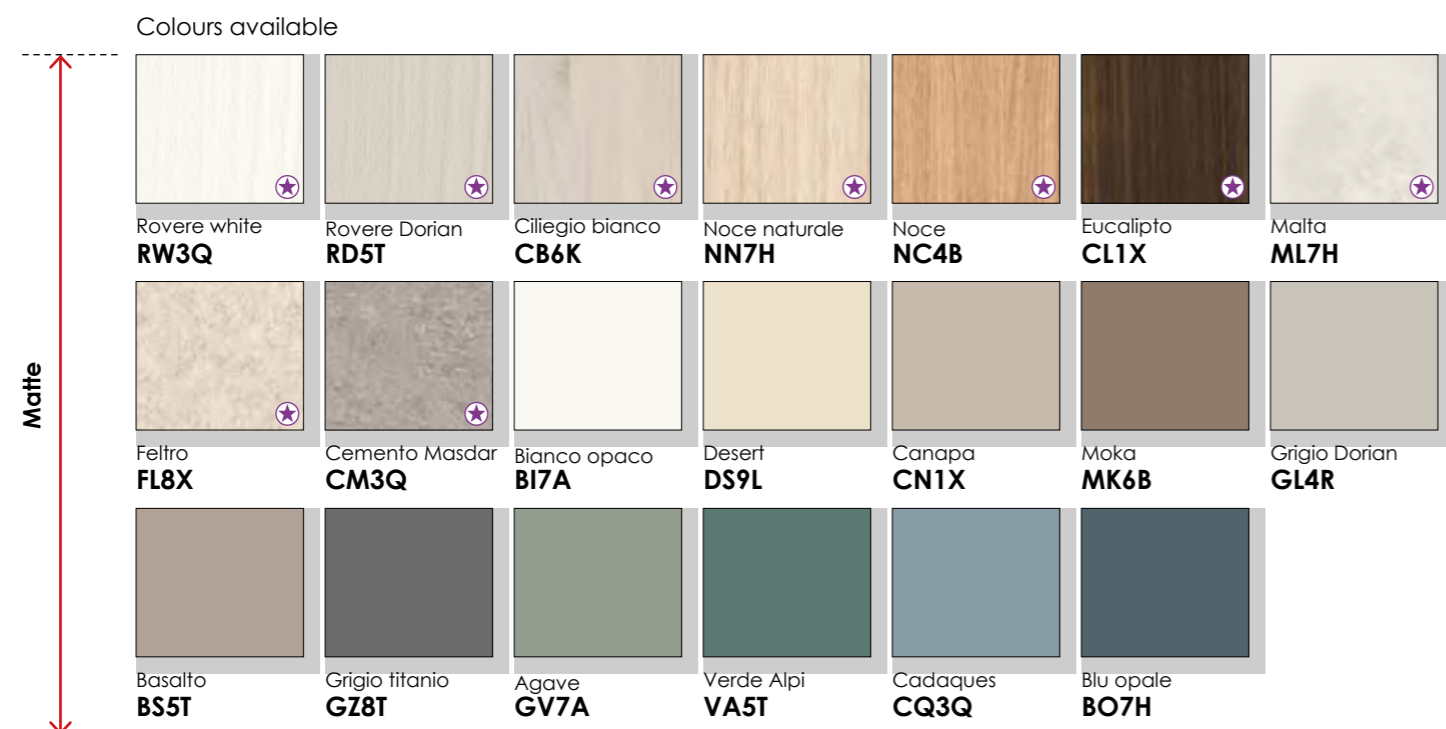

FREEDOM melamine-coated doors W 150

- The positioning of the W 90 / W 60 bands can be established during assembly.
- Size reductions are not permitted.
- The individual bands can be customised.

### Long side handle

In matt lacquered aluminium, with integrated adjustment rods and dust protection cover.

Colours available

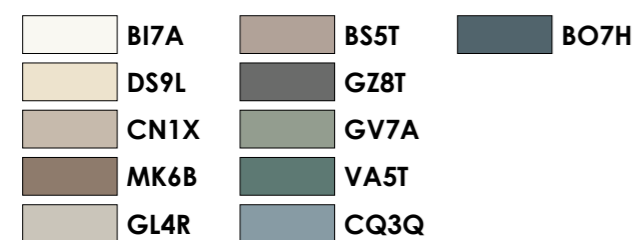

✳ Finishing with textured effect

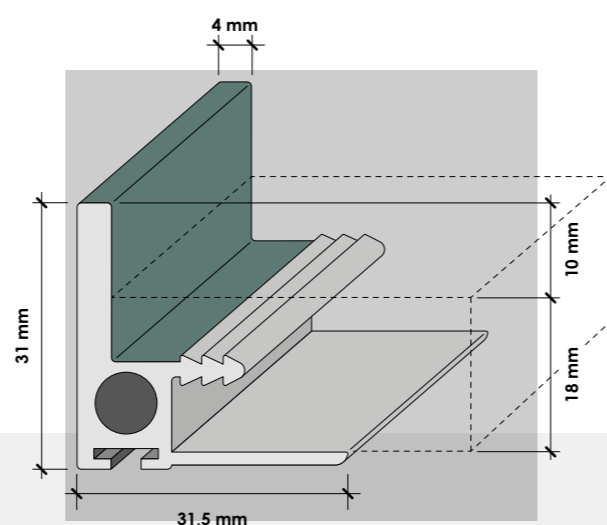

## CONCRETA sliding doors Th 2.5

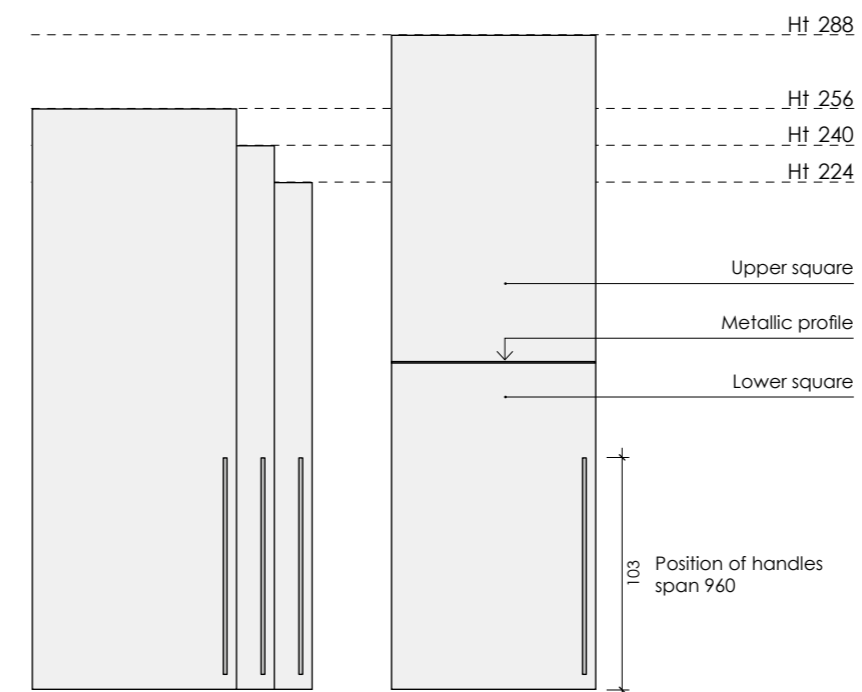
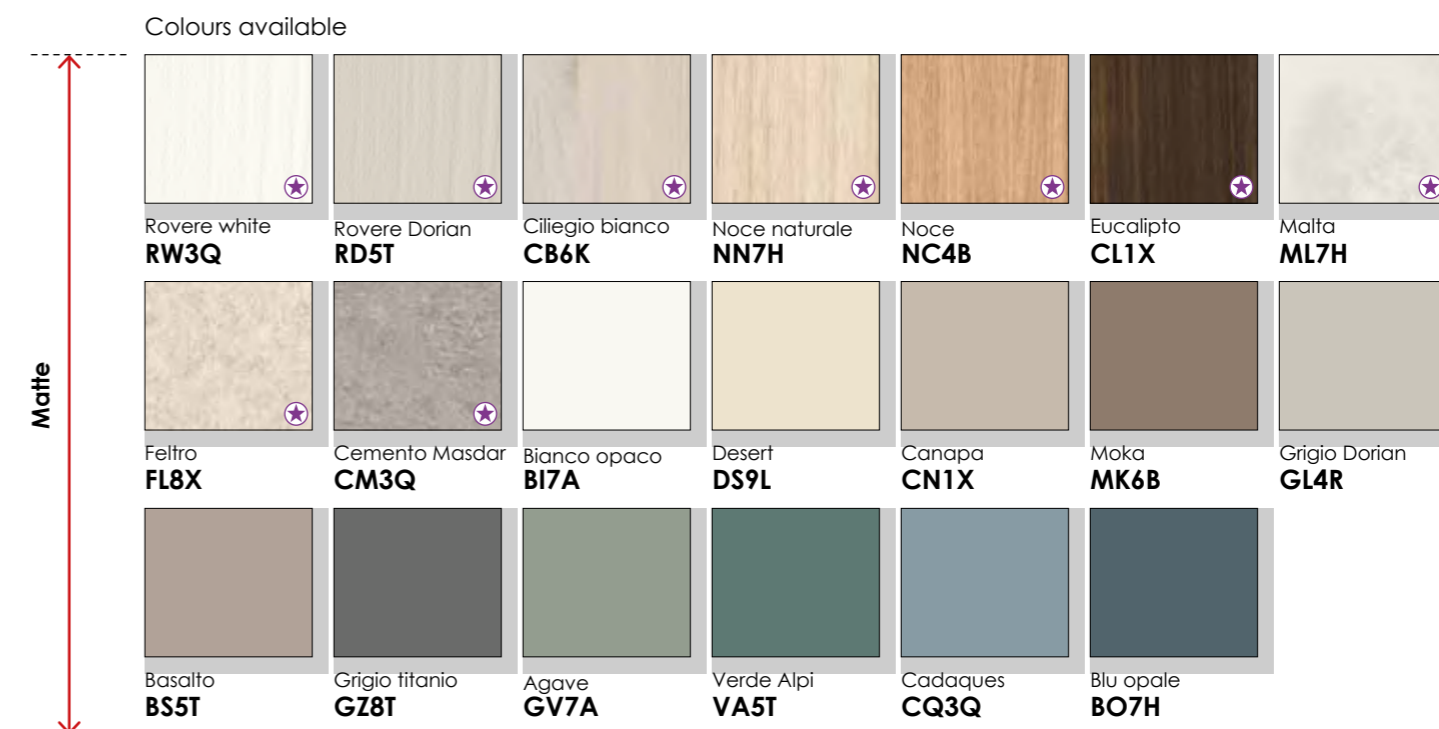

CONCRETA melamine-coated doors W 90 and 100

- The doors H 288 have a metallic profile Th 4 mm, epoxy-powder painted in Carbon grey (CG8X) finish.
- In the doors H 288 the individual squares can be customised.
- Integrated adjustment rods and dust protection cover.
- Lower heights are permitted.

### Available handles

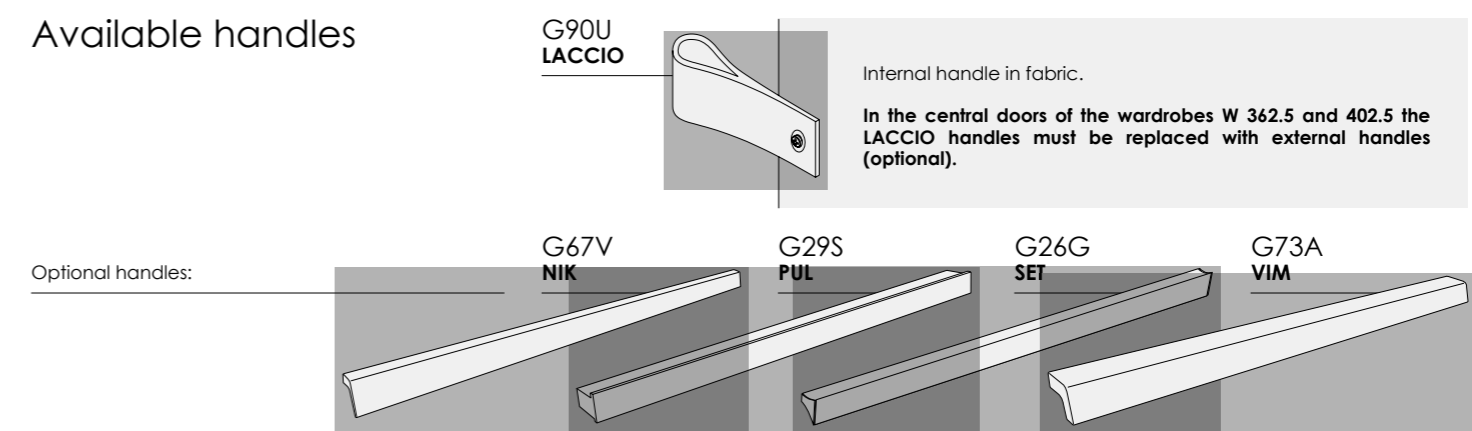



## RAIL sliding doors Th 2.5/1.8

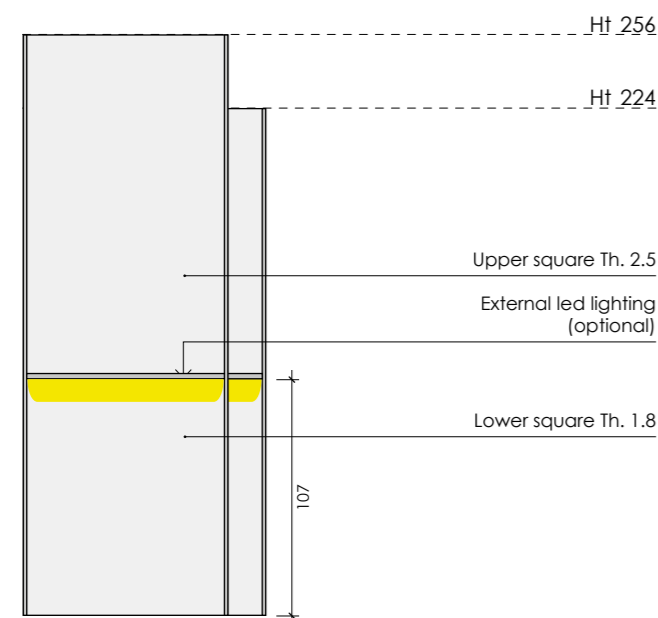
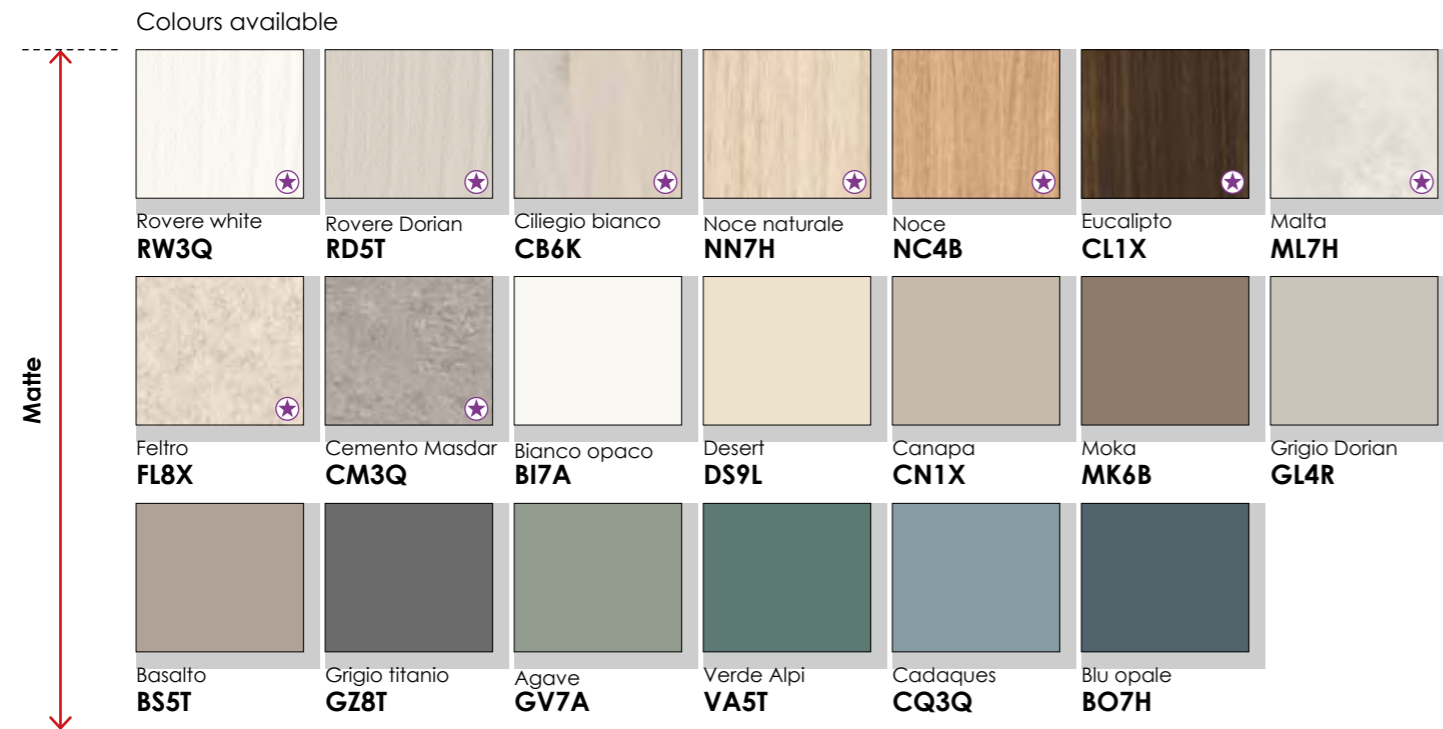

RAIL melamine-coated doors W 90, 100 and 135

- Also available with (optional) horizontal external led lighting (always switched on); power adapter included. For remote control or Bluetooth application vedi pag. 510.
- Size reductions are not permitted.
- The individual squares can be customised.

### Long side handle

Joining profile and long side handles in matt lacquered aluminium, with integrated adjustment rods and dust protection cover.

Colours available

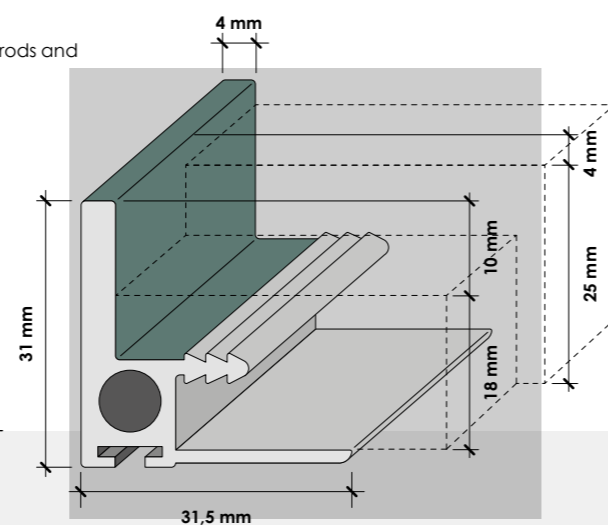

✳ Finishing with textured effect

## CUTTING sliding doors Th 2.5

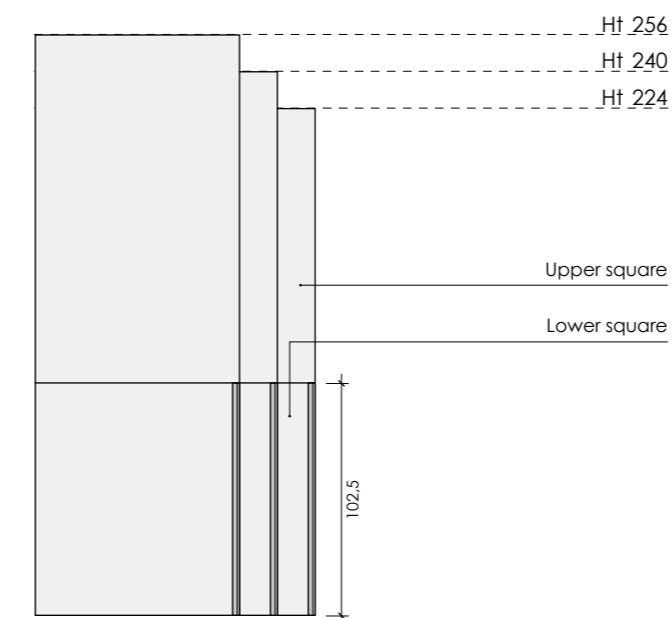
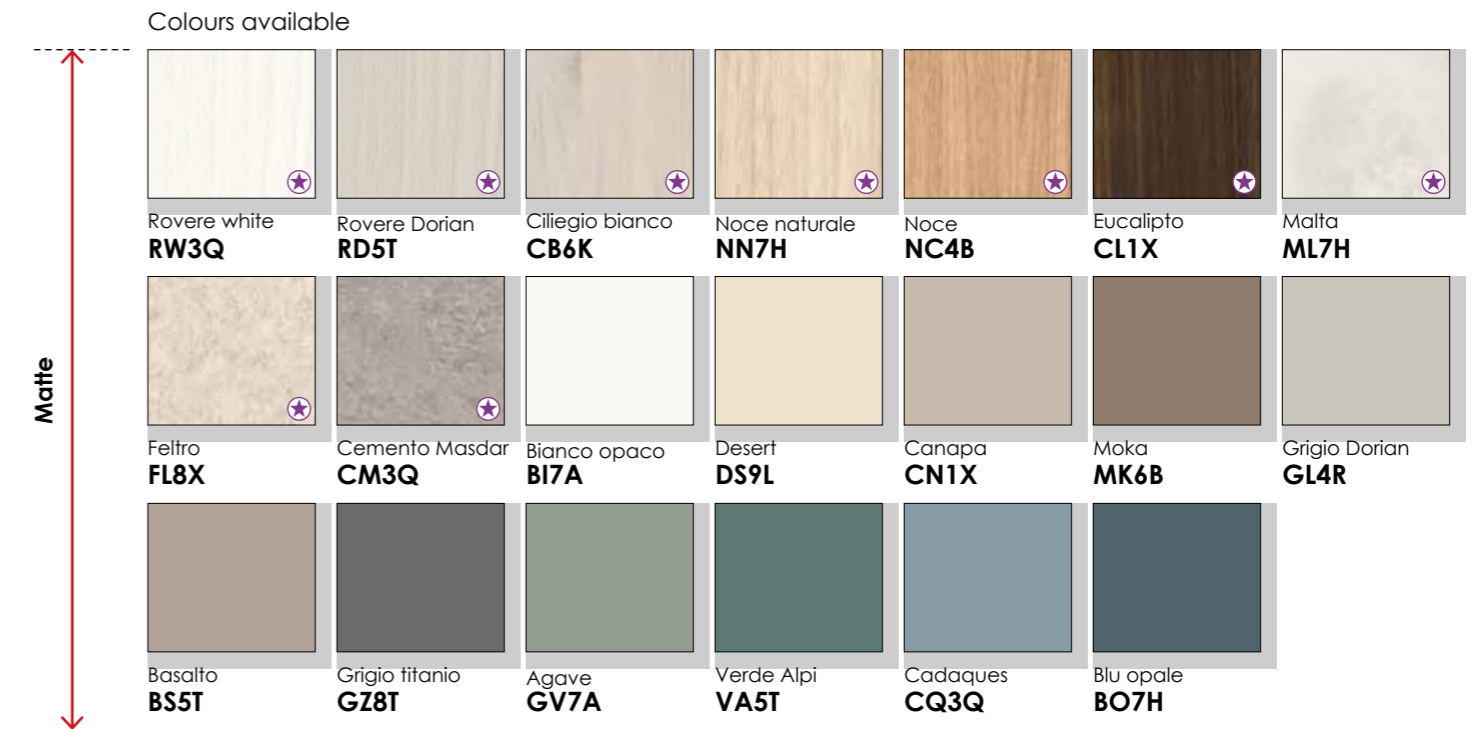

CUTTING melamine-coated doors W 90, 100 and 135

- Integrated adjustment rods and dust protection cover.
- Size reductions are not permitted.
- The individual squares can be customised.

### Groove handle

Handle grip in matt lacquered aluminium with matching interior; choice of inner insert in all front colors.

Colours available

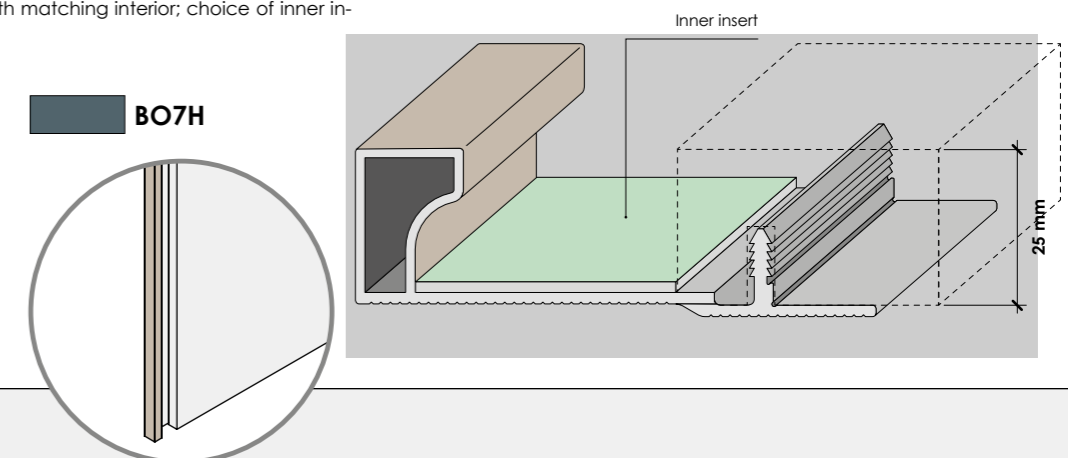
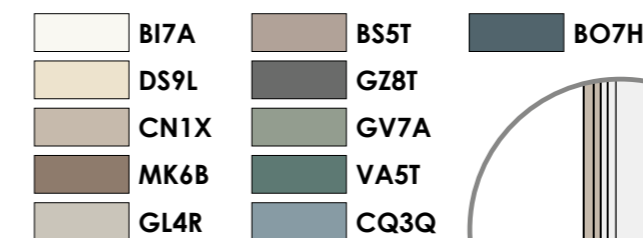

# Handles

## BIS



W mm	Span mm	Code	Code	Loose
192	160	G50F	P99.66X	

Ht mm 9 | Projection mm 20

## BUL



W mm	Span mm	Code	Code	Loose
180	160	G79F	PK00.02V	

Ht mm 9 | Projection mm 22,5

## NIK



W mm	Span mm	Code	Code	Loose
180	160	G63W	P99.91H	
276	256	G65L	P99.92P	
980	960	G67V *	P99.94Z	

Ht mm 25 | Projection mm 18,5

## GIG



W mm	Span mm	Code	Code	Loose
171	160	G19Q	P65.28W	

Ht mm 20 | Projection mm 30

**I** VERTICAL handles

\* In the presence of a pair of doors there is only one handle on the right door

## PUL



W mm	Span mm	Code	Code	Loose
192	160	G28P	P93.27R	
288	256	G45H	P99.72E	
992	960	G29S *	P93.28W	

Ht mm 18 | Projection mm 19

## SET

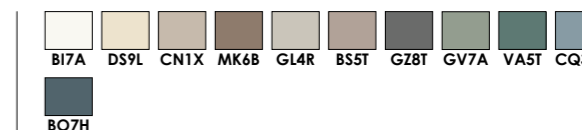

W mm	Span mm	Code	Surcharge	Code	Loose
175	160	G21R		P65.30G	
975	960	G26G *		P65.34D	

Ht mm 29 | Projection mm 20

## VIM



W mm	Span mm	Code	Surcharge	Code	Loose
180	160	G70T		P99.97R	
276	256	G72P		P99.98W	
980	960	G73A *		P99.99B	

Ht mm 24 | Projection mm 30

## INES



Recessed handle, supplied mounted on the door and generates specific processing (recess 18 mm).

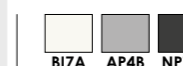

W mm	Span mm	Code	Surcharge	Code	Loose
44	-	G89R *		-	

Ht mm 172 | Projection mm 1,5

<b>AL1A</b> Alluminio	<b>CL1X</b> Eucalipto	<b>GV7A</b> Agave	<b>NP7H</b> Nero opaco
<b>AP4B</b> Acciaio opaco	<b>CM3Q</b> Cemento Masdar	<b>GZ8T</b> Grigio titanio	<b>NR4B</b> Nero spazzolato
<b>B17A</b> Bianco opaco	<b>CN1X</b> Canapa	<b>LM7A</b> Alluminio spazzolato	<b>RD5T</b> Rovere Dorian
<b>BO7H</b> Blu opale	<b>CQ3Q</b> Cadaques	<b>MK6B</b> Moka	<b>RW3Q</b> Rovere white
<b>BS5T</b> Basalto	<b>DS9L</b> Desert	<b>ML7H</b> Malta	<b>VA5T</b> Verde Alpi
<b>CB6K</b> Ciliegio bianco	<b>FL8X</b> Feltro	<b>NC4B</b> Noce	
<b>CH7Y</b> Champagne spazzolato	<b>GL4R</b> Grigio Dorian	<b>NN7H</b> Noce naturale	

# Handle positions

Handles in vertical position. The upper doors can be equipped with push pull (without surcharge).

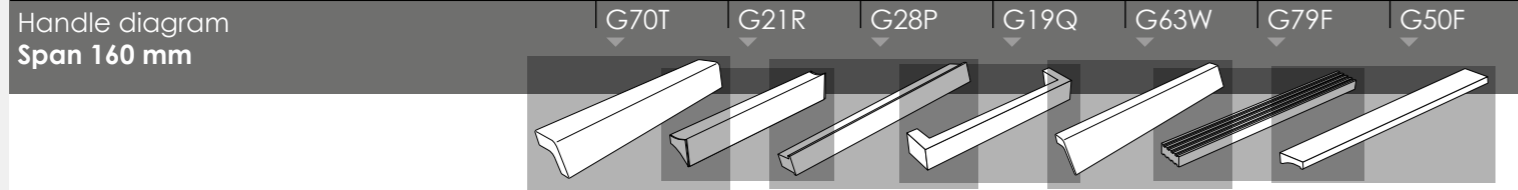

Doors  
W 45/50/60

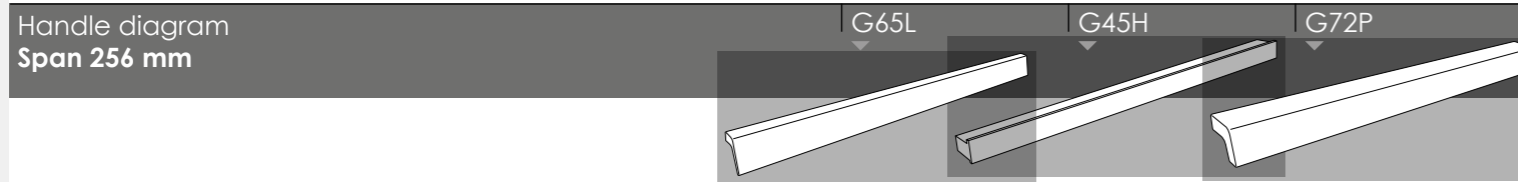
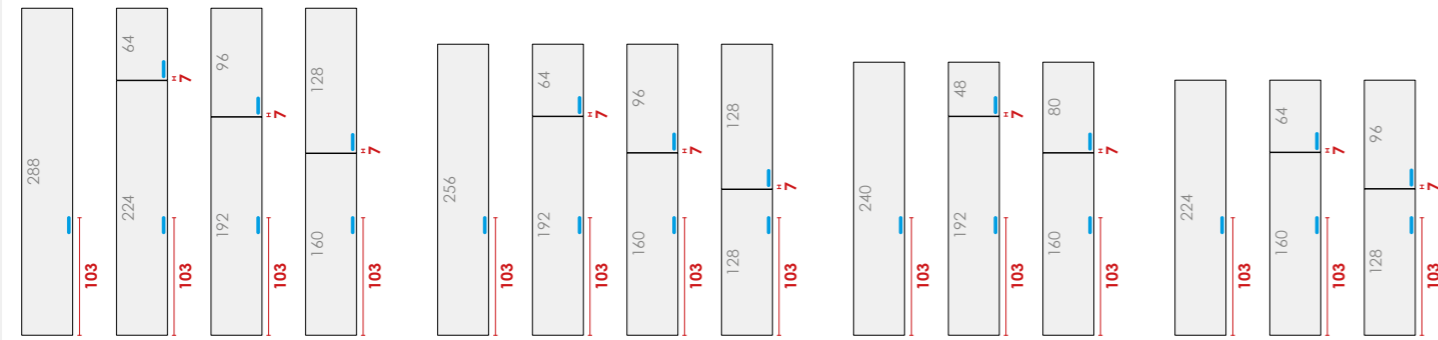

Doors  
W 45/50/60

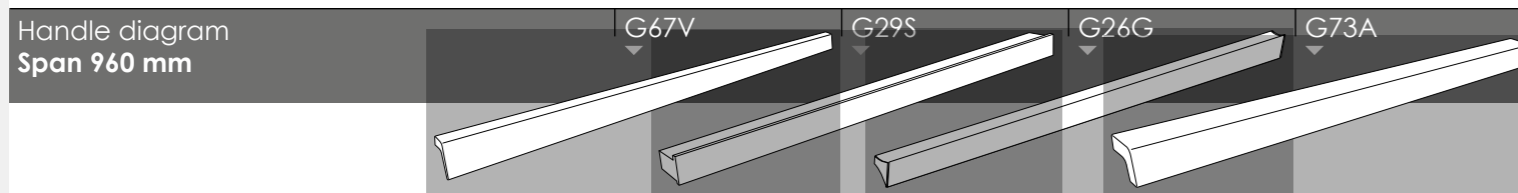
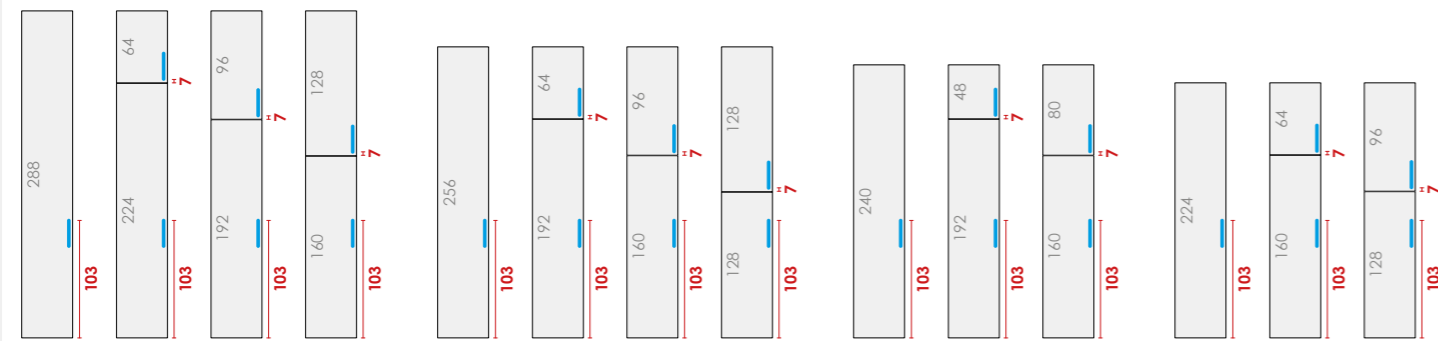

Doors  
W 45/50/60

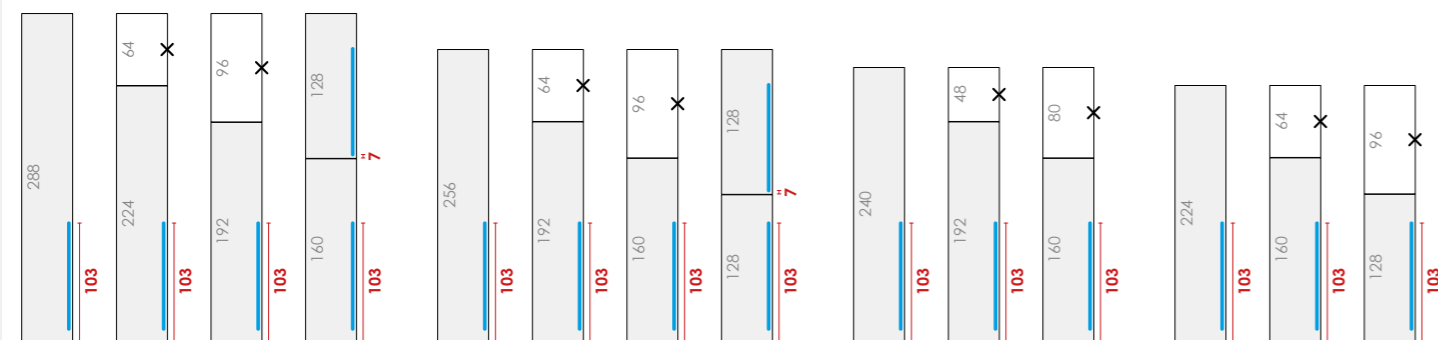

X Handles cannot be fitted.



Doors  
W 45/50/60

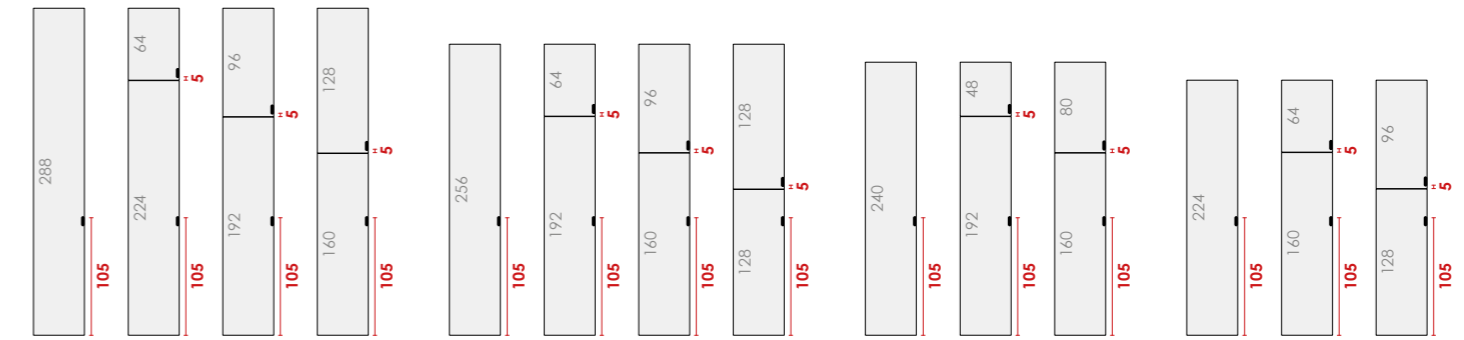

# Hinged doors

## Ht 224

Specify hinge  
R or L

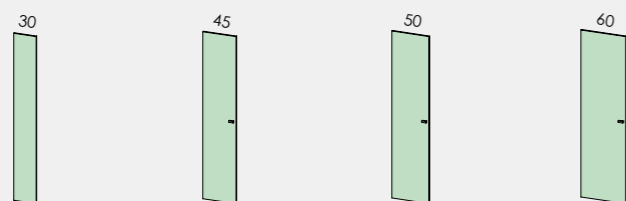

Code	PV00.00D	PV00.01L	PV00.02S	PV00.03Y		
STYLE	Th 1.8					
	matte					
	glossy					
CONCRETA	Th 2.5					
CUTTING	Th 2.5					
CUTTING PLUS	Th 2.5					
WINDOW	Th 2.1					

## Ht 240

Specify hinge  
R or L

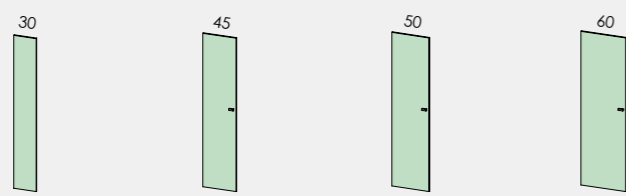

Code	PV00.04E	PV00.05M	PV00.06T	PV00.07Z		
STYLE	Th 1.8					
	matte					
	glossy					
CONCRETA	Th 2.5					
CUTTING	Th 2.5					
CUTTING PLUS	Th 2.5					
WINDOW	Th 2.1					

## Ht 256

Specify hinge  
R or L

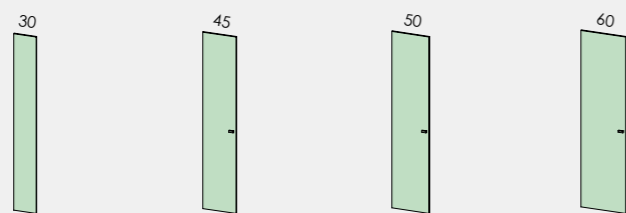

Code	PV00.08F	PV00.09N	PV00.10K	PV00.11R		
STYLE	Th 1.8					
	matte					
	glossy					
CONCRETA	Th 2.5					
CUTTING	Th 2.5					
CUTTING PLUS	Th 2.5					
WINDOW	Th 2.1					

## Ht 288

Specify hinge  
R or L

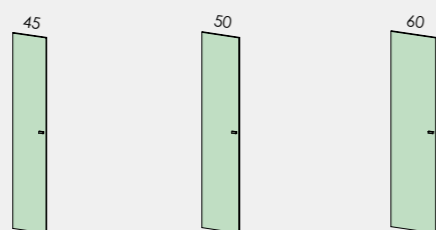

Code		PV00.12X	PV00.13D	PV00.14L		
CONCRETA	Th 2.5					

Components in **Types and colors FRONT**

## Ht 48

Specify hinge  
R or L



Code	PV00.20Q	PV00.21W	PV00.22C		
CONCRETA	Th 2.5				

## Ht 64

Specify hinge  
R or L

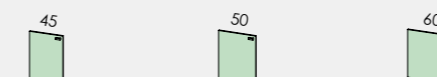

Code	PV00.23K	PV00.24R	PV00.25X		
CONCRETA	Th 2.5				

## Ht 80

Specify hinge  
R or L

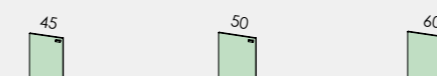

Code	PV00.26D	PV00.27L	PV00.28S		
CONCRETA	Th 2.5				

## Ht 69

Specify hinge  
R or L

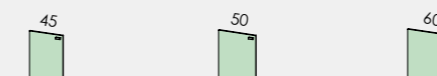

Code	PV00.29Y	PV00.30V	PV00.31B		
CONCRETA	Th 2.5				

## Ht 128

Specify hinge  
R or L

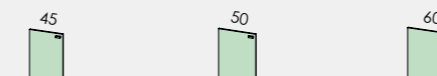

Code	PV00.32H	PV00.33Q	PV00.34W		
CONCRETA	Th 2.5				

## Ht 160

Specify hinge  
R or L



Code	PV00.35C	PV00.36K	PV00.37R		
CONCRETA	Th 2.5				

## Ht 192

Specify hinge  
R or L

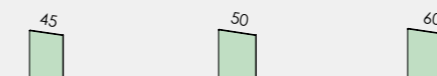

Code	PV00.38X	PV00.39D	PV00.40A		
CONCRETA	Th 2.5				

# Custom cuts

35,00 cost of cutting each component of the element.  
113,00 cost for CONCRETA sliding door cut.

Cuts are carried out only on request with explanatory drawing.  
It is not possible to create two-sided elements.

For customised cuts of units that are not specified, consult the technical notes inserted in the various sections.

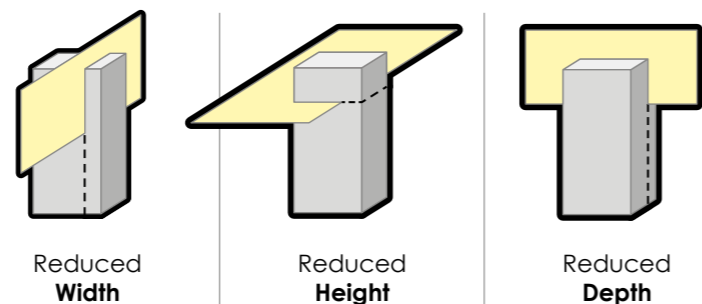

	Reduced Width	Reduced Height	Reduced Depth
STYLE doors	●	●	○
CONCRETA doors	●	●	○
CUTTING doors	●	●	○
CUTTING PLUS doors	●	●	○
WINDOW doors	●	●	○
STYLE sliding doors	●	●	○
MOSAICO sliding doors	●	●	○
FREEDOM sliding doors	●	●	○
CONCRETA sliding doors	●	● * <sub>1</sub>	○
RAIL sliding doors	●	●	○
CUTTING sliding doors	●	●	○
Hinged door wardrobe modules structures	●	●	●
Corner modules structures	●	●	●
End modules structures	●	●	●
Overhead wardrobes	●	●	●
Wardrobes with niche	●	●	●
Wardrobes with console	●	●	●
Wardrobes with TV mount	●	●	●
Sliding door wardrobe structures	●	●	●
Walk-in wardrobes modules structures	●	●	●
Internal partitions	●	●	●
Metal and glass parts	●	●	●

● Processing executable  
● Processing not executable

\*<sub>1</sub> Not on doors Ht 288

## Reduced Width

**Example with a hinged door wardrobe:**  
To reduce the width of a one-door wardrobe, 5 components have to be cut (bottom panel, top, shelf, back panel and door); therefore, the cost of this process is:

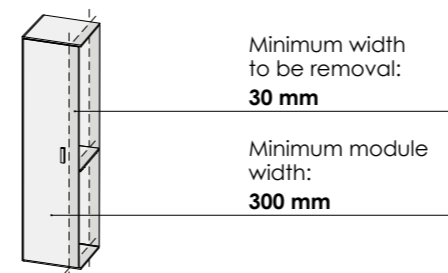

## Reduced Height

**Cuts are always made at the top**

**Example with a hinged door wardrobe:**  
To reduce the height of a one-door wardrobe, 3 components have to be cut (back, side and door); therefore the cost of this operation is:

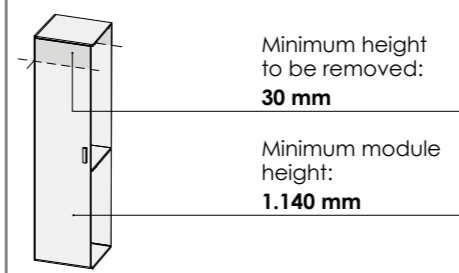

**Example with sliding door wardrobe:**  
To reduce the height of a 2 doors wardrobe, 7 components have to be cut (3 sides, 2 backs and 2 doors); therefore the cost of this operation is:

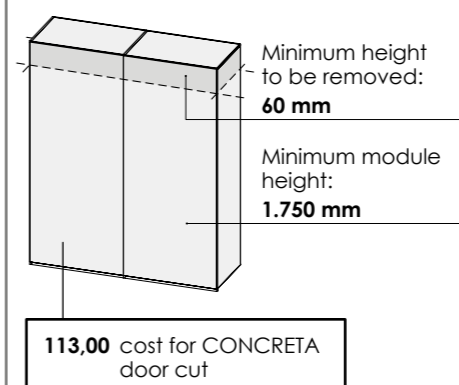

## Reduced Depth

**Must be fixed to the wall**

**Example with a hinged door wardrobe:**  
To reduce the depth of a wardrobe, 4 components have to be cut (bottom panel, top panel, shelf and side panel); therefore the cost for processing amounts to:

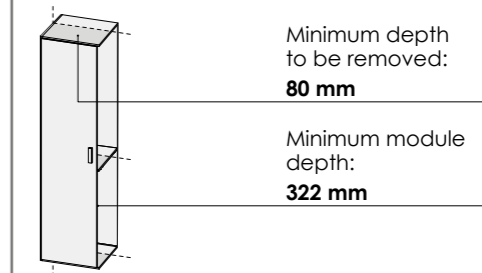

**Example with sliding door wardrobe:**  
To reduce the depth of a 2 doors wardrobe, 9 components have to be cut (2 bottoms, 2 top panels, 2 shelves, and 3 sides); therefore, the cost of this process is:

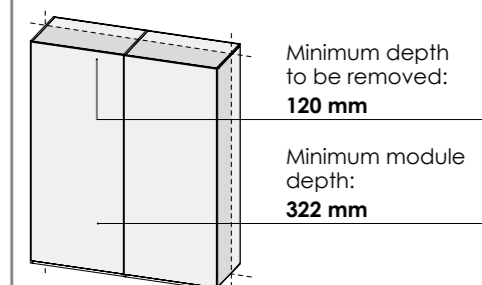

## Reduction in the depth of a central element

**Example:**  
To reduce the depth of central module, 3 components (bottom, top and shelf) are cut; the cost of this modification is:

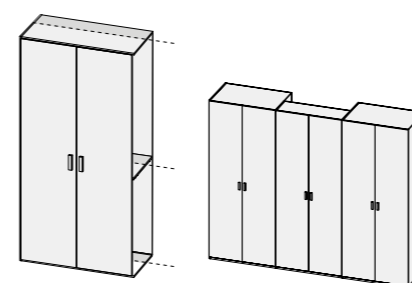

## Reduction in the depth of an end element

**Example:**  
To reduce the depth of an end module in the wardrobe, 4 components (bottom, top, shelf and side) are cut; the cost of this modification is:

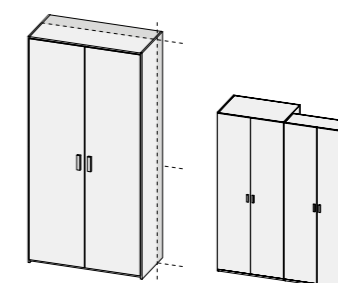

# Filler strips for modular wardrobes

# Hardware

	Vertical (vertical vein) for hinged door and sliding door	Vertical with overlap (vertical vein) for hinged door	Horizontal (horizontal vein) for hinged door
<b>Code</b>	<b>PV00.41G</b>	<b>PV00.42P</b>	<b>PV00.43V</b>
matte			
glossy			
	<p>Side panel Wall Compensation profile from 6 to 20 mm Door</p> <p>Minimum height: <b>1.140 mm</b> Maximum height: <b>2.893 mm</b> Minimum width: <b>80 mm</b> Maximum width: <b>300 mm</b> <b>+ 20 mm</b> (compensator profile)</p>	<p>Side panel Wall Compensation profile from 6 to 20 mm Door</p> <p>Minimum height: <b>1.140 mm</b> Maximum height: <b>2.893 mm</b> Minimum width: <b>80 mm</b> Maximum width: <b>300 mm</b> <b>+ 20 mm</b> (compensator profile)</p>	<p>Ceiling 1 cm Compensation profile from 6 to 20 mm Door</p> <p>Minimum height: <b>80 mm</b> Maximum height: <b>200 mm</b> Minimum width: <b>300 mm</b> Maximum width: <b>3.000 mm</b> <b>+ 20 mm</b> (compensator profile)</p>

	Vertical (vertical vein) for hinged door
<b>Code</b>	<b>PV00.44B</b>
matte	270,00
glossy	433,00
	<p>Kit consisting of openable door with 165° hinge and panel stop. Generates specific holes for hinges on the wardrobe side panel. The door is equipped with a handle and/or push-pull opening.</p> <p>Side panel Wall Panel stop 165° hinge opening 1,8/2,5 cm Openable door</p> <p>Variable height depending on the wardrobe next to which it is placed. Maximum height: <b>2.556 mm</b> Minimum width: <b>120 mm</b> Maximum width: <b>597 mm</b></p>

Components in **GROUP 3 colors**

## Hinges with base plate

(4 pieces)

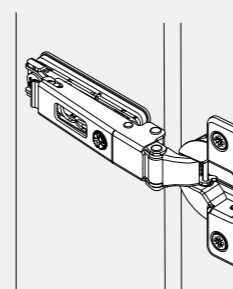

Code	For use on:
<b>PV00.52U</b>	Hinged doors for wardrobes Th 1.8 and WINDOW doors
<b>PV00.56V</b>	Hinged doors for end wardrobes Th 1.8
<b>PV00.50F</b>	Hinged doors for corner wardrobes Th 1.8
<b>PV00.53A</b>	Hinged doors for wardrobes Th 2.5
<b>PV00.57B</b>	Hinged doors for end wardrobes Th 2.5
<b>PV00.51N</b>	Hinged doors for corner wardrobes Th 2.5
<b>PV00.54G</b>	Hinged doors for closet Th 1.8
<b>PV00.55P</b>	Hinged doors for closet Th 2.5

Decelerated

Code	PV00.58H			

### Kit for assembly in niche

Special pins and spanners kit for wardrobe assembly in niche; 2 cm in height and width is sufficient for assembly.

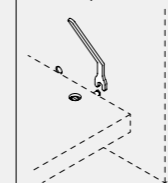



# Accessories for modular wardrobes

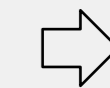

For compartment W:	Movable shelf for wardrobe		Movable shelf for wardrobe		Movable shelf for seasonal wardrobe		PLUS clothes hanging bar		Surcharge for top panel with led profile	
	Dpt 50,8 Th 3,5	With led profile	Dpt 50,8 Th 3,6	With led profile	Dpt 57,6 Th 3,5	Used standard as stop shelves between doors, in seasonal wardrobes.	Ø 2,8	Dpt 1,5 Th 0,6	Led profile exclusively for application to wardrobe top. Generates specific holes.	
	<b>Code</b>	<b>Code</b>	<b>Watt</b>	<b>Code</b>	<b>Code</b>	<b>Code</b>	<b>Code</b>	<b>Code</b>	<b>Code</b>	<b>Watt</b>
30	PV20.50N	PV21.10V	2	PV20.51U	-	-	PV20.52A	PV00.80X	-	2
45	PV20.53G	PV21.11B	4	PV20.54P	PV21.00Q	4	PV20.55V	PV00.81D	-	4
50	PV20.56B	PV21.12H	4	PV20.57H	PV21.01W	4	PV20.58Q	PV00.82L	-	4
60	PV20.59W	PV21.13Q	5	PV20.60T	PV21.02C	5	PV20.61Z	PV00.83S	-	5
70	PV20.62F	PV21.14W	6	-	-	-	PV20.63N	PV00.84Y	-	6
90	PV20.64U	PV21.15C	8	PV20.65A	PV21.03K	8	PV20.66G	PV00.85E	-	8
100	PV20.67P	PV21.16K	9	PV20.68V	PV21.04R	9	PV20.69B	PV00.86M	-	9
120	PV20.70Y	PV21.17R	11	PV20.71E	PV21.05X	11	PV20.72M	PV00.87T	-	11
135	PV20.73T	PV21.18X	13	-	-	-	PV20.74Z	PV00.88Z	-	13

Movable shelf for corner wardrobe		Movable shelf for corner wardrobe		PLUS clothes hanging bars for corner		Surcharge for top panel with led profile		
Dpt 50,8 Th 3,5	For corner with universal gap	With led profile positioned on long shelf side.	Dpt 50,8 Th 3,6	With led profile positioned on long shelf side.	Ø 2,8	Dpt 1,5 Th 0,6	Led profile exclusively for application to long top side. Generates specific holes.	
<b>Code</b>	<b>Code</b>	<b>Code</b>	<b>Code</b>	<b>Code</b>	<b>Code</b>	<b>Code</b>	<b>Code</b>	<b>Watt</b>
PV20.32Q	PV20.34C	PV21.20A	PV20.33W	PV20.30B	PV21.22r	PV00.91K	PV00.94D	9

Movable shelf for closet 2 doors		Movable shelf for closet 1 door		PLUS clothes hanging bar for closet 2 doors		PLUS clothes hanging bar for closet 1 door		Movable shelf for end unit	
Indicate L or R Dpt 50,8 Th 3,6	For closet with universal gap	Indicate L or R Dpt 50,8 Th 3,6	For closet with universal gap	Ø 2,8	For closet with universal gap	Ø 2,8	For closet with universal gap	Dpt 50,8 Th 3,5	
<b>Code</b>	<b>Code</b>	<b>Code</b>	<b>Code</b>	<b>Code</b>	<b>Code</b>	<b>Code</b>	<b>Code</b>	<b>Code</b>	
PV20.40G	PV20.42V	PV20.41P	PV20.43B	PV00.89F	PV00.93X	PV00.90C	PV00.92R	PV20.81L PV20.80D	

Cantilever clothes rail		Cantilever clothes rail		Metal clothes reacher pole		Inside mirror for door W 45/60		Full pull-out 180° swivel mirror		Multipurpose compartment	
Ht 84 Kg 10	90 - 100 - 120	Ht 88 Kg 10	Clothes riser with soft rise and descent. Carbon grey (CG8X) finishing.	Ht 88 ÷ 159 Extendable.	Ht 147 W 32	Ht 115 W 45	For wardrobes with sliding doors (to fit on side).	Ht 34,6 W 87 Dpt 24,5	Positionable on top of standard shelves.		
<b>Code</b>	<b>Code</b>	<b>Code</b>	<b>Code</b>	<b>Code</b>	<b>Code</b>	<b>Code</b>	<b>Code</b>	<b>Code</b>	<b>Code</b>		
PV00.73M	PV00.74T	PV00.95L	PV00.75Z	PV00.76F	PV20.12D						

Components in **CARCASE** colors



Included: the led profile already applied to the top/shelf, the modification for the cable passage, and 2 metres of cable for connection to the power adapter. **To be completed with power adapter(s) as indicated in "Power adapters and switches".**

Elements equipped with side cross-pieces for fixing to the central aluminium frame side; codes also to be used when the elements are to be positioned between one aluminium frame side and one panel side. In order to use these elements, our graphic software must be used, equipping the accessory inside the relative carcass.

# Accessories for modular wardrobes

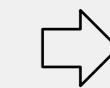

	<b>Pull-out shoe rack</b> Ht 17,2 * Including coin tray Dpt 46,5	<b>Metal pull-out basket</b> Ht 12,4 * Including coin tray Dpt 46,5	<b>Pull-out pant rack</b> Ht 8 Complete with 10 trouser rails Dpt 46,5	<b>Pull-out tie/belt rack + pant rack</b> Ht 8 Complete with 4 trouser rails Dpt 46,5	<b>2 pull-out fabric laundry baskets</b> Ht 41,5 * Including coin tray Dpt 46,5	<b>Tie rack hooks</b> W 42 ⚡ Can be inserted where the icon is shown	<b>Coin tray</b> W 42 ⚡ Can be inserted where the icon is shown	Example of pant rack with tie rack hooks and coin tray.
<b>90</b>	<b>PV00.72E</b>	<b>PV00.98E</b>	<b>PV00.70S</b>	<b>PV00.68P</b>	<b>PV00.66A</b>	<b>Code P07.12C</b>	<b>Code P07.13H</b>	
<b>100</b>	<b>PV00.71Y</b> *	<b>PV00.97Y</b> *	<b>PV00.69V</b>	<b>PV00.67G</b>	<b>PV00.65U</b> *			

	<b>Inclined shoe rack</b> Dpt 50,8 Th 3,5	<b>With led profile</b> ⚡	<b>Accessorised shelf</b> Can be positioned on single shelf or top for compartment Ht 3,5 Dpt 50,8						
For compartment <b>W</b> :	<b>Code</b>	<b>Code</b>	<b>Watt</b>	<b>Code</b>	<b>Code</b>				
<b>60</b>	<b>PV20.90K</b>	<b>PV20.94L</b>	5	-	-				
<b>90</b>	<b>PV20.91R</b>	<b>PV20.95S</b>	8	<b>PV20.21C</b>	<b>PV20.20W</b>				
<b>100</b>	<b>PV20.92X</b>	<b>PV20.96Y</b>	9	<b>PV20.22K</b>	<b>PV20.23R</b>				
<b>120</b>	<b>PV20.93D</b>	<b>PV20.97E</b>	11	<b>PV20.24X</b>	<b>PV20.25D</b>				

	<b>Internal drawer units</b> The drawers are fitted with height-adjustable, soft-close, "Quadro" type metal slides. Internal drawers in Leather grey (LG7H) finish, handle chosen from those with a pitch of 160. Can be positioned as floor-standing or suspended Dpt 50 Ht 32				<b>Internal drawer units</b> The drawers are fitted with height-adjustable, soft-close, "Quadro" type metal slides. Internal drawers in Leather grey (LG7H) finish, handle chosen from those with a pitch of 160. Can be positioned as suspended Dpt 50,8 Ht 32		<b>Internal drawer units</b> The drawers are fitted with height-adjustable, soft-close, "Quadro" type metal slides. Internal drawers in Leather grey (LG7H) finish, handle chosen from those with a pitch of 160. Can be positioned as floor-standing Ht 64		<b>Internal drawer units</b> The drawers are fitted with height-adjustable, soft-close, "Quadro" type metal slides. Internal drawers in Leather grey (LG7H) finish, handle chosen from those with a pitch of 160. Can be positioned as floor-standing Ht 96		<b>Internal drawer units</b> The drawers are fitted with height-adjustable, soft-close, "Quadro" type metal slides. Internal drawers in Leather grey (LG7H) finish, handle chosen from those with a pitch of 160. Can be positioned as floor-standing Ht 128	
For compartment <b>W</b> :	<b>Code</b>	<b>Code</b>	<b>Code</b>	<b>Code</b>	<b>Code</b>	<b>Code</b>	<b>Code</b>	<b>Code</b>	<b>Code</b>	<b>Code</b>	<b>Code</b>	
<b>60</b>	<b>PV23.00Y</b>	<b>PV23.08A</b>	<b>PV23.16T</b>	<b>PV23.20K</b>	<b>PV23.01E</b>	<b>PV23.09G</b>						
<b>90</b>	<b>PV23.02M</b>	<b>PV23.10D</b>	<b>PV23.17Z</b>	<b>PV23.21R</b>	<b>PV23.03T</b>	<b>PV23.11L</b>						
<b>100</b>	<b>PV23.04Z</b>	<b>PV23.12S</b>	<b>PV23.18F</b>	<b>PV23.22X</b>	<b>PV23.05F</b>	<b>PV23.13Y</b>						
<b>120</b>	<b>PV23.06N</b>	<b>PV23.14E</b>	<b>PV23.19N</b>	<b>PV23.23D</b>	<b>PV23.07U</b>	<b>PV23.15M</b>						

	<b>Compartment</b> Dpt 50,8 Ht 35,5			<b>Compartment with safe</b> Ht 35,5 Internal space W 50 - D 48 - H 28 Dpt 50,8		<b>Compartment with safe</b> Ht 35,5 Internal space W 50 - D 48 - H 28 Dpt 50,8		<b>Freely installable safes</b> Motorised closure. 6-digit led display. Internal led light. Master-user password. Charcoal colour. Net weight 13 Kg. Dpt 37 W 42 Ht 20	
For compartment <b>W</b> :	<b>Code</b>	<b>Code</b>	<b>Code</b>	<b>Code</b>	<b>Code</b>	<b>Code</b>	<b>Code</b>	<b>Code</b>	<b>Code</b>
<b>90</b>	<b>PV20.11X</b>	-	-	<b>PV20.07F</b>	<b>PV20.18T</b>	<b>PV20.08N</b>	<b>PV20.19Z</b>		
<b>100</b>	-	<b>PV20.09U</b>	-	<b>PV20.02Y</b>	<b>PV20.13L</b>	<b>PV20.03E</b>	<b>PV20.14S</b>		
<b>120</b>	-	-	<b>PV20.10R</b>	<b>PV20.04M</b>	<b>PV20.15Y</b>	<b>PV20.05T</b>	<b>PV20.16E</b>		
<b>135</b>	-	-	-	<b>PV20.06Z</b>	<b>PV20.17M</b>	-	-	<b>Code PV00.96S</b>	

□ Components in **CARCASE** colors



⚡ Included: the led profile already applied to the top/shelf, the modification for the cable passage, and 2 metres of cable for connection to the power adapter. **To be completed with power adapter(s) as indicated in "Power adapters and switches"**.

⦿ Elements equipped with side cross-pieces for fixing to the central aluminium frame side; codes also to be used when the elements are to be positioned between one aluminium frame side and one panel side. In order to use these elements, our graphic software must be used, equipping the accessory inside the relative carcass.

**p. 510** Power adapters and switches

# Accessories for modular wardrobes

## Internal partitions

Shelf Th 3.5, vertical partition Th 2.5

Dpt 50,8

W 90

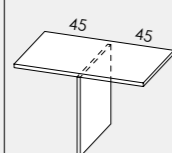

Specify vertical L or R partition (right-hand images)

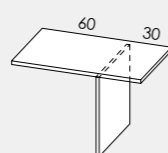

W 100

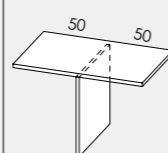

They generate specific holes on bottom

W 120

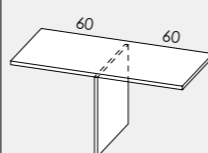

Specify vertical L or R partition (right-hand images)

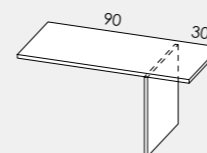

W 135

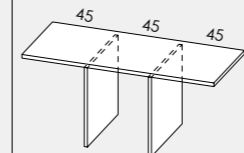

Specify vertical L or R partition (right-hand images)

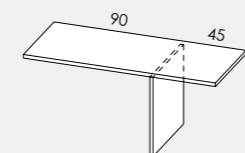

Ht:	Code		Code		Code		Code		Code		Code		Code	
67,8	PV22.00U	*	PV22.08W	*	PV22.16P	*	PV22.24F		PV22.32Y		PV22.40R		PV22.48T	
99,8	PV22.02G	*	PV22.10Z	*	PV22.18B	*	PV22.26U		PV22.34M		PV22.42D		PV22.50W	
131,8	PV22.04V	*	PV22.12N	*	PV22.20E	*	PV22.28G		PV22.36Z		PV22.44S		PV22.52K	
195,8	PV22.06H	*	PV22.14A	*	PV22.22T	*	PV22.30L	*	PV22.38N	*	PV22.46E	*	PV22.54X	*

## Internal partitions

Shelf Th 3.5, vertical partition Th 2.5

Dpt 50,8

W 90

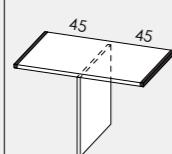

Specify vertical L or R partition (right-hand images)

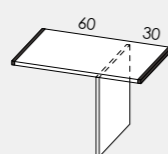

W 100

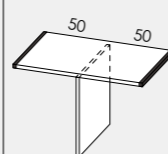

They generate specific holes on bottom

W 120

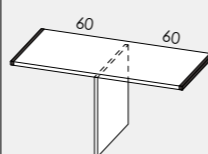

Specify vertical L or R partition (right-hand images)

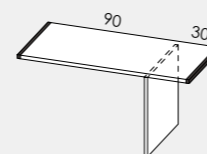

W 135

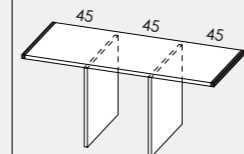

Specify vertical L or R partition (right-hand images)

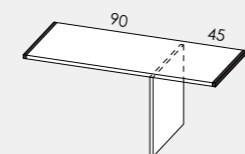

	Code		Code		Code		Code		Code		Code		Code	
67,8	PV22.01A	*	PV22.09C	*	PV22.17V	*	PV22.25N		PV22.33E		PV22.41X		PV22.49Z	
99,8	PV22.03P	*	PV22.11F	*	PV22.19H	*	PV22.27A		PV22.35T		PV22.43L		PV22.51C	
131,8	PV22.05B	*	PV22.13U	*	PV22.21M	*	PV22.29P		PV22.37F		PV22.45Y		PV22.53R	
195,8	PV22.07Q	*	PV22.15G	*	PV22.23Z	*	PV22.31S	*	PV22.39U	*	PV22.47M	*	PV22.55D	*

## Lighting with sensor

Complete kits with 1 Power pack.  
Cover color Aluminum and Titanium.

Dpt 19,2

W 11,2

Th 0,6

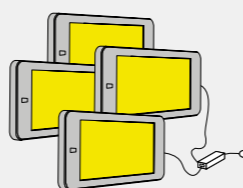
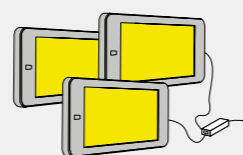
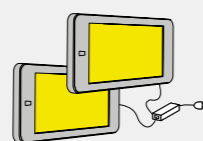
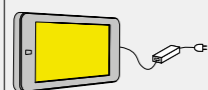

Code	P08.71B	P08.72G	P08.73N	P08.74T					

☐ Components in **CARCASE** colors

\* It is essential to insert at least one shelf or internal drawer unit to guarantee stability to the side.

⊙ Elements equipped with side cross-pieces for fixing to the central aluminium frame side; codes also to be used when the elements are to be positioned between one aluminium frame side and one panel side. In order to use these elements, our graphic software must be used, equipping the accessory inside the relative carcass.

# Power adapters and switches

## Power adapters with motion sensors

### 24 V power kit with PIR sensor

Kit consisting of power adapter and motion sensor, for top/shelf with led profile; includes 2 linear metres of cable with Europe plug. Each power adapter has 9 outputs to connect from 1 to 9 led profiles, to order the correct code calculate the total watt consumption for each compartment. **1 kit must be ordered for each wardrobe compartment.**

The motion sensor works as a switch. The connected lamps are turned on and off when changes are detected in the temperature combined with movement within its range of action.

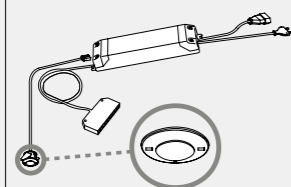

15 Watt

30 Watt

60 Watt

100 Watt

Code	PV00.62Z	PV00.63F	PV00.64N	PV00.61T		

Example with watt consumption and number of power adapters to order.

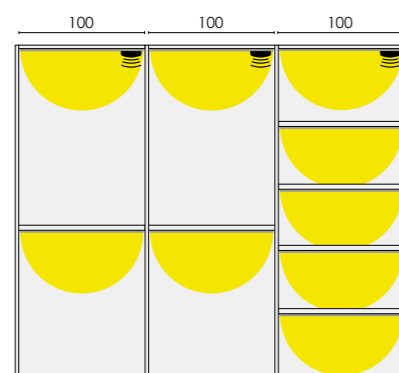

### Wardrobe 3 compartments W 100

2 compartments W 100 with led on top (9 watt) and led on shelf (9 watt). Total 18 watt per compartment.  
1 compartment W 100 with led on top (9 watt x 4) and led on shelves (9 watt x 4). Total 45 watt.

Order 2 x 30 watt power adapter with sensor kits Code PV00.63F and 1 x 60 watt power adapter with sensor kit Code PV00.64N.

**Metron allows automatic calculation of the grounding for the power adapter or switches on the single wardrobe composition.**

## Power adapter and Wireless switches

### 24 V power adapter with cable

Power adapters for direct connection to the mains (socket controlled by a bipolar switch) for top/shelf with led profile; includes 2 linear metres of cable with Europe plug. Each power adapter has 6 outputs to connect from 1 to 6 led profiles; for the number of power adapters to order, calculate the total watt consumption.

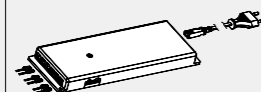

30 Watt

60 Watt

### Remote control

The remote control is a wireless switch (single channel or multi-channel) using which it is possible to turn on, off, and regulate the brightness of the led profiles connected to the receiving power adapter.

**1 remote control must be ordered for each power adapter.**



### Bluetooth application board

The remote control module activates the Bluetooth function that allows you to manage the lights from your smartphone thanks to the dedicated App.

**1 board must be ordered for each power adapter.**



Code	PV20.00L	PV20.01S	PV00.60M	PV00.59Q

Example with watt consumption and number of power adapters to order.

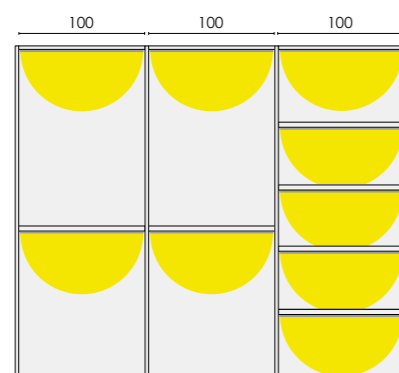

### Wardrobe 3 compartments W 100

2 compartments W 100 with led on top (9 watt) and led on shelf (9 watt).  
1 compartment W 100 with led on top (9 watt x 4) and led on shelves (9 watt x 4). Total watt 81.

Order 1 x 30 watt power adapter Code PV20.00L to connect 3 led lamps (27 watt) and 1 x 60 watt power adapter Code PV20.01S to connect 6 led lamps (54 watt).

**Metron allows automatic calculation of the grounding for the power adapter or switches on the single wardrobe composition.**

Colour correspondence key

CARCASE color

GROUP 3 colors

Types and colors FRONT



**CONCRETA**  
Th 2,5

**CUTTING**  
Th 2,5

--	--	--	--	--	--	--

**CUTTING PLUS**  
Th 2,5

--	--	--	--

--	--	--	--

**WINDOW**  
Th 2,1

--	--

**Modular wardrobes - Hinged doors**

Wardrobes - technical information	514
Made-to-measure solutions for hinged doors	516
Modular components Ht 225.8	518
Modular components Ht 241.8	520
Modular components Ht 257.8	522
Modular components Ht 289.8	524
Modular wardrobes	526
Overhead wardrobes - technical information	528
Overhead wardrobes compositions	530
Wardrobes with niche	531
Wardrobes with console	532
Wardrobes with TV mount	533

All the modular wardrobes in the price list are presented with panel sides.

512

☆ Finishing with textured effect    ★ UV glossy finishing

513

Modular wardrobes  
Hinged doors



# Wardrobes - technical information

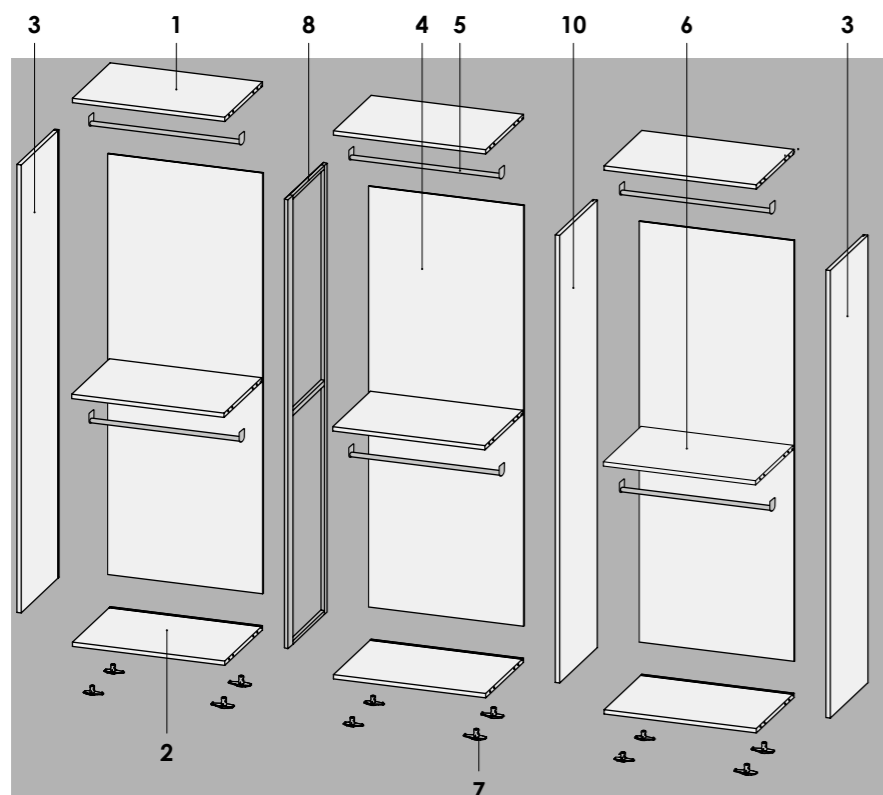

## Components:

- 1 Top panel Th 2.5
- 2 Bottom panel Th 2.5
- 3 Side panels Th 2.5
- 4 Back panel Th 0.8 - Fitting into shaped connection.
- 5 PLUS clothes hanging bar in aluminum.
- 6 Movable shelf Th 3.5
- 7 Adjustable feet
- 8 Central side aluminium frame Th 2.5 (optional)  
Carbon grey (CG8X) finish. **Exclusive for H 257,8**
- 9 Inner side panel Th 2.5
- 10 Central side panel Th 2.5

## Dimensions:

<b>W</b>	45 - 50 - 60 - 90 - 100 - 120
<b>Dpt</b>	61,5    61,8    62,2
	STYLE    WINDOW    CONCRETA CUTTING CUTTIN PLUS
<b>Ht</b>	225,8 - 241,8 - 257,8 - 289,8

- The side panels are flush with the top and bottom.
- Tops are not finished.
- Top panels, bottom panels, movable shelves, back panels and central side panels in Leather grey (LG7H) finish.
- The modules must always be completed with by a final side and ordered from left to right.
- For assembly, at least an extra 4 cm in width is required (if the "kit for assembly in niche" Code PV00.58H is ordered, 2 cm are sufficient).

### IMPORTANT!

- Internal fittings supplied consist in: 1 clothes hanging bar in line with doors Ht 128 - 160 - 192; 2 clothes hanging bars and 1 movable shelf in line with doors Ht 224 - 256 - 288.
- For custom cuts consult the relevant chapter.

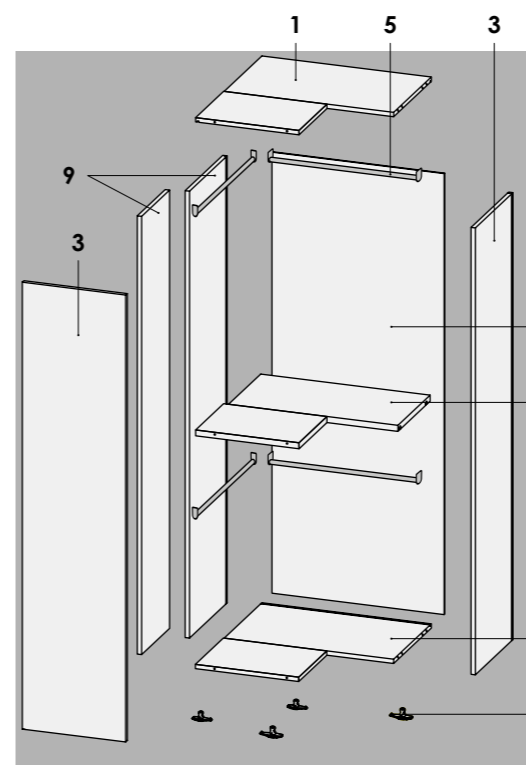

## Corner

- It must always be combined with another module.
- For assembly, at least an extra 4 cm in width is required (if the "kit for assembly in niche" Code PV00.58H is ordered, 2 cm are sufficient).

## Made-to-measure gap for corner module:

**114,00** surcharge for made-to-measure gap (compared to the list price of the element with universal gap).

Always start with the universal gap kit and set the gap size of the pillar.  
To add shelves, they must be indicated with a drawing inside the corner module.

- 140 mm : Minimum gap width
- 395 mm : Maximum gap width

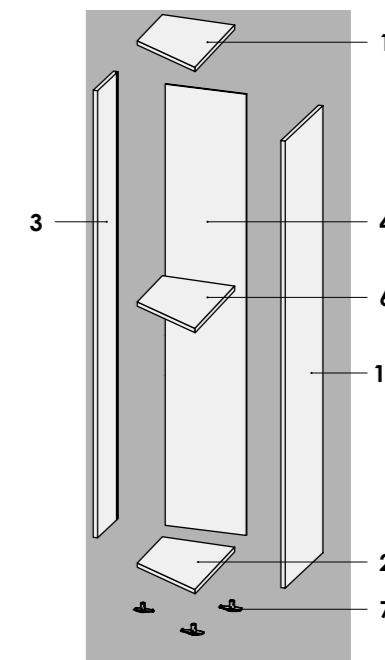
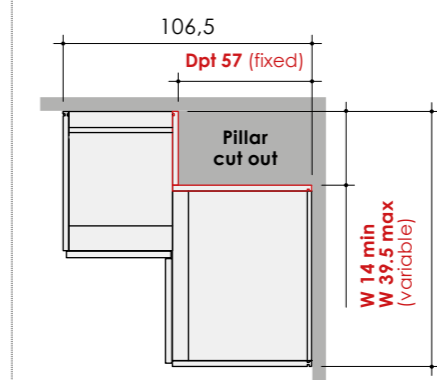
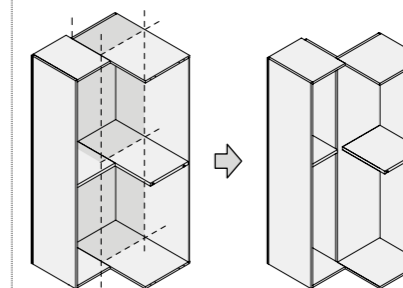

## End element

- It must always be combined with another module.
- For assembly, at least an extra 4 cm in width is required (if the "kit for assembly in niche" Code PV00.58H is ordered, 2 cm are sufficient).

## Modular wardrobes with hinged doors

### Widths

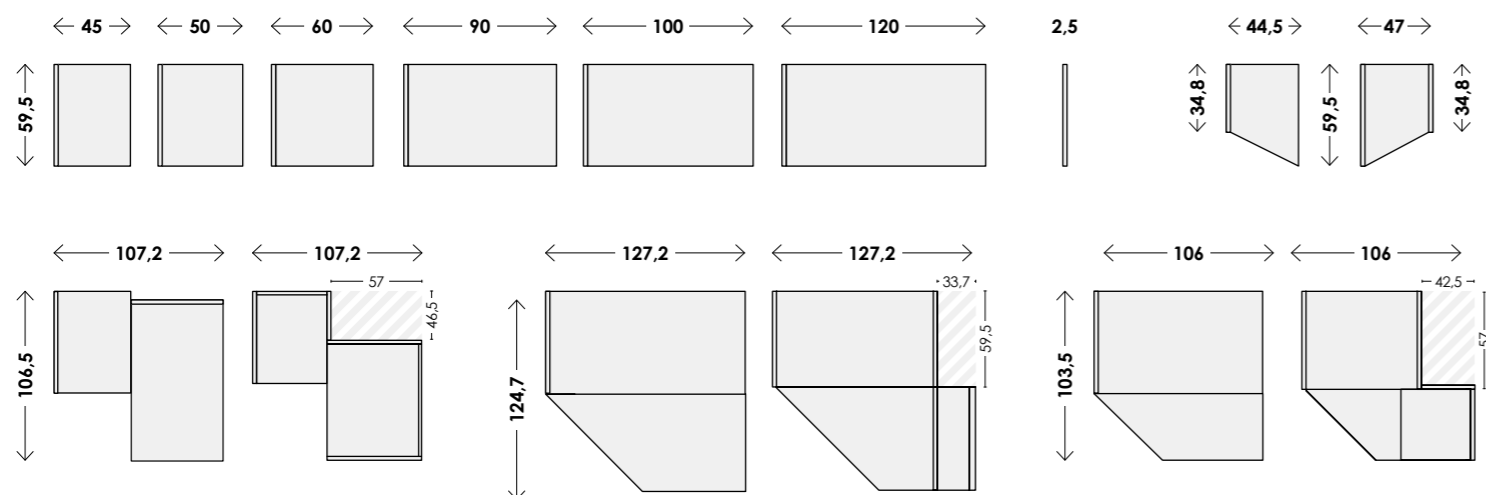

## Over-door wardrobe - technical specifications

**Made-to-measure reducible over-door wardrobe, when placing the order indicate the height and width of the doorway.**

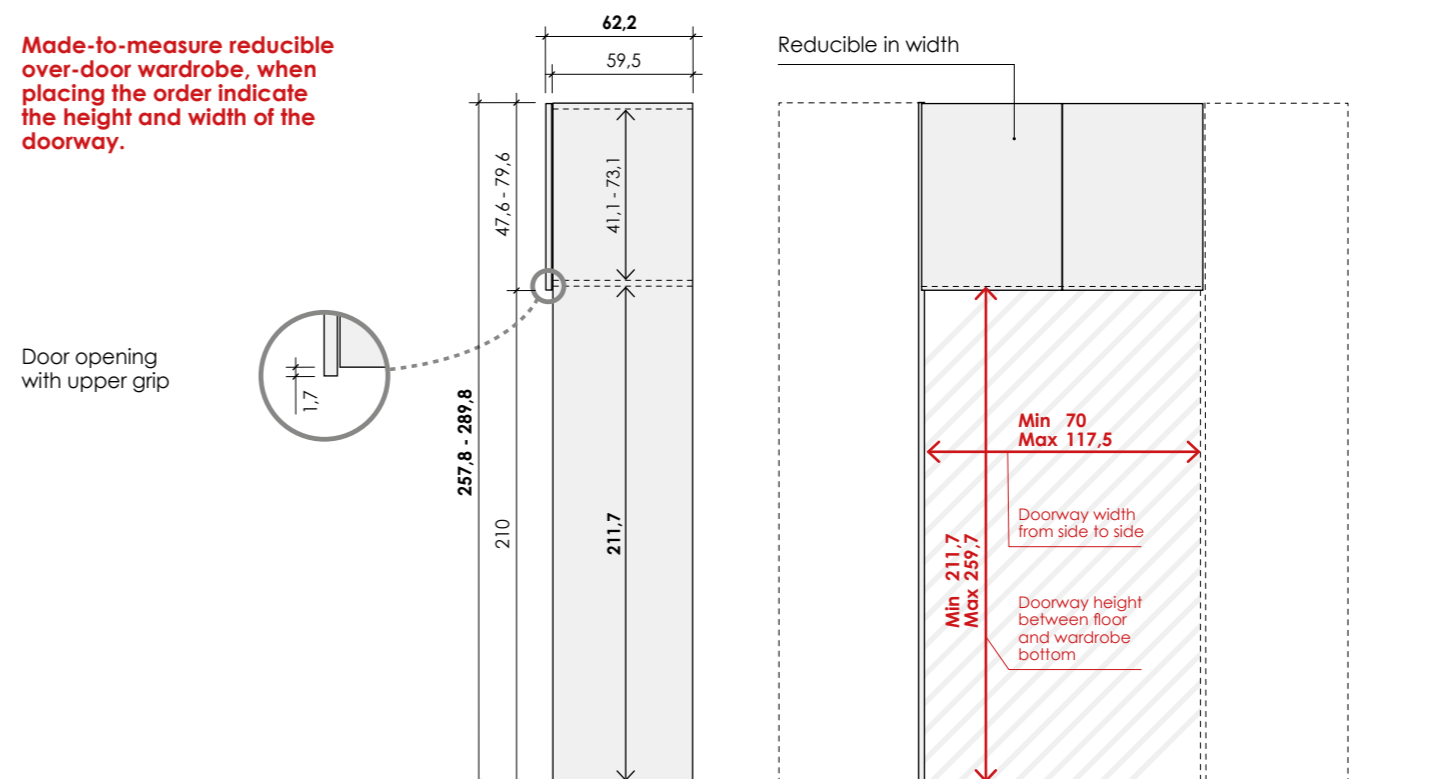



# Made-to-measure solutions for hinged doors

## 🕒 Pitched roof cut

Minimum finished door slant 50°

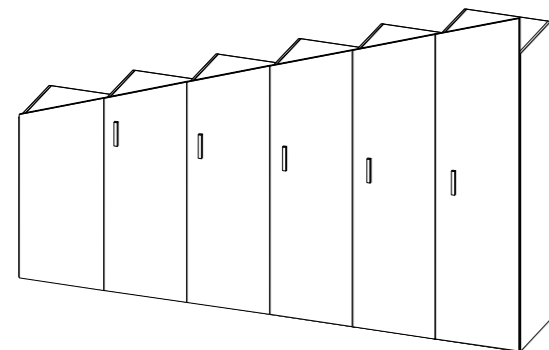

Pitched roof cut on all elements.

FRONT VIEW  
Example 1:

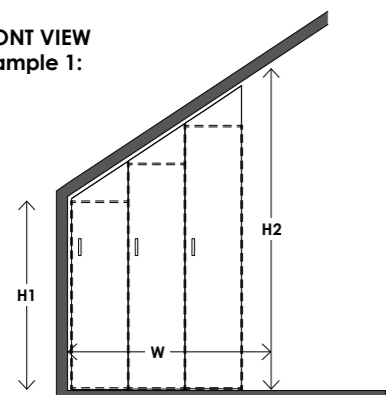

When ordering, you must:

- Place single modules (W 45/50/60) side by side for the desired length.
- Indicate the height of the LH wall (H1).
- Indicate the length (W) and the height of RH wall (H2).

Pitched roof cuts are made to measure only if requested with a detailed drawing.

POSSIBLE CUTS:

- Single wardrobe carcasses (W 45/50/60)
- ONE door at full-height

658 mm : Minimum wardrobe structure height  
2570 mm: Maximum wardrobe structure height

Pitched roof cut flanked by linear wardrobe.

FRONT VIEW  
Example 2:

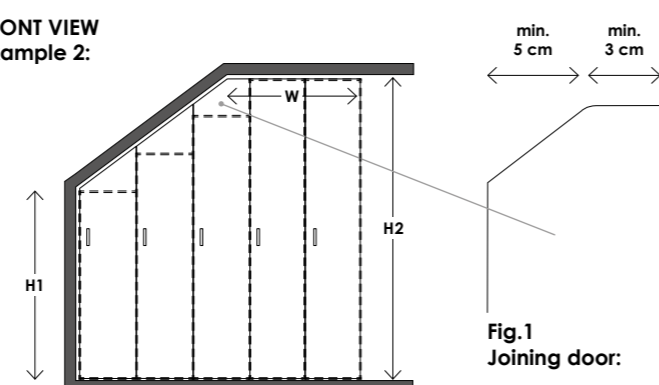

When ordering, you must:

- Place single modules (W 45/50/60) side by side for the desired length.
- Indicate the height of the LH wall (H1).
- Indicate the height of the RH wall (H2).
- Indicate the length (W) of the linear part.

N.B. A joining door will be created which will be aligned with the doors of the straight wardrobe (Fig.1).

### CAUTIONS:

- The wardrobe must consist of standard modules W 45/50/60 with full-height door; it is possible to reduce the height and width with the relative rules in the "Custom cuts" chapter.
- The hinges must always be positioned on the highest side of the door.
- Doors, which are lower by 110 cm, on the handle side, will be supplied with push pull opening.
- A 3 cm technical tolerance is always allowed between the diagonal of the ceiling and the diagonal of the door cut.
- An additional width of 4 cm on the highest side of the composition for assembly.

## Corner for wardrobe joins with pitched roof cut and protruding doors

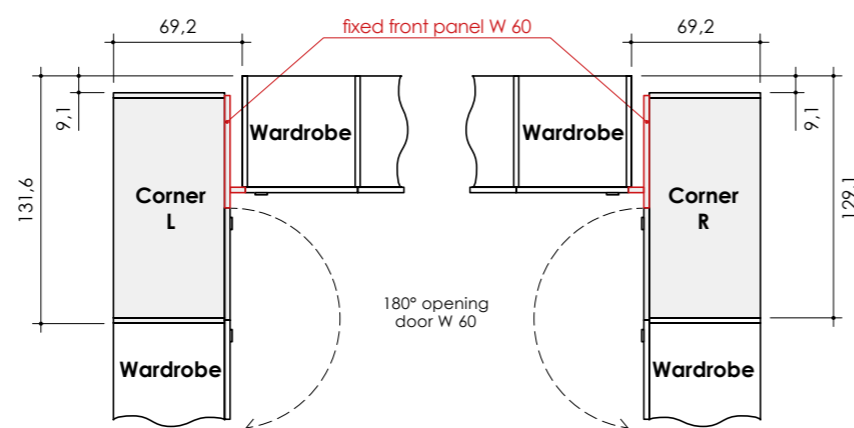
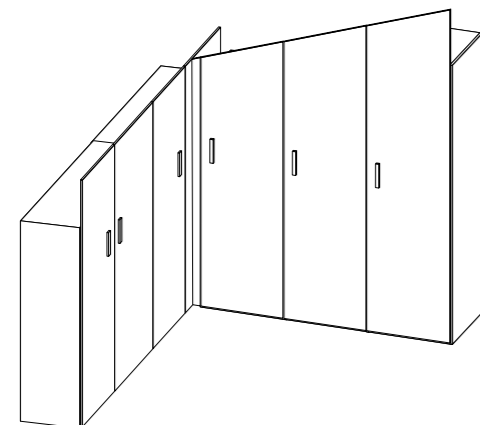

## 🕒 Door protruding in height



SIDE VIEW  
Example 1:

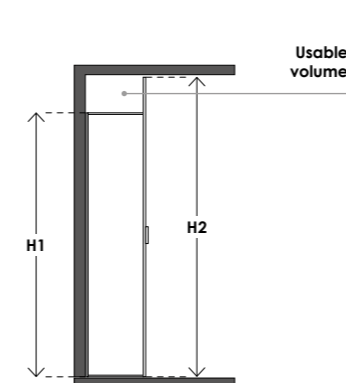

When ordering, you must:

- Place modules side by side for the desired length.
- Indicate the height of the wardrobe carcass (H1).
- Indicate the height of the door (H2).

Compositions can be created with protruding doors only if requested with detailed drawing.

POSSIBLE CUTS:

- ONE door at full height

658 mm : Minimum wardrobe structure height  
2578 mm: Maximum wardrobe structure height

SIDE VIEW  
Example 2:

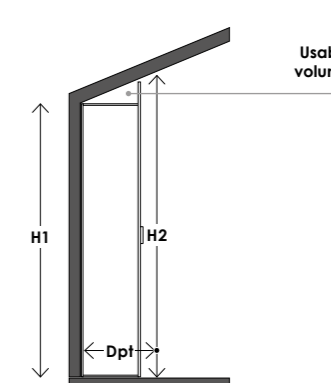

When ordering, you must:

- Place modules side by side for the desired length.
- Indicate the minimum height of the wall (H1).
- Indicate the depth (Dpt) and the maximum height of the wall (H2).

### CAUTIONS:

- The wardrobe must be composed of modules with standard structures, possibly reduced in height, width and depth with the relevant rules in the "Custom cuts" chapter.
- The doors can protrude a max. of 40 cm compared to the carcass.
- Doors, which are lower by 110 cm, will be supplied with push pull opening.
- In the case of a sloping ceiling (see example 2), a technical tolerance of 3 cm between the ceiling and the protruding door is always considered.
- An additional width of 4 cm is required for assembly.

	L corner with opening and fixed doors W 60	R corner with opening and fixed doors W 60		
Code	PV10.41L	PV10.40D		
CONCRETA	Th 2.5			

□ Components in CARCASE colors

■ Components in Types and colors FRONT

🕒 Delivery approximately 4 weeks from order receipt.

# Modular components Ht 225.8

## Wardrobes

Specify hinge  
R or L

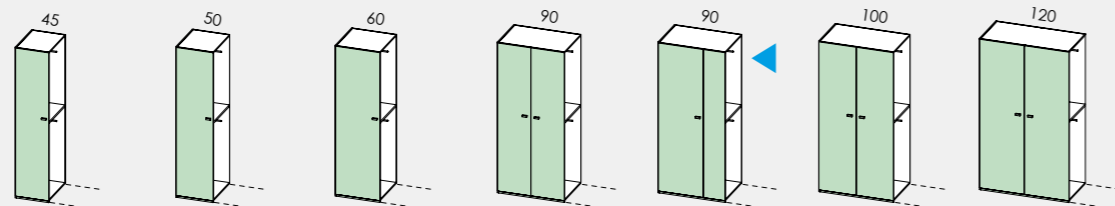

Code	PV10.01P	PV10.04H	PV10.07C	PV10.10N	PV10.11U	PV10.14P	PV10.17H
STYLE	Th 1.8						
	matte						
	glossy						
CONCRETA	Th 2.5						
CUTTING	Th 2.5						
CUTTING PLUS	Th 2.5						
WINDOW	Th 2.1						

## Seasonal wardrobes

Specify hinge  
R or L

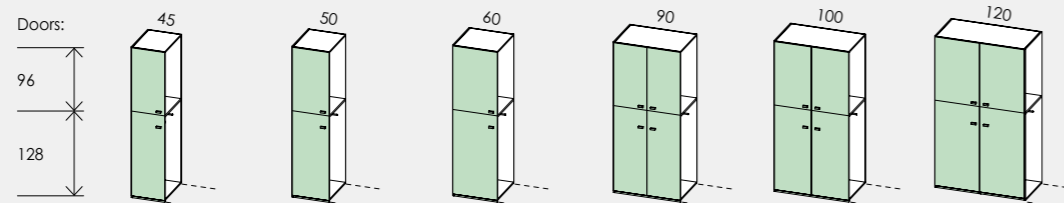

Code	PV10.02V	PV10.05Q	PV10.08K	PV10.12A	PV10.15V	PV10.18Q
CONCRETA	Th 2.5					

## Seasonal wardrobes

Specify hinge  
R or L

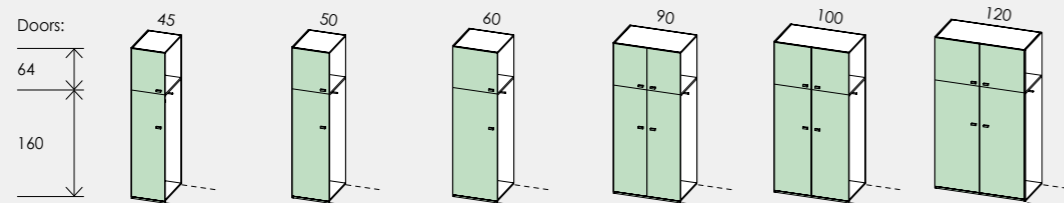

Code	PV10.03B	PV10.06W	PV10.09R	PV10.13G	PV10.16B	PV10.19W
CONCRETA	Th 2.5					

- Components in **CARCASE** colors
- Components in **GROUP 3** colors
- Components in **Types and colors FRONT**
- ▼ With doors W 30 + W 60 - Indicate R or L (drawing - L)

With universal gap

## Corners

2 doors W 45

They must always be placed side by side with another module.

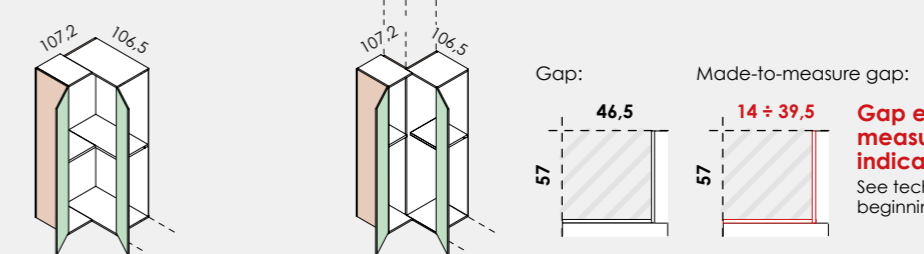

Code	PV10.20T	PV10.21Z				
STYLE	Th 1.8					
	matte					
	glossy					
CONCRETA	Th 2.5					
CUTTING	Th 2.5					
CUTTING PLUS	Th 2.5					
WINDOW	Th 2.1					

## End elements

1 door W 50

They must always be placed side by side with another module.

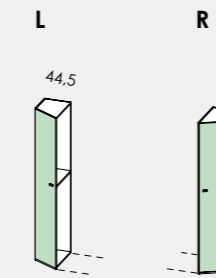

Code	PV10.23N	PV10.22F				
STYLE	Th 1.8					
	matte					
	glossy					
CONCRETA	Th 2.5					
CUTTING	Th 2.5					
CUTTING PLUS	Th 2.5					
WINDOW	Th 2.1					

## End side panel Th 2.5

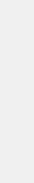

Code	PV10.00G					

- p. 496** Handle positions
- p. 502** Filler strips for modular wardrobes
- p. 504** Accessories for modular wardrobes

# Modular components Ht 241.8

## Wardrobes

Specify hinge  
R or L

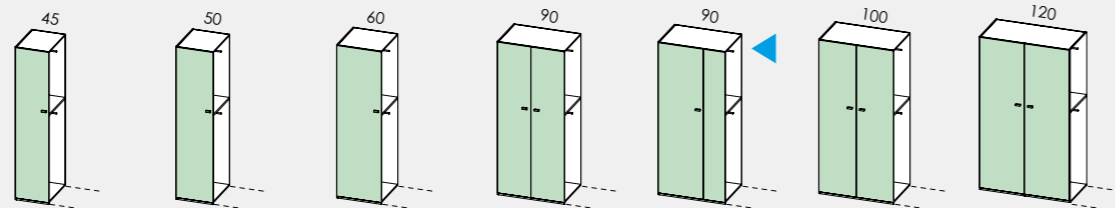

Code	PV11.01T	PV11.04N	PV11.07G	PV11.10S	PV11.11Y	PV11.14T	PV11.17N
STYLE	Th 1.8						
	matte						
	glossy						
CONCRETA	Th 2.5						
CUTTING	Th 2.5						
CUTTING PLUS	Th 2.5						
WINDOW	Th 2.1						

## Seasonal wardrobes

Specify hinge  
R or L

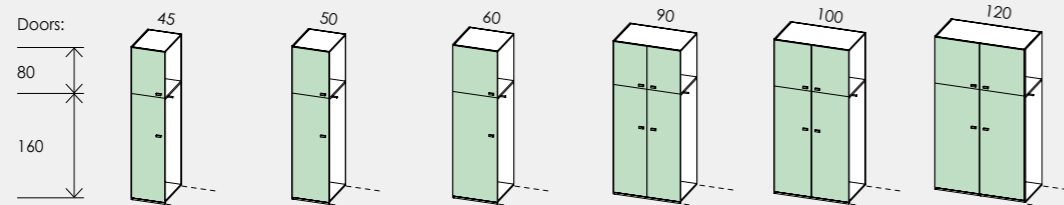

Code	PV11.02Z	PV11.05U	PV11.08P	PV11.08P	PV11.15Z	PV11.18U
CONCRETA	Th 2.5					

## Seasonal wardrobes

Specify hinge  
R or L

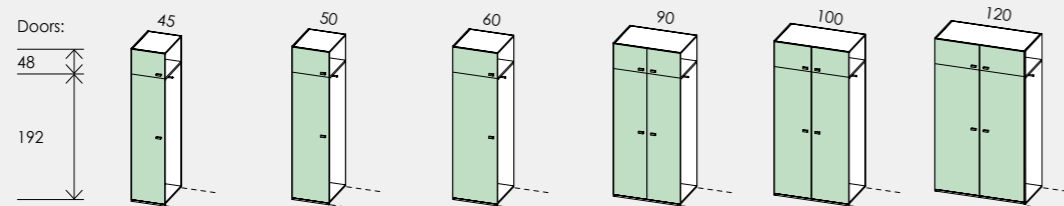

Code	PV11.03F	PV11.06A	PV11.09V	PV11.13M	PV11.16F	PV11.19A
CONCRETA	Th 2.5					

- Components in **CARCASE** colors
- Components in **GROUP 3** colors
- Components in **Types and colors FRONT**
- ▼ With doors W 30 + W 60 - Indicate R or L (drawing - L)

## Corners

2 doors W 45

They must always be placed side by side with another module.

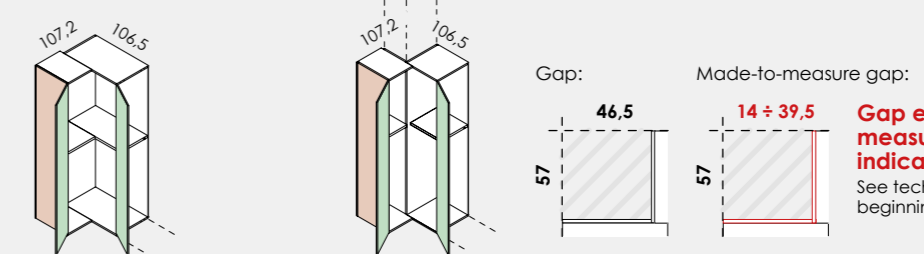

Code	PV11.20X	PV11.21D				
STYLE	Th 1.8					
	matte					
	glossy					
CONCRETA	Th 2.5					
CUTTING	Th 2.5					
CUTTING PLUS	Th 2.5					
WINDOW	Th 2.1					

## End elements

1 door W 50

They must always be placed side by side with another module.

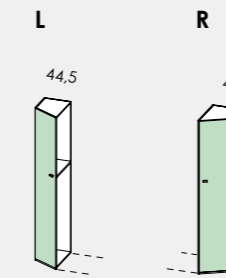

Code	PV11.23S	PV11.22L				
STYLE	Th 1.8					
	matte					
	glossy					
CONCRETA	Th 2.5					
CUTTING	Th 2.5					
CUTTING PLUS	Th 2.5					
WINDOW	Th 2.1					

## End side panel Th 2.5



Code	PV11.00M					
	97,00					

- p. 496** Handle positions
- p. 502** Filler strips for modular wardrobes
- p. 504** Accessories for modular wardrobes

# Modular components Ht 257.8

## Wardrobes

Specify hinge  
R or L

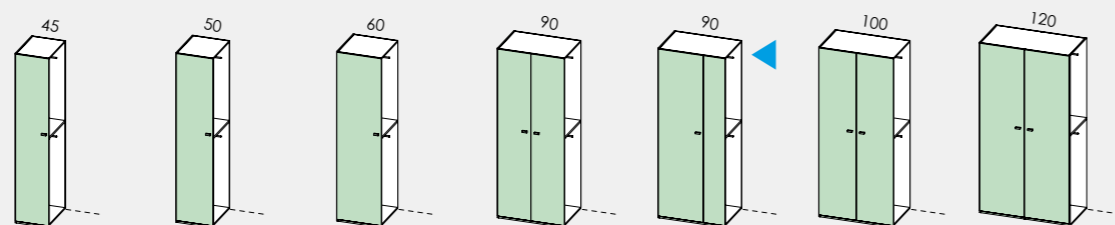

Code	PV12.01X	PV12.05Y	PV12.09Z	PV12.13R	PV12.14X	PV12.18Y	PV12.22Q
STYLE	Th 1.8						
	matte						
	glossy						
CONCRETA	Th 2.5						
CUTTING	Th 2.5						
CUTTING PLUS	Th 2.5						
WINDOW	Th 2.1						

## Seasonal wardrobes

Specify hinge  
R or L

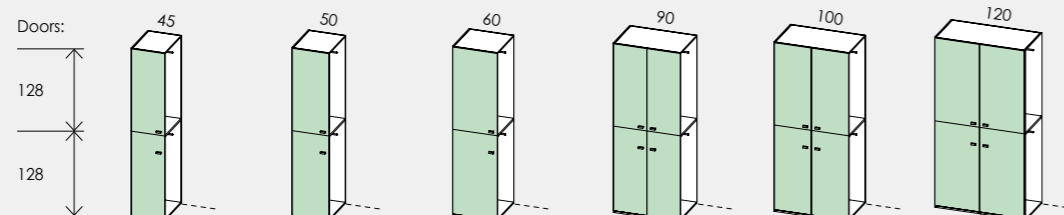

Code	PV12.02D	PV12.06E	PV12.10W	PV12.15D	PV12.19E	PV12.23W
CONCRETA	Th 2.5					

## Seasonal wardrobes

Specify hinge  
R or L

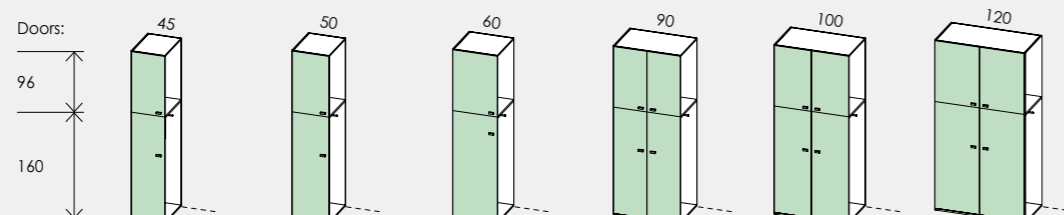

Code	PV12.03L	PV12.07M	PV12.11C	PV12.16L	PV12.20B	PV12.24C
CONCRETA	Th 2.5					

## Seasonal wardrobes

Specify hinge  
R or L

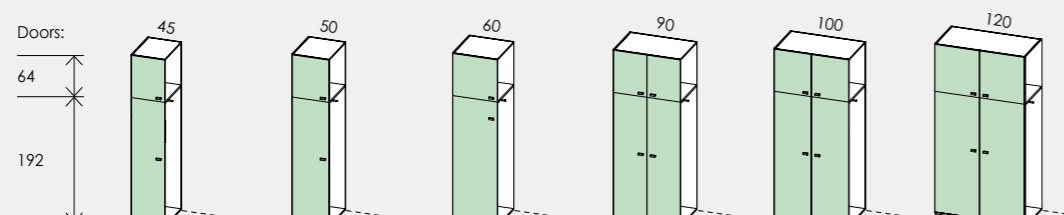

Code	PV12.04S	PV12.08T	PV12.12K	PV12.17S	PV12.21H	PV12.25K
CONCRETA	Th 2.5					

- Components in **CARCASE** colors
- Components in **GROUP 3** colors
- Components in **Types and colors FRONT**
- With doors W 30 + W 60** - Indicate R or L (drawing - L)

With universal gap

## Corners

2 doors W 45

They must always be placed side by side with another module.

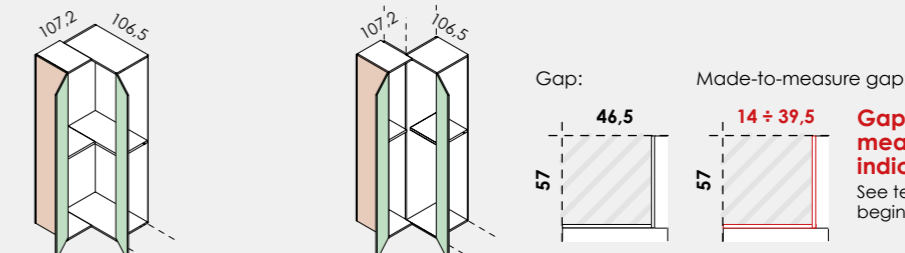

Code	PV12.26R	PV12.27X			
STYLE	Th 1.8				
	matte				
	glossy				
CONCRETA	Th 2.5				
CUTTING	Th 2.5				
CUTTING PLUS	Th 2.5				
WINDOW	Th 2.1				

## End elements

1 door W 50

They must always be placed side by side with another module.

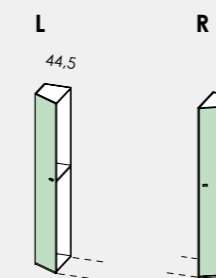

Code	PV12.29L	PV12.28D			
STYLE	Th 1.8				
	matte				
	glossy				
CONCRETA	Th 2.5				
CUTTING	Th 2.5				
CUTTING PLUS	Th 2.5				
WINDOW	Th 2.1				

## Over-door wardrobe

Must always be joined to another module, both on the right and on the left. Not rear-finished.

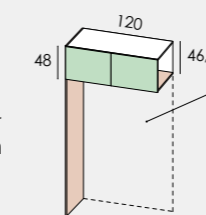

Doorway dimensions:  
W 117.5 - H 211.7

**Made-to-measure reducible over-door wardrobe, when placing the order indicate the height and width of the doorway.**  
See technical information at the beginning of the chapter.

Code	PV12.30G			
CONCRETA	Th 2.5			

## Side panels Th 2.5

End side panel

Central side aluminium frame (optional)

Carbon grey (CG8X) finish

**Not applicable to seasonal wardrobes.**

Code	PV12.00R	PV10.42S		

# Modular components Ht 289.8

## Wardrobes

Specify hinge  
R or L

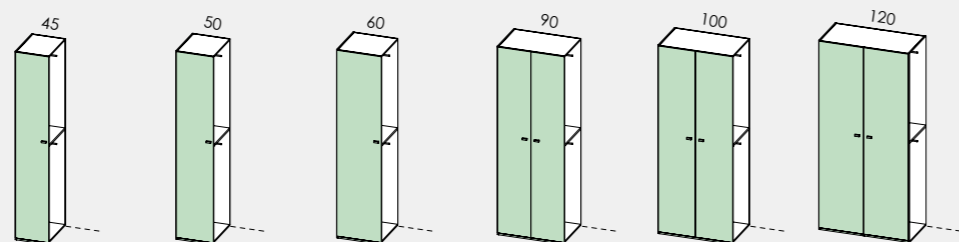

<b>Code</b>	PV13.01B	PV13.05C	PV13.09D	PV13.13V	PV13.17W	PV13.21N			
CONCRETA Th 2.5									

## Seasonal wardrobes

Specify hinge  
R or L

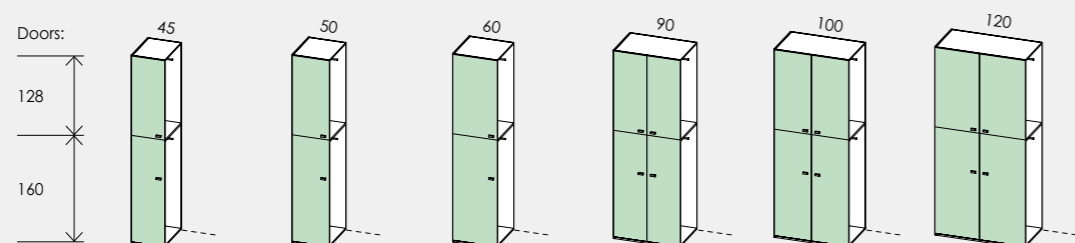

<b>Code</b>	PV13.02H	PV13.06K	PV13.10A	PV13.14B	PV13.18C	PV13.22U			
CONCRETA Th 2.5									

## Seasonal wardrobes

Specify hinge  
R or L

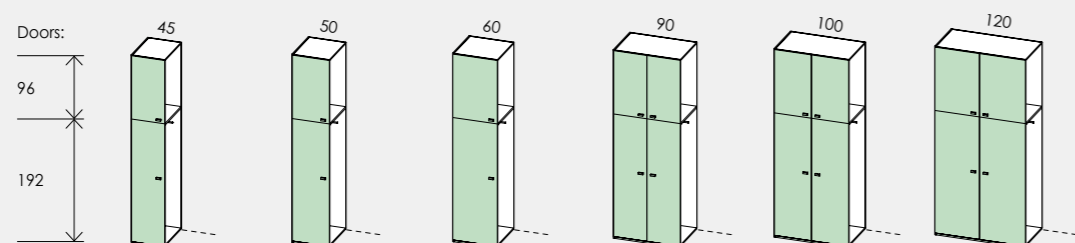

<b>Code</b>	PV13.03Q	PV13.07R	PV13.11G	PV13.15H	PV13.19K	PV13.23A			
CONCRETA Th 2.5									

## Seasonal wardrobes

Specify hinge  
R or L

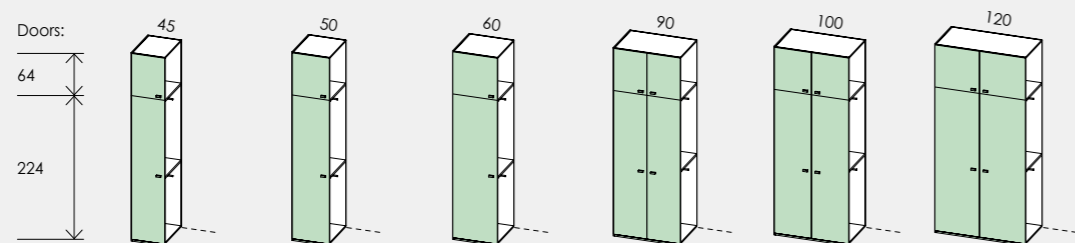

<b>Code</b>	PV13.04W	PV13.08X	PV13.12P	PV13.16Q	PV13.20F	PV13.24G			
CONCRETA Th 2.5									

- Components in **CARCASE** colors
- Components in **GROUP 3** colors
- Components in **Types and colors FRONT**

With universal gap

## Corners

2 doors W 45

They must always be placed side by side with another module.

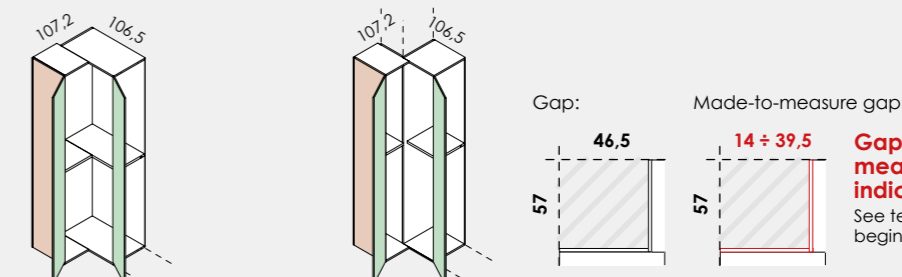

<b>Code</b>	PV13.25P	PV13.26V			
CONCRETA Th 2.5					

**Gap executable to measure, when ordering indicate the desired size.**  
See technical information at the beginning of the chapter.

## Over-door wardrobe

Must always be joined to another module, both on the right and on the left. Not rear-finished.

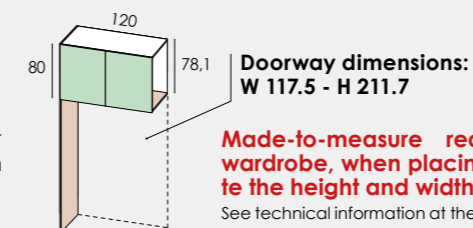

**Made-to-measure reducible over-door wardrobe, when placing the order indicate the height and width of the doorway.**  
See technical information at the beginning of the chapter.

<b>Code</b>	PV13.27B				
CONCRETA Th 2.5					

## End side panel Th 2.5



<b>Code</b>	PV13.00V				

# Modular wardrobes

## Ht 225.8

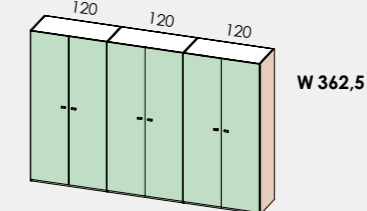
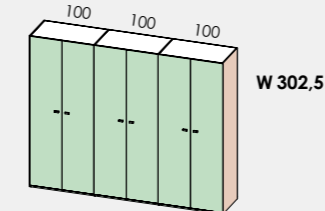
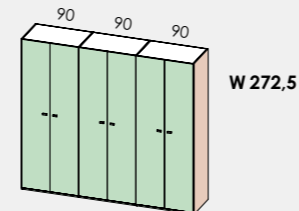
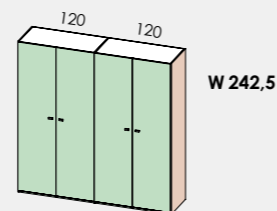
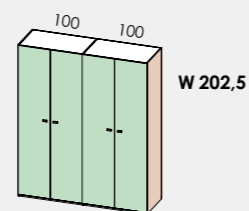
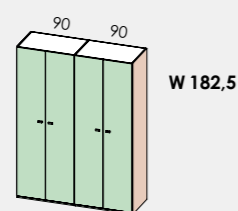

<b>Code</b>	<b>PV10.30Y</b>	<b>PV10.31E</b>	<b>PV10.32M</b>	<b>PV10.33T</b>	<b>PV10.34Z</b>	<b>PV10.35F</b>	
STYLE	Th 1.8 matte glossy						
CONCRETA	Th 2.5						
CUTTING	Th 2.5						
CUTTING PLUS	Th 2.5						
WINDOW	Th 2.1						

## Ht 241.8

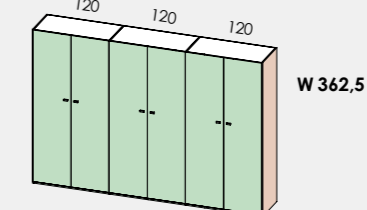
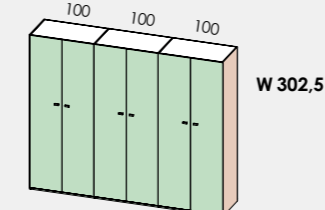
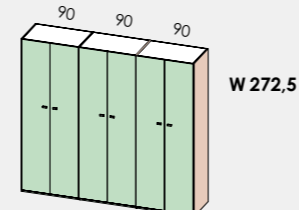
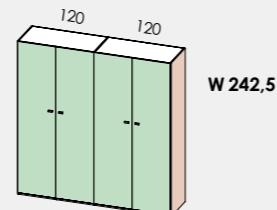
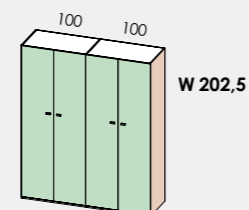
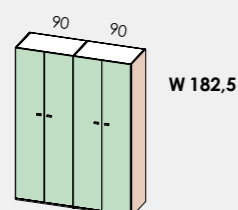

<b>Code</b>	<b>PV11.30C</b>	<b>PV11.31K</b>	<b>PV11.32R</b>	<b>PV11.33X</b>	<b>PV11.34D</b>	<b>PV11.35L</b>	
STYLE	Th 1.8 matte glossy						
CONCRETA	Th 2.5						
CUTTING	Th 2.5						
CUTTING PLUS	Th 2.5						
WINDOW	Th 2.1						

## Ht 257.8

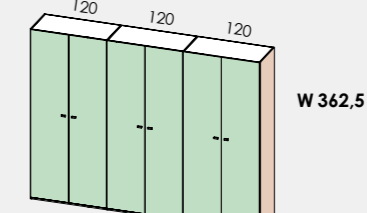
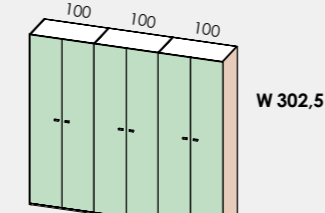
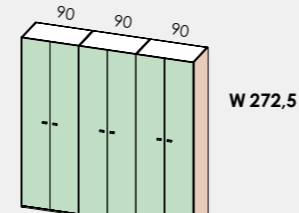
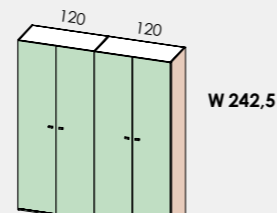
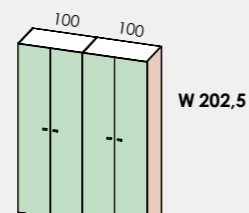
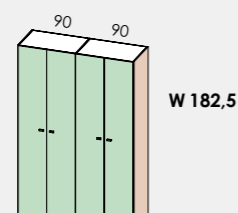

<b>Code</b>	<b>PV12.40N</b>	<b>PV12.41U</b>	<b>PV12.42A</b>	<b>PV12.43G</b>	<b>PV12.44P</b>	<b>PV12.45V</b>	
STYLE	Th 1.8 matte glossy						
CONCRETA	Th 2.5						
CUTTING	Th 2.5						
CUTTING PLUS	Th 2.5						
WINDOW	Th 2.1						

## Ht 289.8

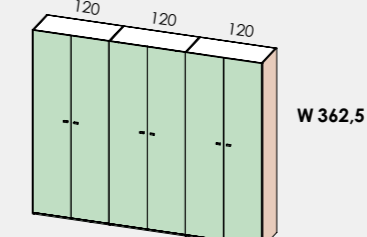
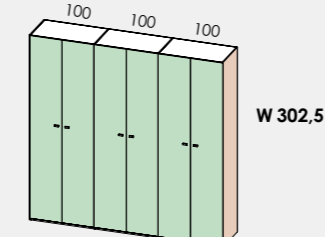
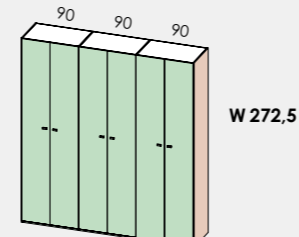
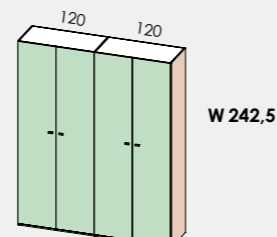
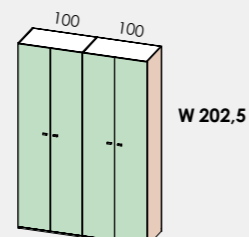
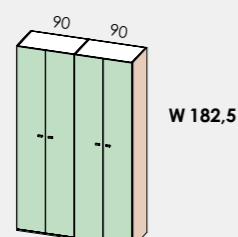

<b>Code</b>	<b>PV13.30M</b>	<b>PV13.31T</b>	<b>PV13.32Z</b>	<b>PV13.33F</b>	<b>PV13.34N</b>	<b>PV13.35U</b>	
CONCRETA	Th 2.5						

- Components in **CARCASE** colors
- Components in **GROUP 3** colors
- Components in **Types and colors FRONT**



# Overhead wardrobes - technical information

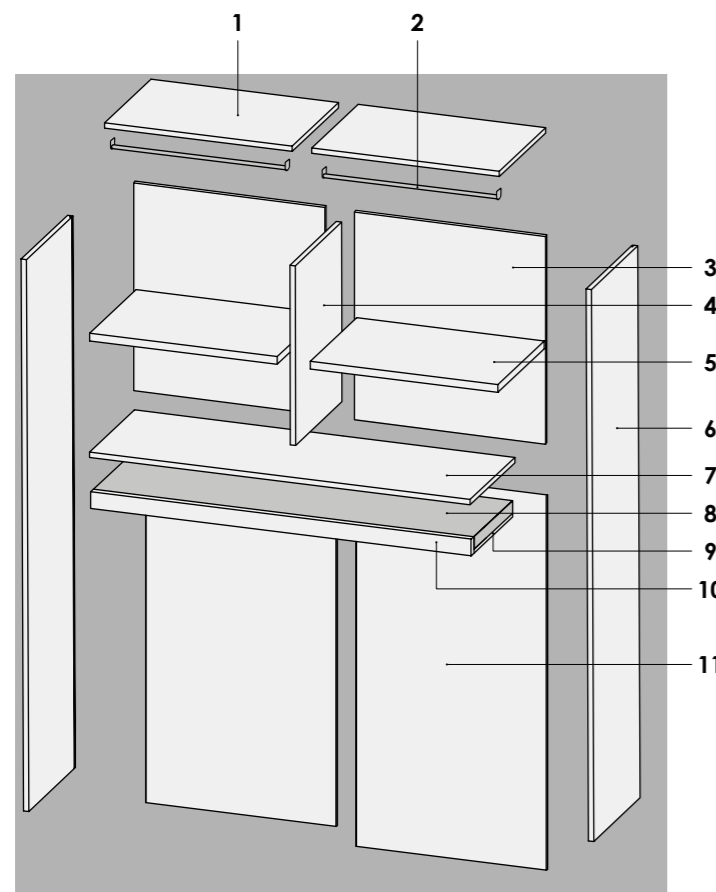

Components:

- 1 Top panel Th 2.5
- 2 PLUS clothes hanging bar (Wall units Ht 127.6)
- 3 Back panel Th 0.8 - fitting into shaped connection.
- 4 Central side Th 2.5
- 5 Movable shelf Th 3.5
- 6 Side panels Th 2.5
- 7 Bottom panel Th 2.5
- 8 Iron frame H 6
- 9 Frame cover vault Th 1.8
- 10 Frame cover facing Th 1.8 - Ht 7.8
- 11 Under-overhead back panel Th 1.8

- Top panels, bottom panels, movable shelves, back panels and central side panels in Leather grey (LG7H) finish.
- For assembly, at least an extra 4 cm in width is required.
- In overhead wardrobes W 300 and wardrobes with console, the shelves are fixed to the side of the wardrobe from the inside with visible screws.
- The wardrobe with TV mount must always be between two wardrobes (one on the Right and one on the Left).
- The doors of the overhead module, niche, console and bottom doors of the TV stand module are without handles and open with a 16 mm protrusion on the vault or on the shelf.

### IMPORTANT!

- **Internal fittings supplied consist in:** 1 clothes hanging bar in line with doors Ht 128; 2 clothes hanging bars in line with doors Ht 224, 240 and 256;
- 1 movable shelf in line with doors Ht 80 and 96.
- **Size reductions in height are permitted.**

### Overhead wardrobe W 300

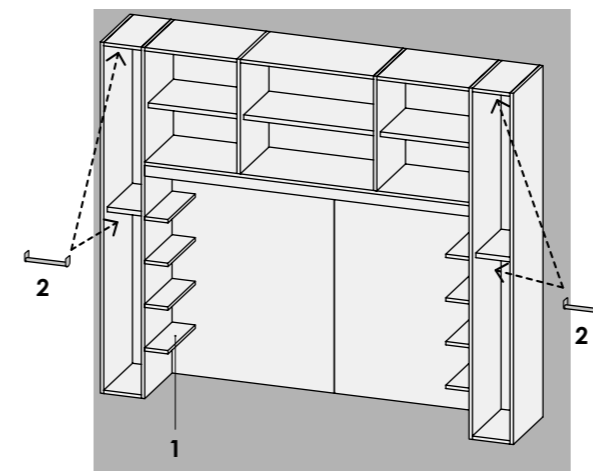

- 1 Shelf Th 2.5
- 2 PLUS clothes hanging bar
- 3 Console Th 6

### Wardrobe with niche

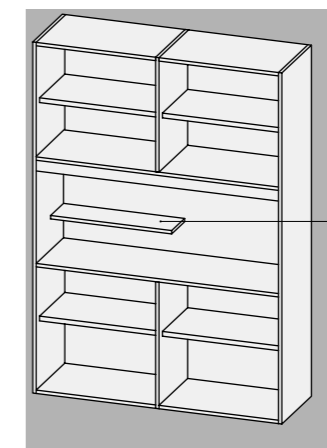

### Wardrobe with console

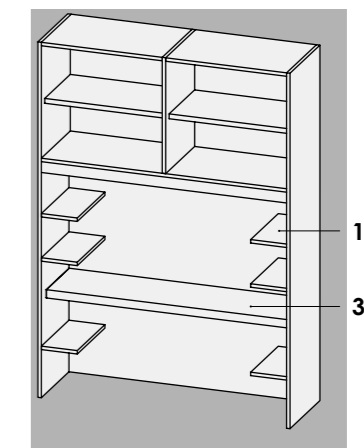

### Wardrobe with TV mount

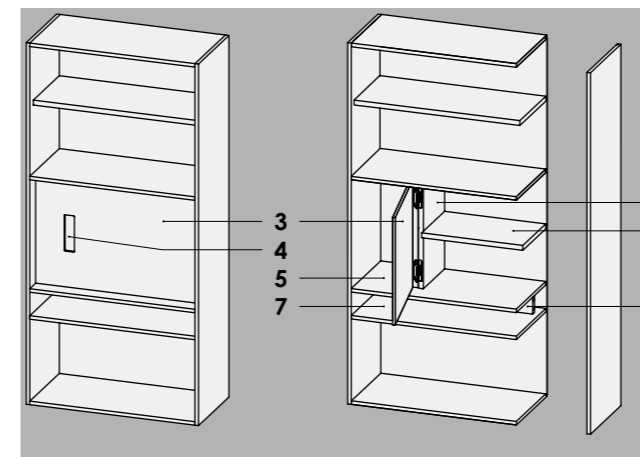

- 1 Inner side Th 3.5
- 2 Shelf Th 3.5 - W 72
- 3 TV back panel Th 1.8
- 4 Cable grommet hole
- 5 Bottom panel Th 2.5
- 6 Chain Th 3.5
- 7 Shelf Th 2.5

# Overhead wardrobes compositions

# Wardrobes with niche

Ht 241.8

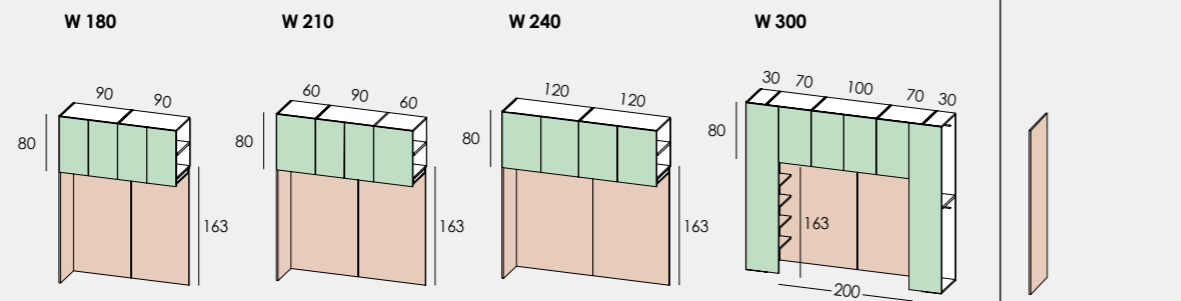

End side panel  
Th 2.5

Code	PV14.10E	PV14.11M	PV14.12T	PV14.13Z	PV14.00Z
CONCRETA	Th 2.5				

Ht 257.8

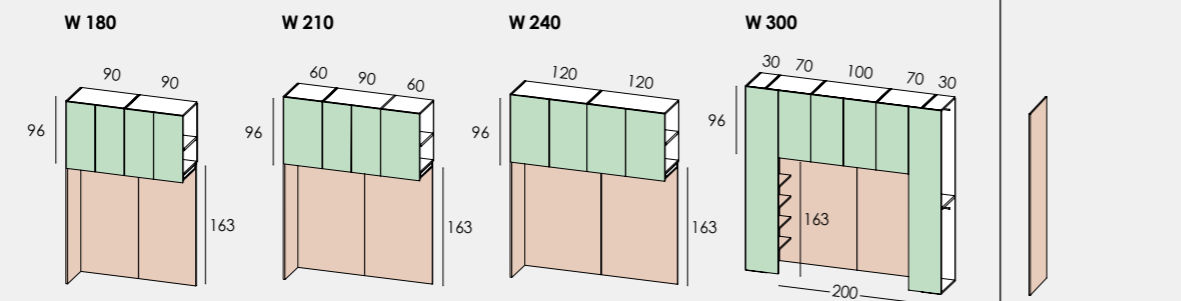

Code	PV14.20L	PV14.22Y	PV14.24M	PV14.26Z	PV14.01F
CONCRETA	Th 2.5				

Ht 257.8

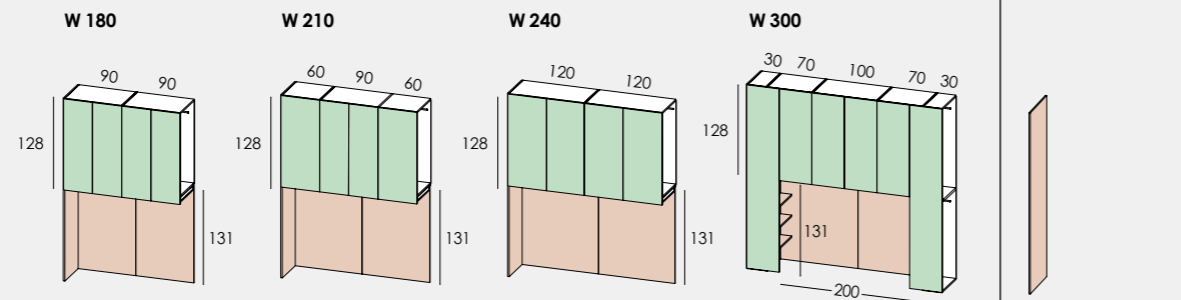

Code	PV14.21S	PV14.23E	PV14.25T	PV14.27F	PV14.01F
CONCRETA	Th 2.5				

**Lighting kit**

For compartment from 150 to 180



For compartment from 200 to 240



**Shelf optional**

Generates specific drilling on the side panel

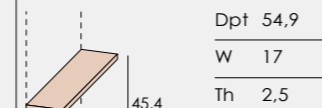

Code	PV14.02N	PV14.03U	PV14.04A
------	----------	----------	----------

- Components in **CARCASE** colors
- Components in **GROUP 3** colors
- Components in **Types and colors FRONT**

Ht 241.8

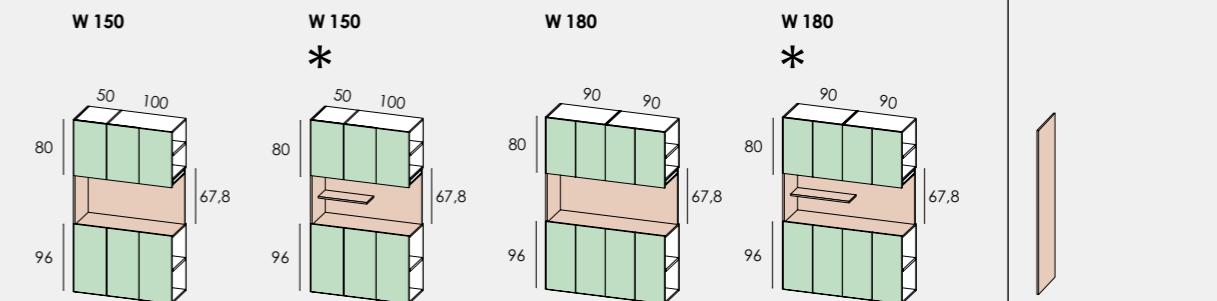

End side panel  
Th 2.5

Code	PV14.31X	PV14.30R	PV14.33L	PV14.32D	PV14.00Z
CONCRETA	Th 2.5				

Ht 257.8

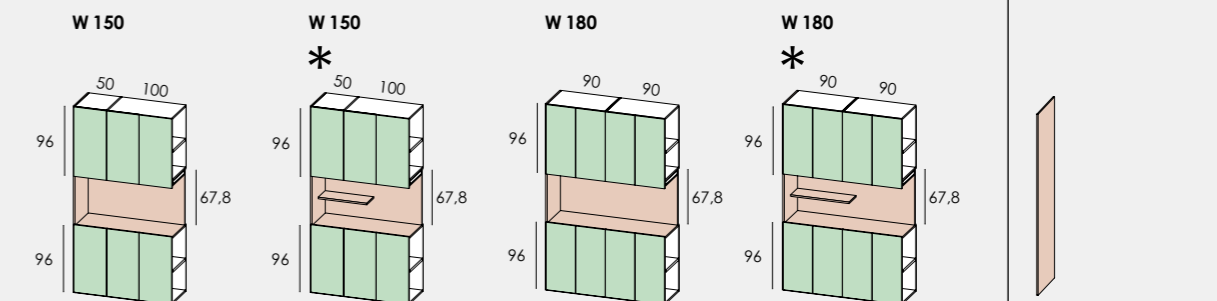

Code	PV14.41C	PV14.40W	PV14.43R	PV14.42K	PV14.01F
CONCRETA	Th 2.5				

**Lighting kit**

For compartment from 150 to 180

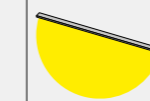

Code	PV14.02N
------	----------

\* During assembly the shelf can be positioned on the Right or Left.

## Wardrobes with console

Ht 241.8

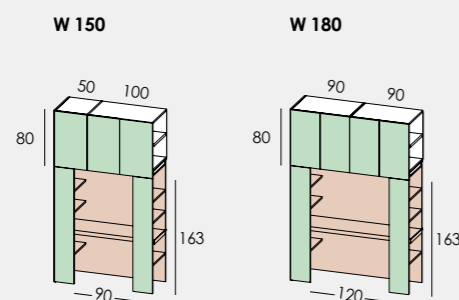

<b>Code</b>	<b>PV14.34S</b>	<b>PV14.35Y</b>		<b>PV14.00Z</b>
CONCRETA Th 2.5				

Ht 257.8

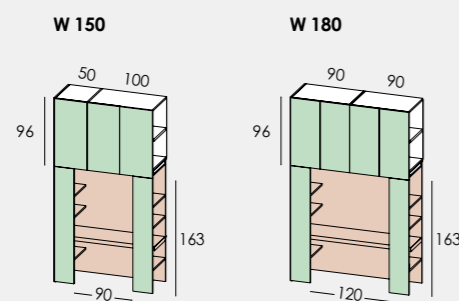

<b>Code</b>	<b>PV14.44X</b>	<b>PV14.45D</b>		<b>PV14.01F</b>
CONCRETA Th 2.5				

End side panel  
Th 2.5



<b>Code</b>	<b>PV14.02N</b>		

- Components in **CARCASE** colors
- Components in **GROUP 3** colors
- Components in **Types and colors FRONT**

## Wardrobes with TV mount

They must always be placed side by side, both on the right and on the left, with another module.

Ht 241.8

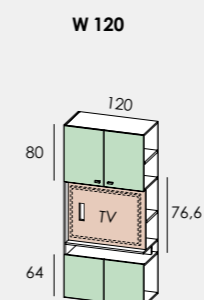

<b>Code</b>	<b>PV14.36E</b>			
CONCRETA Th 2.5				

Ht 257.8

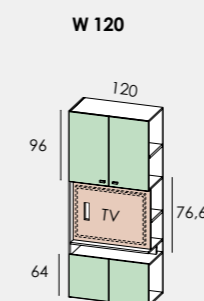

<b>Code</b>	<b>PV14.46L</b>			
CONCRETA Th 2.5				

<b>Code</b>	<b>PV14.05G</b>		

Optional rectangular cable grommet, in black.

Recommended for televisions smaller than 32"

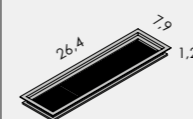

TV compartment space

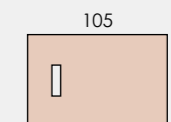

Colour correspondence key

**CARCASE color**

Leather grey  
**LG7H**

**GROUP 3 colors**

Rovere white <b>RW3Q</b>	Rovere Dorian <b>RD5T</b>	Ciliegio bianco <b>CB6K</b>	Noce naturale <b>NN7H</b>	Noce <b>NC4B</b>	Eucalipto <b>CL1X</b>	Malta <b>ML7H</b>
Feltro <b>FL8X</b>	Cemento Masdar <b>CM3Q</b>	Bianco opaco <b>BI7A</b>	Desert <b>DS9L</b>	Canapa <b>CN1X</b>	Moka <b>MK6B</b>	Grigio Dorian <b>GL4R</b>
Basalto <b>BS5T</b>	Grigio titanio <b>GZ8T</b>	Agave <b>GV7A</b>	Verde Alpi <b>VA5T</b>	Cadaques <b>CQ3Q</b>	Blu opale <b>BO7H</b>	

**Types and colors FRONT**

<b>STYLE</b> Th 1.8	<b>A</b>	Rovere white <b>RW3Q</b>	Rovere Dorian <b>RD5T</b>	Ciliegio bianco <b>CB6K</b>	Noce naturale <b>NN7H</b>	Noce <b>NC4B</b>	Eucalipto <b>CL1X</b>	Malta <b>ML7H</b>
<b>MOSAICO</b> Th 1.8	<b>A</b>	Feltro <b>FL8X</b>	Cemento Masdar <b>CM3Q</b>	Bianco opaco <b>BI7A</b>	Desert <b>DS9L</b>	Canapa <b>CN1X</b>	Moka <b>MK6B</b>	Grigio Dorian <b>GL4R</b>
<b>FREEDOM</b> Th 1.8	<b>B</b>	Basalto <b>BS5T</b>	Grigio titanio <b>GZ8T</b>	Agave <b>GV7A</b>	Verde Alpi <b>VA5T</b>	Cadaques <b>CQ3Q</b>	Blu opale <b>BO7H</b>	
<b>CONCRETA</b> Th 2.5	<input checked="" type="checkbox"/>	Specify the color of the long side handle						
<b>RAIL</b> Th 2.5/1.8	<b>B</b>	Rovere white <b>RW3Q</b>	Rovere Dorian <b>RD5T</b>	Ciliegio bianco <b>CB6K</b>	Noce naturale <b>NN7H</b>	Bianco opaco <b>BI7A</b>	Desert <b>DS9L</b>	Canapa <b>CN1X</b>
<b>CUTTING</b> Th 2.5	<b>C</b>	Noce <b>NC4B</b>	Eucalipto <b>CL1X</b>	Malta <b>ML7H</b>	Feltro <b>FL8X</b>	Moka <b>MK6B</b>	Grigio Dorian <b>GL4R</b>	Basalto <b>BS5T</b>
		Cemento Masdar <b>CM3Q</b>	Bianco opaco <b>BI7A</b>	Desert <b>DS9L</b>	Canapa <b>CN1X</b>	Grigio titanio <b>GZ8T</b>	Agave <b>GV7A</b>	Verde Alpi <b>VA5T</b>
		Moka <b>MK6B</b>	Grigio Dorian <b>GL4R</b>	Basalto <b>BS5T</b>	Grigio titanio <b>GZ8T</b>	Cadaques <b>CQ3Q</b>	Blu opale <b>BO7H</b>	
		Agave <b>GV7A</b>	Verde Alpi <b>VA5T</b>	Cadaques <b>CQ3Q</b>	Blu opale <b>BO7H</b>			

The internal insert is available in all front colors

**Modular wardrobes - Sliding doors**

Wardrobes with sliding doors - technical information	536
Wardrobes with STYLE sliding doors Th 1.8	538
Wardrobes with MOSAICO sliding doors Th 1.8	544
Wardrobes with FREEDOM sliding doors Th 1.8	548
Wardrobes with CONCRETA sliding doors Th 2.5	550
Wardrobes with RAIL sliding doors Th 1.8/2.5	552
Wardrobes with CUTTING sliding doors Th 2.5	554

# Wardrobes with sliding doors - technical information

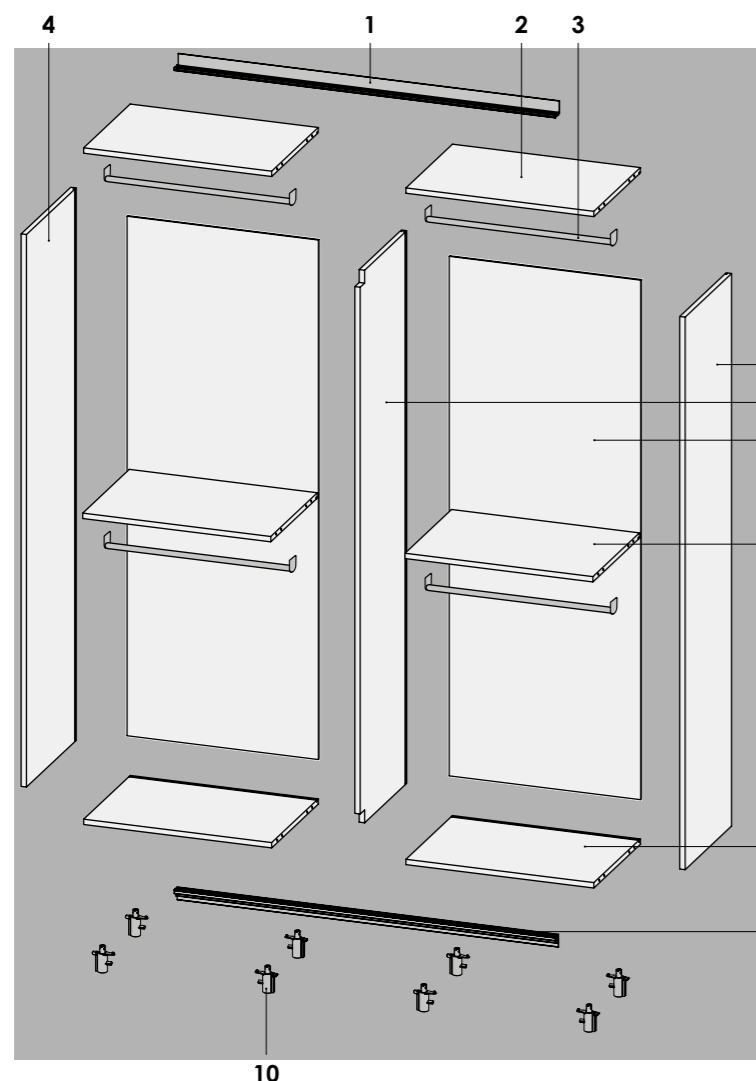

## Components:

- 1 Upper sliding rail
- 2 Top panel Th 2.5
- 3 PLUS clothes hanging bar in aluminum.
- 4 Side panels Th 2.5
- 5 Central side panel Th 2.5
- 6 Back panel Th 0.8 - Fitting into shaped connection.
- 7 Movable shelf Th 3.5
- 8 Bottom panel Th 2.5 - With eccentric pin system
- 9 Lower sliding rail
- 10 Adjustable feet

## Dimensions:

**W** 182,5 - 202,5 - 272,5 - 302,5  
362,5 - 402,5 - 407,5

**Dpt** 66,4      67,5  
CONCRETA      STYLE  
CUTTING      MOSAICO  
                    FREEDOM  
                    RAIL

**Ht** 225,8 - 241,8 - 257,8 - 289,8

- Tops are not finished.
- The wardrobes can be placed side by side.
- Top panels, bottom panels, movable shelves, back panels and central side panels in Leather grey (LG7H) finish.
- Fitted with a soft opening/closing system.
- For assembly, an extra 4 cm in width and 8 cm in height is required; for correct sliding in a niche, at least an extra 4 cm in height is required (if the "kit for assembly in niche" Code PV00.58H" is ordered, 2 cm in width are sufficient).

## IMPORTANT!

- The mirror Th 0.4 is applied on a white melamine-coated panel Th 1.4.
- **Internal fittings supplied for every niche:** 2 clothes hanging bars and 1 melamine-coated movable shelf.
- **For custom cuts consult the relevant chapter.**
- We recommend fixing them to the wall with the provided hardware; if the depth has been reduced, they must be anchored to the wall.

## Widths and opening diagram

When ordering two-door wardrobes, you must specify if the protruding door is L or R.  
The side panel next to the protruding door is 63.1/63.5 cm deep while the side panel next to the non-protruding door is 59.5 cm deep.

### Wardrobe with 2 doors L

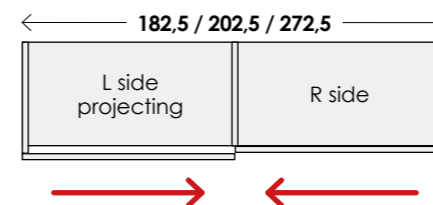

### Wardrobe with 2 doors R

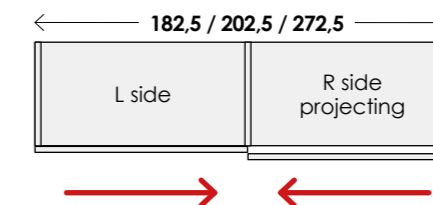

### Wardrobe with 2 doors L

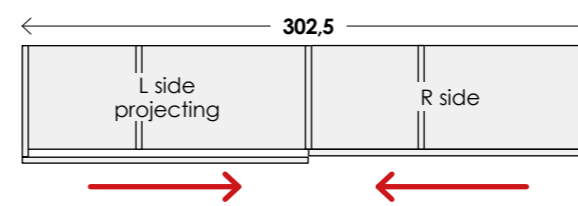

### Wardrobe with 2 doors R

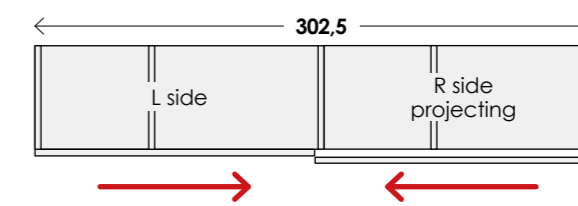

The positioning of the W 60 / W 90 compartments can be established during assembly.

### Wardrobe with 3 doors

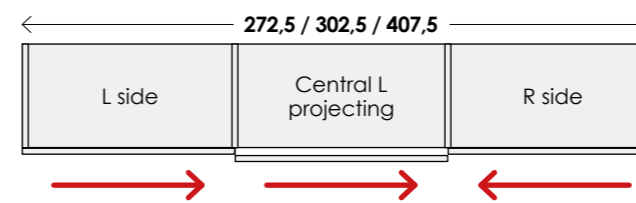

### Wardrobe with 4 doors

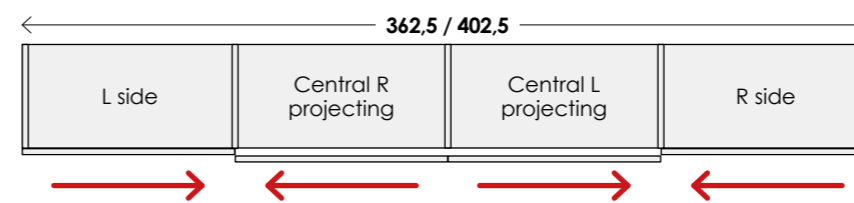



# Wardrobes with STYLE sliding doors Th 1.8

## Ht 225.8

In wardrobes with two compartments, indicate R or L protruding door

W 182,5

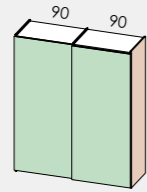

W 202,5

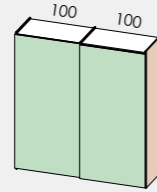

W 272,5

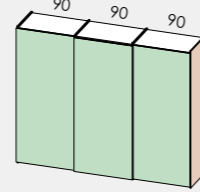

W 302,5

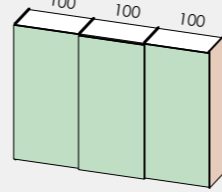

W 362,5

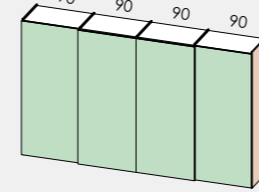

W 402,5

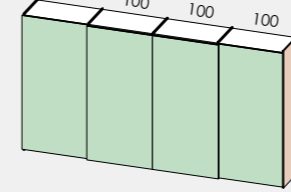

Code	PV15.10K	PV15.15S	PV15.20Q	PV15.27L	PV15.36K	PV15.41G			
------	----------	----------	----------	----------	----------	----------	--	--	--

## Ht 241.8

In wardrobes with two compartments, indicate R or L protruding door

W 182,5

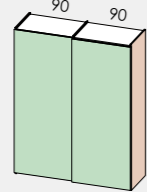

W 202,5

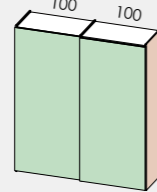

W 272,5

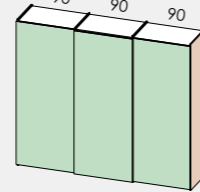

W 302,5

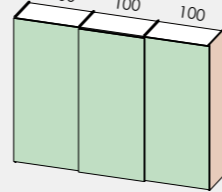

W 362,5

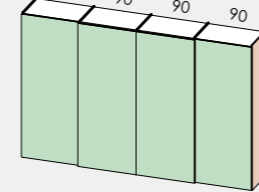

W 402,5

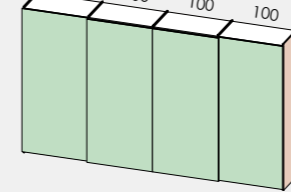

Code	PV15.50F	PV15.54G	PV15.58H	PV15.63F	PV15.67G	PV15.71Y			
------	----------	----------	----------	----------	----------	----------	--	--	--

## Ht 257.8

In wardrobes with two compartments, indicate R or L protruding door

W 182,5

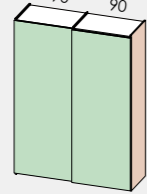

W 202,5

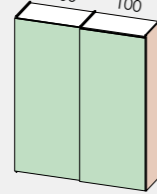

W 272,5

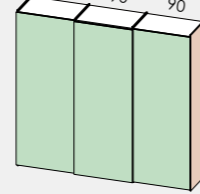

W 302,5

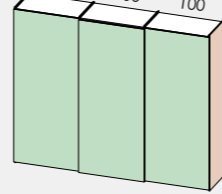

W 362,5

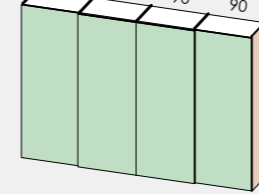

W 402,5

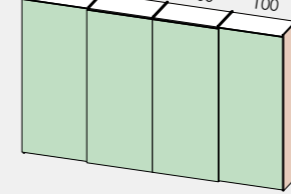

Code	PV15.80X	PV15.91K	PV16.02W	PV16.20U	PV16.34A	PV16.43Z			
------	----------	----------	----------	----------	----------	----------	--	--	--

- Components in **CARCASE** colors
- Components in **GROUP 3** colors
- Components in **Types and colors FRONT**



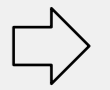

# Wardrobes with STYLE sliding doors Th 1.8

## Ht 225.8

In wardrobes with two compartments, indicate R or L protruding door

W 182,5

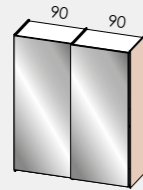

W 202,5

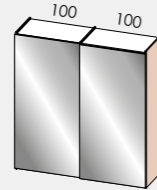

W 272,5

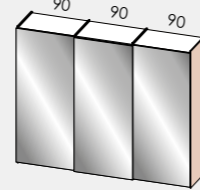

W 302,5

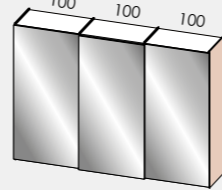

W 362,5

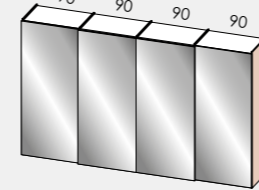

W 402,5

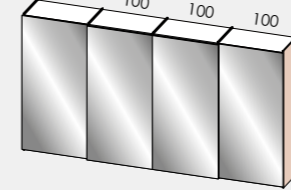

Code	PV17.00N	PV17.01U	PV17.02A	PV17.03G	PV17.12F	PV17.13N			
------	----------	----------	----------	----------	----------	----------	--	--	--

## Ht 241.8

In wardrobes with two compartments, indicate R or L protruding door

W 182,5

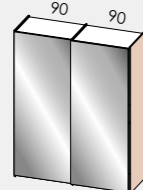

W 202,5

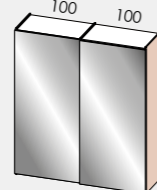

W 272,5

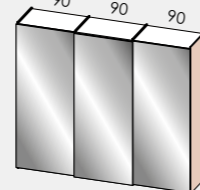

W 302,5

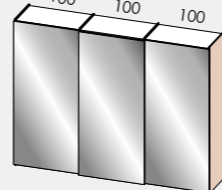

W 362,5

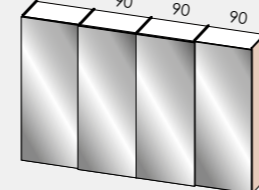

W 402,5

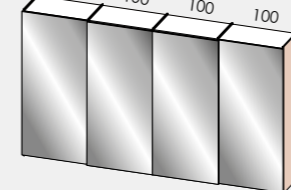

Code	PV17.04P	PV17.05V	PV17.06B	PV17.07H	PV17.14U	PV17.15A			
------	----------	----------	----------	----------	----------	----------	--	--	--

## Ht 257.8

In wardrobes with two compartments, indicate R or L protruding door

W 182,5

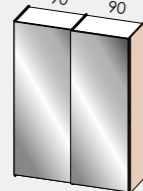

W 202,5

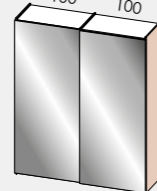

W 272,5

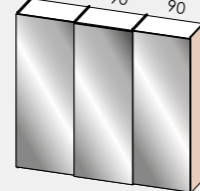

W 302,5

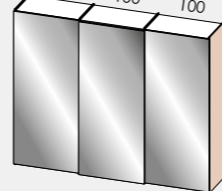

W 362,5

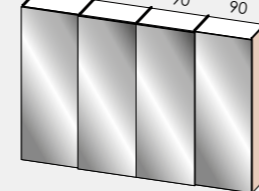

W 402,5

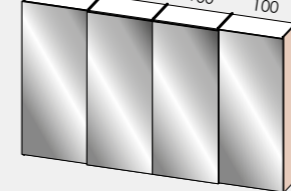

Code	PV17.08Q	PV17.09W	PV17.10T	PV17.11Z	PV17.16G	PV17.17P			
------	----------	----------	----------	----------	----------	----------	--	--	--

- Components in **CARCASE** colors
- Components in **GROUP 3** colors
- Mirror

# Wardrobes with STYLE sliding doors Th 1.8

## Ht 225.8

In wardrobes with two compartments, indicate R or L protruding door

W 182,5

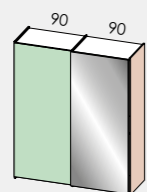

W 202,5

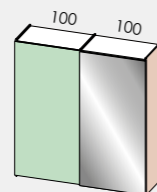

W 272,5

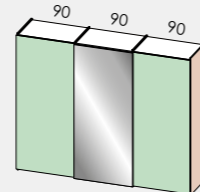

W 302,5

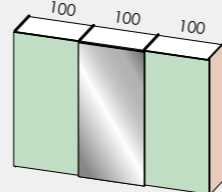

W 362,5

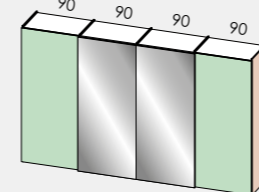

W 402,5

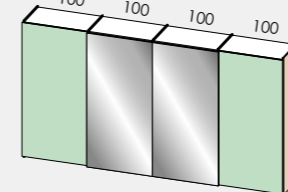

<b>Code</b>	<b>PV15.11R</b>	<b>PV15.16Y</b>	<b>PV15.21W</b>	<b>PV15.28S</b>	<b>PV15.37R</b>	<b>PV15.42P</b>			
-------------	-----------------	-----------------	-----------------	-----------------	-----------------	-----------------	--	--	--

## Ht 241.8

In wardrobes with two compartments, indicate R or L protruding door

W 182,5

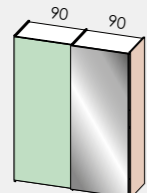

W 202,5

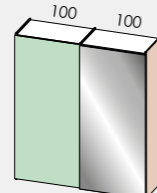

W 272,5

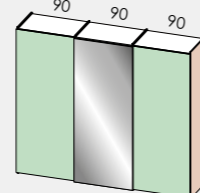

W 302,5

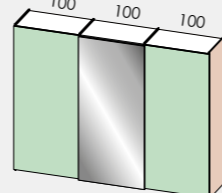

W 362,5

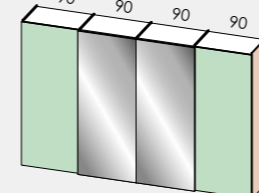

W 402,5

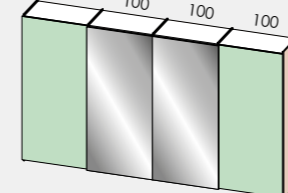

<b>Code</b>	<b>PV15.51N</b>	<b>PV15.55P</b>	<b>PV15.59Q</b>	<b>PV15.64N</b>	<b>PV15.68P</b>	<b>PV15.72E</b>			
-------------	-----------------	-----------------	-----------------	-----------------	-----------------	-----------------	--	--	--

## Ht 257.8

In wardrobes with two compartments, indicate R or L protruding door

W 182,5

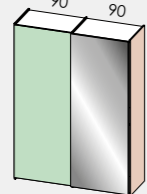

W 202,5

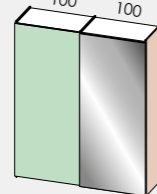

W 272,5

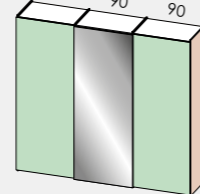

W 302,5

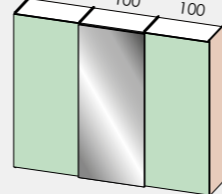

W 362,5

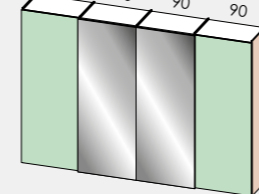

W 402,5

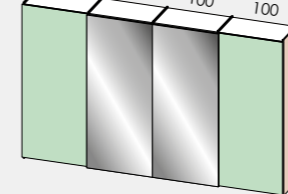

<b>Code</b>	<b>PV15.81D</b>	<b>PV15.92R</b>	<b>PV16.03C</b>	<b>PV16.21A</b>	<b>PV16.35G</b>	<b>PV16.44F</b>			
-------------	-----------------	-----------------	-----------------	-----------------	-----------------	-----------------	--	--	--

- Components in **CARCASE** colors
- Components in **GROUP 3** colors
- Components in **Types and colors FRONT**
- Mirror



# Wardrobes with MOSAICO sliding doors Th 1.8

## Ht 257.8

In wardrobes with two compartments, indicate R or L protruding door

W 182,5

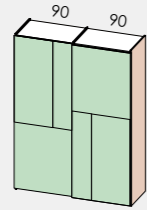

W 182,5

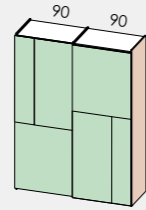

W 202,5

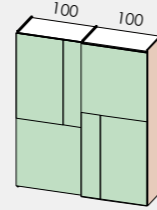

W 202,5

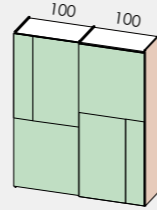

W 272,5

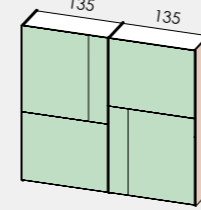

W 272,5

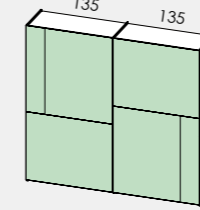

W 272,5

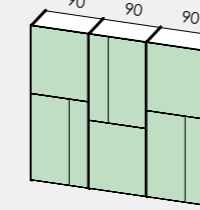

W 272,5

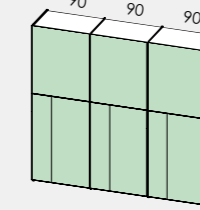

W 302,5

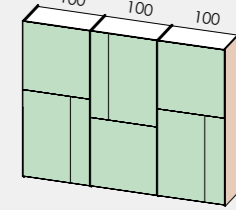

Code	PV15.82L	PV15.83S	PV15.93X	PV15.94D	PV16.04K	PV16.05R	PV16.06X	PV16.07D	PV16.22G
------	----------	----------	----------	----------	----------	----------	----------	----------	----------

## Ht 257.8

W 302,5

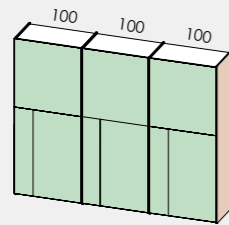

W 362,5

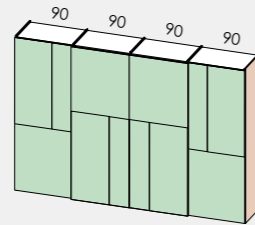

W 362,5

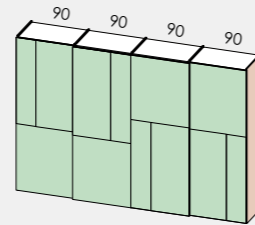

W 402,5

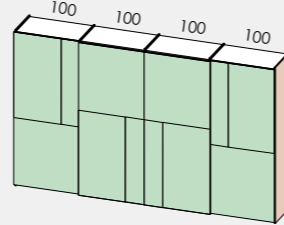

W 402,5

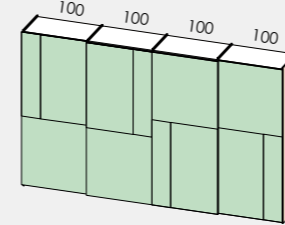

W 407,5

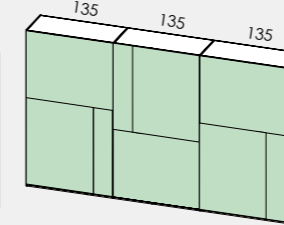

W 407,5

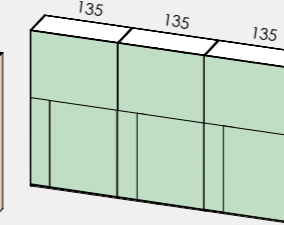

Code	PV16.23P	PV16.36P	PV16.37V	PV16.45N	PV16.46U	PV16.52Y	PV16.53E		
------	----------	----------	----------	----------	----------	----------	----------	--	--

- Components in **CARCASE** colors
- Components in **GROUP 3** colors
- Components in **Types and colors FRONT**

# Wardrobes with MOSAICO sliding doors Th 1.8

## Ht 257.8

In wardrobes with two compartments, indicate R or L protruding door

W 182,5

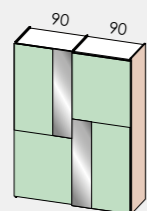

W 182,5

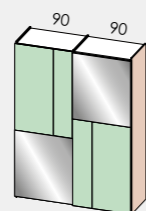

W 182,5

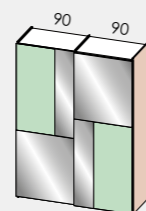

W 182,5

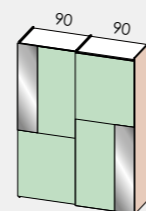

W 202,5

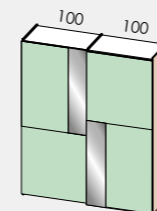

W 202,5

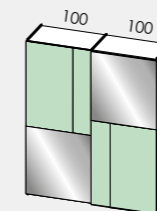

W 202,5

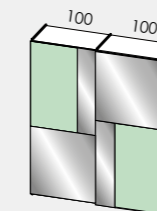

W 202,5

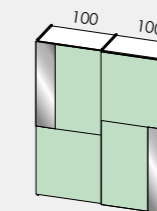

W 272,5

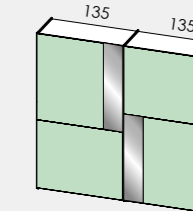

Code	PV15.84Y	PV15.85E	PV15.86M	PV15.87T	PV15.95L	PV15.96S	PV15.97Y	PV15.98E	PV16.08L
------	----------	----------	----------	----------	----------	----------	----------	----------	----------

## Ht 257.8

In wardrobes with two compartments, indicate R or L protruding door

W 272,5

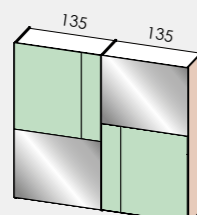

W 272,5

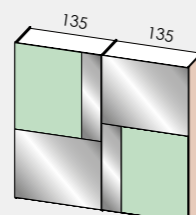

W 272,5

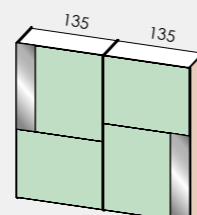

W 272,5

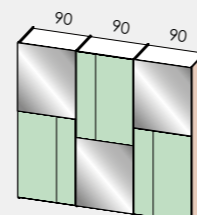

W 272,5

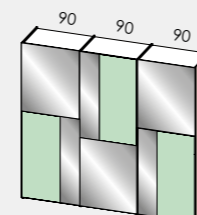

W 272,5

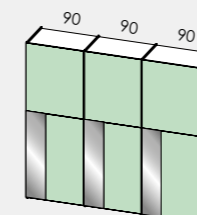

W 302,5

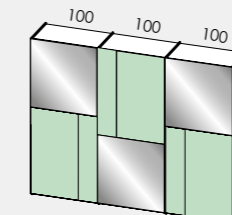

W 302,5

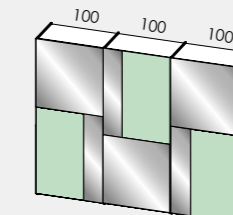

W 302,5

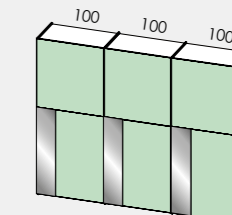

Code	PV16.09S	PV16.10P	PV16.11V	PV16.12B	PV16.13H	PV16.14Q	PV16.24V	PV16.25B	PV16.26H
------	----------	----------	----------	----------	----------	----------	----------	----------	----------

## Ht 257.8

W 362,5

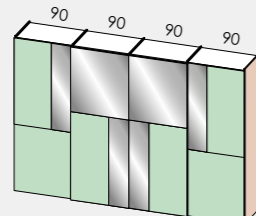

W 362,5

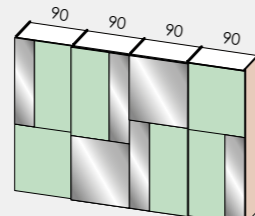

W 402,5

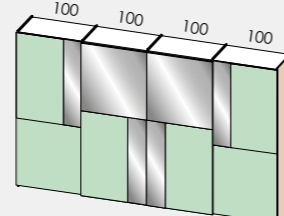

W 402,5

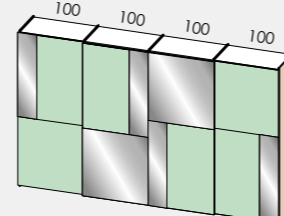

W 407,5

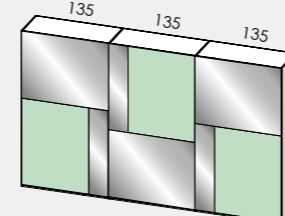

W 407,5

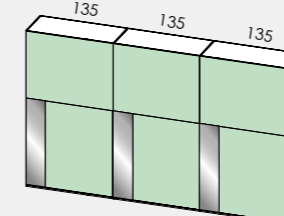

Code	PV16.38B	PV16.39H	PV16.47A	PV16.48G	PV16.54M	PV16.55T			
------	----------	----------	----------	----------	----------	----------	--	--	--

- Components in **CARCASE** colors
- Components in **GROUP 3** colors
- Components in **Types and colors FRONT**
- Mirror

# Wardrobes with FREEDOM sliding doors Th 1.8

## Ht 225.8

Indicate R or L protruding door

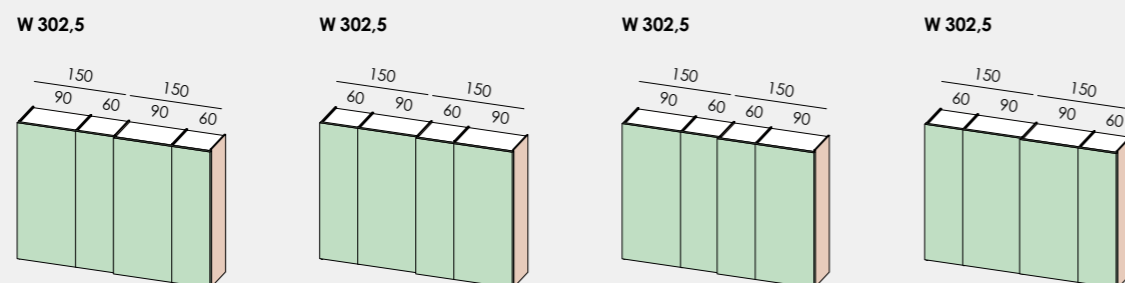

<b>Code</b>	<b>PV15.29Y</b>	<b>PV15.30V</b>	<b>PV15.31B</b>	<b>PV15.32H</b>					
-------------	-----------------	-----------------	-----------------	-----------------	--	--	--	--	--

## Ht 257.8

Indicate R or L protruding door

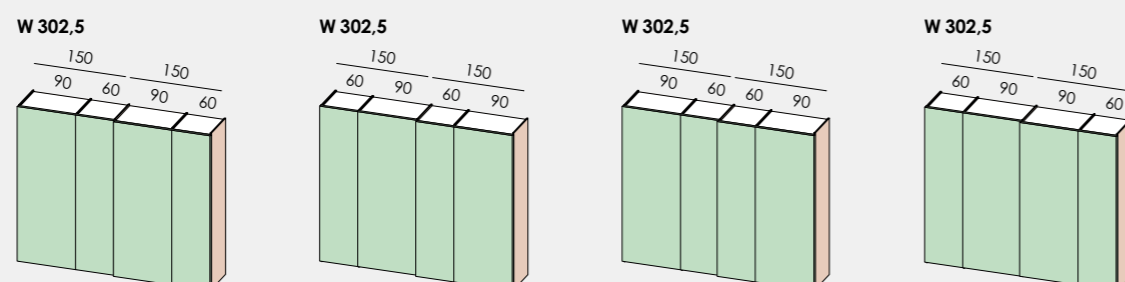

<b>Code</b>	<b>PV16.27Q</b>	<b>PV16.28W</b>	<b>PV16.29C</b>	<b>PV16.30Z</b>					
-------------	-----------------	-----------------	-----------------	-----------------	--	--	--	--	--

- Components in **CARCASE colors**
- Components in **GROUP 3 colors**
- Components in **Types and colors FRONT**

The positioning of the W 60 / W 90 compartments can be established during assembly.

# Wardrobes with CONCRETA sliding doors Th 2.5

## Ht 225.8

In wardrobes with two compartments, indicate R or L protruding door

W 182,5

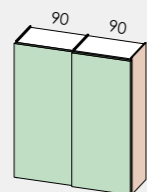

W 202,5

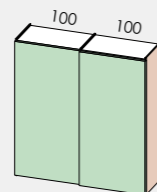

W 272,5

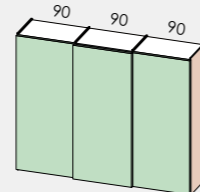

W 302,5

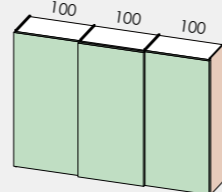

W 362,5 \*

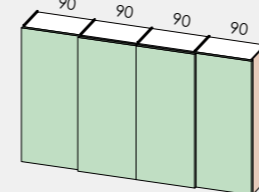

W 402,5 \*

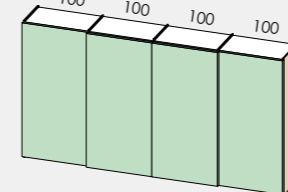

Code	PV15.12X	PV15.17E	PV15.22C	PV15.33Q	PV15.38X	PV15.43V			
------	----------	----------	----------	----------	----------	----------	--	--	--

## Ht 241.8

In wardrobes with two compartments, indicate R or L protruding door

W 182,5

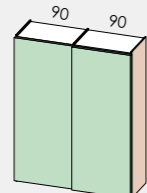

W 202,5

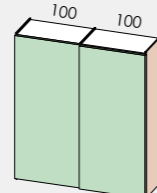

W 272,5

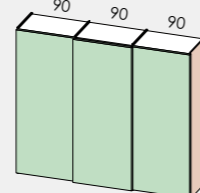

W 302,5

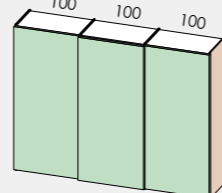

W 362,5 \*

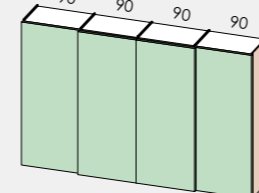

W 402,5 \*

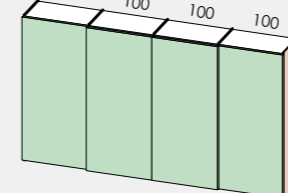

Code	PV15.52U	PV15.56V	PV15.60M	PV15.65U	PV15.69V	PV15.73M			
------	----------	----------	----------	----------	----------	----------	--	--	--

## Ht 257.8

In wardrobes with two compartments, indicate R or L protruding door

W 182,5

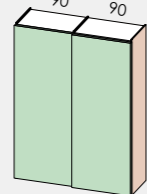

W 202,5

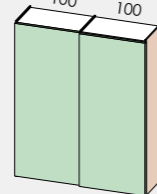

W 272,5

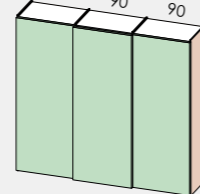

W 302,5

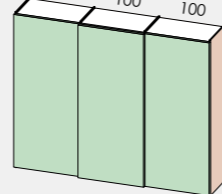

W 362,5 \*

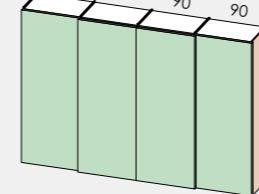

W 402,5 \*

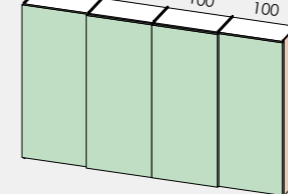

Code	PV15.88Z	PV15.99M	PV16.15W	PV16.31F	PV16.40E	PV16.49P			
------	----------	----------	----------	----------	----------	----------	--	--	--

## Ht 289.8

In wardrobes with two compartments, indicate R or L protruding door

W 182,5

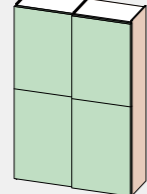

W 202,5

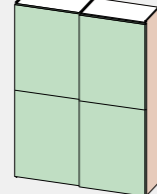

W 272,5

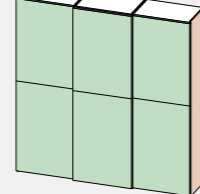

W 302,5

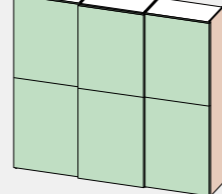

W 362,5 \*

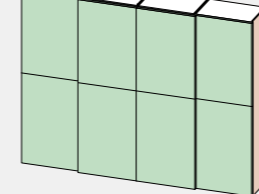

W 402,5 \*

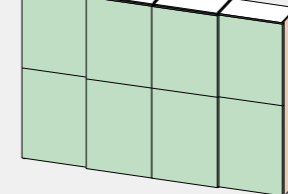

Code	PV16.58N	PV16.59U	PV16.60R	PV16.61X	PV16.62D	PV16.63L			
------	----------	----------	----------	----------	----------	----------	--	--	--

□ Components in **CARCASE** colors

■ Components in **GROUP 3** colors

■ Components in **Types and colors FRONT**

\* Central doors must have a handle (not G90U).



# Wardrobes with RAIL sliding doors Th 1.8/2.5

## Ht 225.8

In wardrobes with two compartments, indicate R or L protruding door

W 182,5

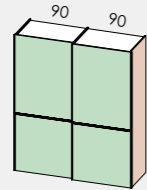

W 202,5

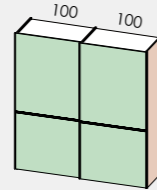

W 272,5

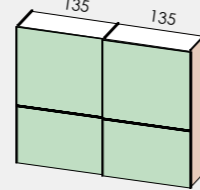

W 272,5

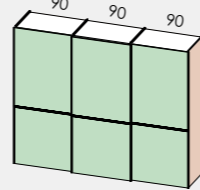

W 302,5

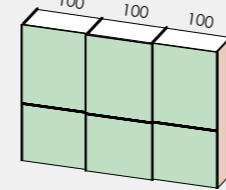

W 362,5

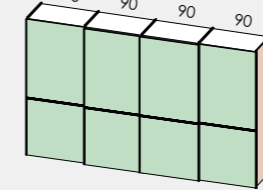

W 402,5

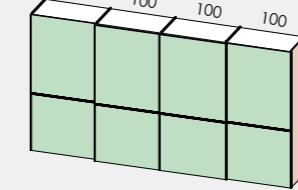

W 407,5

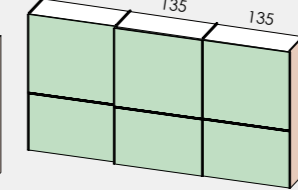

Code	PV15.13D	PV15.18M	PV15.23K	PV15.24R	PV15.34W	PV15.39D	PV15.44B	PV15.46Q
Without light								
With light								

## Ht 257.8

In wardrobes with two compartments, indicate R or L protruding door

W 182,5

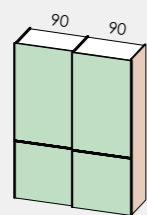

W 202,5

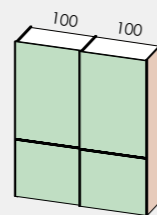

W 272,5

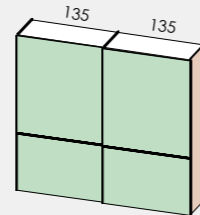

W 272,5

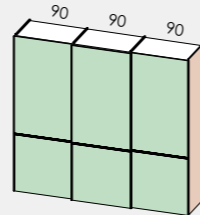

W 302,5

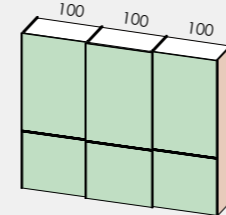

W 362,5

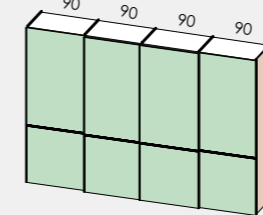

W 402,5

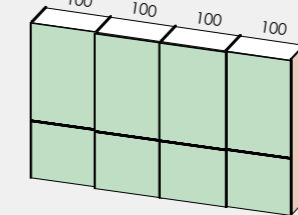

W 407,5

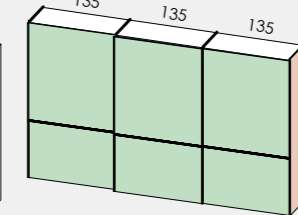

Code	PV15.89F	PV16.00H	PV16.16C	PV16.17K	PV16.32N	PV16.41M	PV16.50L	PV16.56Z
Without light								
With light								

### Wireless switches

#### Remote control

The remote control is a wireless switch (single channel or multi-channel) using which it is possible to turn on, off, and regulate the brightness of the led profiles connected to the receiving power adapter.



#### Bluetooth application board

The remote control module activates the Bluetooth function that allows you to manage the lights from your smartphone thanks to the dedicated App.



Code	PV00.60M	PV00.59Q

- Components in **CARCASE** colors
- Components in **GROUP 3** colors
- Components in **Types and colors FRONT**

# Wardrobes with CUTTING sliding doors Th 2.5

## Ht 225.8

In wardrobes with two compartments, indicate R or L protruding door

W 182,5

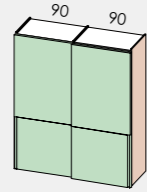

W 202,5

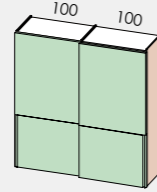

W 272,5

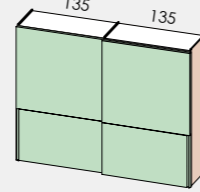

W 272,5

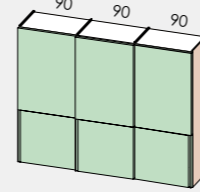

W 302,5

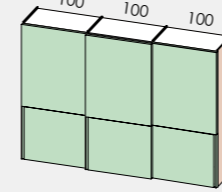

W 362,5

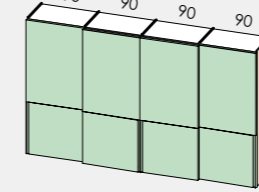

W 402,5

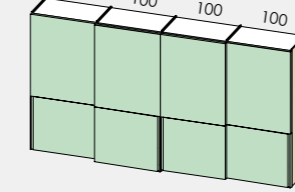

W 407,5

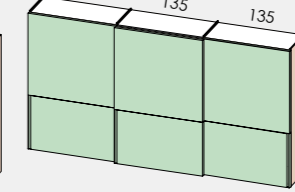

Code	PV15.14L	PV15.19T	PV15.25X	PV15.26D	PV15.35C	PV15.40A	PV15.45H	PV15.47W	
------	----------	----------	----------	----------	----------	----------	----------	----------	--

## Ht 241.8

In wardrobes with two compartments, indicate R or L protruding door

W 182,5

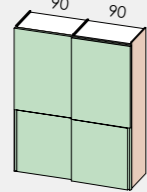

W 202,5

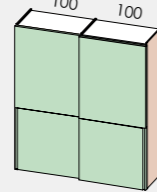

W 272,5

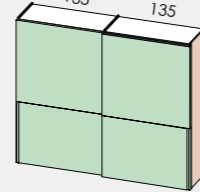

W 272,5

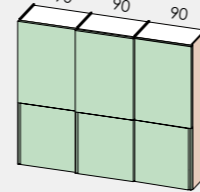

W 302,5

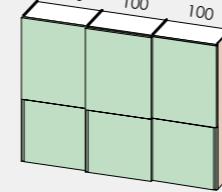

W 362,5

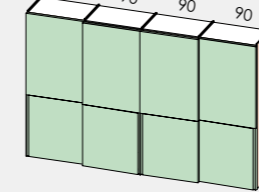

W 402,5

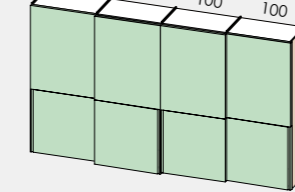

W 407,5

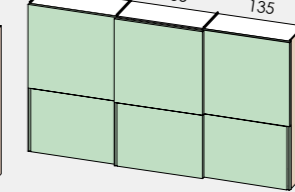

Code	PV15.53A	PV15.57B	PV15.61T	PV15.62Z	PV15.66A	PV15.70S	PV15.74T	PV15.75Z	
------	----------	----------	----------	----------	----------	----------	----------	----------	--

## Ht 257.8

In wardrobes with two compartments, indicate R or L protruding door

W 182,5

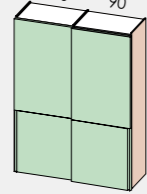

W 202,5

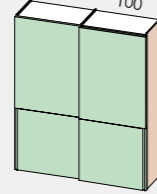

W 272,5

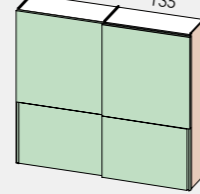

W 272,5

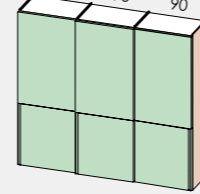

W 302,5

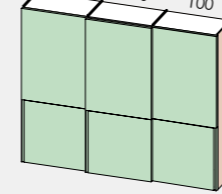

W 362,5

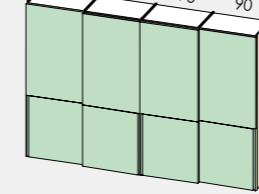

W 402,5

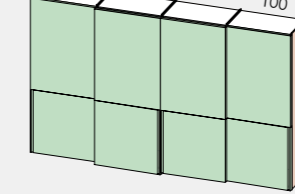

W 407,5

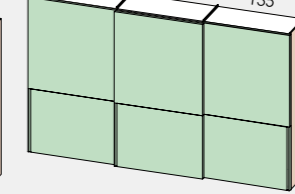

Code	PV15.90C	PV16.01Q	PV16.18R	PV16.19X	PV16.33U	PV16.42T	PV16.51S	PV16.57F	
------	----------	----------	----------	----------	----------	----------	----------	----------	--

- Components in **CARCASE** colors
- Components in **GROUP 3** colors
- Components in **Types and colors FRONT**

Colour correspondence key

**CARCASE color**

Leather grey **LG7H**

**GROUP 3 colors**

Rovere white <b>RW3Q</b>	Rovere Dorian <b>RD5T</b>	Ciliegio bianco <b>CB6K</b>	Noce naturale <b>NN7H</b>	Noce <b>NC4B</b>	Eucalipto <b>CL1X</b>	Malta <b>ML7H</b>
Feltro <b>FL8X</b>	Cemento Masdar <b>CM3Q</b>	Bianco opaco <b>B17A</b>	Desert <b>DS9L</b>	Canapa <b>CN1X</b>	Moka <b>MK6B</b>	Grigio Dorian <b>GL4R</b>
Basalto <b>BS5T</b>	Grigio titanio <b>GZ8T</b>	Agave <b>GV7A</b>	Verde Alpi <b>VA5T</b>	Cadaques <b>CQ3Q</b>	Blu opale <b>BO7H</b>	

Central aluminium frame side colour  
Carbon grey **CG8X**

**Types and colors FRONT**

**STYLE**  
Th 1,8  
matte

glossy

Bianco UV **BU3Q**

**CONCRETA**  
Th 2,5

**CUTTING**  
Th 2,5

**CUTTING PLUS**  
Th 2,5

Rovere white <b>RW3Q</b>	Rovere Dorian <b>RD5T</b>	Ciliegio bianco <b>CB6K</b>	Noce naturale <b>NN7H</b>	Noce <b>NC4B</b>	Eucalipto <b>CL1X</b>	Malta <b>ML7H</b>
Feltro <b>FL8X</b>	Cemento Masdar <b>CM3Q</b>	Bianco opaco <b>B17A</b>	Desert <b>DS9L</b>	Canapa <b>CN1X</b>	Moka <b>MK6B</b>	Grigio Dorian <b>GL4R</b>
Basalto <b>BS5T</b>	Grigio titanio <b>GZ8T</b>	Agave <b>GV7A</b>	Verde Alpi <b>VA5T</b>	Cadaques <b>CQ3Q</b>	Blu opale <b>BO7H</b>	

**Specify the color of the handle (the internal insert is available in all front colors)**

Bianco opaco <b>B17A</b>	Desert <b>DS9L</b>	Canapa <b>CN1X</b>	Moka <b>MK6B</b>	Grigio Dorian <b>GL4R</b>	Basalto <b>BS5T</b>	Grigio titanio <b>GZ8T</b>
Agave <b>GV7A</b>	Verde Alpi <b>VA5T</b>	Cadaques <b>CQ3Q</b>	Blu opale <b>BO7H</b>			

**Modular wardrobes - Walk-in wardrobes**

Walk-in wardrobes - technical information	558
Components for wardrobe room - technical information	559
Central walk-in wardrobes	560
End walk-in wardrobes	562
Modular components for wardrobe room Ht 225.8 Dpt 59.5	564
Modular components for wardrobe room Ht 241.8 Dpt 59.5	565
Modular components for wardrobe room Ht 257.8 Dpt 59.5	566
Modular components for wardrobe room Ht 289.8 Dpt 59.5	567
Central walk-in wardrobes for wardrobe room Dpt 59.5	568
End walk-in wardrobes for wardrobe room Dpt 59.5	570

## Walk-in wardrobes - technical information

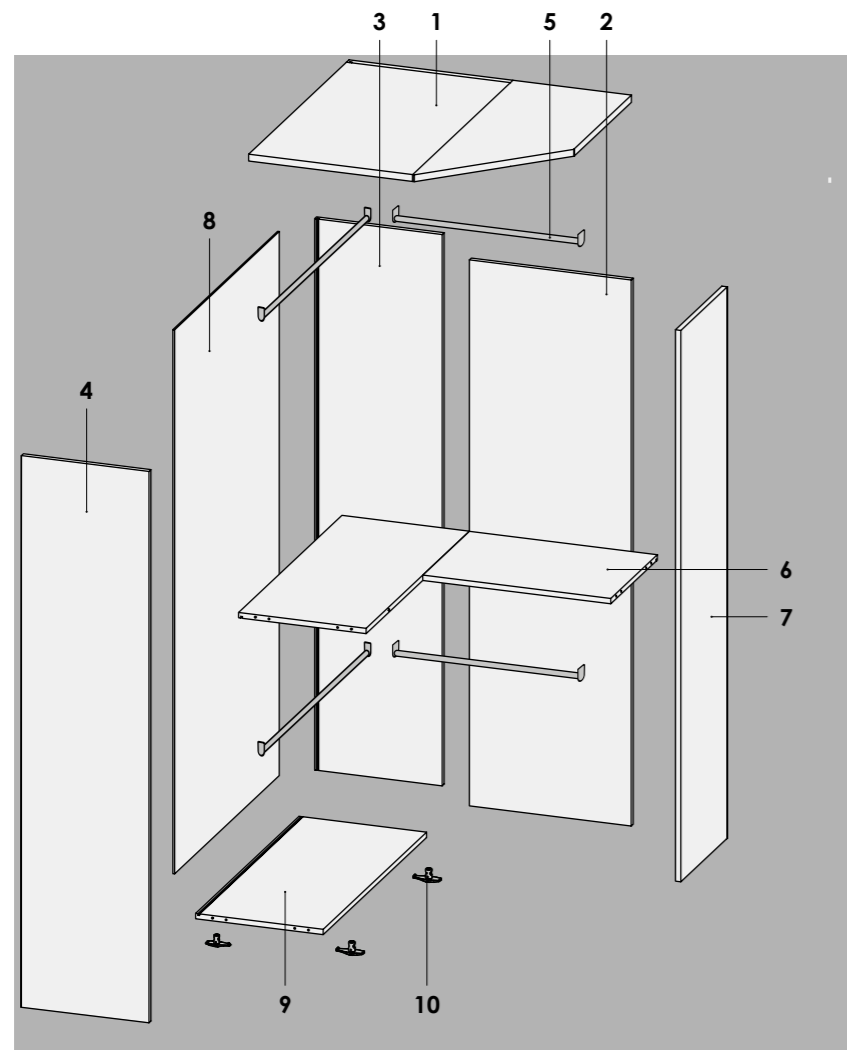

Components:

- 1 Top panel Th 2.5
- 2 Back panel Th 2.5
- 3 Inner side panel Th 2.5
- 4 Central side panel Th 2.5 / lateral for end closets
- 5 PLUS clothes hanging bar in aluminum.
- 6 Movable shelf Th 3.5
- 7 Central side panel Th 2.5
- 8 Back panel Th 0.8 - Fitting into shaped connection.
- 9 Bottom panel Th 2.5
- 10 Adjustable feet

- Top panels, bottom panels, movable shelves, back panels, inner side panel and central side panels in Leather grey (LG7H) finish.
- It is possible to connect the closet to a wardrobe with sliding doors (an image and/or drawing of the composition must be send when placing the order).
- If the door is Th 2.5 or when the closet is flanked by a wardrobe with sliding doors, the central side panels are Th 3.5.
- The central closet must always be combined with two modules, the end closet with one module.
- For assembly, at least an extra 4 cm in width is required (if the "kit for assembly in niche" Code PV00.58H is ordered, 2 cm are sufficient).

### Made-to-measure gap

114,00€ Surcharge for made-to-measure gap (compared to the list price of the element with universal gap).

Always start with the universal gap kit and set the gap size of the pillar.  
To add shelves, they must be indicated with a drawing inside the walk-in wardrobes.

#### Walk-in wardrobe with 2 doors:

70 mm : Minimum gap width  
280 mm : Maximum gap width

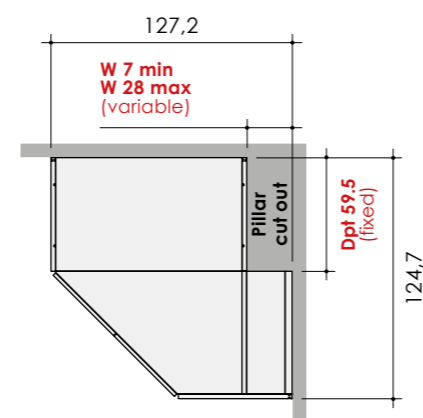
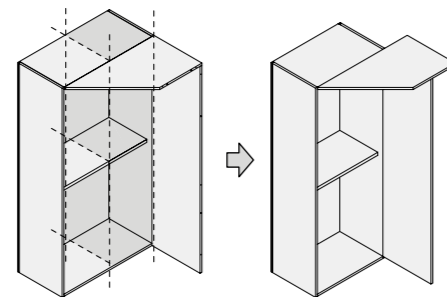

#### Walk-in wardrobe with 1 door:

140 mm : Minimum gap width  
365 mm : Maximum gap width

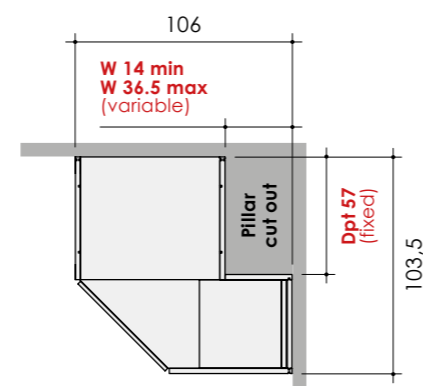
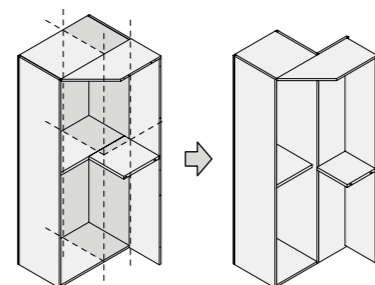

## Components for wardrobe room - technical information

A walk-in composition is obtained by placing open modular modules next to each other (available in the following pages). These modules have the same functional, modular, and dimensional characteristics as those with swing doors and can accommodate all the accessories dedicated to them.  
For more information, see the technical information on wardrobes and walk-ins.

### Example of wardrobe room composition:

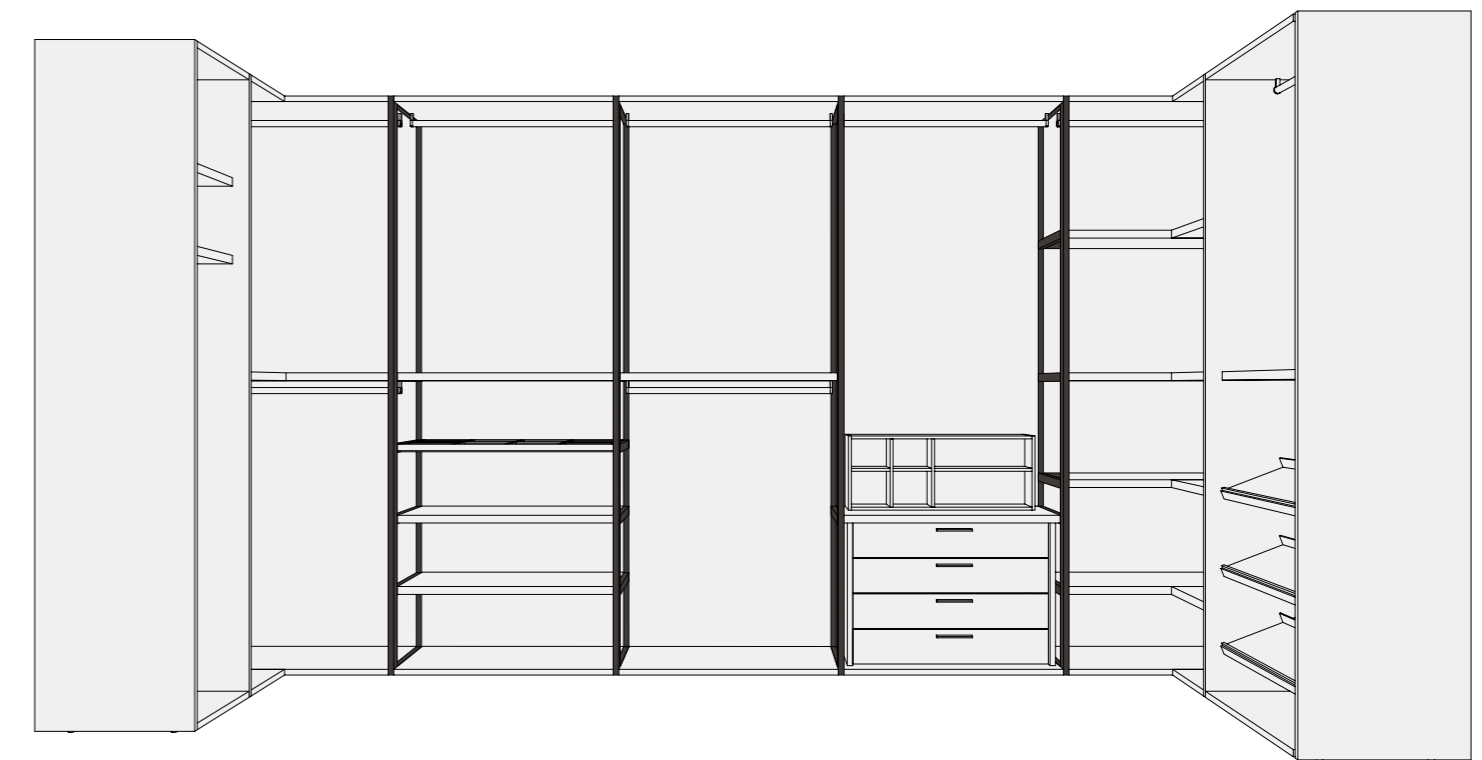

# Central walk-in wardrobes

## Ht 225.8

2 doors W 45

With universal gap

Gap:

Made-to-measure gap:

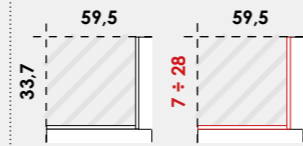

**Gap executable to measure, when ordering indicate the desired size.**  
See technical information at the beginning of the chapter.

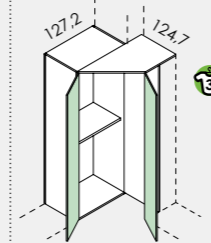
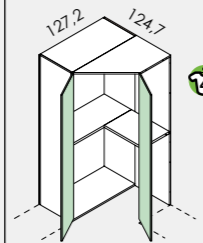

1 door W 60

Specify hinge R or L

With universal gap

Gap:

Made-to-measure gap:

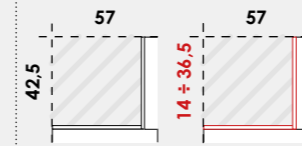

**Gap executable to measure, when ordering indicate the desired size.**  
See technical information at the beginning of the chapter.

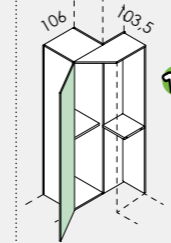
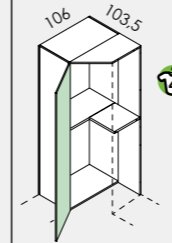

<b>Code</b>	<b>PV18.00S</b>	<b>PV18.01Y</b>		<b>PV18.06F</b>	<b>PV18.07N</b>			
STYLE	Th 1.8	matte glossy						
CONCRETA	Th 2.5							
CUTTING	Th 2.5							
CUTTING PLUS	Th 2.5							

## Ht 241.8

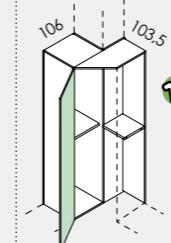
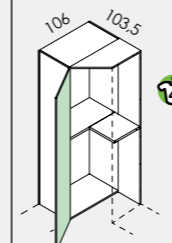
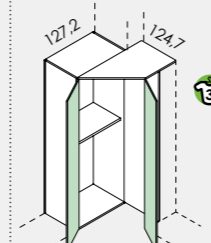
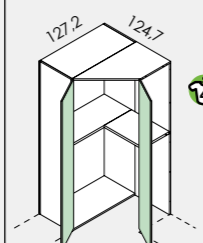

<b>Code</b>	<b>PV18.02R</b>	<b>PV18.03M</b>		<b>PV18.08U</b>	<b>PV18.09A</b>			
STYLE	Th 1.8	matte glossy						
CONCRETA	Th 2.5							
CUTTING	Th 2.5							
CUTTING PLUS	Th 2.5							

## Ht 257.8

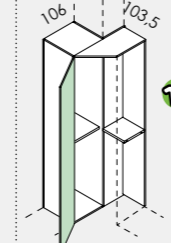
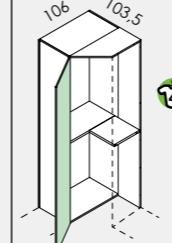
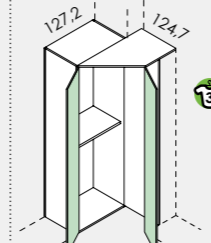
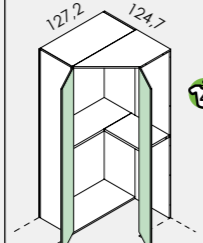

<b>Code</b>	<b>PV18.04T</b>	<b>PV18.05Z</b>		<b>PV18.10X</b>	<b>PV18.11D</b>			
STYLE	Th 1.8	matte glossy						
CONCRETA	Th 2.5							
CUTTING	Th 2.5							
CUTTING PLUS	Th 2.5							

- Components in **CARCASE** colors
- Components in **Types and colors FRONT**
- Clothes hanging bars:** The number indicates the quantity.

# End walk-in wardrobes

The end walk-in wardrobes must always be joined to another module.

## 2 doors W 45

### With universal gap

Gap: 59,5      Made-to-measure gap: 59,5

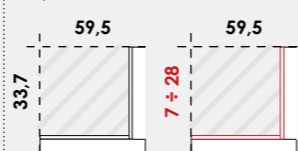

Left examples

**Gap executable to measure, when ordering indicate the desired size.**  
See technical information at the beginning of the chapter.

## 1 door W 60

Specify hinge R or L

### With universal gap

Gap: 57      Made-to-measure gap: 57

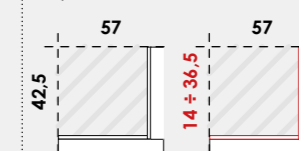

Left examples

**Gap executable to measure, when ordering indicate the desired size.**  
See technical information at the beginning of the chapter.

## Ht 225.8

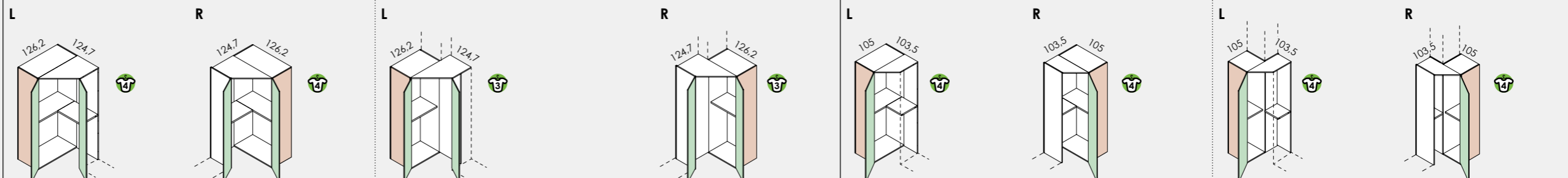

<b>Code</b>	PV18.12L	PV18.13S	PV18.14Y	PV18.21K	PV18.22R	PV18.23X	PV18.24D	PV18.25L
STYLE Th 1.8	matte glossy							
CONCRETA Th 2.5								
CUTTING Th 2.5								
CUTTING PLUS Th 2.5								

## Ht 241.8

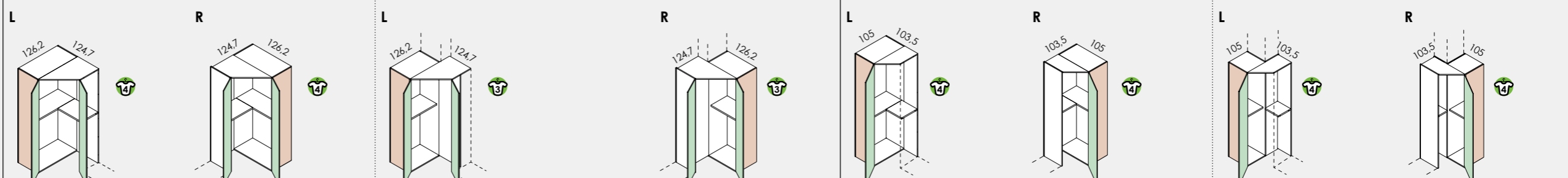

<b>Code</b>	PV18.15E	PV18.16M	PV18.17T	PV18.26S	PV18.27Y	PV18.28E	PV18.29M	PV18.30H
STYLE Th 1.8	matte glossy							
CONCRETA Th 2.5								
CUTTING Th 2.5								
CUTTING PLUS Th 2.5								

## Ht 257.8

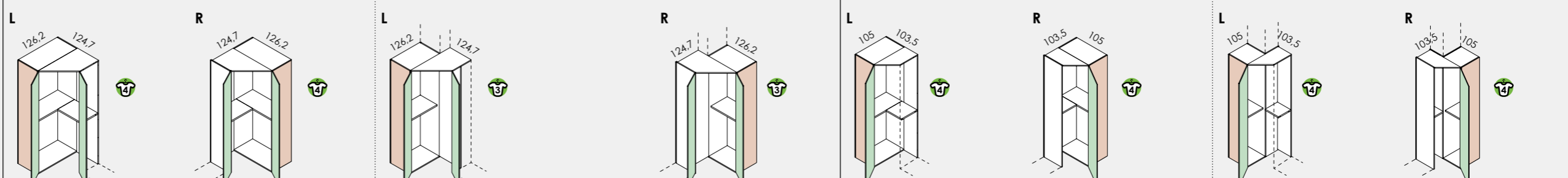

<b>Code</b>	PV18.18Z	PV18.19F	PV18.20C	PV18.31Q	PV18.32W	PV18.33C	PV18.34K	PV18.35R
STYLE Th 1.8	matte glossy							
CONCRETA Th 2.5								
CUTTING Th 2.5								
CUTTING PLUS Th 2.5								

- Components in **CARCASE** colors
- Components in **GROUP 3** colors
- Components in **Types and colors FRONT**
- Clothes hanging bars:** The number indicates the quantity.



# Modular components for wardrobe room

## Ht 225.8 Dpt 59.5

Leading/ending sides also available in Leather gray (LG7H) finish.

### Wardrobes

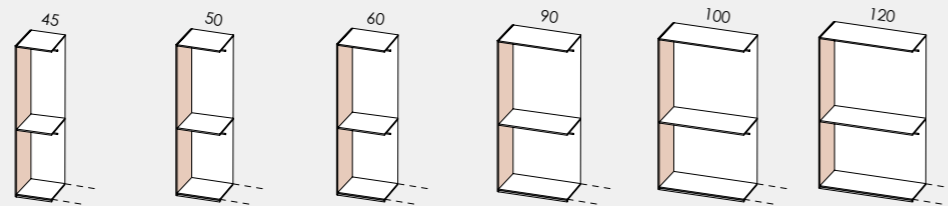

Code	PV19.00W	PV19.01C	PV19.02K	PV19.03R	PV19.04X	PV19.05D			
------	----------	----------	----------	----------	----------	----------	--	--	--

With universal gap

### Corners

They must always be placed side by side with another module.

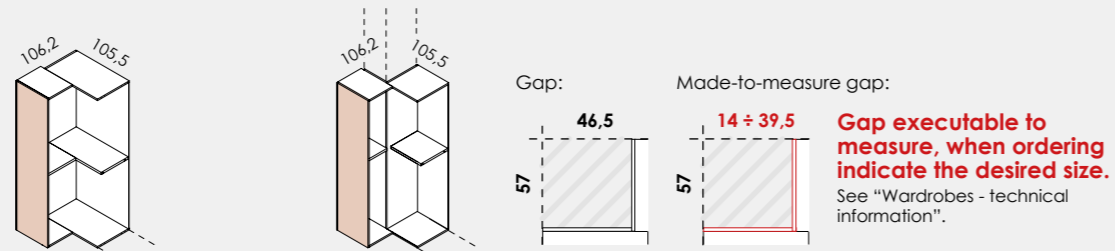

Code	PV19.06L	PV19.07S						
------	----------	----------	--	--	--	--	--	--

### End elements

They must always be placed side by side with another module.

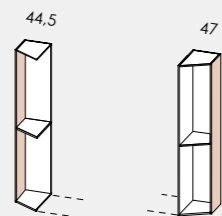

Code	PV19.08Y	PV19.09E						
------	----------	----------	--	--	--	--	--	--

### End side panel

#### Th 2.5



Code	PV10.00G							
------	----------	--	--	--	--	--	--	--

□ Components in **CARCASE** colors  
 ■ Components in **GROUP 3** colors

# Modular components for wardrobe room

## Ht 241.8 Dpt 59.5

Leading/ending sides also available in Leather gray (LG7H) finish.

### Wardrobes

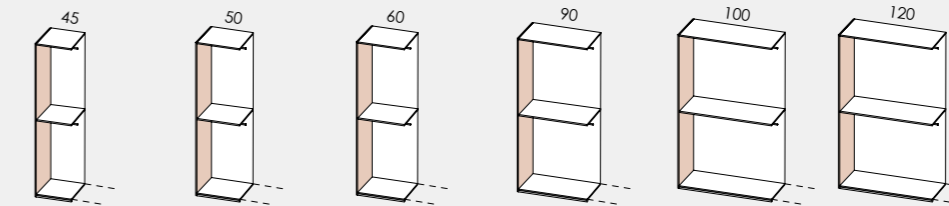

Code	PV19.10B	PV19.11H	PV19.12Q	PV19.13W	PV19.14C	PV19.15K		
------	----------	----------	----------	----------	----------	----------	--	--

With universal gap

### Corners

They must always be placed side by side with another module.

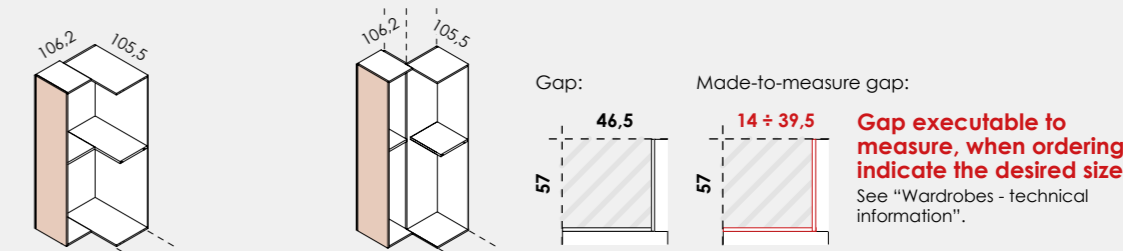

Code	PV19.16R	PV19.17X						
------	----------	----------	--	--	--	--	--	--

### End elements

They must always be placed side by side with another module.

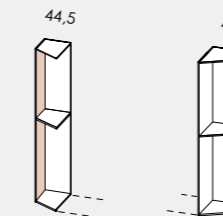

Code	PV19.18D	PV19.19L						
------	----------	----------	--	--	--	--	--	--

### End side panel

#### Th 2.5



Code	PV11.00M							
------	----------	--	--	--	--	--	--	--

# Modular components for wardrobe room

## Ht 257,8 Dpt 59.5

Leading/ending sides also available in Leather gray (LG7H) finish.

### Wardrobes

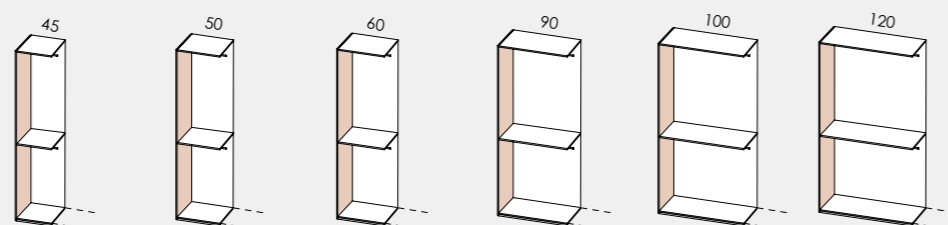

Code	PV19.20G	PV19.21P	PV19.22V	PV19.23B	PV19.24H	PV19.25Q			
------	----------	----------	----------	----------	----------	----------	--	--	--

With universal gap

### Corners

They must always be placed side by side with another module.

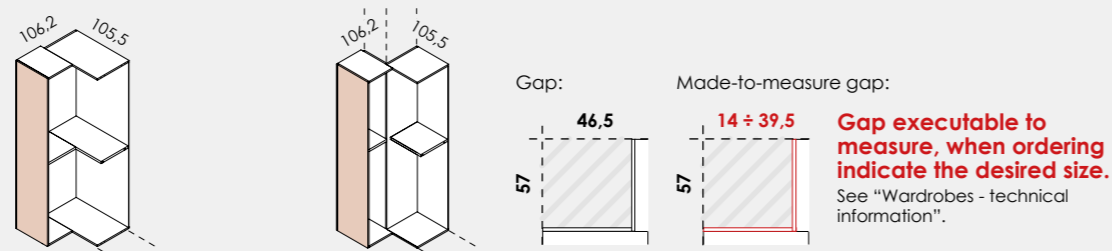

Code	PV19.26W	PV19.27C						
------	----------	----------	--	--	--	--	--	--

### End elements

They must always be placed side by side with another module.

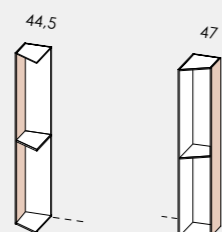

Code	PV19.77E	PV19.76Y						
------	----------	----------	--	--	--	--	--	--

### Side panels

#### Th 2.5

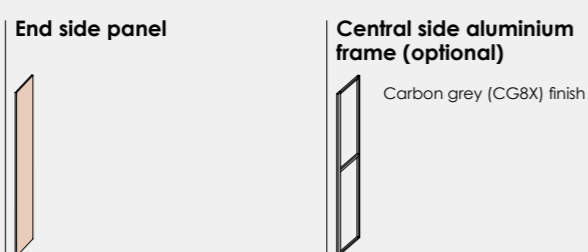

Code	PV12.00R	PV10.42S						
------	----------	----------	--	--	--	--	--	--

□ Components in **CARCASE** colors  
 ■ Components in **GROUP 3** colors

# Modular components for wardrobe room

## Ht 289.8 Dpt 59.5

Leading/ending sides also available in Leather gray (LG7H) finish.

### Wardrobes

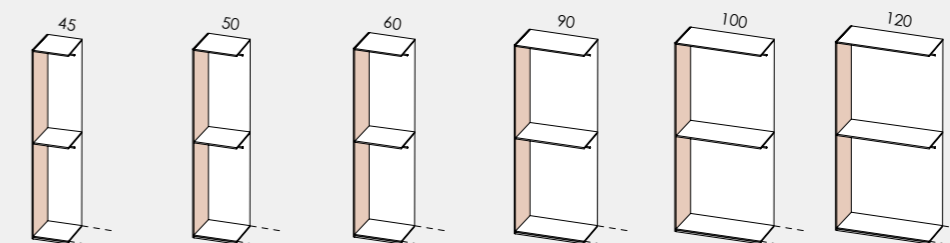

Code	PV19.28K	PV19.29R	PV19.30N	PV19.31U	PV19.32A	PV19.33G			
------	----------	----------	----------	----------	----------	----------	--	--	--

With universal gap

### Corners

They must always be placed side by side with another module.

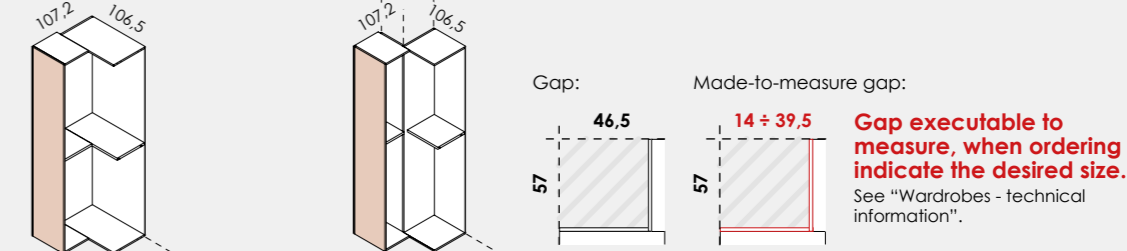

Code	PV10.45M	PV10.46T						
------	----------	----------	--	--	--	--	--	--

### End side panel

#### Th 2.5



Code	PV13.00V							
------	----------	--	--	--	--	--	--	--

# Central walk-in wardrobes for wardrobe room Dpt 59.5

	162.2 x 123.7		105 x 102.5	
	<p>With universal gap</p> <p>Gap: 33.7</p> <p>Made-to-measure gap: 7 + 28</p> <p>Gap executable to measure, when ordering indicate the desired size. See technical information at the beginning of the chapter.</p>		<p>With universal gap</p> <p>Gap: 42.5</p> <p>Made-to-measure gap: 14 + 36.5</p> <p>Gap executable to measure, when ordering indicate the desired size. See technical information at the beginning of the chapter.</p>	
<b>Ht 225.8</b>				
<b>Code</b>	<b>PV19.40T</b>	<b>PV19.41Z</b>	<b>PV19.46G</b>	<b>PV19.47P</b>
<b>Ht 241.8</b>				
<b>Code</b>	<b>PV19.42F</b>	<b>PV19.43N</b>	<b>PV19.48V</b>	<b>PV19.49B</b>
<b>Ht 257.8</b>				
<b>Code</b>	<b>PV19.44U</b>	<b>PV19.45A</b>	<b>PV19.50Y</b>	<b>PV19.51E</b>

Components in **CARCASE** colors

**Clothes hanging bars:** The number indicates the quantity.

# End walk-in wardrobes for wardrobe room Dpt 59.5

The end walk-in wardrobes must always be joined to another module.  
 Leading/ending sides also available in Leather gray (LG7H) finish.

162.2 x 123.7

With universal gap

Gap: 59.5      Made-to-measure gap: 59.5

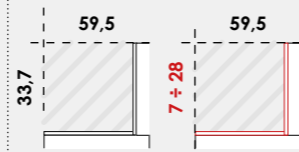

**Gap executable to measure, when ordering indicate the desired size.**  
 See technical information at the beginning of the chapter.

105 x 102.5

Specify hinge  
 R or L

With universal gap

Gap: 57      Made-to-measure gap: 57

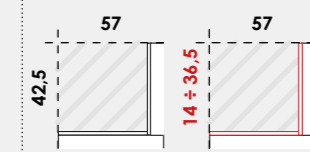

**Gap executable to measure, when ordering indicate the desired size.**  
 See technical information at the beginning of the chapter.

## Ht 225.8

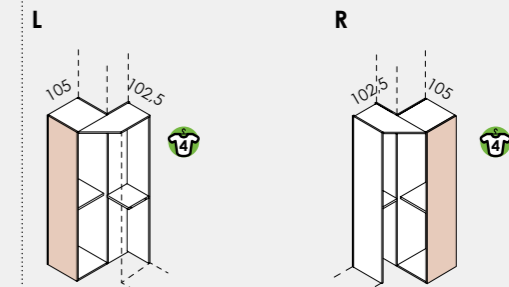
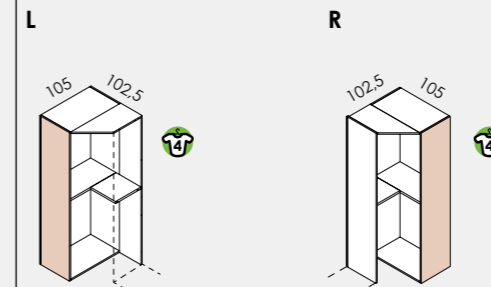
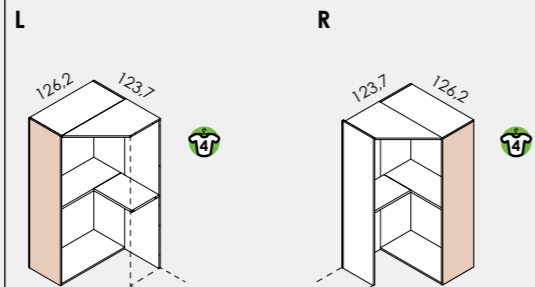

Code	PV19.52M	PV19.53T	PV19.54Z	PV19.61L	PV19.62S	PV19.63Y	PV19.64E	PV19.65M
------	----------	----------	----------	----------	----------	----------	----------	----------

## Ht 241.8

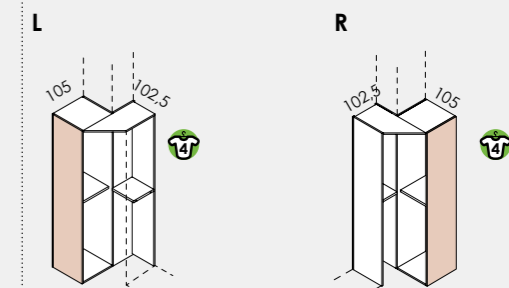
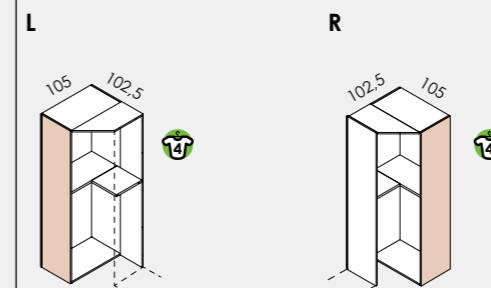
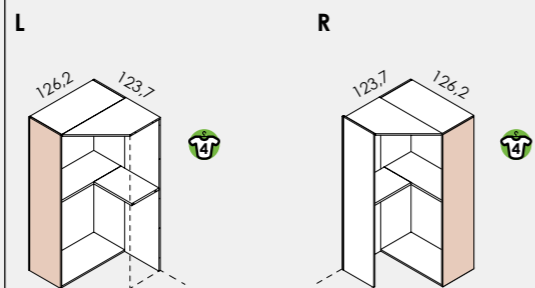

Code	PV19.55F	PV19.56N	PV19.57U	PV19.66T	PV19.67Z	PV19.68F	PV19.69N	PV19.70K
------	----------	----------	----------	----------	----------	----------	----------	----------

## Ht 257.8

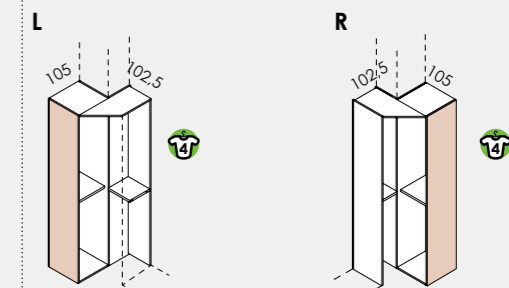
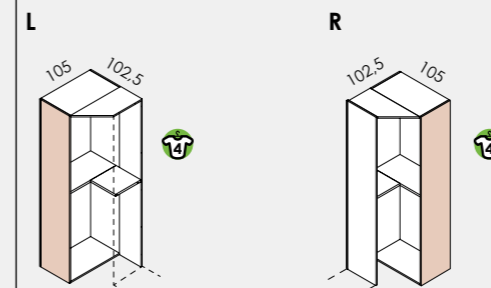
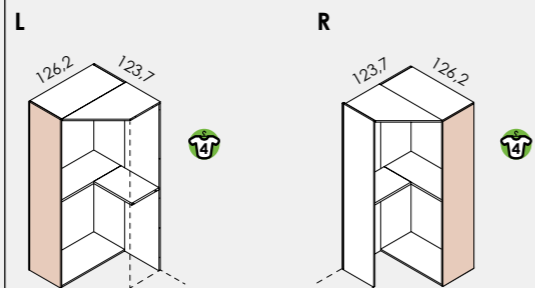

Code	PV19.58A	PV19.59G	PV19.60D	PV19.71R	PV19.72X	PV19.73D	PV19.74L	PV19.75S
------	----------	----------	----------	----------	----------	----------	----------	----------

□ Components in **CARCASE** colors  
 ■ Components in **GROUP 3** colors  
 13 Clothes hanging bars: The number indicates the quantity.

**GROUP 1 colors**

**GROUP 2 colors**

**GROUP 3 colors**

**CARCASE colors**

- Rovere Dorian RD5T
- Ciliegio bianco CB6K
- Noce NC4B
- Bianco opaco B17A
- Rovere white RW3Q
- Malta ML7H
- Desert DS9L
- Grigio Dorian GL4R
- Agave GV7A
- Blu opale BO7H
- Noce naturale NN7H
- Feltro FL8X
- Canapa CN1X
- Basalto BS5T
- Verde Alpi VA5T
- Eucalipto CL1X
- Cemento Masdar CM3Q
- Moka MK6B
- Grigio titanio GZ8T
- Cadaques CQ3Q
- Domy DM7P
- Blu indaco BI4B
- Cipria CP4J
- Rosa bubble RB7Y
- Giallo zafferano GZ8A
- Corallo CR5T
- Bianco UV BU3Q

**Types and colors FRONT**

**ONE**

matte

glossy

**CLUB**

Specify the color of the CLUB handle

Specify the color of the aluminum frame

**WINDOW**

- Rovere white RW3Q
- Feltro FL8X
- Basalto BS5T
- Blu opale BO7H
- Rovere Dorian RD5T
- Cemento Masdar CM3Q
- Grigio titanio GZ8T
- Cipria CP4J
- Ciliegio bianco CB6K
- Bianco opaco B17A
- Domy DM7P
- Rosa bubble RB7Y
- Noce naturale NN7H
- Desert DS9L
- Agave GV7A
- Giallo zafferano GZ8A
- Noce NC4B
- Canapa CN1X
- Verde Alpi VA5T
- Corallo CR5T
- Eucalipto CL1X
- Moka MK6B
- Cadaques CQ3Q
- Malta ML7H
- Grigio Dorian GL4R
- Blu indaco BI4B
- Bianco UV BU3Q
- Bianco opaco B17A
- Desert DS9L
- Canapa CN1X
- Moka MK6B
- Grigio titanio GZ8T
- Basalto BS5T
- Grigio titanio GZ8T
- Verde Alpi VA5T
- Cadaques CQ3Q
- Blu indaco BI4B
- Blu opale BO7H
- Cipria CP4J
- Rosa bubble RB7Y
- Giallo zafferano GZ8A
- Corallo CR5T
- Trasparente TR9M
- Trasparente fumé FT8P
- Stop-sol ST6P
- Specchio SP7L
- Alluminio AL1A
- Titan grey TG7H

**Groups and Double beds**

Groups	574
Mirrors	581
PODIO desks and shelves	582
PODIO bench Dpt 49 - Ht 8	583
Bench Dpt 41 - Ht 10	583
Double bed - technical information	584
Double beds	586
Double beds with rear housing space	592
Double beds with metal bed frame	596
Double beds with SIGMA bed frame	597
Padded double beds	598
UNIQUE padded double bed	600
DARSENA padded double bed	601
Padded double beds ECOCHIC	602
Accessories for double beds	608

All the tallboys and dressers are supplied with anti-tip hardware for fastening to the wall.

All measurements are expressed in centimeters; with tolerance ± 2 cm for upholstered items. The recommended maximum weights of mattresses for beds with lift-up bed base are shown in the table alongside.

Lifting bed base width	Max mattress weight
140 - 150	35 Kg
160 - 180	40 Kg
200	45 Kg

# Groups



## BOLD

- Top, side panels and back panel Th 1.8.
- Drawers Th 1.8 (always without handle).
- **Provided with "Quadro" type metal slides which have push pull and adjustable height.**
- **Drawers internal color CHARM.**
- ALFA-25 adjustable feet.



Optional 4 adjustable feet set:

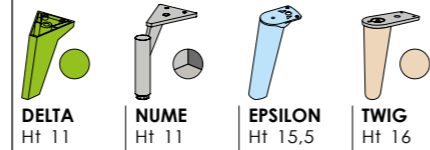

### Chest of drawers

Ht 80,5 With 3 drawers  
Dpt 60,5 Ht 24  
W 123,5

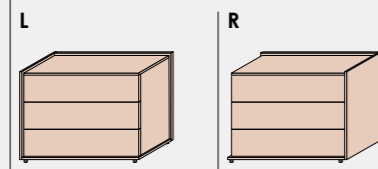

### Tallboy

Ht 120 With 5 drawers  
Dpt 50,5 Ht 24 and 1 Ht 16  
W 63,5

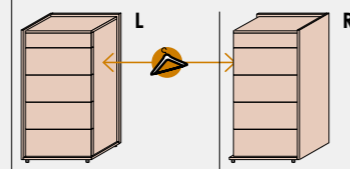

### Bedside tables (with finished back panel)

Ht 40 With 2 drawers  
Dpt 50,5 Ht 16  
W 48,5

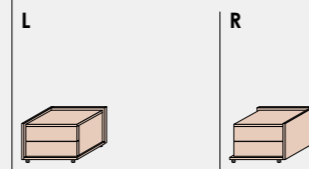

Code	PK51.42N	PK51.43U	PK51.44A	PK51.45G	PK51.46P	PK51.47V
------	----------	----------	----------	----------	----------	----------

## BRICK

- Top, side panels and back panel Th 1.8.
- Drawers Th 1.8.
- **Provided with "Quadro" type metal slides which have adjustable height and soft-close system. Drawers internal color CHARM.**
- In the chest of drawers, in the presence of handles with pitch 256, 320 and 960 mm, there will be only one handle in the central position.
- Ht 0.7 adjustable feet.



Optional 4 adjustable feet set:



### Chest of drawers

Ht 73 With 3 drawers  
Dpt 57 Ht 24  
W 120

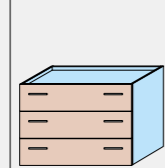

### Tallboy

Ht 121 With 5 drawers  
Dpt 46,5 Ht 24  
W 60

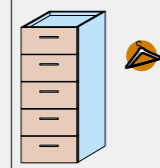

### Bedside tables (with finished back panel)

Ht 33 With 2 drawers  
Dpt 46,5 Ht 16  
W 45

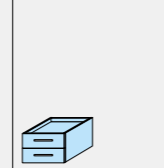

### Bedside table (with 1 drawer)

Ht 33 With 1 drawer  
Dpt 46,5 Ht 32  
W 45

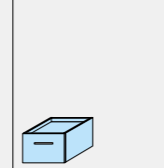

Code	PK54.14X	PK54.15D	PK54.16L	PK54.17S
------	----------	----------	----------	----------

- Components in **GROUP 2 colors**
- Components in **GROUP 3 colors**
- \* Back panel in CHARM finish

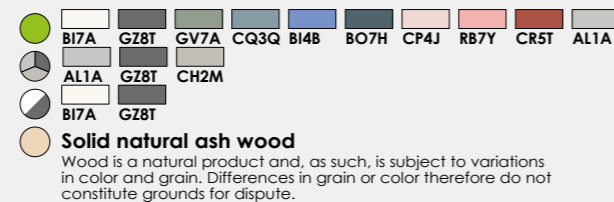

## CHIC

- Top and side panels Th 1.8.
- Drawers Th 1.8 (always without handle).
- **Provided with "Quadro" type metal slides which have adjustable height and soft-close system. Drawers internal color CHARM.**
- Ht 0.7 adjustable feet.



Vertical profiles colours:



### Chest of drawers

Ht 74,7 With 3 drawers  
Dpt 54,5 Ht 24  
W 129,6

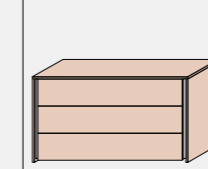

### Tallboy

Ht 122,7 With 5 drawers  
Dpt 45 Ht 24  
W 69,6

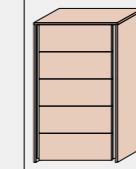

### Bedside table

Ht 34,5 With 2 drawers  
Dpt 45 Ht 16  
W 54,6

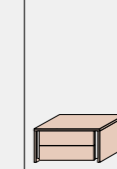

### Bedside table

Ht 50,5 With 3 drawers  
Dpt 45 Ht 16  
W 54,6

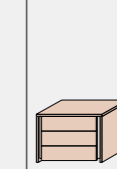

Code	PK51.48B	PK51.49H	PK51.50E	PK51.51M
------	----------	----------	----------	----------

## GAPE

- Top, base and side panels Th 1.8.
- Drawers Th 1.8 (always without handle).
- **Provided with "Quadro" type metal slides which have push pull and adjustable height.**
- **Drawers internal color CHARM.**
- Open compartment always positioned on the left.
- Ht 0.7 adjustable feet.



In the chest of drawers, by choosing a foot kit, an additional foot will be supplied (with surcharge) to position under the vertical partition.  
Extra feet: \_\_\_\_\_

Optional 4 adjustable feet set:

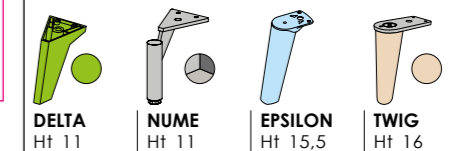

### Chest of drawers

Ht 76,5 With 3 drawers  
Dpt 57,5 Ht 24  
W 124

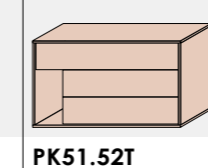

### Bedside table

Ht 40,5 With 1 drawer  
Dpt 47,5 Ht 24 and 1 Ht 12  
W 62

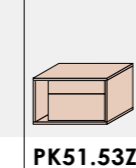

Code	PK51.52T	PK51.53Z
Without insert		
With insert		

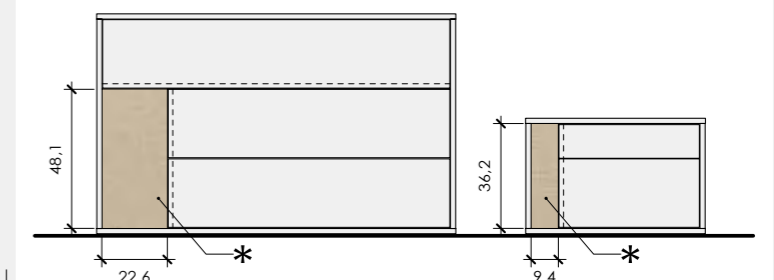

Painted metal insert (optional) for open compartment

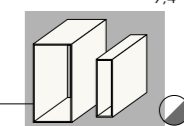

**BERNARDO**  
Clothes hangers

Code **P07.70T**

Ht 96  
Dpt 2  
W 28



# Groups

## LABEL

- Top and side panels Th 1.8.
- Th 1.8 drawers.
- Provided with "Quadro" type metal slides which have adjustable height and soft-close system. Drawers internal color CHARM.
- Metal handle in finish: Bianco opaco (BI7A), Alluminio (AL1A) and Carbon Grey (CG8X).
- Plinth Th 25 mm with non-slip feet H 7 mm.



**Chest of drawers**  
Ht 74,8 With 3 drawers  
Dpt 45,2 Ht 23,6  
W 126,6

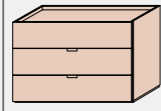

Code **PK54.00R**

**Tallboy**  
Ht 122,8 With 5 drawers  
Dpt 45,2 Ht 23,6  
W 54,6

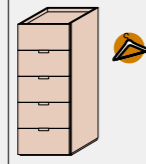

Code **PK54.01X**

**Bedside table**  
Ht 50,9 With 2 drawers  
Dpt 45,2 Ht 23,6  
W 54,6



Code **PK54.02D**

## LEADER

- Top and side panels Th 2.5.
- Th 1.8/2.5 drawers (always without handle).
- Provided with "Quadro" type metal slides which have adjustable height and soft-close system. Drawers internal color CHARM.
- Ht 2.5 concealed adjustable feet.
- The position of the drawers can be decided during installation; the finish of the insert is customizable.

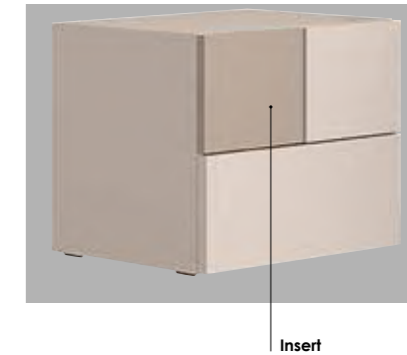

**Chest of drawers**  
Ht 79,2 With 3 drawers  
Dpt 55,6 Ht 25,2  
W 128,1

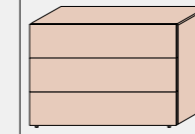

Code **PK54.09Z**

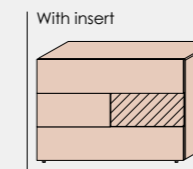

Code **PK54.10W**

**Bedside table**  
Ht 47,2 With 2 drawers  
Dpt 45,6 Ht 22  
W 51,1

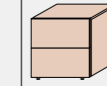

Code **PK54.11C**

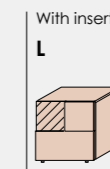

Code **PK54.12K**

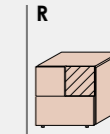

Code **PK54.13R**

## LAGUNA

- Top and sides Th 1.8.
- Drawers Th 1.8 (always without handle).
- Supplied with "Quadro" type height-adjustable push pull metal runners.
- Drawer interior in CHARM finish.
- Plinth Th 25 mm with adjustable feet Ht 7 mm.



**Chest of drawers**  
Dpt 56,8  
W 123,6

Ht 79,3  
With 3 drawers  
Ht 23,6

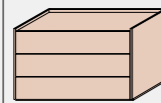

Code **PK54.03L**

Ht 28,1  
With 1 drawer  
Ht 23,6

Stackable

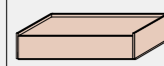

Code **PK54.04S**

**Add-on unit**  
Dpt 56,8  
W 52,3

Ht 28,1  
With 1 drawer  
Ht 23,6

Stackable  
Place on the L or R side of the dresser

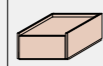

Code **PK54.05Y**

**Tallboy**  
Dpt 45,8  
W 52,3

Ht 130,5  
With 5 drawers  
Ht 23,6

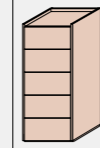

Code **PK54.06E**

**Bedside table**  
Dpt 45,8  
W 52,3

Ht 28,1  
With 1 drawer  
Ht 23,6

Stackable



Code **PK54.07M**

Ht 53,7  
With 2 drawers  
Ht 23,6



Code **PK54.08T**

## LOOK

- Top and side panels Th 1.8.
- Th 1.8 drawers (always without handle).
- Provided with "Quadro" type metal slides which have adjustable height and soft-close system. Drawers internal color CHARM.
- Ht 0.7 adjustable feet.



Internal profile colours:



Optional 4 adjustable feet set:

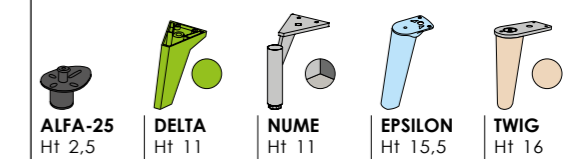

**Chest of drawers**  
Dpt 84  
W 120

Ht 84  
With 3 drawers  
Ht 24 and 1 Ht 12

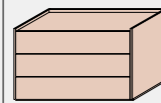

Code **PK51.54F**

**Tallboy**  
Ht 120,5 With 5 drawers  
Dpt 48,5 Ht 24  
W 60

Ht 120,5  
With 5 drawers  
Ht 24

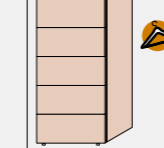

Code **PK51.55N**

**Bedside table**  
Ht 32  
Dpt 48,5  
W 45

Ht 32  
With 2 drawers  
Ht 16

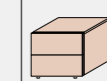

Code **PK51.56U**

Components in GROUP 2 colors  
Components in GROUP 3 colors

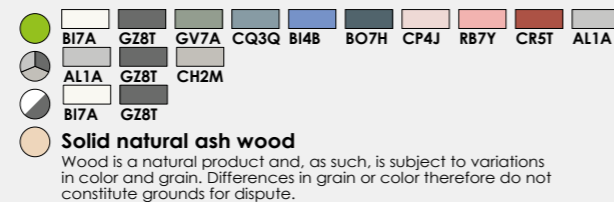

Wood is a natural product and, as such, is subject to variations in color and grain. Differences in grain or color therefore do not constitute grounds for dispute.

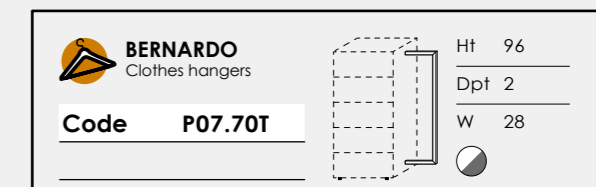

# Groups



## QUADRO

- Top, base and side panels Th 1.8.
- Drawers Th 1.8
- Provided with "Quadro" type metal slides which have adjustable height and soft-close system. Drawers internal color CHARM.
- Ht 0.7 adjustable feet.



**Handles available:** \*it can be positioned on the R or L

<b>PIN</b> G76W	<b>BUL</b> G77Z (32) G78C (160)	<b>FRAME *</b> G60M (32) G55R (192)	<b>BIS</b> G35F (160)	<b>NIK</b> G64Y (160) G65L (256) G66K (320)	<b>PUL</b> G53Z (160) G45H (256)	<b>SET</b> G52R (160) G25D (320)	<b>VIM</b> G71B (160) G72P (256)	<b>EASY</b> G56F (320)	<b>PUSH PULL</b>

**Optional 4 adjustable feet set:**

<b>DELTA</b> Ht 11	<b>NUME</b> Ht 11	<b>EPSILON</b> Ht 15,5	<b>TWIG</b> Ht 16
-----------------------	----------------------	---------------------------	----------------------

	Chest of drawers	Chest of drawers	Tallboy	Bedside table	
	Ht 76,5 Dpt 57,5 W 101 With 3 drawers Ht 24	Ht 100,5 Dpt 47,5 W 101 With 4 drawers Ht 24	Ht 124,5 Dpt 47,5 W 52,5 With 5 drawers Ht 24	Ht 40,5 Dpt 47,5 W 52,5 With 1 drawer Ht 24 and 1 Ht 12	Ht 40,5 Dpt 47,5 W 52,5 With 1 drawer Ht 12
<b>Code</b>	<b>PK51.57A</b>	<b>PK51.58G</b>	<b>PK51.59P</b>	<b>PK51.60L</b>	<b>PK51.61S</b>
<b>ONE</b>	matte glossy				

## STICK

- Top and side panels Th 2.5.
- Drawers Th 1.8.
- Provided with "Quadro" type metal slides which have adjustable height and soft-close system. Drawers internal color CHARM.
- Ht 0.7 adjustable feet.



**Handles available:**

<b>PIN</b> G76W	<b>BUL</b> G77Z (32) G78C (160)	<b>BIS</b> G35F (160)	<b>NIK</b> G64Y (160) G65L (256) G66K (320)	<b>PUL</b> G53Z (160) G45H (256)	<b>SET</b> G52R (160) G25D (320)	<b>VIM</b> G71B (160) G72P (256)	<b>EASY</b> G56F (320)	<b>PUSH PULL</b>
--------------------	---------------------------------------	--------------------------	--	--	--	--	---------------------------	------------------

	Chest of drawers	Tallboy	Bedside table				Glass shelf
	Ht 89,7 Dpt 57,1 W 102,5 With 3 drawers Ht 24 and 1 Ht 12	Ht 137,7 Dpt 45,8 W 53,7 With 5 drawers Ht 24 and 1 Ht 12	Ht 41,7 Dpt 45,8 W 53,7 With glass movable shelf	With fixed intermediate shelf	with small drawer Ht 12	With 1 drawer Ht 24 and 1 Ht 12	Ht 41,7 For bedside table <b>PK51.64M</b> Dpt 41,8 W 48
<b>Code</b>	<b>PK51.62Y</b>	<b>PK51.63E</b>	<b>PK51.64M</b>	<b>PK51.65T</b>	<b>PK51.66Z</b>	<b>PK51.67F</b>	<b>P93.90H</b>
<b>ONE</b>	matte glossy						

■ Components in **GROUP 2 colors**  
■ Components in **GROUP 3 colors**  
■ Components in **Types and colors FRONT**  
 \* Back panel in CHARM finish

■ B17A	■ CN1X	■ GL4R	■ GZ8T	■ DM7P	■ GV7A	■ BO7H	■ CP4J	■ GZ8A
■ B17A	■ GZ8T	■ GV7A	■ CQ3Q	■ B14B	■ BO7H	■ CP4J	■ R87Y	■ CR5T
■ AL1A	■ GZ8T	■ CH2M						
■ B17A	■ GZ8T							

■ Solid natural ash wood  
 Wood is a natural product and, as such, is subject to variations in color and grain. Differences in grain or color therefore do not constitute grounds for dispute.

## TETRIS

- Top, base and side panels Th 1.8.
- Drawers Th 1.8 (always without handle) with lacquered panel in MDF Th 4 mm always positioned on the left.
- Provided with "Quadro" type metal slides which have push pull and adjustable height. Drawers internal color CHARM.
- Ht 0.7 adjustable feet.



**Optional 4 adjustable feet set:**

<b>DELTA</b> Ht 11	<b>NUME</b> Ht 11	<b>EPSILON</b> Ht 15,5	<b>TWIG</b> Ht 16
-----------------------	----------------------	---------------------------	----------------------

	Chest of drawers	Chest of drawers	Tallboy	Bedside table	
	Ht 76,5 Dpt 57,5 W 101 With 3 drawers Ht 24	Ht 100,5 Dpt 47,5 W 101 With 4 drawers Ht 24	Ht 124,5 Dpt 47,5 W 52,5 With 5 drawers Ht 24	Ht 40,5 Dpt 47,5 W 52,5 With 1 drawer Ht 24 and 1 Ht 12	Ht 40,5 Dpt 47,5 W 52,5 With 1 drawer Ht 12
<b>Code</b>	<b>PK51.68N</b>	<b>PK51.69U</b>	<b>PK51.70R</b>	<b>PK51.71X</b>	<b>PK51.72D</b>
<b>ONE</b>	matte glossy				

## TOWER

- Top and side panels Th 1.8.
- Drawers Th 1.8 (always without handle).
- Provided with "Quadro" type metal slides which have adjustable height and soft-close system. Drawers internal color CHARM.
- Ht 0.7 adjustable feet.



**Internal profile colours:**

■ B17A	■ AL1A	■ GZ8T
--------	--------	--------

**Optional 4 adjustable feet set:**

<b>DELTA</b> Ht 11	<b>NUME</b> Ht 11	<b>EPSILON</b> Ht 15,5	<b>TWIG</b> Ht 16
-----------------------	----------------------	---------------------------	----------------------

	Chest of drawers	Chest of drawers	Tallboy	Bedside table
	Ht 73,5 Dpt 55 W 120 With 3 drawers Ht 24	Ht 97,5 Dpt 48,5 W 97,5 With 4 drawers Ht 24	Ht 121,5 Dpt 48,5 W 60 With 5 drawers Ht 24	Ht 33,5 Dpt 48,5 W 45 With 2 drawers Ht 16
<b>Code</b>	<b>PK51.73L</b>	<b>PK51.74S</b>	<b>PK51.75Y</b>	<b>PK51.76E</b>
<b>ONE</b>				

**BERNARDO**  
 Clothes hangers

<b>Code</b>	<b>P07.70T</b>	Ht 96
		Dpt 2
		W 28

# Groups

## TULIP

- Top and side panels Th 1.8.
- Drawers Th 1.8.
- Provided with "Quadro" type metal slides which have adjustable height and soft-close system. Drawers internal color CHARM.
- Protruding element can be positioned on the left or on the right.
- ALFA-25 adjustable feet.



### Handles available:

\* 2 on chest of drawers

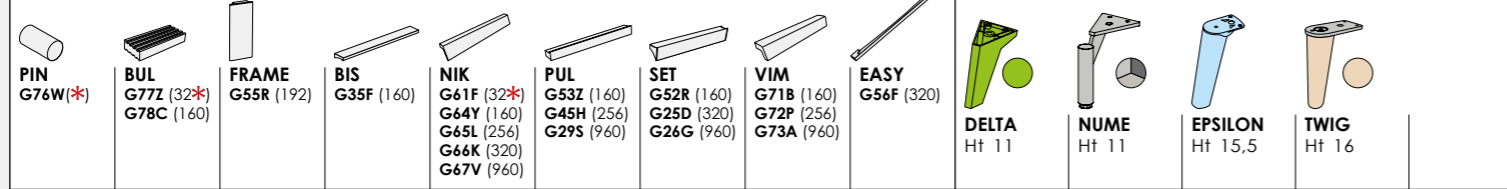

### Optional 4 adjustable feet set:

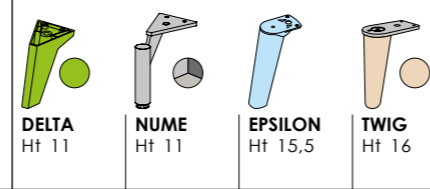

#### Chest of drawers

Ht 86 With 3 drawers  
Dpt 59,2 Ht 27.8  
W 140

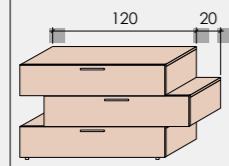

#### Chest of drawers

Ht 58 With 2 drawers  
Dpt 59,2 Ht 27.8  
W 140

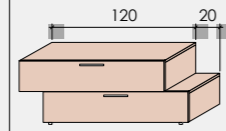

#### Bedside table

Ht 30,5 With 1 drawer  
Dpt 46,5 Ht 27.8  
W 45



Code	PK52.34Z	PK52.35F	PK52.36N
------	----------	----------	----------

- Components in **CARCASE** colors
- Components in **GROUP 2** colors
- Components in **GROUP 3** colors

- B17A GZ8T GV7A CQ3Q B14B BO7H CP4J R87Y CR5T AL1A
  - AL1A GZ8T CH2M
  - Solid natural ash wood
- Wood is a natural product and, as such, is subject to variations in color and grain. Differences in grain or color therefore do not constitute grounds for dispute.

# Mirrors

## Frame Th 2.5

	Ht 80 W 80	Ht 112 W 60	Ht 190 W 80
Code	P92.58F	P92.59M	P92.60S

## With coloured uprights Dpt 1.8

	Ht 90 W 60	Ht 180 W 60
Code	PK50.95E	PK50.96M

## Faux leather frame Th 2.5

	Ht 80 W 80	Ht 185 W 80
Code	PL50.30S	PL50.31Y

## Mirrors with biadhesive tape

P30.44L can be mounted on the insides of doors.

	∅ 50	∅ 80	Ht 80 W 80	Ht 147 W 32	Ht 125 W 60
Code	H35.31A	P92.56V	P92.57A	P30.44L	P30.45R

- FAUX LEATHER TAPE 0111 0102 0603 0415 0503 0605 0700 0608 0901
- Mirror.

# PODIO desks and shelves

- We recommend positioning the desk top at a maximum height of 77 cm from the floor.
- Adjustable support brackets for wall fixing are included.
- Maximum load recommended: 60 Kg.
- Element can not be modified.

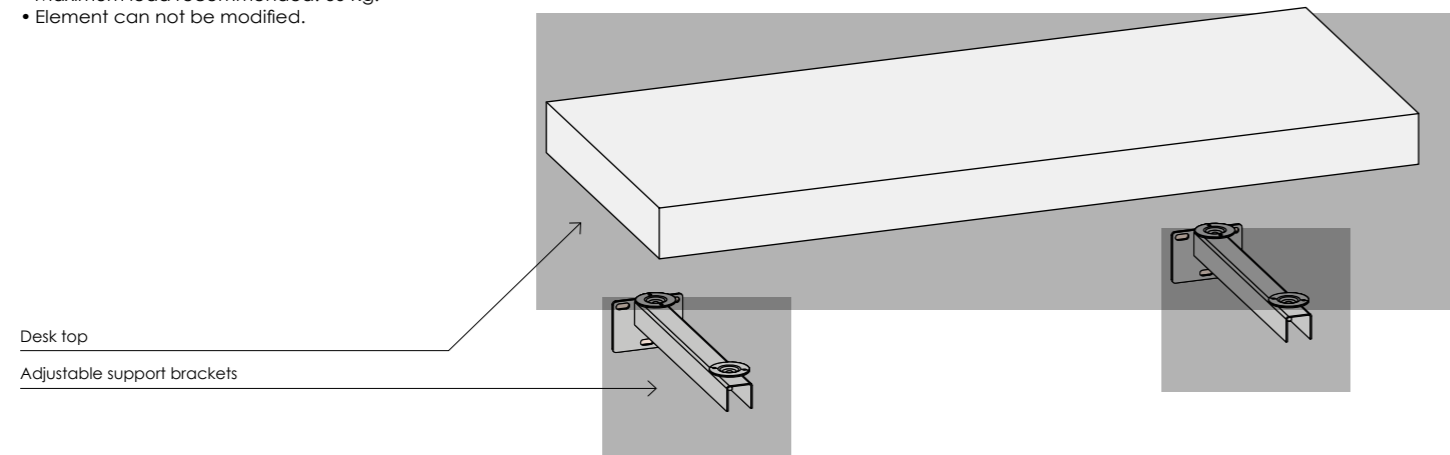

On request, the top can be fitted with the following built-in technology:



The holes required will be drilled in fixed positions.  
For details, see the chapter "Holes for built-in technology".

## PODIO desks

Ht 8  
Dpt 49

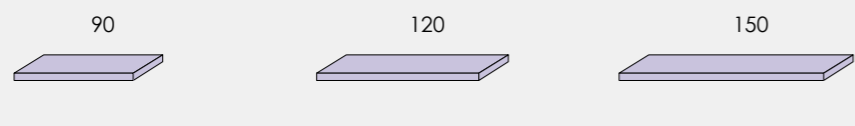

Code	PL48.95P	PL48.96V	PL48.97B	
------	----------	----------	----------	--

## Back panel

Wall fixing with the provided hardware.

Ht 27,5  
Th 1,8

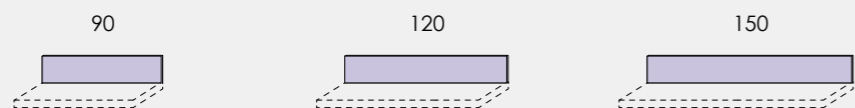

Code	PL48.81G	PL48.82P	PL48.83V	
------	----------	----------	----------	--

## Shelves \*

With shelf holders INTEGRATED

Ht 5,5  
Dpt 24



Code	PL38.75Z <sup>2</sup>	PL38.76F <sup>3</sup>	PL38.77N <sup>3</sup>	
------	-----------------------	-----------------------	-----------------------	--

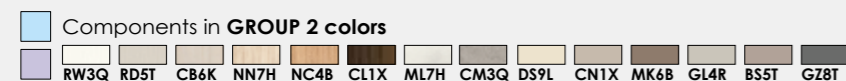

<sup>2</sup> Indicates the number of shelf holders supplied.

\* **Maximum recommended load (net of shelves): 30 kg** for each pair of shelf holders.  
N.B. for loads evenly distributed over the shelf.

# PODIO bench Dpt 49 - Ht 8

- With adjustable feet.
- Element can not be modified.
- Finishes are on 3 sides (needs positioning against the wall).

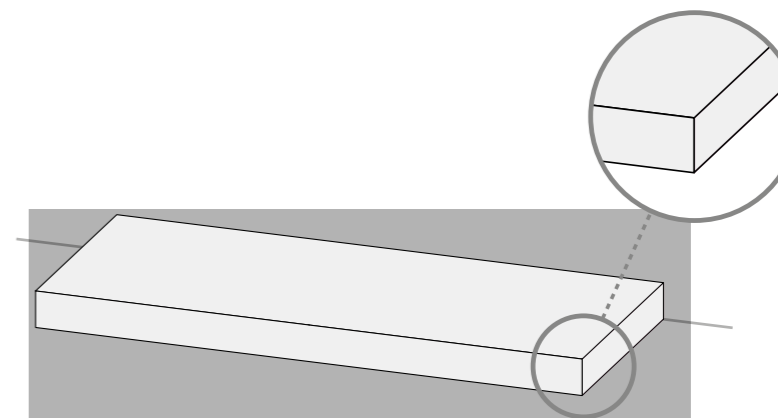

Code	PL48.84B	PL48.85H	PL48.86Q	
------	----------	----------	----------	--

## Back panels

Wall fixing with the provided hardware.

Ht 27,5  
Th 1,8

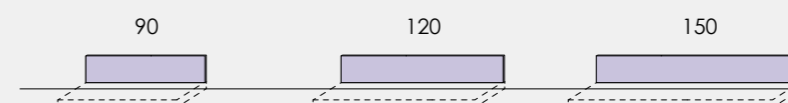

Code	PL48.81G	PL48.82P	PL48.83V	
------	----------	----------	----------	--

# Bench Dpt 41 - Ht 10

- Top and structure made with Th 1.8 panels.
- With adjustable feet.
- Element can not be modified.
- Finishes are on all of the four sides (it can be placed in any position).
- You can use Modular self standing elements D 45 or 32.5.

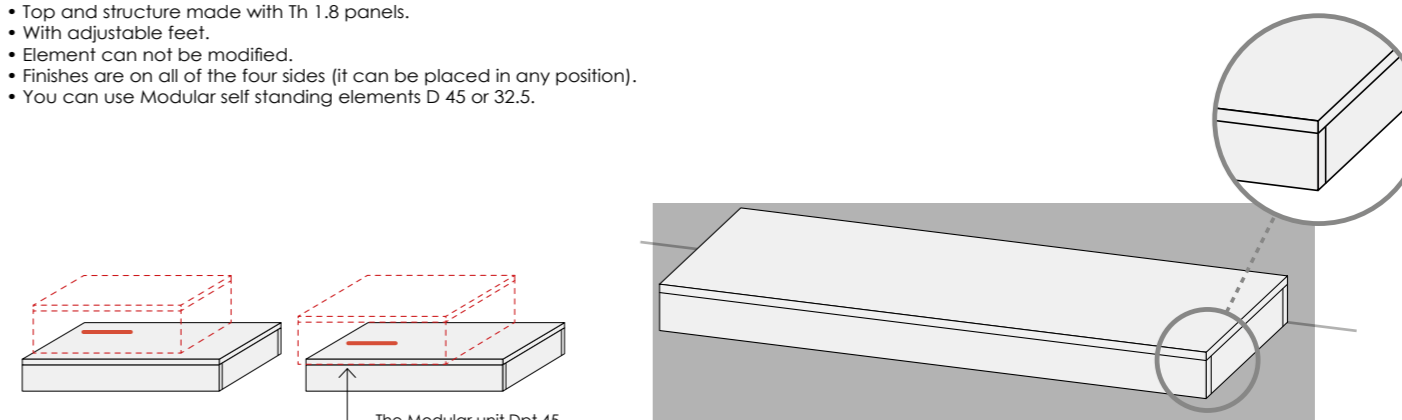

Code	P78.97H	P78.98P	P78.99U	P78.49X
------	---------	---------	---------	---------

# Double bed - technical information

**ATLANTE**  
bed frame

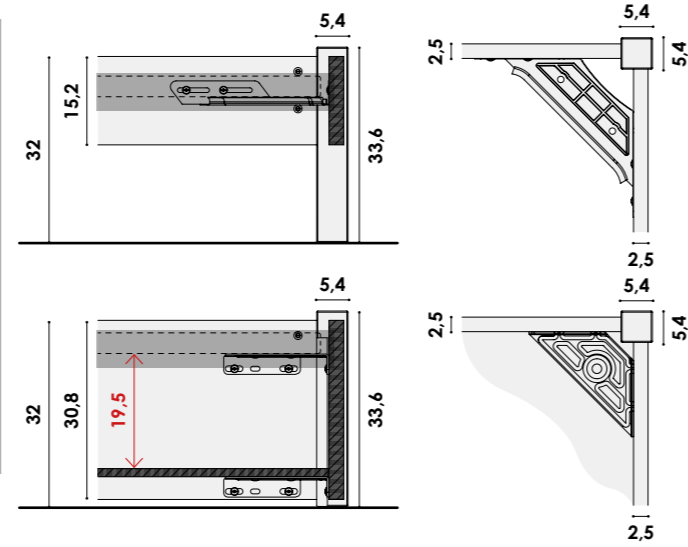
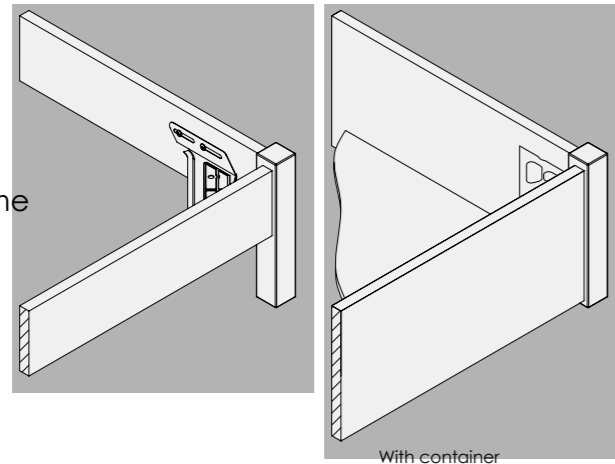

**SIGMA**  
bed frame

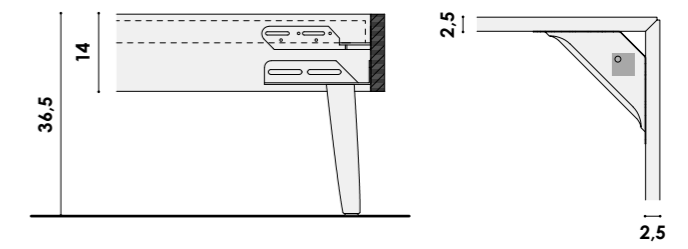
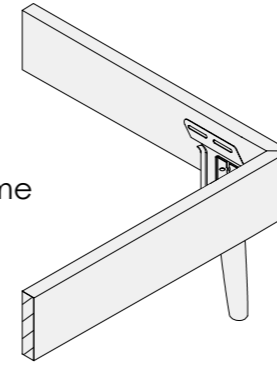

**GIOVE**  
bed frame

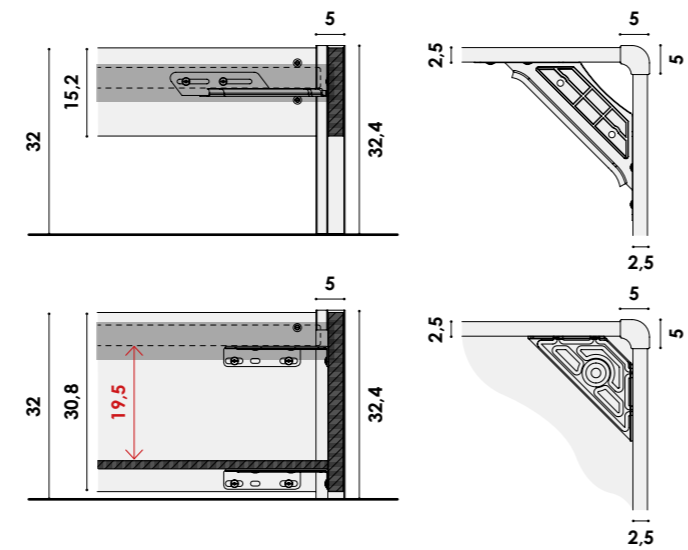
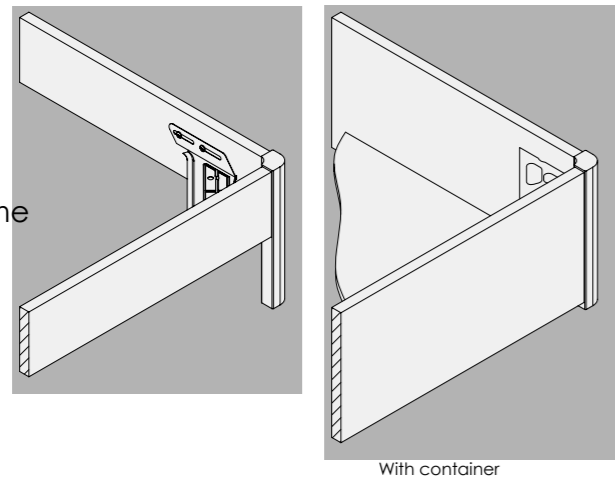

**MARTE**  
bed frame

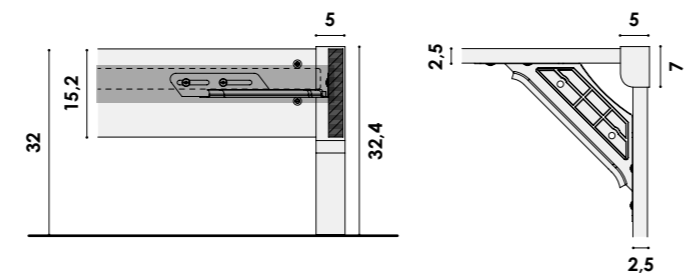
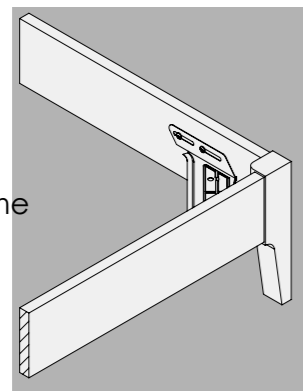

**NETTUNO**  
bed frame

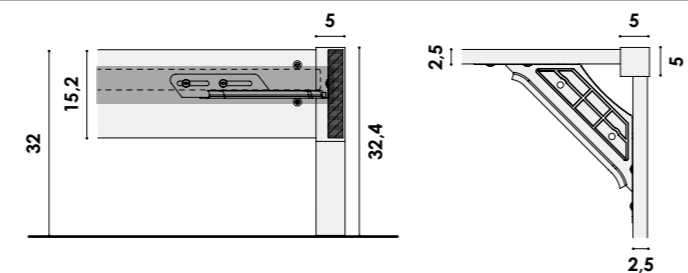
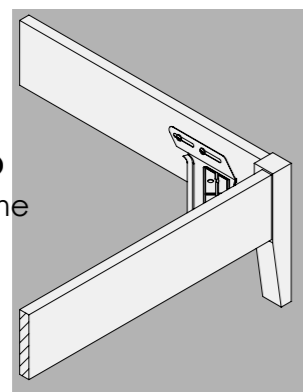



# Double beds



## Headboards

 <b>ATLANTE bed frame</b> Without bed base. Only the bed base without feet can be installed.	 <b>ATLANTE bed frame</b> With slatted, lifting bed base. Space inside container: W 163 Ht 19,5 Dpt 197/207	 <b>GIOVE bed frame</b> Without bed base. Only the bed base without feet can be installed.	 <b>GIOVE bed frame</b> With slatted, lifting bed base. Space inside container: W 163 Ht 19,5 Dpt 197/207	 <b>MARTE bed frame</b> Without bed base. Only the bed base without feet can be installed.	 <b>NETUNO bed frame</b> Without bed base. Only the bed base without feet can be installed.	<b>With footboard</b> Without bed base. Only the bed base without feet can be installed (unless otherwise indicated).
---	---	---	---	---	--	---

<b>COSY</b>  Ht 100 Dpt 207,5 217,5 W 178,5	 Ht 100 Dpt 210,5 220,5 W 178,5	 Ht 100 Dpt 207 217 W 178,5	 Ht 100 Dpt 210,5 220,5 W 178,5	 Ht 100 Dpt 207 217 W 178,5	 Ht 100 Dpt 207 217 W 178,5
--	---	---	---	---	---

bed base W	Code	internal dimensions	Code	internal dimensions	Code	internal dimensions	Code	internal dimensions	Code	internal dimensions	Code	internal dimensions
160 x 190 200	PK51.77M	192,5 x 161,5	PK51.78T	190 x 160	PK51.79Z	192,5 x 161,5	PK51.80W	190 x 160	PK51.81C	192,5 x 161,5	PK51.82K	192,5 x 161,5
180 x 200	-	-	-	-	-	-	-	-	-	-	-	-

<b>DIVA</b>  Ht 90 Dpt 200 210 W 172 192	 Ht 90 Dpt 203 213 W 172 192	 Ht 90 Dpt 199,5 209,5 W 172 192	 Ht 90 Dpt 202,7 212,7 W 172 192	 Ht 90 Dpt 199,5 209,5 W 172 192	 Ht 90 Dpt 199,5 209,5 W 172 192
--	---	---	---	---	---

bed base W	Code	internal dimensions	Code	internal dimensions	Code	internal dimensions	Code	internal dimensions	Code	internal dimensions	Code	internal dimensions
160 x 190 200	PL43.08N	192,5 x 161,5	PL43.18T	190 x 160	PL43.46W	192,5 x 161,5	PL43.47C	190 x 160	PL56.62X	192,5 x 161,5	PL56.63D	192,5 x 161,5
180 x 200	PL59.48P	202,5 x 181,5	PL59.49V	200 x 180	PL59.50S	202,5 x 181,5	PL59.51Y	200 x 180	PL59.52E	202,5 x 181,5	PL59.53M	202,5 x 181,5

<b>ELFO</b>  Ht 75 Dpt 200 210 W 170 190	 Ht 75 Dpt 203 213 W 170 190	 Ht 75 Dpt 199,5 209,5 W 170 190	 Ht 75 Dpt 202,7 212,7 W 170 190	 Ht 75 Dpt 199,5 209,5 W 170 190	 Ht 75 Dpt 199,5 209,5 W 170 190	 Ht 75 Dpt 197 207 W 170 190
--	---	---	---	---	---	---

bed base W	Code	internal dimensions	Code	internal dimensions	Code	internal dimensions	Code	internal dimensions	Code	internal dimensions	Code	internal dimensions
160 x 190 200	PL43.69B	192,5 x 161,5	PL43.70Y	190 x 160	PL43.71E	192,5 x 161,5	PL43.72M	190 x 160	PL56.74R	192,5 x 161,5	PL56.75X	192,5 x 161,5
180 x 200	PL59.66M	202,5 x 181,5	PL59.67T	200 x 180	PL59.68Z	202,5 x 181,5	PL59.69F	200 x 180	PL59.70C	202,5 x 181,5	PL59.71K	202,5 x 181,5
											P35.30AP	191 x 161,5
												201 x 161,5
												201 x 181,5

<b>LEO</b>  Ht 100 Dpt 200 210 W 179,5	 Ht 100 Dpt 203 213 W 179,5	 Ht 100 Dpt 199,5 209,5 W 179,5	 Ht 100 Dpt 202,7 212,7 W 179,5	 Ht 100 Dpt 199,5 209,5 W 179,5	 Ht 100 Dpt 199,5 209,5 W 179,5
---	---	---	---	---	---

bed base W	Code	internal dimensions	Code	internal dimensions	Code	internal dimensions	Code	internal dimensions	Code	internal dimensions	Code	internal dimensions
160 x 190 200	PL43.26L	192,5 x 161,5	PL43.27S	190 x 160	PL43.28Y	192,5 x 161,5	PL43.29E	190 x 160	PL56.56T	192,5 x 161,5	PL56.57Z	192,5 x 161,5
180 x 200	-	-	-	-	-	-	-	-	-	-	-	-

Components in **CARCASE** colors  
 Components in **GROUP 2** colors  
 Components in **GROUP 3** colors  
 The headboard is available in two colours.

Padded components with removable covers.

FABRIC JENNY	0402	0403	0503	0900	0903	0905	0314	0303	0805	0706	0704	0601	0604
FABRIC KENYA	0014	0013	0016	0020	0019								
FALUX LEATHER TAPE	0111	0102	0603	0415	0503	0605	0700	0608	0901				

Mattresses, pillows and slatted bed base  
See back cover wing

When ordering, specify for bed base D 191 or 200.



# Double beds



## Headboards

 <b>ATLANTE bed frame</b> Without bed base. Only the bed base without feet can be installed.	 <b>ATLANTE bed frame</b> With slatted, lifting bed base. Space inside container: W 163 Ht 19,5 Dpt 197/207	 <b>GIOVE bed frame</b> Without bed base. Only the bed base without feet can be installed.	 <b>GIOVE bed frame</b> With slatted, lifting bed base. Space inside container: W 163 Ht 19,5 Dpt 197/207	 <b>MARTE bed frame</b> Without bed base. Only the bed base without feet can be installed.	 <b>NETUNO bed frame</b> Without bed base. Only the bed base without feet can be installed.	<b>With footboard</b> Without bed base. Only the bed base without feet can be installed (unless otherwise indicated).
--	--	--	--	--	---	---

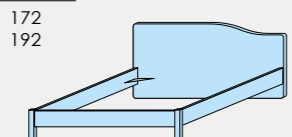
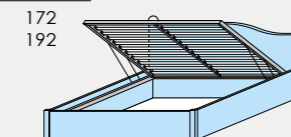
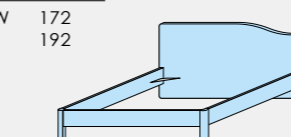
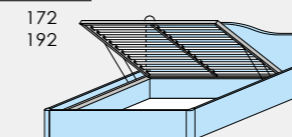
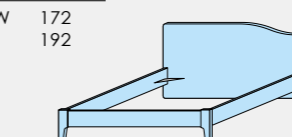
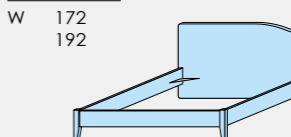
 <b>MUSA</b>	Ht 90 Dpt 200 210 W 172 192	Ht 90 Dpt 203 213 W 172 192	Ht 90 Dpt 199,5 209,5 W 172 192	Ht 90 Dpt 202,7 212,7 W 172 192	Ht 90 Dpt 199,5 209,5 W 172 192	Ht 90 Dpt 199,5 209,5 W 172 192
						

bed base W	Code	internal dimensions	Code	internal dimensions	Code	internal dimensions	Code	internal dimensions	Code	internal dimensions	Code	internal dimensions
160 x 190 200	PL43.05T	192,5 x 161,5	PL43.17M	190 x 160	PL43.52A	192,5 x 161,5	PL43.53G	190 x 160	PL56.64L	192,5 x 161,5	PL56.65S	192,5 x 161,5
180 x 200	PL59.54T	202,5 x 161,5	PL59.55Z	200 x 160	PL59.56F	202,5 x 161,5	PL59.57N	200 x 160	PL59.58U	202,5 x 161,5	PL59.59A	202,5 x 161,5

 <b>NADIR</b>	Ht 92,5 Dpt 200 210 W 178	Ht 92,5 Dpt 203 213 W 178	Ht 92,5 Dpt 199,5 209,5 W 178	Ht 92,5 Dpt 202,7 212,7 W 178	Ht 92,5 Dpt 199,5 209,5 W 178	Ht 92,5 Dpt 199,5 209,5 W 178
						

bed base W	Code	internal dimensions	Code	internal dimensions	Code	internal dimensions	Code	internal dimensions	Code	internal dimensions	Code	internal dimensions
160 x 190 200	PL56.66Y	192,5 x 161,5	PL56.67E	190 x 160	PL56.68M	192,5 x 161,5	PL56.69T	190 x 160	PL56.70Q	192,5 x 161,5	PL56.71W	192,5 x 161,5
180 x 200	-	202,5 x 161,5	-	200 x 160	-	202,5 x 161,5	-	200 x 160	-	202,5 x 161,5	-	202,5 x 161,5

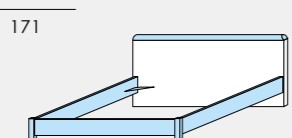
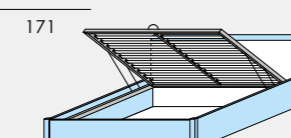
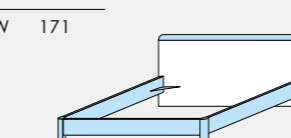
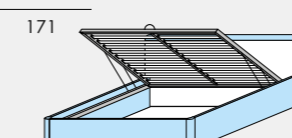
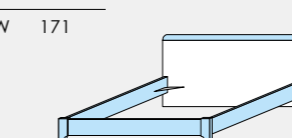
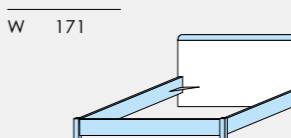
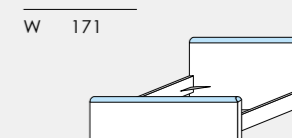
 <b>NORMALE</b>	Ht 79 Dpt 200 210 W 171	Ht 79 Dpt 203 213 W 171	Ht 79 Dpt 199,7 209,7 W 171	Ht 79 Dpt 203 213 W 171	Ht 79 Dpt 199,7 209,7 W 171	Ht 79 Dpt 199,7 209,7 W 171	Ht 79 Dpt 197,4 207,4 W 171
							

bed base W	Code	internal dimensions	Code	internal dimensions	Code	internal dimensions	Code	internal dimensions	Code	internal dimensions	Code	internal dimensions
160 x 190 200	PL43.62F	192,5 x 161,5	PL43.63N	190 x 160	PL43.64U	192,5 x 161,5	PL43.65A	190 x 160	PL56.72C	192,5 x 161,5	PL56.73K	192,5 x 161,5
180 x 200	-	202,5 x 161,5	-	200 x 160	-	202,5 x 161,5	-	200 x 160	-	202,5 x 161,5	P35.31FP	191 x 161,5
												201 x 161,5

 <b>SECTOR</b>	Ht 96 Dpt 200 210 W 172	Ht 96 Dpt 203 213 W 172	Ht 96 Dpt 199,5 209,5 W 172	Ht 96 Dpt 202,7 212,7 W 172	Ht 96 Dpt 199,5 209,5 W 172	Ht 96 Dpt 199,5 209,5 W 172	Ht 96 Dpt 197 207 W 172
							

bed base W	Code	internal dimensions	Code	internal dimensions	Code	internal dimensions	Code	internal dimensions	Code	internal dimensions	Code	internal dimensions
160 x 190 200	PL59.36V	192,5 x 161,5	PL59.37B	190 x 160	PL59.38H	192,5 x 161,5	PL59.39Q	190 x 160	PL59.40M	192,5 x 161,5	PL59.41T	192,5 x 161,5
180 x 200	-	202,5 x 161,5	-	200 x 160	-	202,5 x 161,5	-	200 x 160	-	202,5 x 161,5	PL59.42Z	191 x 161,5
												201 x 161,5

- Components in **CARCASE** colors
- Components in **GROUP 2** colors
- The headboard is available in two colours.

Shaped components available with contrasting edging.

FABRIC JENNY	0402	0403	0503	0900	0903	0905	0314	0303	0805	0706	0704	0601	0604
FABRIC KENYA	0014	0013	0016	0020	0019								
FALUX LEATHER TAPE	0111	0102	0603	0415	0503	0605	0700	0608	0901				

Mattresses, pillows and slatted bed base  
See back cover wing



When ordering, specify for bed base D 191 or 200.

# Double beds



## Headboards

	<b>ATLANTE bed frame</b> Without bed base. Only the bed base without feet can be installed.		<b>ATLANTE bed frame</b> With slatted, lifting bed base. Space inside container: W 163 Ht 19,5 Dpt 197/207		<b>GIOVE bed frame</b> Without bed base. Only the bed base without feet can be installed.		<b>GIOVE bed frame</b> With slatted, lifting bed base. Space inside container: W 163 Ht 19,5 Dpt 197/207		<b>MARTE bed frame</b> Without bed base. Only the bed base without feet can be installed.		<b>NETUNO bed frame</b> Without bed base. Only the bed base without feet can be installed.	<b>With footboard</b> Without bed base. Only the bed base without feet can be installed (unless otherwise indicated).
--	---	--	---	--	---	--	---	--	---	--	--	---



<b>TAIS</b>	Ht 93 Dpt 205 215 W 172		Ht 93 Dpt 204,5 214,5 W 172		Ht 93 Dpt 204,5 214,5 W 172		Ht 93 Dpt 204,5 214,5 W 172	
-------------	----------------------------------	--	--------------------------------------	--	--------------------------------------	--	--------------------------------------	--

bed base W	Code	internal dimensions	Code	internal dimensions	Code	internal dimensions	Code	internal dimensions
160 x 190 200	PL43.75F	192,5 x 161,5 202,5 x 161,5	PL43.76N	192,5 x 161,5 202,5 x 161,5	PL56.76D	192,5 x 161,5 202,5 x 161,5	PL56.77L	192,5 x 161,5 202,5 x 161,5
180 x 200	-	-	-	-	-	-	-	-



<b>VIRGO</b>	Ht 100 Dpt 200 210 W 177,5 197,5		Ht 100 Dpt 203 213 W 177,5 197,5		Ht 100 Dpt 199,5 209,5 W 177,5 197,5		Ht 100 Dpt 202,7 212,7 W 177,5 197,5		Ht 100 Dpt 199,5 209,5 W 177,5 197,5	
--------------	--	--	--	--	--	--	--	--	--	--

bed base W	Code	internal dimensions	Code	internal dimensions	Code	internal dimensions	Code	internal dimensions	Code	internal dimensions
160 x 190 200	PL43.20W	192,5 x 161,5 202,5 x 161,5	PL43.21C	190 x 160 200 x 160	PL43.22K	192,5 x 161,5 202,5 x 161,5	PL43.23R	190 x 160 200 x 160	PL56.54E	192,5 x 161,5 202,5 x 161,5
180 x 200	PL59.60X	202,5 x 181,5	PL59.61D	200 x 180	PL59.62L	202,5 x 181,5	PL59.63S	200 x 180	PL59.64Y	202,5 x 181,5
									PL56.55M	192,5 x 161,5 202,5 x 161,5
									PL59.65E	202,5 x 181,5



<b>Wooden bed frame</b>	Ht 34 Dpt 203 213 W 170 190		Ht 34 Dpt 204 214 W 170 190		Ht 32,5 Dpt 202 212 W 168,5 188,5		Ht 32,5 Dpt 202,7 212,7 W 168,5 188,5		Ht 32,5 Dpt 202 212 W 168,5 188,5	
-------------------------	---	--	---	--	---	--	---	--	---	--

bed base W	Code	internal dimensions	Code	internal dimensions	Code	internal dimensions	Code	internal dimensions	Code	internal dimensions
160 x 190 200	P35.51Q	194,5 x 161,5 204,5 x 161,5	P47.32V	190 x 160 200 x 160	PL43.94L	195 x 161,5 205 x 161,5	PL43.95S	190 x 160 200 x 160	PL56.88X	195 x 161,5 205 x 161,5
180 x 200	PL59.73X	204,5 x 181,5	PL59.74D	200 x 180	PL59.75L	205 x 181,5	PL59.76S	200 x 180	PL59.77Y	205 x 181,5
									PL56.89D	195 x 161,5 205 x 161,5
									PL59.78E	205 x 181,5

- Components in **GROUP 2 colors**
- Components in **GROUP 3 colors**
- Aluminium colour components
- The headboard is available in two colours.



When ordering, specify for bed base D 191 or 200.





# Double beds with rear housing space

- The double beds with rear housing space must be positioned against the wall.
- The rear housing space is equipped with adjustable feet Hf 0.7; it must be secured to the headboard during installation using the supplied hardware.
- The top of the rear housing space can be optionally equipped with: Cable hole, Wireless charging, Dual USB socket for which specific holes are needed (see holes for integrated technology).
- The headboard of the bed can be optionally equipped with led lighting to be secured to the rear with special screws.

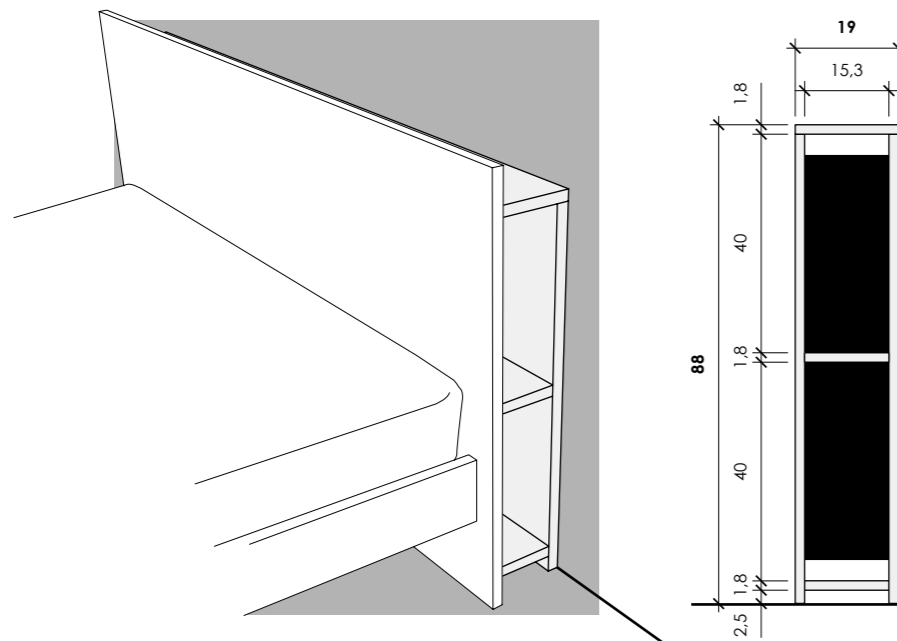

## Holes for built-in technology drilled by us on customer request

When placing the order for the bed, the rear housing space can be optionally equipped with integrated accessories (Cable hole, Wireless charging, Dual USB socket) for which specific holes need to be made on the top. One or more accessories can be selected. The methods used to make the holes are indicated at the side.

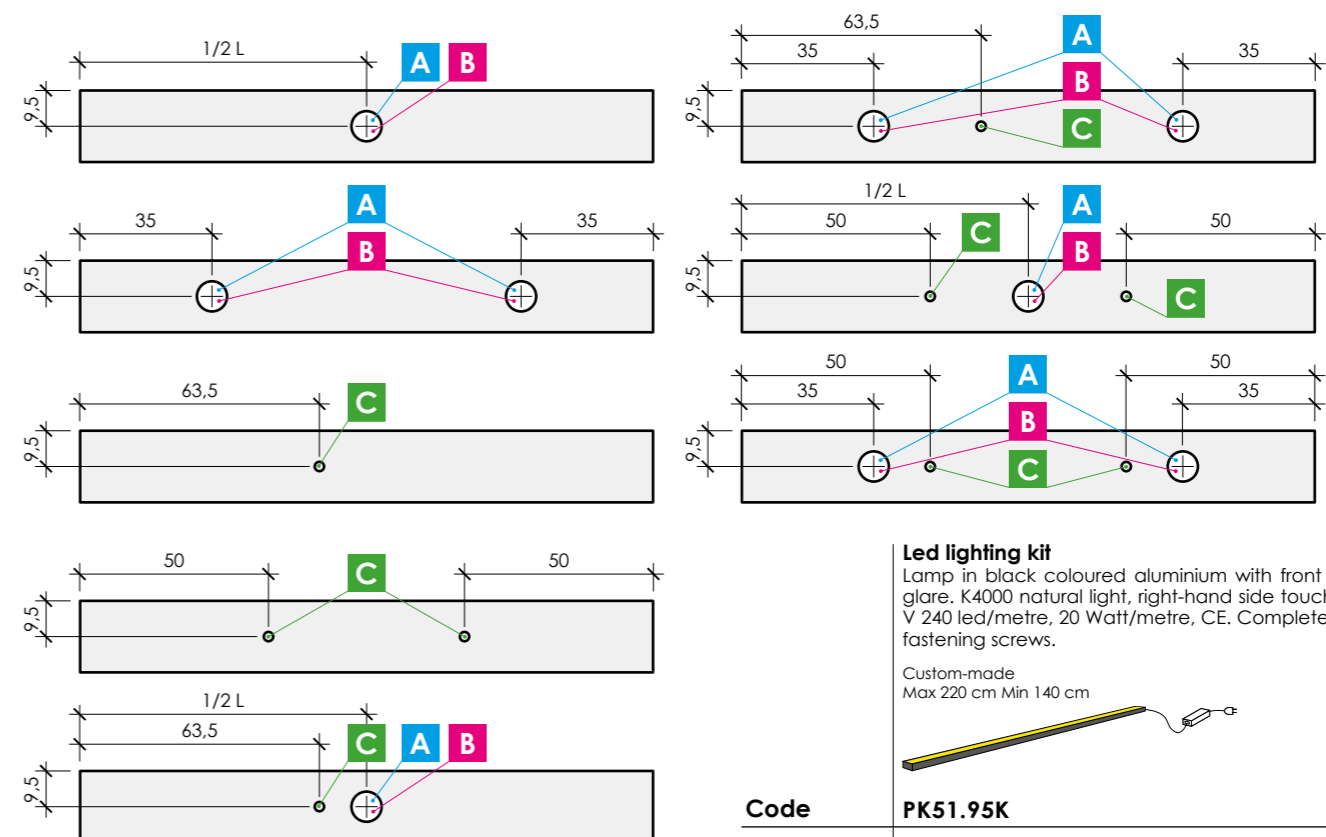
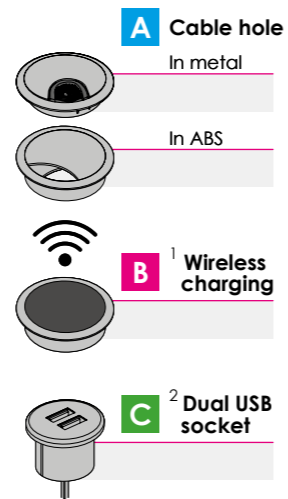

**Led lighting kit**  
Lamp in black coloured aluminium with front veil to reduce glare. K4000 natural light, right-hand side touch power-on, 24 V 240 led/metre, 20 Watt/metre, CE. Complete power kit and fastening screws.

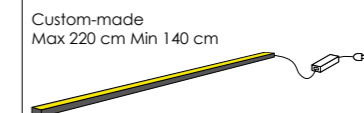

Code **PK51.95K**

## Headboards

	<b>ATLANTE bed frame</b> Without bed base. Only the bed base without feet can be installed.		<b>ATLANTE bed frame</b> With slatted, lifting bed base. Space inside container: W 163 Ht 19.5 Dpt 197/207		<b>GIOVE bed frame</b> Without bed base. Only the bed base without feet can be installed.		<b>GIOVE bed frame</b> With slatted, lifting bed base. Space inside container: W 163 Ht 19.5 Dpt 197/207		<b>MARTE bed frame</b> Without bed base. Only the bed base without feet can be installed.		<b>NETTUNO bed frame</b> Without bed base. Only the bed base without feet can be installed.	<b>With footboard</b> Without bed base. Only the bed base without feet can be installed (unless otherwise indicated).
--	---	--	---	--	---	--	---	--	---	--	---	---

## CUSHY

	Ht 101 Dpt 220,5 230,5 W 175		<b>Code</b> <b>PK51.83R</b>	internal dimensions 192,5 x 161,5 202,5 x 161,5		Ht 101 Dpt 223,5 233,5 W 175		<b>Code</b> <b>PK51.84X</b>	internal dimensions 190 x 160 200 x 160		Ht 101 Dpt 220 230 W 175		<b>Code</b> <b>PK51.85D</b>	internal dimensions 192,5 x 161,5 202,5 x 161,5		Ht 101 Dpt 223,2 233,2 W 175		<b>Code</b> <b>PK51.89E</b>	internal dimensions 190 x 160 200 x 160		Ht 101 Dpt 220 230 W 175		<b>Code</b> <b>PK51.90B</b>	internal dimensions 192,5 x 161,5 202,5 x 161,5		Ht 101 Dpt 220 230 W 175		<b>Code</b> <b>PK51.91H</b>	internal dimensions 192,5 x 161,5 202,5 x 161,5
--	---------------------------------------	--	-----------------------------	---	--	---------------------------------------	--	-----------------------------	---	--	-----------------------------------	--	-----------------------------	---	--	---------------------------------------	--	-----------------------------	---	--	-----------------------------------	--	-----------------------------	---	--	-----------------------------------	--	-----------------------------	---

## LEO

	Ht 100 Dpt 219 229 W 179,5		<b>Code</b> <b>PK51.86L</b>	internal dimensions 192,5 x 161,5 202,5 x 161,5		Ht 100 Dpt 222 232 W 179,5		<b>Code</b> <b>PK51.87S</b>	internal dimensions 190 x 160 200 x 160		Ht 100 Dpt 218,5 228,5 W 179,5		<b>Code</b> <b>PK51.88Y</b>	internal dimensions 192,5 x 161,5 202,5 x 161,5		Ht 100 Dpt 221,7 231,7 W 179,5		<b>Code</b> <b>PK51.92Q</b>	internal dimensions 190 x 160 200 x 160		Ht 100 Dpt 218,5 228,5 W 179,5		<b>Code</b> <b>PK51.93W</b>	internal dimensions 192,5 x 161,5 202,5 x 161,5		Ht 100 Dpt 218,5 228,5 W 179,5		<b>Code</b> <b>PK51.94C</b>	internal dimensions 192,5 x 161,5 202,5 x 161,5
--	-------------------------------------	--	-----------------------------	---	--	-------------------------------------	--	-----------------------------	---	--	---	--	-----------------------------	---	--	---	--	-----------------------------	---	--	---	--	-----------------------------	---	--	---	--	-----------------------------	---

- Components in **GROUP 2 colors**
- Components in **GROUP 3 colors**

Padded components with removable covers.

FABRIC JENNY	0402	0403	0503	0900	0903	0905	0314	0303	0805	0706	0704	0601	0604
FABRIC KENYA	0014	0013	0016	0020	0019								
FALUX LEATHER TAPE	0111	0102	0603	0415	0503	0605	0700	0608	0901				

- <sup>1</sup> Wireless charging: **Qi wireless charging standard**
- <sup>2</sup> Dual USB socket: **Output: 5V DC - 2,10A Max. (1 x 2,10A) (2 x 1,05A)**



When ordering, specify for bed base D 191 or 200.



# Double beds with rear housing space

## Headboards

	<b>ATLANTE bed frame</b> Without bed base. Only the bed base without feet can be installed.		<b>ATLANTE bed frame</b> With slatted, lifting bed base. Space inside container: W 163 Ht 19,5 Dpt 197/207		<b>GIOVE bed frame</b> Without bed base. Only the bed base without feet can be installed.		<b>GIOVE bed frame</b> With slatted, lifting bed base. Space inside container: W 163 Ht 19,5 Dpt 197/207		<b>MARTE bed frame</b> Without bed base. Only the bed base without feet can be installed.		<b>NETUNO bed frame</b> Without bed base. Only the bed base without feet can be installed.	<b>With footboard</b> Without bed base. Only the bed base without feet can be installed (unless otherwise indicated).
---	---	---	---	---	---	---	---	---	---	---	--	---

## MUSHY

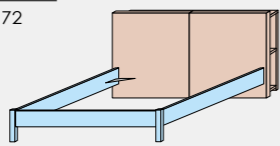
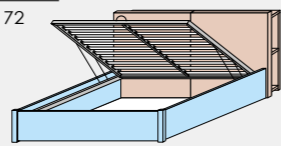
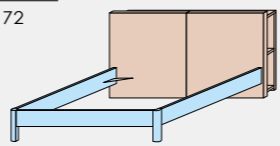
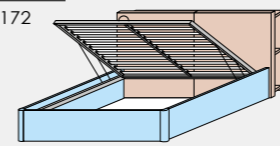
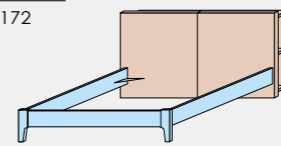
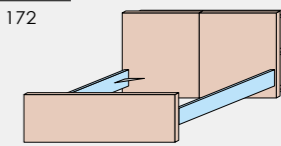
	Ht 95,5 Dpt 219 229 W 172		Ht 95,5 Dpt 222 232 W 172		Ht 95,5 Dpt 218,5 228,5 W 172		Ht 95,5 Dpt 221,7 231,7 W 172		Ht 95,5 Dpt 218,5 228,5 W 172		Ht 95,5 Dpt 218,5 228,5 W 172	
bed base <b>W</b>	<b>Code</b>	internal dimensions	<b>Code</b>	internal dimensions	<b>Code</b>	internal dimensions	<b>Code</b>	internal dimensions	<b>Code</b>	internal dimensions	<b>Code</b>	internal dimensions
160 x 190 200	PK51.96R	192,5 x 161,5 202,5 x 161,5	PK51.97X	190 x 160 200 x 160	PK51.98D	192,5 x 161,5 202,5 x 161,5	PK52.11U	190 x 160 200 x 160	PK52.12A	192,5 x 161,5 202,5 x 161,5	PK52.13G	192,5 x 161,5 202,5 x 161,5

## NADIR

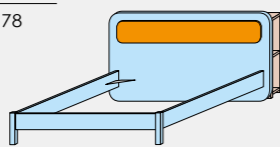
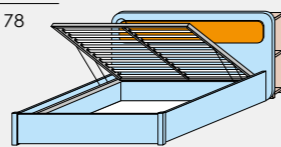
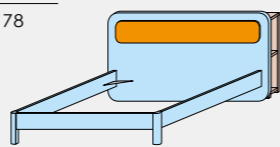
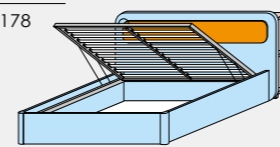
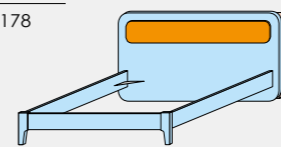
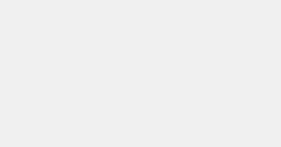

	Ht 92,5 Dpt 219 229 W 178		Ht 92,5 Dpt 222 232 W 178		Ht 92,5 Dpt 218,5 228,5 W 178		Ht 92,5 Dpt 221,7 231,7 W 178		Ht 92,5 Dpt 218,5 228,5 W 178		Ht 92,5 Dpt 218,5 228,5 W 178	
bed base <b>W</b>	<b>Code</b>	internal dimensions	<b>Code</b>	internal dimensions	<b>Code</b>	internal dimensions	<b>Code</b>	internal dimensions	<b>Code</b>	internal dimensions	<b>Code</b>	internal dimensions
160 x 190 200	PK51.99L	192,5 x 161,5 202,5 x 161,5	PK52.00G	190 x 160 200 x 160	PK52.01P	192,5 x 161,5 202,5 x 161,5	PK52.15V	190 x 160 200 x 160	PK52.16B	192,5 x 161,5 202,5 x 161,5	PK52.17H	192,5 x 161,5 202,5 x 161,5

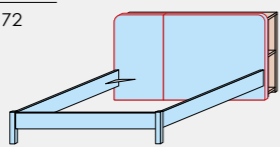
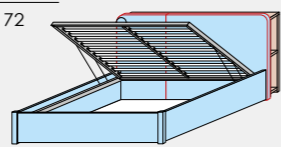
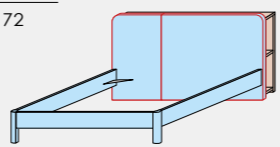
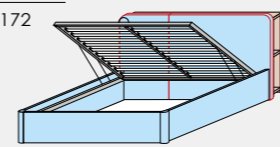
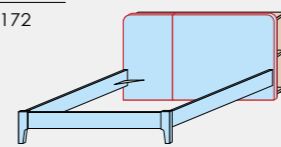
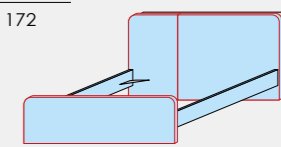
## SECTOR

	Ht 96 Dpt 219 229 W 172		Ht 96 Dpt 222 232 W 172		Ht 96 Dpt 218,5 228,5 W 172		Ht 96 Dpt 221,7 231,7 W 172		Ht 96 Dpt 218,5 228,5 W 172		Ht 96 Dpt 218,5 228,5 W 172	
bed base <b>W</b>	<b>Code</b>	internal dimensions	<b>Code</b>	internal dimensions	<b>Code</b>	internal dimensions	<b>Code</b>	internal dimensions	<b>Code</b>	internal dimensions	<b>Code</b>	internal dimensions
160 x 190 200	PK52.02V	192,5 x 161,5 202,5 x 161,5	PK52.03B	190 x 160 200 x 160	PK52.04H	192,5 x 161,5 202,5 x 161,5	PK52.18Q	190 x 160 200 x 160	PK52.19W	192,5 x 161,5 202,5 x 161,5	PK52.20T	192,5 x 161,5 202,5 x 161,5
											PK52.21Z	191 x 161,5 201 x 161,5

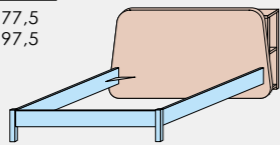
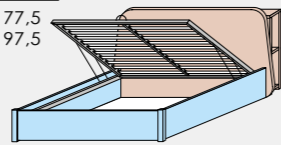
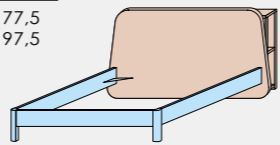
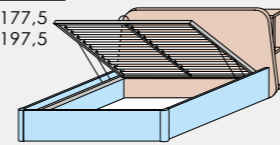
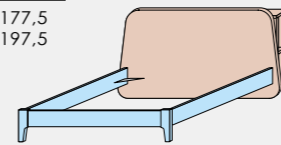
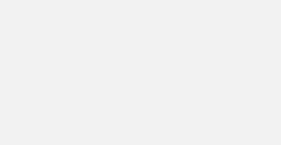
## VIRGO

	Ht 100 Dpt 219 229 W 177,5 197,5		Ht 100 Dpt 222 232 W 177,5 197,5		Ht 100 Dpt 218,5 228,5 W 177,5 197,5		Ht 100 Dpt 221,7 231,7 W 177,5 197,5		Ht 100 Dpt 218,5 228,5 W 177,5 197,5		Ht 100 Dpt 218,5 228,5 W 177,5 197,5	
bed base <b>W</b>	<b>Code</b>	internal dimensions	<b>Code</b>	internal dimensions	<b>Code</b>	internal dimensions	<b>Code</b>	internal dimensions	<b>Code</b>	internal dimensions	<b>Code</b>	internal dimensions
160 x 190 200	PK52.05Q	192,5 x 161,5 202,5 x 161,5	PK52.07C	190 x 160 200 x 160	PK52.09R	192,5 x 161,5 202,5 x 161,5	PK52.22F	190 x 160 200 x 160	PK52.24U	192,5 x 161,5 202,5 x 161,5	PK52.26G	192,5 x 161,5 202,5 x 161,5

-  Components in **GROUP 2 colors**
-  Components in **GROUP 3 colors**
-  The headboard is available in two colours.

 Shaped components available with contrasting edging.

	FABRIC JENNY	0402 0403 0503 0900 0903 0905 0314 0303 0805 0706 0704 0601 0604
	FABRIC KENYA	0014 0013 0016 0020 0019
	FAUX LEATHER TAPE	0111 0102 0603 0415 0503 0605 0700 0608 0901

When ordering, specify for bed base D 191 or 200.

Mattresses, pillows and slatted bed base  
See back cover wing



# Double beds with metal bed frame

Headboards are raised above the ground.

Headboards		With slatted bed base.		Headboards		With slatted bed base.	
<b>DIVA</b>	Ht 92 Dpt 196 W 172			<b>NADIR</b>	Ht 94,5 Dpt 196 W 178		
bed base W <b>160</b> x 190	<b>Code</b> <b>PL49.08P</b>	internal dimensions 193 x 168		bed base W <b>160</b> x 190	<b>Code</b> <b>PL57.12Z</b>	internal dimensions 193 x 168	
<b>ELFO</b>	Ht 77 Dpt 196 W 170			<b>NORMALE</b>	Ht 81 Dpt 196 W 171		
bed base W <b>160</b> x 190	<b>Code</b> <b>PL49.16F</b>	internal dimensions 193 x 168		bed base W <b>160</b> x 190	<b>Code</b> <b>PL49.14T</b>	internal dimensions 193 x 168	
<b>LEO</b>	Ht 102 Dpt 196 W 179,5			<b>SECTOR</b>	Ht 98 Dpt 196 W 172		
bed base W <b>160</b> x 190	<b>Code</b> <b>PL49.02Z</b>	internal dimensions 193 x 168		bed base W <b>160</b> x 190	<b>Code</b> <b>PL59.43F</b>	internal dimensions 193 x 168	
<b>MUSA</b>	Ht 92 Dpt 196 W 172			<b>TAIS</b>	Ht 95 Dpt 202 W 172		
bed base W <b>160</b> x 190	<b>Code</b> <b>PL49.10S</b>	internal dimensions 193 x 168		bed base W <b>160</b> x 190	<b>Code</b> <b>PL49.18U</b>	internal dimensions 193 x 168	

- Components in **CARCASE** colors
- Components in **GROUP 2** colors
- Components in **GROUP 3** colors
- Aluminium colour components
- The headboard is available in two colours.

- Shaped components available with contrasting edging.
- Padded components with removable covers.
- RW3Q RD5T CL1X B17A AL1A TR8A**
- B17A AL1A**
- Solid natural ash wood**  
Wood is a natural product and, as such, is subject to variations in color and grain. Differences in grain or color therefore do not constitute grounds for dispute.

Headboards		With slatted bed base.		Headboards		With slatted bed base.	
<b>VIRGO</b>	Ht 102 Dpt 196 W 177,5			<b>Metal bed frame</b>	Ht 29 Dpt 193 W 168		
bed base W <b>160</b> x 190	<b>Code</b> <b>PL49.00M</b>	internal dimensions 193 x 168		bed base W <b>160</b> x 190	<b>Code</b> <b>P35.79S</b>	internal dimensions 193 x 168	

# Double beds with SIGMA bed frame

Headboards		SIGMA bed frame Without bed base. Only the bed base without feet can be installed.		Headboards		SIGMA bed frame Without bed base. Only the bed base without feet can be installed.	
<b>COSY</b>	Ht 100 Dpt 204,5 W 178,5			<b>COSY</b>	Ht 100 Dpt 204,5 W 178,5		
bed base W <b>160</b> x 190	<b>Code</b> <b>PK52.28V</b>	internal dimensions 192 x 161,5		bed base W <b>160</b> x 190	<b>Code</b> <b>PK52.29B</b>	internal dimensions 192 x 161,5	

- FABRIC **JENNY**  
0402 0403 0503 0900 0903 0905 0314 0303 0805 0706 0704 0601 0604
- FABRIC **KENYA**  
0014 0013 0016 0020 0019
- FAUX LEATHER **TAPE**  
0111 0102 0603 0415 0503 0605 0700 0608 0901

p. 608 Accessories for double beds



# Padded double beds

With removable covers.

## Headboards



**ALBA**

	Ht 111 Dpt - 212 W 194		Ht 114,5 Dpt 207 W 194		Ht 119,5 Dpt 207 W 194	
bed base <b>W</b>	<b>Code</b>	internal dimensions	<b>Code</b>	internal dimensions	<b>Code</b>	internal dimensions
160 x 190 200	PK52.95P	- 204 x 161	PK52.96V	190 x 160 -	PK52.97B	190 x 160 -

**LINE**

	Ht 101 Dpt - 217 W 171		Ht 104,5 Dpt 212 W 171		Ht 109,5 Dpt 212 W 171	
bed base <b>W</b>	<b>Code</b>	internal dimensions	<b>Code</b>	internal dimensions	<b>Code</b>	internal dimensions
160 x 190 200	PK51.33P	- 204 x 161	PK51.34V	190 x 160 -	PK51.35B	190 x 160 -

**NARCISO**

	Ht 106 Dpt - 217 W 184		Ht 109,5 Dpt 212 W 184		Ht 114,5 Dpt 212 W 184	
bed base <b>W</b>	<b>Code</b>	internal dimensions	<b>Code</b>	internal dimensions	<b>Code</b>	internal dimensions
160 x 190 200	PL57.02U	- 204 x 161	PL57.03A	190 x 160 -	PL58.92X	190 x 160 -

**REVERSO**

	Ht 101 Dpt - 214 W 192,5		Ht 104,5 Dpt 209 W 192,5		Ht 109,5 Dpt 209 W 192,5	
bed base <b>W</b>	<b>Code</b>	internal dimensions	<b>Code</b>	internal dimensions	<b>Code</b>	internal dimensions
160 x 190 200	PK51.30U	- 204 x 161	PK51.31A	190 x 160 -	PK51.32G	190 x 160 -

## Headboards



**SLIM**

	Ht 101 Dpt - 213 W 171		Ht 104,5 Dpt 208 W 171		Ht 109,5 Dpt 208 W 171	
bed base <b>W</b>	<b>Code</b>	internal dimensions	<b>Code</b>	internal dimensions	<b>Code</b>	internal dimensions
160 x 190 200	PL56.92P	- 204 x 161	PL56.93V	190 x 160 -	PL58.94L	190 x 160 -

**SNUG**

	Ht 101 Dpt - 213 W 190		Ht 104,5 Dpt 208 W 190		Ht 109,5 Dpt 208 W 190	
bed base <b>W</b>	<b>Code</b>	internal dimensions	<b>Code</b>	internal dimensions	<b>Code</b>	internal dimensions
160 x 190 200	PL57.00F	- 204 x 161	PL57.01N	190 x 160 -	PL58.91R	190 x 160 -

**TIME**

	Ht 105 Dpt - 217 W 175		Ht 108,5 Dpt 212 W 175		Ht 113,5 Dpt 212 W 175	
bed base <b>W</b>	<b>Code</b>	internal dimensions	<b>Code</b>	internal dimensions	<b>Code</b>	internal dimensions
160 x 190 200	PK53.56C	- 204 x 161	PK53.57K	190 x 160 -	PK53.58R	190 x 160 -

**VERSO**

	Ht 101 Dpt - 214 W 184		Ht 104,5 Dpt 209 W 184		Ht 109,5 Dpt 209 W 184	
bed base <b>W</b>	<b>Code</b>	internal dimensions	<b>Code</b>	internal dimensions	<b>Code</b>	internal dimensions
160 x 190 200	PK51.27K	- 204 x 161	PK51.28R	190 x 160 -	PK51.29X	190 x 160 -

■ FABRIC JENNY 0402 0403 0503 0900 0903 0905 0314 0303 0805 0706 0704 0601 0604  
■ FABRIC KENYA 0014 0013 0016 0020 0019  
■ FALIX LEATHER TAPE 0111 0102 0603 0415 0503 0605 0700 0608 0901  
● B17A GZ8T GV7A CQ3Q B14B BO7H CP4J RB7Y CR5T AL1A  
● RW3Q RD5T CL1X B17A AL1A TR8A

Beds with contrasting seams. See the summary table at the top of the price list.





# UNIQUE padded double bed

With removable cover.



With structural bed base.

Ht 100  
Dpt 227  
W 180

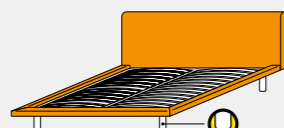

bed base W	Code	internal dimensions
160 x 200	PK53.59X	200 x 160

# DARSENA padded double bed

With removable cover.



Bed frame upholstered on 4 sides laid against the headboard. Headboard panels Th 1.8; these are anchored to the wall with included adjustable hangers Th 0.8; panel shelves Th 2.5. Optional upholstered headboard cushion Th 5; this can be mounted on the panels for headboard W 120 either singularly (top or bottom) or in vertical succession. Assembly by the client using the supplied hardware.

Padded bed frame

With slatted bed base.

Ht 36,5  
Dpt 199  
W 171

With slatted, lifting bed base.

Ht 36,5  
Dpt 205  
W 171

Space inside container:  
W 163  
Ht 19,5  
Dpt 197

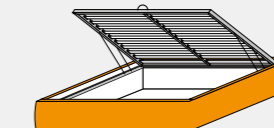

bed base W	Code	internal dimensions	Code	internal dimensions
160 x 190	PK53.60U	190 x 160	PK53.61A	190 x 160

Examples of headboard panelling compositions

Ht 96  
Dpt 28,6

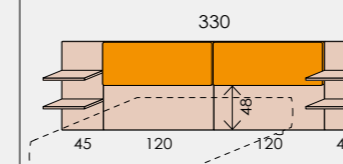

Code **PK53.62G**

Ht 192  
Dpt 7,6

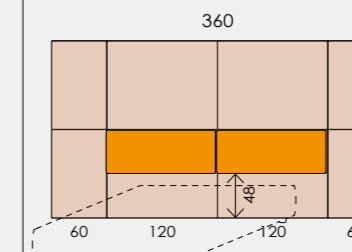

Code **PK53.63P**

Ht 192  
Dpt 28,6

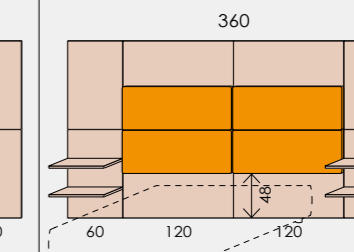

Code **PK53.64V**

Components for headboard panelling

Smooth headboard panels

Ht 96  
Dpt 2,6

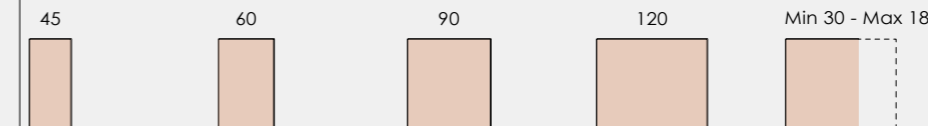

Code **PK53.65B** **PK53.66H** **PK53.67Q** **PK53.68W** **PK53.69C**

Panels for headboard with shelves

Ht 96  
Dpt 28,6

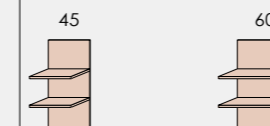

Code **PK53.70Z** **PK53.71F**

Cushion for panel W 120

Ht 47,6  
W 119,6  
Th 5



Code **PK53.72N**

Components in GROUP 3 colors  
RW3Q RD5T CL1X BI7A AL1A TR8A



# Padded double beds ECOCHIC



## Headboards

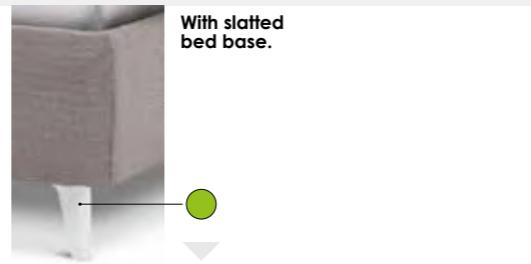
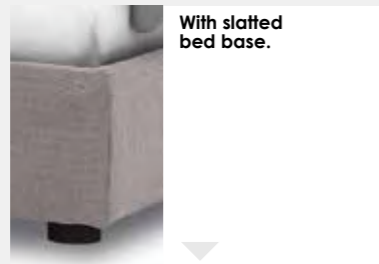

## ADAGIO

Ht 108  
Dpt 218  
225  
W 180

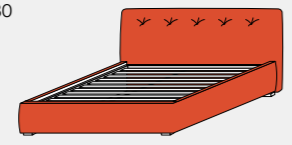

Ht 108  
Dpt 218  
225  
W 180

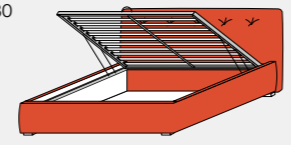

Ht 112  
Dpt 218  
225  
W 180

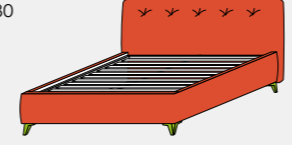

Ht 112  
Dpt 218  
225  
W 180

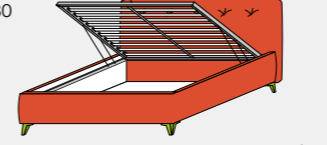

bed base W	Code	internal dimensions	Code	internal dimensions	Code	internal dimensions	Code	internal dimensions
160 x <sup>190</sup> / <sub>200</sub>	PK53.80E	195 x 162 202 x 162	PK53.81M	190 x 160 200 x 160	PK53.82T	195 x 162 202 x 162	PK53.83Z	190 x 160 200 x 160



## GALAXY

Ht 109  
Dpt 208  
215  
W 179

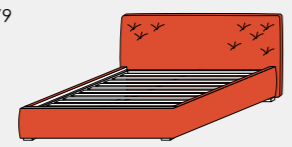

Ht 109  
Dpt 208  
215  
W 179

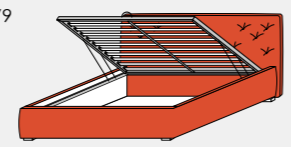

Ht 113  
Dpt 208  
215  
W 179

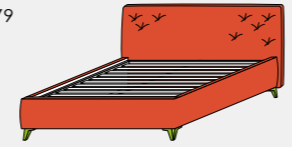

Ht 113  
Dpt 208  
215  
W 179

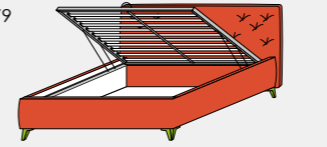

bed base W	Code	internal dimensions	Code	internal dimensions	Code	internal dimensions	Code	internal dimensions
160 x <sup>190</sup> / <sub>200</sub>	PL57.08H	195 x 162 202 x 162	PL57.09Q	190 x 160 200 x 160	PL62.49T	195 x 162 202 x 162	PL62.50Q	190 x 160 200 x 160



## GALLERY

Ht 95  
Dpt 202  
209  
W 176

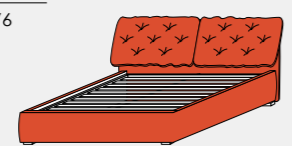

Ht 95  
Dpt 202  
209  
W 176

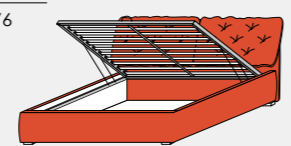

Ht 99  
Dpt 202  
209  
W 176

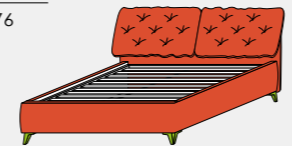

Ht 99  
Dpt 202  
209  
W 176

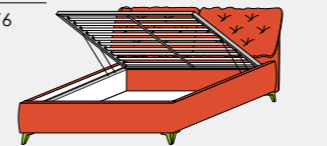

bed base W	Code	internal dimensions	Code	internal dimensions	Code	internal dimensions	Code	internal dimensions
160 x <sup>190</sup> / <sub>200</sub>	PL57.05P	195 x 162 202 x 162	PL43.04M	190 x 160 200 x 160	PL62.51W	195 x 162 202 x 162	PL62.52C	190 x 160 200 x 160

FABRIC ECOCHIC: Z80B, Z81G, Z83P, Z84S, Z85V, Z82L

FALIX LEATHER ECOCHIC: Z20B, Z41G, Z21R, Z62R, Z64X, Z63U, Z79Y

B17A, GZ8T, GV7A, CQ3Q, B14B, BO7H, CP4J, RB7Y, CR5T, AL1A

⚠ Padded components with not removable covers.

Mattresses, pillows and slatted bed base  
See back cover wing



# Padded double beds ECOCHIC



## Headboards

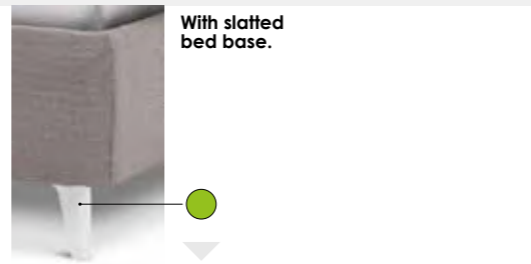
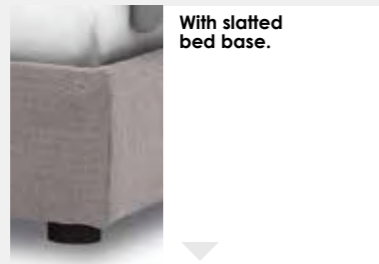

Ht 37  
Dpt 201  
208  
W 168

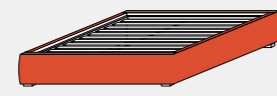

Ht 37  
Dpt 201  
208  
W 168

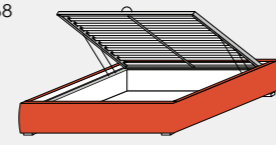

Ht 41  
Dpt 201  
208  
W 168

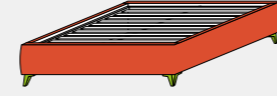

Ht 41  
Dpt 201  
208  
W 168

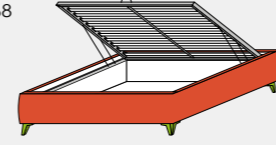

bed base W	Code	internal dimensions	Code	internal dimensions	Code	internal dimensions	Code	internal dimensions
160 x <sup>190</sup> / <sub>200</sub>	PL62.57L	195 x 162 202 x 162	PL62.58S	190 x 160 197 x 160	PL62.59Y	195 x 162 202 x 162	PL62.60V	190 x 160 197 x 160



Ht 107 (Ht 114,5 for W 218)  
Dpt 208  
215  
W 158  
168  
178  
198  
218

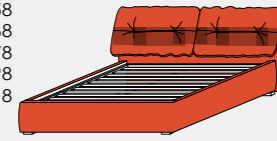

Ht 107 (Ht 114,5 for W 218)  
Dpt 208  
215  
W 158  
168  
178  
198  
218

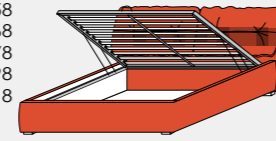

Ht 111 (Ht 118,5 for W 218)  
Dpt 208  
215  
W 158  
168  
178  
198  
218

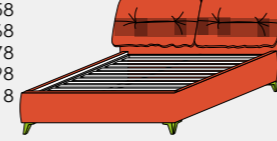

Ht 111 (Ht 118,5 for W 218)  
Dpt 208  
215  
W 158  
168  
178  
198  
218

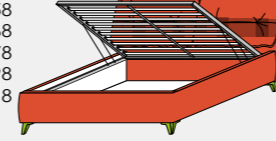

bed base W	Code	internal dimensions	Code	internal dimensions	Code	internal dimensions	Code	internal dimensions
140 x 200	PK53.84F	202 x 142	PK53.85N	200 x 140	PK53.86U	202 x 142	PK53.87A	200 x 140
150 x 200	PK53.88G	202 x 152	PK53.89P	200 x 150	PK53.90L	202 x 152	PK53.91S	200 x 150
160 x <sup>190</sup> / <sub>200</sub>	PL62.41R	195 x 162 202 x 162	PL62.42X	190 x 160 200 x 160	PL62.43D	195 x 162 202 x 162	PL62.44L	190 x 160 200 x 160
180 x 200	PK53.92Y	202 x 182	PK53.93E	200 x 180	PK53.94M	202 x 182	PK53.95T	200 x 180
200 x 200	PK53.96Z	202 x 202	PK53.97F	200 x 200	PK53.98N	202 x 202	PK53.99U	200 x 200



Ht 112  
Dpt 208  
215  
W 185

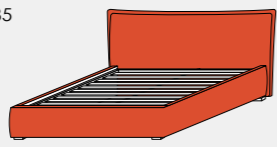

Ht 112  
Dpt 208  
215  
W 185

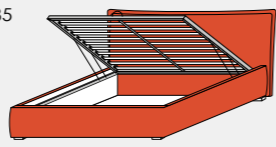

Ht 116  
Dpt 208  
215  
W 185

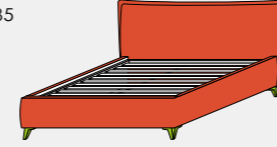

Ht 116  
Dpt 208  
215  
W 185

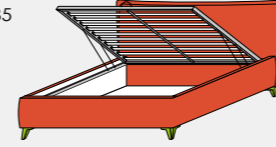

bed base W	Code	internal dimensions	Code	internal dimensions	Code	internal dimensions	Code	internal dimensions
160 x <sup>190</sup> / <sub>200</sub>	PL57.10M	195 x 162 202 x 162	PL57.11T	190 x 160 200 x 160	PL62.53K	195 x 162 202 x 162	PL62.54R	190 x 160 200 x 160

**FABRIC ECOCHIC**

**FALIX LEATHER ECOCHIC**

B17A GZ8T GV7A CQ3Q B14B BO7H CP4J RB7Y CR5T AL1A

Padded components with not removable covers.  
 Padded components with removable covers.

Beds with contrasting seams.  
**See the summary table at the top of the price list.**  
 Delivery approximately 5 weeks from order receipt.



# Padded double beds ECOCHIC

## Headboards



## TETRIS

Ht 109  
Dpt 205  
212  
W 178

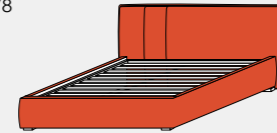

Code

**PL62.45S**

internal dimensions

195 x 162  
202 x 162

Ht 109  
Dpt 205  
212  
W 178

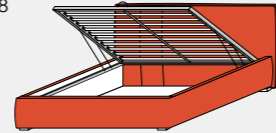

Code

**PL62.46Y**

internal dimensions

190 x 160  
200 x 160

Ht 113  
Dpt 205  
212  
W 178

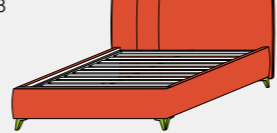

Code

**PL62.47E**

internal dimensions

195 x 162  
202 x 162

Ht 113  
Dpt 205  
212  
W 178

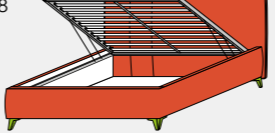

Code

**PL62.48M**

internal dimensions

190 x 160  
200 x 160



## TWIN

Ht 98 (Ht 105,5 for W 219)  
Dpt 206  
213  
W 159  
169  
179  
199  
219

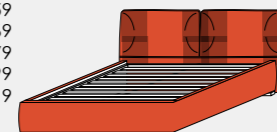

Code

**PK54.50T**

internal dimensions

202 x 142

Ht 98 (Ht 105,5 for W 219)  
Dpt 206  
213  
W 159  
169  
179  
199  
219

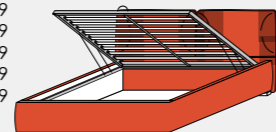

Code

**PK54.54U**

internal dimensions

200 x 140

Ht 102 (Ht 109,5 for W 219)  
Dpt 206  
213  
W 159  
169  
179  
199  
219

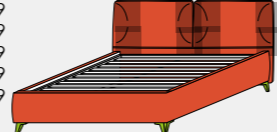

Code

**PK54.58V**

internal dimensions

202 x 142

Ht 102 (Ht 109,5 for W 219)  
Dpt 206  
213  
W 159  
169  
179  
199  
219

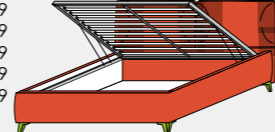

Code

**PK54.62M**

internal dimensions

200 x 140

bed base W

**140** x 200

**150** x 200

**160** x 200

**180** x 200

**200** x 200

Code

**PK54.51Z**

**PL57.06V**

**PK54.52F**

**PK54.53N**

internal dimensions

202 x 152

195 x 162

202 x 162

202 x 182

202 x 202

Code

**PK54.55A**

**PL43.02Y**

**PK54.56G**

**PK54.57P**

internal dimensions

200 x 150

190 x 160

200 x 160

200 x 180

200 x 200

Code

**PK54.59B**

**PL62.55X**

**PK54.60Y**

**PK54.61E**

internal dimensions

202 x 152

195 x 162

202 x 162

202 x 182

202 x 202

Code

**PK54.63T**

**PL62.56D**

**PK54.64Z**

**PK54.65F**

internal dimensions

200 x 150

190 x 160

200 x 160

200 x 180

200 x 200

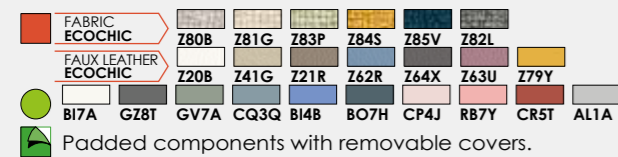

🔴 Beds with contrasting seams. See the summary table at the top of the price list.  
🕒 Delivery approximately 5 weeks from order receipt.



# Accessories for double beds

## Fabric (JENNY - KENYA) and faux leather (TAPE) covers

For headboards  
To the ground

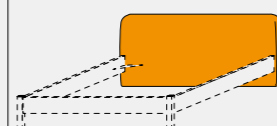

Suspended

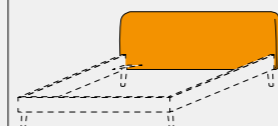

	Code	Code
COSY	PK52.30Y	PK52.31E
CUSHY	PK52.37U	-

## Fabric (JENNY - KENYA) and faux leather (TAPE) covers

For beds

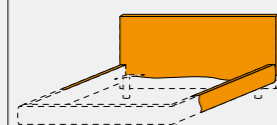

For beds  
with lifting base

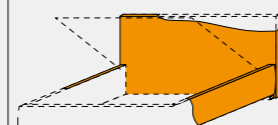

	Code	Code
ALBA	PK54.70D	PK54.71L
LINE	PK51.40Z	PK51.41F
NARCISO	PL57.26F	PL57.35E
REVERSO	PK51.38W	PK51.39C
SLIM	PL57.21Y	PL57.30X
SNUG	PL57.25Z	PL57.34Y
TIME	PK54.72S	PK54.73Y
UNIQUE	PK54.74E	-
VERSO	PK51.36H	PK51.37Q

## ECOCHIC fabric and faux leather covers

When ordering, specify for bed base Dpt 190 or 200

For beds and beds  
with lifting base

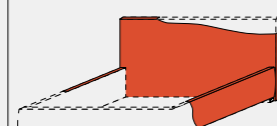

	for bed W	Code	Dpt 190	Dpt 200
KANT	160	PL58.76N		
PAD	160	PL58.74Z		
TETRIS	160	PL58.73T		
TWIN	140	PK54.75M		
	150	PK54.76T		
	160	PL58.75F		
	180	PK54.77Z		
	200	PK54.78F		

## Fabric/faux leather Customised W

Ht 140  
W min. 40



Code	PL57.36M	H26.59D	P48.48L
------	----------	---------	---------

## Pair of feet

Ht 23,7  
Ø 8 \* Ø 7 in the Trasparente (TR8A) version

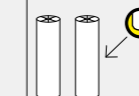

## Pair of brackets for fitting headboard to metal bed frame

Aluminium colour

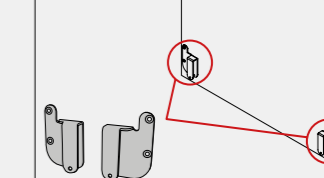

## Led lighting kit for bed headboards

With support panel W 140 x Ht 22 Th 1.5, led adhesive strip with 2 light switches and cables.

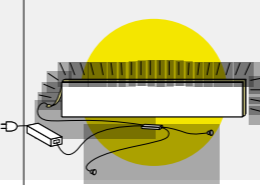

Code	PL43.98M	P26.86F
------	----------	---------

## Led light

For mounting on headboards  
1.2 Watt  
12V DC  
Current 90mA  
Alluminio colour

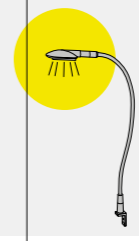

## Rear headboard console table

Can be positioned behind the bed headboard as an organiser table. Complete with hardware for wall mounting and adjustable feet.

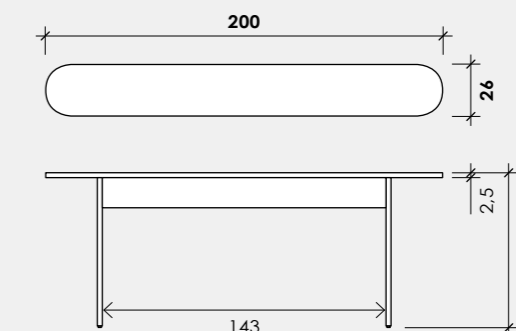
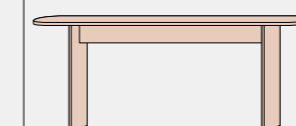

Code	PK54.80K
------	----------

## End-of-bed bench

Can be positioned at the foot of the bed, complete with removable padded cushion Th 5 and adjustable feet.

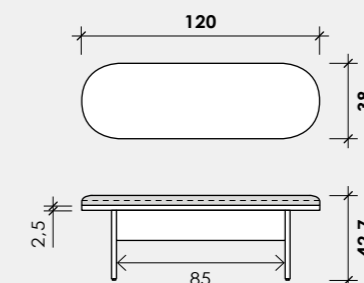
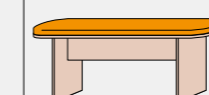

Code	PK54.81R
------	----------

Components in GROUP 3 colors

Beds with contrasting seams. See the summary table at the top of the price list.

RW3Q RD5T CL1X B17A AL1A TR8A

FABRIC JENNY	0402	0403	0503	0900	0903	0905	0314	0303	0805	0706	0704	0601	0604
FABRIC KENYA	0014	0013	0016	0020	0019								
FAUX LEATHER TAPE	0111	0102	0603	0415	0503	0605	0700	0608	0901				
FABRIC ECOCHIC	Z80B	Z81G	Z83P	Z84S	Z85V	Z82L							
FAUX LEATHER ECOCHIC	Z20B	Z41G	Z21R	Z62R	Z64X	Z63U	Z79Y						



GROUP 1 colors	Rovere Dorian <b>RD5T</b>	Rovere white <b>RW3Q</b>	Noce naturale <b>NN7H</b>	Eucalipto <b>CL1X</b>	Domy <b>DM7P</b>	Bianco UV <b>BU3Q</b>
	Ciliegio bianco <b>CB6K</b>	Malta <b>ML7H</b>	Feltro <b>FL8X</b>	Cemento Masdar <b>CM3Q</b>	Blu indaco <b>BI4B</b>	
	Noce <b>NC4B</b>	Desert <b>DS9L</b>	Canapa <b>CN1X</b>	Moka <b>MK6B</b>	Cipria <b>CP4J</b>	
	Bianco opaco <b>BI7A</b>	Grigio Dorian <b>GL4R</b>	Basalto <b>BS5T</b>	Grigio titanio <b>GZ8T</b>	Rosa bubble <b>RB7Y</b>	
	Agave <b>GV7A</b>	Verde Alpi <b>VA5T</b>	Cadaques <b>CQ3Q</b>	Giallo zafferano <b>GZ8A</b>		
	Blu opale <b>BO7H</b>			Corallo <b>CR5T</b>		

Types and colors FRONT	ONE	<table border="1"> <tr> <td>Rovere white <b>RW3Q</b></td> <td>Rovere Dorian <b>RD5T</b></td> <td>Ciliegio bianco <b>CB6K</b></td> <td>Noce naturale <b>NN7H</b></td> <td>Noce <b>NC4B</b></td> <td>Eucalipto <b>CL1X</b></td> <td>Malta <b>ML7H</b></td> </tr> <tr> <td>Feltro <b>FL8X</b></td> <td>Cemento Masdar <b>CM3Q</b></td> <td>Bianco opaco <b>BI7A</b></td> <td>Desert <b>DS9L</b></td> <td>Canapa <b>CN1X</b></td> <td>Moka <b>MK6B</b></td> <td>Grigio Dorian <b>GL4R</b></td> </tr> <tr> <td>Basalto <b>BS5T</b></td> <td>Grigio titanio <b>GZ8T</b></td> <td>Domy <b>DM7P</b></td> <td>Agave <b>GV7A</b></td> <td>Verde Alpi <b>VA5T</b></td> <td>Cadaques <b>CQ3Q</b></td> <td>Blu indaco <b>BI4B</b></td> </tr> <tr> <td>Blu opale <b>BO7H</b></td> <td>Cipria <b>CP4J</b></td> <td>Rosa bubble <b>RB7Y</b></td> <td>Giallo zafferano <b>GZ8A</b></td> <td>Corallo <b>CR5T</b></td> <td></td> <td></td> </tr> </table>							Rovere white <b>RW3Q</b>	Rovere Dorian <b>RD5T</b>	Ciliegio bianco <b>CB6K</b>	Noce naturale <b>NN7H</b>	Noce <b>NC4B</b>	Eucalipto <b>CL1X</b>	Malta <b>ML7H</b>	Feltro <b>FL8X</b>	Cemento Masdar <b>CM3Q</b>	Bianco opaco <b>BI7A</b>	Desert <b>DS9L</b>	Canapa <b>CN1X</b>	Moka <b>MK6B</b>	Grigio Dorian <b>GL4R</b>	Basalto <b>BS5T</b>	Grigio titanio <b>GZ8T</b>	Domy <b>DM7P</b>	Agave <b>GV7A</b>	Verde Alpi <b>VA5T</b>	Cadaques <b>CQ3Q</b>	Blu indaco <b>BI4B</b>	Blu opale <b>BO7H</b>	Cipria <b>CP4J</b>	Rosa bubble <b>RB7Y</b>	Giallo zafferano <b>GZ8A</b>	Corallo <b>CR5T</b>		
		Rovere white <b>RW3Q</b>	Rovere Dorian <b>RD5T</b>	Ciliegio bianco <b>CB6K</b>	Noce naturale <b>NN7H</b>	Noce <b>NC4B</b>	Eucalipto <b>CL1X</b>	Malta <b>ML7H</b>																												
Feltro <b>FL8X</b>	Cemento Masdar <b>CM3Q</b>	Bianco opaco <b>BI7A</b>	Desert <b>DS9L</b>	Canapa <b>CN1X</b>	Moka <b>MK6B</b>	Grigio Dorian <b>GL4R</b>																														
Basalto <b>BS5T</b>	Grigio titanio <b>GZ8T</b>	Domy <b>DM7P</b>	Agave <b>GV7A</b>	Verde Alpi <b>VA5T</b>	Cadaques <b>CQ3Q</b>	Blu indaco <b>BI4B</b>																														
Blu opale <b>BO7H</b>	Cipria <b>CP4J</b>	Rosa bubble <b>RB7Y</b>	Giallo zafferano <b>GZ8A</b>	Corallo <b>CR5T</b>																																
matte		<table border="1"> <tr> <td>Bianco UV <b>BU3Q</b></td> <td></td> <td></td> <td></td> <td></td> <td></td> <td></td> </tr> </table>							Bianco UV <b>BU3Q</b>																											
Bianco UV <b>BU3Q</b>																																				
glossy		<table border="1"> <tr> <td>Rovere white <b>RW3Q</b></td> <td>Rovere Dorian <b>RD5T</b></td> <td>Ciliegio bianco <b>CB6K</b></td> <td>Noce naturale <b>NN7H</b></td> <td>Noce <b>NC4B</b></td> <td>Eucalipto <b>CL1X</b></td> <td>Malta <b>ML7H</b></td> </tr> <tr> <td>Feltro <b>FL8X</b></td> <td>Cemento Masdar <b>CM3Q</b></td> <td>Bianco opaco <b>BI7A</b></td> <td>Desert <b>DS9L</b></td> <td>Canapa <b>CN1X</b></td> <td>Moka <b>MK6B</b></td> <td>Grigio Dorian <b>GL4R</b></td> </tr> <tr> <td>Basalto <b>BS5T</b></td> <td>Grigio titanio <b>GZ8T</b></td> <td>Domy <b>DM7P</b></td> <td>Agave <b>GV7A</b></td> <td>Verde Alpi <b>VA5T</b></td> <td>Cadaques <b>CQ3Q</b></td> <td>Blu indaco <b>BI4B</b></td> </tr> <tr> <td>Blu opale <b>BO7H</b></td> <td>Cipria <b>CP4J</b></td> <td>Rosa bubble <b>RB7Y</b></td> <td>Giallo zafferano <b>GZ8A</b></td> <td>Corallo <b>CR5T</b></td> <td></td> <td></td> </tr> </table>							Rovere white <b>RW3Q</b>	Rovere Dorian <b>RD5T</b>	Ciliegio bianco <b>CB6K</b>	Noce naturale <b>NN7H</b>	Noce <b>NC4B</b>	Eucalipto <b>CL1X</b>	Malta <b>ML7H</b>	Feltro <b>FL8X</b>	Cemento Masdar <b>CM3Q</b>	Bianco opaco <b>BI7A</b>	Desert <b>DS9L</b>	Canapa <b>CN1X</b>	Moka <b>MK6B</b>	Grigio Dorian <b>GL4R</b>	Basalto <b>BS5T</b>	Grigio titanio <b>GZ8T</b>	Domy <b>DM7P</b>	Agave <b>GV7A</b>	Verde Alpi <b>VA5T</b>	Cadaques <b>CQ3Q</b>	Blu indaco <b>BI4B</b>	Blu opale <b>BO7H</b>	Cipria <b>CP4J</b>	Rosa bubble <b>RB7Y</b>	Giallo zafferano <b>GZ8A</b>	Corallo <b>CR5T</b>		
Rovere white <b>RW3Q</b>	Rovere Dorian <b>RD5T</b>	Ciliegio bianco <b>CB6K</b>	Noce naturale <b>NN7H</b>	Noce <b>NC4B</b>	Eucalipto <b>CL1X</b>	Malta <b>ML7H</b>																														
Feltro <b>FL8X</b>	Cemento Masdar <b>CM3Q</b>	Bianco opaco <b>BI7A</b>	Desert <b>DS9L</b>	Canapa <b>CN1X</b>	Moka <b>MK6B</b>	Grigio Dorian <b>GL4R</b>																														
Basalto <b>BS5T</b>	Grigio titanio <b>GZ8T</b>	Domy <b>DM7P</b>	Agave <b>GV7A</b>	Verde Alpi <b>VA5T</b>	Cadaques <b>CQ3Q</b>	Blu indaco <b>BI4B</b>																														
Blu opale <b>BO7H</b>	Cipria <b>CP4J</b>	Rosa bubble <b>RB7Y</b>	Giallo zafferano <b>GZ8A</b>	Corallo <b>CR5T</b>																																
		<p>Specify the color of the CLUB handle</p> <table border="1"> <tr> <td>Bianco opaco <b>BI7A</b></td> <td>Desert <b>DS9L</b></td> <td>Canapa <b>CN1X</b></td> <td>Moka <b>MK6B</b></td> <td>Grigio Dorian <b>GL4R</b></td> <td>Basalto <b>BS5T</b></td> <td>Grigio titanio <b>GZ8T</b></td> </tr> <tr> <td>Domy <b>DM7P</b></td> <td>Agave <b>GV7A</b></td> <td>Verde Alpi <b>VA5T</b></td> <td>Cadaques <b>CQ3Q</b></td> <td>Blu indaco <b>BI4B</b></td> <td>Blu opale <b>BO7H</b></td> <td>Cipria <b>CP4J</b></td> </tr> <tr> <td>Rosa bubble <b>RB7Y</b></td> <td>Giallo zafferano <b>GZ8A</b></td> <td>Corallo <b>CR5T</b></td> <td></td> <td></td> <td></td> <td></td> </tr> </table>							Bianco opaco <b>BI7A</b>	Desert <b>DS9L</b>	Canapa <b>CN1X</b>	Moka <b>MK6B</b>	Grigio Dorian <b>GL4R</b>	Basalto <b>BS5T</b>	Grigio titanio <b>GZ8T</b>	Domy <b>DM7P</b>	Agave <b>GV7A</b>	Verde Alpi <b>VA5T</b>	Cadaques <b>CQ3Q</b>	Blu indaco <b>BI4B</b>	Blu opale <b>BO7H</b>	Cipria <b>CP4J</b>	Rosa bubble <b>RB7Y</b>	Giallo zafferano <b>GZ8A</b>	Corallo <b>CR5T</b>											
Bianco opaco <b>BI7A</b>	Desert <b>DS9L</b>	Canapa <b>CN1X</b>	Moka <b>MK6B</b>	Grigio Dorian <b>GL4R</b>	Basalto <b>BS5T</b>	Grigio titanio <b>GZ8T</b>																														
Domy <b>DM7P</b>	Agave <b>GV7A</b>	Verde Alpi <b>VA5T</b>	Cadaques <b>CQ3Q</b>	Blu indaco <b>BI4B</b>	Blu opale <b>BO7H</b>	Cipria <b>CP4J</b>																														
Rosa bubble <b>RB7Y</b>	Giallo zafferano <b>GZ8A</b>	Corallo <b>CR5T</b>																																		
		<table border="1"> <tr> <td>Trasparente <b>TR9M</b></td> <td>Trasparente fumé <b>FT8P</b></td> <td>Stop-sol <b>ST6P</b></td> <td>Specchio <b>SP7L</b></td> <td></td> <td></td> <td></td> </tr> </table> <p>Specify the color of the aluminum frame</p> <table border="1"> <tr> <td>Alluminio <b>AL1A</b></td> <td>Titan grey <b>TG7H</b></td> </tr> </table>							Trasparente <b>TR9M</b>	Trasparente fumé <b>FT8P</b>	Stop-sol <b>ST6P</b>	Specchio <b>SP7L</b>				Alluminio <b>AL1A</b>	Titan grey <b>TG7H</b>																			
Trasparente <b>TR9M</b>	Trasparente fumé <b>FT8P</b>	Stop-sol <b>ST6P</b>	Specchio <b>SP7L</b>																																	
Alluminio <b>AL1A</b>	Titan grey <b>TG7H</b>																																			

Modular units, Wall units and Sideboards

Modular units and wall units - Technical information	612
OPTIONAL for modular units and wall units	614
Floor/support Modular units Dpt 56.3	616
L corner Modular units Dpt 56.3 - W 90	626
R corner Modular units Dpt 56.3 - W 90	627
Floor/support Modular units Dpt 45	628
L corner Modular units Dpt 45 - W 90	638
R corner Modular units Dpt 45 - W 90	639
Floor/support Modular units Dpt 32.5	640
L corner Modular units Dpt 32.5 - W 90	650
R corner Modular units Dpt 32.5 - W 90	651
Hanging Modular units Dpt 45	652
Hanging Modular units Dpt 32.5	656
Wall units Dpt 32.5	660
Tops and bases for modular units and wall units	662
Adjustable feet for modular units	666
ROUND desk Ht 72 - Dpt 45.6	667
Accessories for modular units and wall units	668
Sideboards Dpt 45.6 with outer box Th 1.8	670
Sideboards Dpt 45.8 with outer box Th 2.5	678
Accessories for sideboards with outer box	686
INSIDE sideboards Dpt 54	687



# Modular units and wall units - Technical information

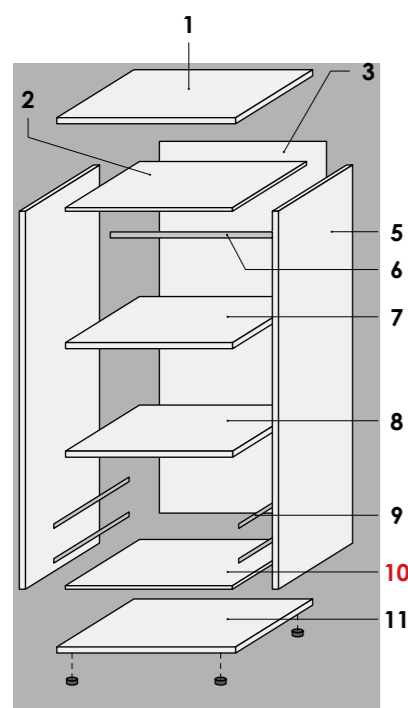

## Floor/Support Modular units

Dimensions (not including top, base or feet):

**Dpt** 56,3-45-32,5

**W** 45-60-90

**Ht** 16-32-64-96-128-160-192

**W** 120-135-150-180 **Ht** 32 **Dpt** 45

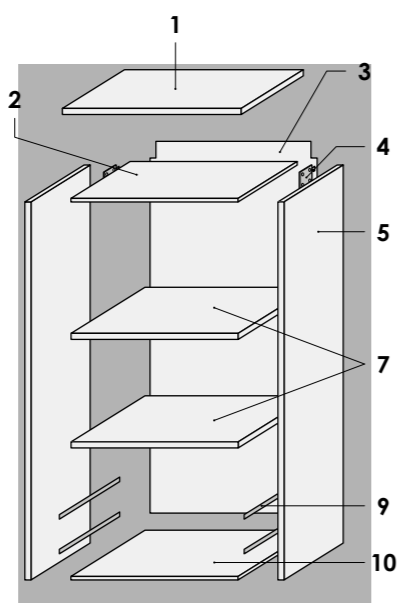

## Suspended Modular units

Dimensions (not including top):

**Dpt** 45-32,5

**W** 45-60 **Ht** 32-64-96

**W** 90 **Ht** 32-64

**W** 120-135-150\*-180\* **Ht** 32

**W** 30 **Ht** 96-128 **Dpt** 45

\* Dpt 45 only

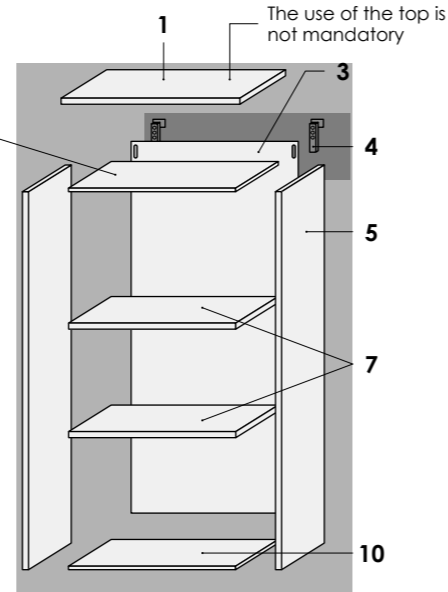

## Wall units

Dimensions (not including top):

**Dpt** 32,5

**W** 30 **Ht** 32-64-96-128

**W** 45-60 **Ht** 32-64-96

**W** 90 **Ht** 32-64

**W** 120 **Ht** 32

- Backs, shelves, top and bottom panels (the latter only in floor-standing modular units) in carcass colours.
- The side panels remain aligned with the top and bottom panel and have customized perforation.
- The hardware is placed in a personalized fashion according to the position of the components.
- The suspended Modular units and Wall units come with adjustable brackets with an antirelease device for wall fixing. The hardware in the wall units is invisible.
- You must complete every Floor/Support Modular units composition with top and bottom parts or with top and feet. A composition of multiple units can share same top and bottom. The use of the top is also recommended in the suspended Modular units while in the Wall units it is not mandatory.
- The modular elements and wall units W 120-135-150 consist of a single carcass with central divider Th 2.5, the deep drawers have a double interior with single front. The modular elements and wall units W 180 consist of 2 carcasses W 90 with single front.
- All Ht 16 - 32 - 64 elements, are provided already assembled (Ht 96 only Suspended modular units and Wall units).
- They comply with the European standard 14749 "Safety requirements for storage furniture for domestic use".

## IMPORTANT!

- The doors are fitted with decelerated hinges, with the exception of the folding doors which are equipped with concealed hinges.
- The ONE fronts (swing, pull-up, pull-down doors, drawers and deep drawers) can be equipped with push-pull opening. Selecting a "push-pull" handle will determine the need for "Quadro" type push-pull runners on the drawers.
- The drawers and big drawer CLUB and the big drawer W 120, 135, 150 and 180, are always fitted with height-adjustable soft-close "Quadro" metal slides with interior CHARM finish.
- **Internal fittings supplied with Modular units Dpt 56.3 consist in:** 1 clothes hanging bar in line with doors Ht 96 - 128 - 160 - 192; melamine-coated movable shelf every 32 cm in line with open compartments and where indicated with the dotted line.
- **Internal fittings supplied with Modular units Dpt 45, 32.5 and with Wall units consist in:** melamine-coated movable shelf every 32 cm.
- **For custom cuts consult the relevant chapter.**
- Upon request, the doors can be supplied without a handle and without handle holes (Not on CLUB and WINDOW).
- The Modular units and Wall units with pairs of CLUB doors are provided with only one handle. In elements with doors W 30 + W 60 the handle is placed on the W 60 door. Upon customer's request the CLUB handle can be mounted on both doors.
- In units W 90 with doors W 30 + W 60 the direction is determined by the position of the door W 60.

## Components:

- Top Th 1.4, 1.8, 2.5 or 5.5** (Th 5.5 only Dpt 45.6).
- Top panel Th 1.8** - With eccentric pin system
- Fibre back panel Th 0.3** - Fitting into shaped connection.
- Fixing hardware for suspension**
- Side panels Th 1.8** - With prefitted hardware.
- BASIC clothes hanging bar** in chromed metal **PLUS clothes hanging bar (optional)** in aluminium. (only for Dpt 56.3)
- Movable shelf Th 2.5** - On runner.
- Dividing movable shelf Th 2.5** - With sliding support. (only for Dpt 56.3)
- Metal drawer runners**
- Bottom panel Th 1.8** - With eccentric pin system  
The bottom panel can be fitted with:  
• ALFA-16 adjustable feet Ht 1.6  
• ALFA-25 adjustable feet Ht 2.5  
• DELTA adjustable feet Ht 11  
• NUME adjustable feet Ht 11  
• EPSILON adjustable feet Ht 15.5  
• TWIG adjustable feet Ht 16
- Bottom panel Th 1.8** - With eccentric pin system
- Base Ht 3 with 4 pads Ht 0.5**  
The base Th 2.5 can be fitted with:  
• DELTA adjustable feet Ht 11  
• NUME adjustable feet Ht 11  
• EPSILON adjustable feet Ht 15.5  
• TWIG adjustable feet Ht 16
- Base Ht 6.2 with 4 adjustable feet Ht 0.7** (Dpt 45.6 only).



## MODULAR COMPOSITION EXAMPLES

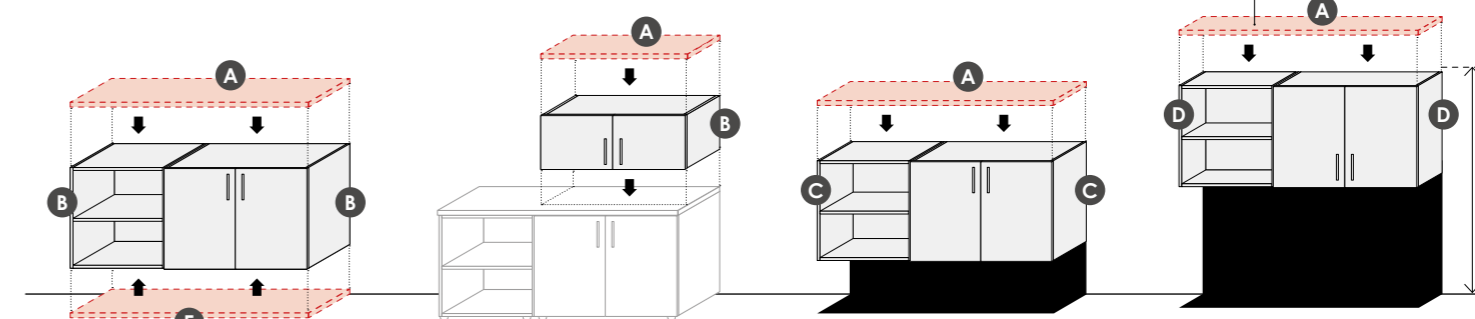

Example of composition with **Floor Modular units**

Example of composition with **Support Modular units**

Example of composition with **Suspended Modular units**

Example of composition with **Wall units**

- A** Top Th 1.4 / 1.8 / 2.5 / 5.5 (Th 5.5 only Dpt 45.6).
- B** Floor/support modular unit.
- C** Suspended modular unit.
- D** Wall unit.

- E Options:**
  - 1) ALFA-16, ALFA-25, DELTA, NUME, EPSILON and TWIG adjustable feet (without Base).
  - 2) Base Th 2.5 (With four pads H 0.5 plus the DELTA or NUME + one GAMMA-11 central feet, or EPSILON or TWIG + one GAMMA-15.5 central feet if required).
  - 3) Base Ht 6.2 (With four adjustable feet H 0.7) (Dpt 45.6 only).

**Example A:** Possible combinations of structures with the same depth. In the example, only tops to complete the composition are used.

**Example B:** Possible combinations of structures with the same depth. In the example, 1 top for completion and 2 intermediate tops between stacked structures are used.

**Example C:** Possible combinations of structures with the same depth. If, as in this example, only 1 intermediate top is used, there will be a difference in height between the L and R tall units equal to the thickness of the top. The solution is to use 2 intermediate tops, or none at all.

**Example D:** Possible combinations of structures with different depths. In the example, note the use of elements Dpt 56.3 in the lower part and of elements Dpt 45 and 32.5 in the upper part. It is best to use elements WITHOUT BOTTOM PANEL in the upper part and an intermediate top on top of the elements Dpt 56.3.

**Example E:** Possible combinations of structures with different heights. This composition is NOT FEASIBLE because there is a final difference in height between the R and L tall units, equal to the thickness of the intermediate top used above the elements Dpt 56.3.

**Example F:** Possible combinations of structures with the same height and different depths. In this example, note the use of elements with bottom panel. 2 with Dpt 56.3 at the ends and 2 with Dpt 32.5 in the middle. 2 bases Dpt 56.3 are used for the end elements and 1 base Dpt 32.5 for the middle elements. A single top Dpt 56.3 can be used.



## MODULAR UNITS + WARDROBES/CONTAINER UNITS

In the event that a Modular unit is placed side by side with a Wardrobe or a Container unit, it is recommended to use the Modular unit resting on the ALFA-16 foot in order to obtain the alignment of the fronts.

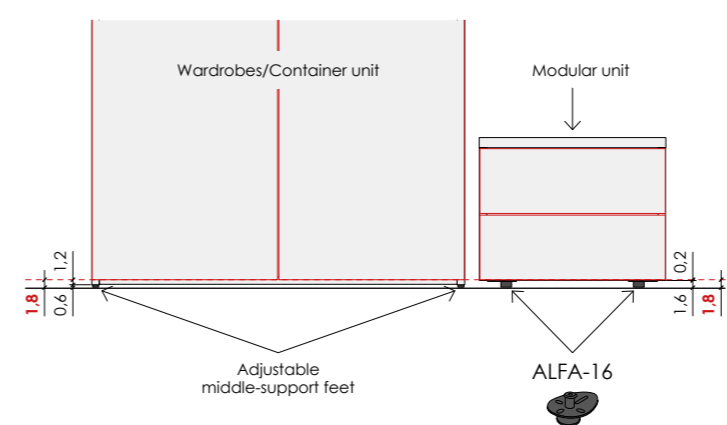

## INTERNAL LIGHTING

The lighting consists of: moveable melamine-faced shelves fitted with a led strip (60 LEDs per metre) positioned along the entire length of the shelf back, which lights both the lower and upper compartments by reflecting the light on the back panel, or by using led spotlights (this type of lighting is recommended in the cornice, cables are not concealed). A power supply unit is supplied (with a surcharge) for the shelves and spotlights that can power from 1 to 6 shelves 45/60-cm wide or 1 to 4 shelves, 90-cm wide. The type of lighting is natural. It can be switched on in 2 ways: by plugging it in and using the wall switch or by ordering a wireless switch from the price list.

# OPTIONAL for modular units and wall units

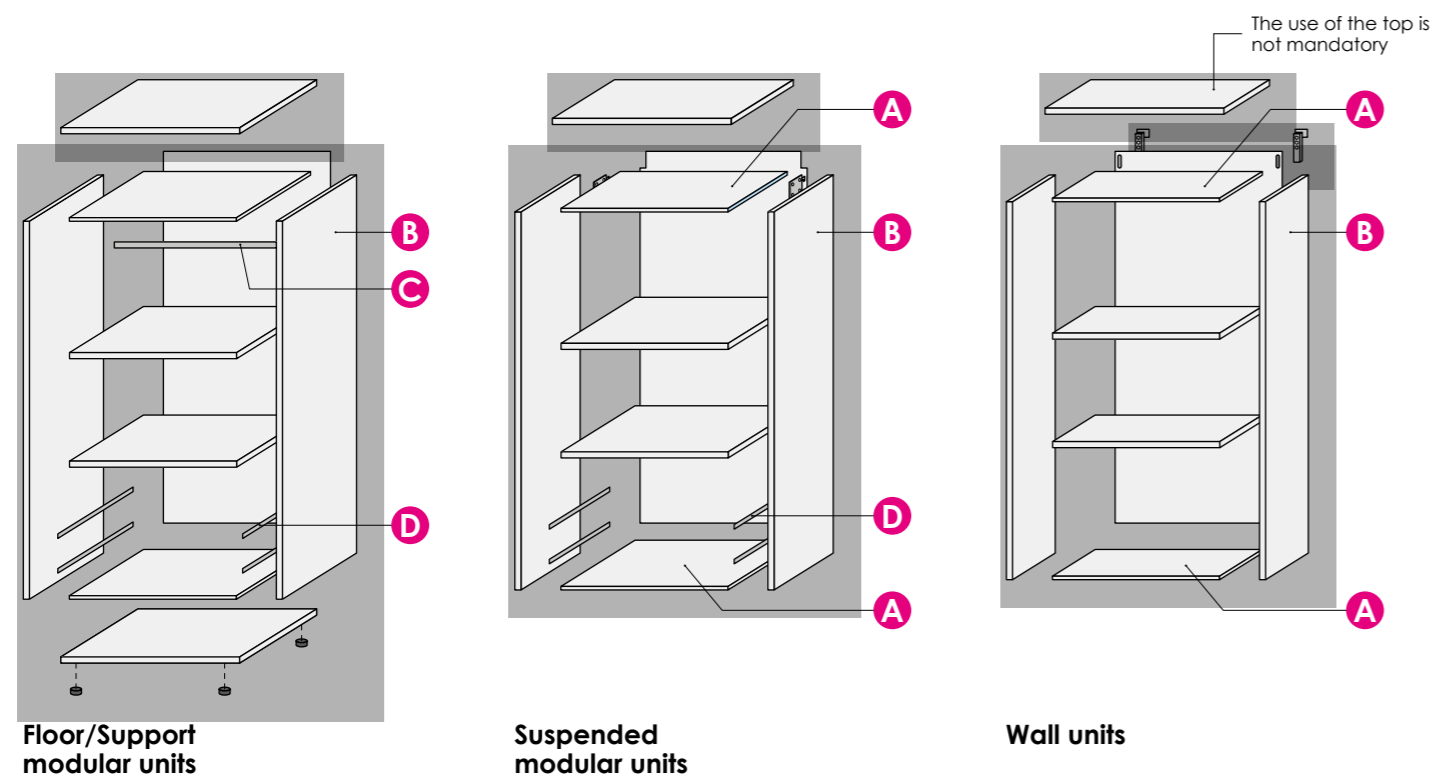

## A Extra colors for Top panel and Bottom panel (Suspended modulars units and Wall units)

In addition to the standard CARCASE colors, these components are all available in the GROUP 2 colors with surcharge (see table).

- **When placing the order:** indicate the colour in the TOP/BOTTOM variant in Metron 4; all top panels and bottom panels will automatically be delivered in that colour.
- **N.B.** In the ROUND desk, the color chosen for the TOP/BOTTOM will also determine the finish of the shelf.

Top panel Bottom panel	Surcharge for Dpt 45	Surcharge for Dpt 32.5
	(CARCASE colors excluded)	
W 30		
W 45		
W 60		
W 90		
W 120		
W 135		
W 150		
W 180		
ROUND desk W 90		

## B Extra colors for Side panels

In addition to the standard CARCASE colors, the side panels are available in all the GROUP 2 colors with surcharge (see table).

- **When placing the order:** indicate the colour in the COLOURED FINISHES variant in Metron 4; all side panels will automatically be delivered in that colour (if specified in the modular units Ht 128 - 160 - 192, 1, 2 or more side panels can be coloured as preferred).
- **N.B.** The surcharge is applied to each single side panel, except for the Modular units Ht 16 - 32 - 64 - 96, where the choice of colour refers to both side panels of the element.

Side panel	Surcharge for pair side panels Dpt 56.3 - 45	Surcharge for pair side panels Dpt 32.5
	(CARCASE colors excluded)	
Ht 16		
Ht 32		
Ht 64		
Ht 96		

Side panel	Surcharge for single panel Dpt 56.3 - 45	Surcharge for single panel Dpt 32.5
	(CARCASE colors excluded)	
Ht 128		
Ht 160		
Ht 192		

## C PLUS clothes-hanging bar

On request the Modular units Dpt 56.3 (Ht 96 - 128 - 160 - 192) can be equipped with PLUS clothes-hanging bars with surcharge (see table). The PLUS clothes-hanging bar is in aluminium Ø 2.8, available in the Alluminio (AL1A) and Grigio titanio (GZ8T) colors.

- **When placing the order:** indicate PLUS clothes-hanging bar in the BAR TYPE variant and the colour in the BAR COLOUR variant in Metron 4; all bars will automatically be delivered in the same type and same colour.



Clothes-hanging bars	Surcharge for single element
W 45	
W 60	
W 90	

## D Drawers and big drawers with soft-close

On request drawers and big drawers in the "standard" version can be equipped with soft-close mechanisms, with surcharge (see table). Alternatively, drawers and big drawers can be ordered in the CHARM version, with surcharge (see table), equipped with soft-close or push pull (not on CLUB drawers) height-adjustable "Quadro" type runners with prestigious internal finish.

- **When placing the order:** indicate the type of runners in the RUNNER TYPE variant in Metron 4.
- **N.B.** the CLUB drawers and big drawers and the big drawers W 120 - 135 - 150 - 180 are with soft-close "Quadro" type runners and are supplied standard in the CHARM version (without surcharge).

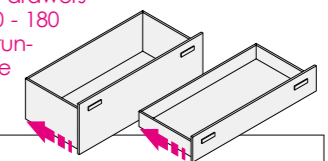

Slow closing	Surcharge for single element
Drawers W 45 - 60 - 90	
Big drawers W 45 - 60 - 90	
CHARM Drawers/Big drawers with soft-close "Quadro" type runners W 45 - 60 - 90	
CHARM Drawers/Big drawers with push pull "Quadro" type runners W 45 - 60 - 90	
CHARM Big drawers with push pull "Quadro" type runners W 120 - 135 - 150 - 180	

# Floor/support Modular units Dpt 56.3



Complete every composition with Top and Base or Top and Feet.

	Ht 16							Ht 32							Ht 64						
<b>W 45</b> Specify hinge R or L	Reference images →																				
	<b>Code</b>	P22.22V	P22.23A	P18.01Y	P18.00T	PK70.00E	P18.03K	P22.18Y	-	P18.08M	P18.09S	P18.11C	PL70.41L	P18.10X	P18.15Z	P18.33X	P18.17L	P18.47Y	PL70.12A		
	ONE	matte																			
	glossy																				
CLUB																					
WINDOW																					
<b>W 60</b> Specify hinge R or L	<b>Code</b>	P67.00A	P22.26S	P67.01F	P67.02M	PK70.01M	P22.01F	P67.03S	PL70.00G	P67.04X	P67.05C	P67.07P	PL70.42S	P67.06H	P67.09Z	P67.10E	P22.03S	P22.02M	PL70.15V		
	ONE	matte																			
		glossy																			
	CLUB																				
WINDOW																					
<b>W 90</b>	Reference images →																				
	<b>Code</b>	P22.24F	P22.25M	P18.05V	P18.04Q	PK70.02T	P18.07F	P22.19D		PL70.02V	P18.20B	P18.19W	P18.21G	PL70.43Y	P18.22N	P18.25D	P18.34C	P18.27Q	P18.60U	PL70.18Q	
	ONE	matte																			
	glossy																				
CLUB																					
WINDOW																					

- Components in **CARCASE** colors
- Components in **GROUP 2** colors
- Components in **Types and colors FRONT**

- With doors **W 30**
- With doors **W 30 + W 60** - Indicate R or L (drawing - R)



- p. 56** Knob and handle positions
- p. 662** Tops and Bases for Modular units and Wall units
- p. 666** Adjustable feet for Modular units
- p. 668** Accessories for Modular units and Wall units

**CLUB**  
drawers and big drawers  
CHARM with soft-close "Quadro"  
type slides as standard  
(without surcharges)

# Floor/support Modular units Dpt 56.3



Complete every composition with Top and Base or Top and Feet.

		Ht 64						Ht 96													
<b>W 45</b> Specify hinge R or L	Reference images →																				
	Code	PL70.13G	PL70.14P	-	P18.28V	P18.29A	P18.31M	PL70.04H		PL70.38A	P18.32S	P18.30F	P18.39E	P18.71D	PL70.21Z	PL70.22F	PL70.23N	P18.41R	-	-	
	ONE	matte																			
	CLUB																				
	WINDOW																				
<b>W 60</b> Specify hinge R or L	Code	PL70.16B	PL70.17H	PL70.01P	P67.11L	P67.12R	P67.15G	PL70.06W		PL70.39G	P67.13W	P67.14B	P67.18Y	P22.05C	PL70.24U	PL70.25A	PL70.26G	P67.19D	PL70.30Y	PL70.07C	
	ONE	matte																			
	CLUB																				
	WINDOW																				
<b>W 90</b>	Reference images →																				
	Code	PL70.19W	PL70.20T	PL70.03B	P18.46T	P18.49K	P18.51V	PL70.09R		PL70.40D	P18.52A	P18.50Q	P18.55S	P18.88W	PL70.27P	PL70.28V	PL70.29B	P18.57C	PL70.31E	PL70.10N	
	ONE	matte																			
	CLUB																				
	WINDOW																				

- Components in **CARCASE** colors
- Components in **GROUP 2** colors
- Components in **Types and colors FRONT**
- Element fitted with clothes hanging bar

- With doors **W 30**
- With doors **W 30 + W 60** - Indicate R or L (drawing - R)



**OPTIONAL:**  
p. 614

- B** · Extra colors for **SIDE PANELS**
- C** · **PLUS** clothes-hanging bar
- D** · Drawers and big drawers with soft-close



p. 56 Knob and handle positions  
 p. 662 Tops and Bases for Modular units and Wall units  
 p. 666 Adjustable feet for Modular units  
 p. 668 Accessories for Modular units and Wall units

**CLUB**  
 drawers and big drawers  
 CHARM with soft-close "Quadro"  
 type slides as standard  
 (without surcharges)

# Floor/support Modular units Dpt 56.3



Complete every composition with Top and Base or Top and Feet.

		Ht 128														Ht 160				
<b>W 45</b> Specify hinge R or L	Reference images →																			
	Code	P18.58H	P18.61Z	P18.66B	PL70.44E	PL70.45M	P18.12H	P18.62E		P18.14U	P18.18R	P18.76F	P18.73Q	P18.70Y	P18.74V	P18.77M	-	P17.58E	P70.01L	P70.06N
	ONE	matte																		
		glossy																		
	CLUB																			
	WINDOW																			
<b>W 60</b> Specify hinge R or L	Code	P67.21Q	P67.22V	P67.28C	PL70.46T	PL70.47Z	P67.23A	P67.26S		P67.24F	P67.30P	P67.36W	P22.07P	P67.31U	P67.34L	P67.37B	PL70.32M	P67.39N	P67.40T	P67.45V
	ONE	matte																		
		glossy																		
	CLUB																			
	WINDOW																			
<b>W 90</b>	Reference images →																			
	Code	P18.98A	P18.79X	P18.82P	PL70.48F	PL70.49N	P18.38Z	P18.80C		P18.40L	P18.48D	P18.26K	P18.99F	P18.84Z	P18.86L	P18.89B	PL70.33T	P17.98X	P70.22Z	P70.27B
	ONE	matte																		
		glossy																		
	CLUB																			
	WINDOW																			

- Components in **CARCASE** colors
- Components in **GROUP 2** colors
- Components in **Types and colors FRONT**
- Element fitted with clothes hanging bar
- With doors W 30
- With doors W 30 + W 60 - Indicate R or L (drawing - R)

**CLUB**  
drawers and big drawers  
CHARM with soft-close "Quadro"  
type slides as standard  
(without surcharges)

# Floor/support Modular units Dpt 56.3



Complete every composition with Top and Base or Top and Feet.

		Ht 160							Ht 192												
<b>W 45</b> Specify hinge R or L	Reference images →																				
	<b>Code</b>	<b>PL70.50K</b>	<b>PL70.53D</b>	<b>P70.02R</b>	<b>P70.05G</b>	<b>P70.08Y</b>	<b>P70.03W</b>	<b>P70.04B</b>		<b>P70.11Q</b>	<b>P70.16S</b>	<b>P70.07T</b>	<b>P70.13A</b>	<b>P70.19H</b>	<b>-</b>	<b>P17.70V</b>	<b>P70.43P</b>	<b>P70.48R</b>	<b>PL70.56Y</b>	<b>PL70.57E</b>	
	ONE	matte																			
		glossy																			
	CLUB																				
	WINDOW																				
<b>W 60</b> Specify hinge R or L	<b>Code</b>	<b>PL70.51R</b>	<b>PL70.54L</b>	<b>P67.41Y</b>	<b>P67.44Q</b>	<b>P67.47F</b>	<b>P67.42D</b>	<b>P67.43K</b>		<b>P67.50X</b>	<b>P67.55Z</b>	<b>P67.46A</b>	<b>P67.52H</b>	<b>P67.57L</b>	<b>PL70.34Z</b>	<b>P67.60B</b>	<b>P67.61G</b>	<b>P67.66K</b>	<b>PL70.59T</b>	<b>PL70.60Q</b>	
	ONE	matte																			
		glossy																			
	CLUB																				
	WINDOW																				
<b>W 90</b>	Reference images →																				
	<b>Code</b>	<b>PL70.52X</b>	<b>PL70.55S</b>	<b>P70.23E</b>	<b>P70.26W</b>	<b>P70.29N</b>	<b>P70.24L</b>	<b>P70.25R</b>		<b>P70.32D</b>	<b>P70.37F</b>	<b>P70.28G</b>	<b>P70.34Q</b>	<b>P70.40X</b>	<b>PL70.35F</b>	<b>P17.96M</b>	<b>P70.66P</b>	<b>P70.71R</b>	<b>PL70.62C</b>	<b>PL70.63K</b>	
	ONE	matte																			
		glossy																			
	CLUB																				
	WINDOW																				

- Components in **CARCASE** colors
- Components in **GROUP 2** colors
- Components in **Types and colors FRONT**
- Element fitted with clothes hanging bar
- With doors **W 30**
- With doors **W 30 + W 60** - Indicate R or L (drawing - R)

- p. 56** Knob and handle positions
- p. 662** Tops and Bases for Modular units and Wall units
- p. 666** Adjustable feet for Modular units
- p. 668** Accessories for Modular units and Wall units

**CLUB**  
drawers and big drawers  
CHARM with soft-close "Quadro"  
type slides as standard  
(without surcharges)



# Floor/support Modular units Dpt 56.3

Complete every composition with Top and Base or Top and Feet.

**W 45**  
Specify hinge R or L

Reference images →

Hi 192

<b>Code</b>	<b>PL70.58M</b>	<b>P70.44U</b>	<b>P70.47L</b>	<b>P70.52N</b>	<b>P70.45Z</b>	<b>P70.46E</b>	<b>P70.55D</b>		<b>P70.61M</b>	<b>P70.50B</b>	<b>P70.57Q</b>	<b>P70.63X</b>	-					
ONE	matte																	
	glossy																	
CLUB																		
WINDOW																		

**W 60**  
Specify hinge R or L

<b>Code</b>	<b>PL70.61W</b>	<b>P67.62N</b>	<b>P67.65D</b>	<b>P67.70F</b>	<b>P67.63T</b>	<b>P67.64Y</b>	<b>P67.73X</b>		<b>P67.78Z</b>	<b>P67.68V</b>	<b>P67.75H</b>	<b>P67.80L</b>	<b>PL70.36N</b>					
ONE	matte																	
	glossy																	
CLUB																		
WINDOW																		

**W 90**

Reference images →

<b>Code</b>	<b>PL70.64R</b>	<b>P70.67U</b>	<b>P70.70L</b>	<b>P70.75N</b>	<b>P70.68Z</b>	<b>P70.69E</b>	<b>P70.78D</b>		<b>P70.84M</b>	<b>P70.73B</b>	<b>P70.80Q</b>	<b>P70.86X</b>	<b>PL70.37U</b>					
ONE	matte																	
	glossy																	
CLUB																		
WINDOW																		

- Components in **CARCASE** colors
- Components in **GROUP 2** colors
- Components in **Types and colors FRONT**
- Element fitted with clothes hanging bar

- With doors **W 30**
- With doors **W 30 + W 60** - Indicate R or L (drawing - R)

**OPTIONAL:** **p. 614**

- B** · Extra colors for **SIDE PANELS**
- C** · **PLUS** clothes-hanging bar
- D** · Drawers and big drawers with soft-close

- p. 56** Knob and handle positions
- p. 662** Tops and Bases for Modular units and Wall units
- p. 666** Adjustable feet for Modular units
- p. 668** Accessories for Modular units and Wall units

**CLUB**  
drawers and big drawers  
CHARM with soft-close "Quadro"  
type slides as standard  
(without surcharges)

# L corner Modular units Dpt 56.3 - W 90

# R corner Modular units Dpt 56.3 - W 90

	Ht 32	Ht 64	Ht 96	Ht 128	Ht 160	Ht 192
<b>Code</b>	<b>P57.02K</b>	<b>P57.01D</b>	<b>P57.03Q</b>	<b>P57.05A</b>	<b>P57.04V</b>	<b>P57.06F</b>
ONE	matte					
	glossy					
CLUB						

	Ht 32	Ht 64	Ht 96	Ht 128	Ht 160	Ht 192
<b>Code</b>	<b>P57.08S</b>	<b>P57.07M</b>	<b>P57.09X</b>	<b>P57.11H</b>	<b>P57.10C</b>	<b>P57.12P</b>
ONE	matte					
	glossy					
CLUB						

## L corner Tops Dpt 56.9

	W 104.9	W 149.9	W 164.9	W 194.9	customised W Min 61 Max 300 (matte) Max 258 (glossy)
<b>Tops Th 1.8</b>	<b>PK70.10L</b>	<b>PK70.11S</b>	<b>PK70.12Y</b>	<b>PK70.13E</b>	<b>PK70.14M</b>
matte					
glossy					

## R corner Tops Dpt 56.9

	W 104.9	W 149.9	W 164.9	W 194.9	customised W Min 61 Max 300 (matte) Max 258 (glossy)
<b>Tops Th 1.8</b>	<b>PK70.20R</b>	<b>PK70.21X</b>	<b>PK70.22D</b>	<b>PK70.23L</b>	<b>PK70.24S</b>
matte					
glossy					

## L corner Countertops Dpt 56.9

	W 48	W 63	W 93	customised W Min 30 Max 300 (matte) Max 258 (glossy)
<b>Tops Th 1.8</b>	<b>PK70.15T</b>	<b>PK70.16Z</b>	<b>PK70.17F</b>	<b>PK70.18N</b>
matte				
glossy				

## R corner Countertops Dpt 56.9

	W 48	W 63	W 93	customised W Min 30 Max 300 (matte) Max 258 (glossy)
<b>Tops Th 1.8</b>	<b>PK70.25Y</b>	<b>PK70.26E</b>	<b>PK70.27M</b>	<b>PK70.28T</b>
matte				
glossy				

## L corner Tops and Bases Dpt 57.1

	W 104.9	W 149.9	W 164.9	W 194.9	customised W Min 61 Max 360
<b>Tops Th 2.5</b>	<b>PL68.01V</b>	<b>PL68.02B</b>	<b>PL68.03H</b>	<b>PL68.04Q</b>	<b>PL68.05W</b>
<b>Bases Ht 3</b>	<b>PL68.11A</b>	<b>PL68.12G</b>	<b>PL68.13P</b>	<b>PL68.14V</b>	<b>PL68.15B</b>

## R corner Tops and Bases Dpt 57.1

	W 104.9	W 149.9	W 164.9	W 194.9	customised W Min 61 Max 360
<b>Tops Th 2.5</b>	<b>PL68.06C</b>	<b>PL68.07K</b>	<b>PL68.08R</b>	<b>PL68.09X</b>	<b>PL68.10U</b>
<b>Bases Ht 3</b>	<b>PL68.16H</b>	<b>PL68.17Q</b>	<b>PL68.18W</b>	<b>PL68.19C</b>	<b>PL68.20Z</b>

## L corner Countertops and Counterbases Dpt 57.1

	W 47.8	W 62.8	W 92.8	customised W Min 2.8 Max 360
<b>Tops Th 2.5</b>	<b>PL68.21F</b>	<b>PL68.22N</b>	<b>PL68.23U</b>	<b>PL68.24A</b>
<b>Bases Ht 3</b>	<b>PL68.31M</b>	<b>PL68.32T</b>	<b>PL68.33Z</b>	<b>PL68.34F</b>

## R corner Countertops and Counterbases Dpt 57.1

	W 47.8	W 62.8	W 92.8	customised W Min 2.8 Max 360
<b>Tops Th 2.5</b>	<b>PL68.26P</b>	<b>PL68.27V</b>	<b>PL68.28B</b>	<b>PL68.29H</b>
<b>Bases Ht 3</b>	<b>PL68.36U</b>	<b>PL68.37A</b>	<b>PL68.38G</b>	<b>PL68.39P</b>

- Components in **CARCASE** colors
- Components in **GROUP 1** colors
- Components in **GROUP 2** colors
- Components in **Types and colors FRONT**
- When using this element it is essential to send a drawing
- Element fitted with clothes hanging bar

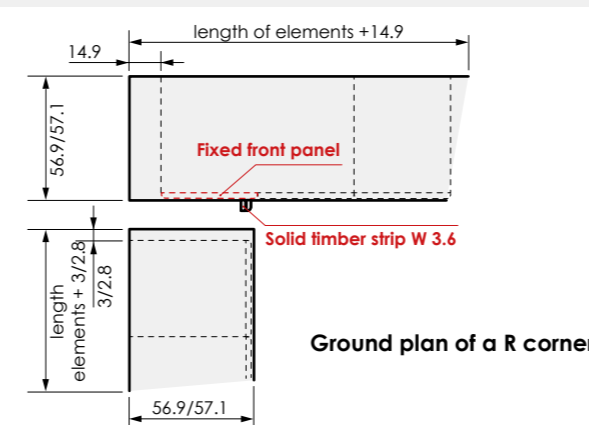
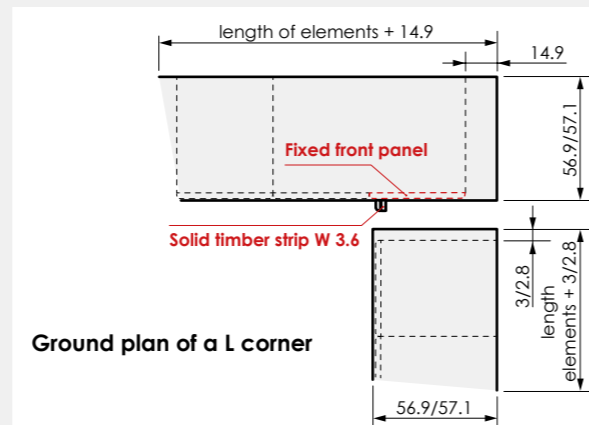

**OPTIONAL:** B - Extra colors for SIDE PANELS  
p. 614 C - PLUS clothes-hanging bar

p. 56 Knob and handle positions  
p. 666 Adjustable feet for Modular units  
p. 668 Accessories for Modular units and Wall units

# Floor/support Modular units Dpt 45

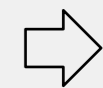

Complete every composition with Top and Base or Top and Feet.

	Ht 16		Ht 32					Ht 64												
<b>W 45</b> Specify hinge R or L	Reference images →																			
	Code	P55.78R	P55.79W	P20.01Z	P20.00U	PK70.30W	P20.03L	P22.20K			P20.08N	P20.09T	P20.11D	PL72.46B	P20.10Y	P20.15A	P20.33Y	P20.17M	PL72.00R	PL72.09Z
	ONE	matte																		
	glossy																			
CLUB																				
WINDOW																				

<b>W 60</b> Specify hinge R or L	Code	P55.80B	P55.81G	P69.00G	P69.01N	PK70.31C	P22.11L	P69.02T		PL72.01X	P69.03Y	P69.04D	P69.06Q	PL72.47H	P69.05K	P69.08A	P69.09F	P22.13W	PL72.02D	PL72.12K
	ONE	matte																		
		glossy																		
	CLUB																			
WINDOW																				

	Reference images →																			
<b>W 90</b>																				
	Code	P55.82N	P55.83T	P20.05W	P20.04R	PK70.32K	P20.07G	P22.21Q		PL72.04S	P20.20C	P20.19X	P20.21H	PL72.48Q	P20.22P	P20.25E	P20.34D	P20.27R	PL72.05Y	PL72.15D
	ONE	matte																		
		glossy																		
CLUB																				
WINDOW																				

## W 120 - 135 - 150 - 180

Big drawers CHARM with "Quadro" type soft rails as standard (without surcharges)

	Reference images →																		
	Code			PK70.97Z	PK70.98F	PK70.34X			PK70.35D	PK70.36L	PK70.37S	PK70.38Y	PK70.39E						
	ONE	matte																	
		glossy																	
CLUB																			
WINDOW																			

- Components in **CARCASE** colors
- Components in **GROUP 2** colors
- Components in **Types and colors FRONT**

- With doors **W 30**
- With doors **W 30 + W 60** - Indicate R or L (drawing - R)



**OPTIONAL:** p. 614 **B** - Extra colors for **SIDE PANELS**  
**D** - Drawers and big drawers with soft-close

**CLUB**  
drawers and big drawers CHARM with soft-close "Quadro" type slides as standard (without surcharges)



- p. 56 Knob and handle positions
- p. 662 Tops and Bases for Modular units and Wall units
- p. 666 Adjustable feet for Modular units
- p. 668 Accessories for Modular units and Wall units

# Floor/support Modular units Dpt 45



Complete every composition with Top and Base or Top and Feet.

	Ht 64			Ht 96															Ht 128		
<b>W 45</b> Specify hinge R or L	Reference images →																				
	<b>Code</b>	PL72.10W	PL72.11C	-	P20.28W	P20.29B	P99.51R	P20.31N		PL72.41U	P20.32T	P20.30G	P20.39F	P20.70Z	PL72.18Y	PL72.19E	PL72.20B	P20.41S	-	P20.58K	
	ONE	matte																			
	glossy																				
	CLUB																				
	WINDOW																				
<b>W 60</b> Specify hinge R or L	<b>Code</b>	PL72.13R	PL72.14X	PL72.03L	P69.10M	P69.11S	P69.85U	P69.14H		PL72.42A	P69.12X	P69.13C	P69.17Z	P22.15G	PL72.21H	PL72.22Q	PL72.23W	P69.18E	PL72.07M	P69.20R	
	ONE	matte																			
		glossy																			
	CLUB																				
	WINDOW																				
<b>W 90</b>	Reference images →																				
	<b>Code</b>	PL72.16L	PL72.17S	PL72.06E	P20.46U	P20.45P	P99.52W	P20.47Z		PL72.43G	P20.52B	P20.50R	P20.51W	P20.26L	PL72.24C	PL72.25K	PL72.26R	P20.53G	PL72.08T	P20.98B	
	ONE	matte																			
	glossy																				
	CLUB																				
	WINDOW																				

- Components in **CARCASE** colors
- Components in **GROUP 2** colors
- Components in **Types and colors FRONT**

- With doors W 30**
- With doors W 30 + W 60** - Indicate R or L (drawing - R)
- Without bottom panel.**

**OPTIONAL:** **p. 614** **B** - Extra colors for **SIDE PANELS**  
**D** - Drawers and big drawers with soft-close

- p. 56** Knob and handle positions
- p. 662** Tops and Bases for Modular units and Wall units
- p. 666** Adjustable feet for Modular units
- p. 668** Accessories for Modular units and Wall units

**CLUB**  
drawers and big drawers  
CHARM with soft-close "Quadro"  
type slides as standard  
(without surcharges)

# Floor/support Modular units Dpt 45



Complete every composition with Top and Base or Top and Feet.

	Ht 128														Ht 160					
<b>W 45</b> Specify hinge R or L	Reference images →																			
	Code	P20.61A	P99.25Z	P20.67H	PL72.49W	PL72.50T	P20.12K	P20.63M		P20.14V	P20.18S	P20.76G	P20.72L	P20.71E	P20.74W	P20.77N	-	P22.58R	P72.01S	P99.26E
	ONE	matte																		
	CLUB																			
W 60																				
Code	P69.21W	P69.86Z	P69.27D	PL72.51Z	PL72.52F	P69.22B	P69.25T		P69.23G	P69.29Q	P69.35X	P22.17T	P69.30V	P69.33M	P69.36C	PL72.27X	P69.38P	P69.39U	P69.95Y	
ONE	matte																			
CLUB																				
W 90																				
Reference images →																				
Code	P20.80D	P99.28R	P20.83V	PL72.53N	PL72.54U	P20.99G	P20.81K		P20.40M	P20.48E	P20.89C	P20.95L	P20.85F	P20.87S	P20.90H	PL72.28D	P22.98H	P72.22F	P99.29W	
ONE	matte																			
CLUB																				

- Components in **CARCASE** colors
- Components in **GROUP 2** colors
- Components in **Types and colors FRONT**

- With doors W 30**
- With doors W 30 + W 60** - Indicate R or L (drawing - R)
- Without bottom panel.

**OPTIONAL:** **p. 614** **B** - Extra colors for **SIDE PANELS**  
**D** - Drawers and big drawers with soft-close

- p. 56** Knob and handle positions
- p. 662** Tops and Bases for Modular units and Wall units
- p. 666** Adjustable feet for Modular units
- p. 668** Accessories for Modular units and Wall units

**CLUB**  
drawers and big drawers  
CHARM with soft-close "Quadro"  
type slides as standard  
(without surcharges)

# Floor/support Modular units Dpt 45



Complete every composition with Top and Base or Top and Feet.

		Ht 160														Ht 192			
<b>W 45</b> Specify hinge R or L	Reference images →																		
	Code	P72.06U	PL72.55A	PL72.56G	P72.02X	PL72.57P	P72.05P	P72.08E	P72.03C	P72.04H	P72.11W	P72.16Y	P72.07Z	P72.13G	P72.19Q	-	P22.70F	P72.43V	P99.27L
	ONE	matte																	
	CLUB	glossy																	
W 60	Code	P69.44W	PL72.58V	PL72.59B	P69.40Z	PL72.60Y	P69.43R	P69.46G	P69.41E	P69.42L	P69.49Y	P69.54A	P69.45B	P69.51K	P69.56M	PL72.29L	P69.60H	P69.61P	P73.58E
W 90	Reference images →																		
Code	P72.27H	PL72.61E	PL72.62M	P72.23M	PL72.63T	P72.26C	P72.29U	P72.24S	P72.25X	P72.32L	P72.37N	P72.28P	P72.34W	P72.40D	PL72.30G	P22.96X	P72.66V	P99.30B	
ONE	matte																		
CLUB	glossy																		
W 90	Code	P72.27H	PL72.61E	PL72.62M	P72.23M	PL72.63T	P72.26C	P72.29U	P72.24S	P72.25X	P72.32L	P72.37N	P72.28P	P72.34W	P72.40D	PL72.30G	P22.96X	P72.66V	P99.30B
ONE	matte																		
CLUB	glossy																		
W 90	Code	P72.27H	PL72.61E	PL72.62M	P72.23M	PL72.63T	P72.26C	P72.29U	P72.24S	P72.25X	P72.32L	P72.37N	P72.28P	P72.34W	P72.40D	PL72.30G	P22.96X	P72.66V	P99.30B
ONE	matte																		
CLUB	glossy																		
W 90	Code	P72.27H	PL72.61E	PL72.62M	P72.23M	PL72.63T	P72.26C	P72.29U	P72.24S	P72.25X	P72.32L	P72.37N	P72.28P	P72.34W	P72.40D	PL72.30G	P22.96X	P72.66V	P99.30B
ONE	matte																		
CLUB	glossy																		
W 90	Code	P72.27H	PL72.61E	PL72.62M	P72.23M	PL72.63T	P72.26C	P72.29U	P72.24S	P72.25X	P72.32L	P72.37N	P72.28P	P72.34W	P72.40D	PL72.30G	P22.96X	P72.66V	P99.30B
ONE	matte																		
CLUB	glossy																		
W 90	Code	P72.27H	PL72.61E	PL72.62M	P72.23M	PL72.63T	P72.26C	P72.29U	P72.24S	P72.25X	P72.32L	P72.37N	P72.28P	P72.34W	P72.40D	PL72.30G	P22.96X	P72.66V	P99.30B
ONE	matte																		
CLUB	glossy																		

- Components in **CARCASE** colors
- Components in **GROUP 2** colors
- Components in **Types and colors FRONT**

- With doors W 30**
- With doors W 30 + W 60** - Indicate R or L (drawing - R)
- Without bottom panel.**



**OPTIONAL:** **p. 614** **B** - Extra colors for **SIDE PANELS**  
**D** - Drawers and big drawers with soft-close



**p. 56** Knob and handle positions  
**p. 662** Tops and Bases for Modular units and Wall units  
**p. 666** Adjustable feet for Modular units  
**p. 668** Accessories for Modular units and Wall units

**CLUB**  
drawers and big drawers  
CHARM with soft-close "Quadro"  
type slides as standard  
(without surcharges)



# Floor/support Modular units Dpt 45

Complete every composition with Top and Base or Top and Feet.

**W 45**  
Specify hinge R or L

Reference images →

Ht 192

Code	P72.48X	PL72.64Z	PL72.65F	PL72.66N	PL72.67U	P72.44A	P72.47S		P72.52U	P72.45F	P72.46M	P72.55L	PL72.68A	P72.50H	P72.57W	P72.63D	-		
ONE	matte																		
	glossy																		
CLUB																			
WINDOW																			



**W 60**  
Specify hinge R or L

Code	P69.66R	PL72.69G	PL72.70D	PL72.71L	PL72.72S	P69.62U	P69.65L		P69.70N	P69.63Z	P69.64E	P69.73D	PL72.73Y	P69.68B	P69.75Q	P69.80S	PL72.31P		
ONE	matte																		
	glossy																		
CLUB																			
WINDOW																			

**W 90**

Reference images →

Code	P72.71X	PL72.74E	PL72.75M	PL72.76T	PL72.77Z	P72.67A	P72.70S		P72.75U	P72.68F	P72.69M	P72.78L	PL72.78F	P72.73H	P72.80W	P72.86D	PL72.32V		
ONE	matte																		
	glossy																		
CLUB																			
WINDOW																			

-  Components in **CARCASE** colors
-  Components in **GROUP 2** colors
-  Components in **Types and colors FRONT**

-  With doors **W 30**
-  With doors **W 30 + W 60** - Indicate R or L (drawing - R)

 **OPTIONAL:** **p. 614** **B** - Extra colors for **SIDE PANELS**  
**D** - Drawers and big drawers with soft-close

-  **p. 56** Knob and handle positions
- p. 662** Tops and Bases for Modular units and Wall units
- p. 666** Adjustable feet for Modular units
- p. 668** Accessories for Modular units and Wall units

**CLUB**  
drawers and big drawers  
CHARM with soft-close "Quadro"  
type slides as standard  
(without surcharges)

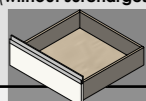

# L corner Modular units Dpt 45 - W 90

# R corner Modular units Dpt 45 - W 90

	Ht 32	Ht 64	Ht 96	Ht 128	Ht 160	Ht 192
<b>Code</b>	<b>P56.02F</b>	<b>P56.01A</b>	<b>P56.03M</b>	<b>P56.05X</b>	<b>P56.04S</b>	<b>P56.06C</b>
ONE	matte					
	glossy					
CLUB						

	Ht 32	Ht 64	Ht 96	Ht 128	Ht 160	Ht 192
<b>Code</b>	<b>P56.08P</b>	<b>P56.07H</b>	<b>P56.09U</b>	<b>P56.11E</b>	<b>P56.10Z</b>	<b>P56.12L</b>
ONE	matte					
	glossy					
CLUB						

## L corner Tops Dpt 45.6

	W 93.6	W 138.6	W 153.6	W 183.6	customised W Min 61 Max 300 (matte) Max 258 (glossy)
<b>Tops Th 1.8</b>	<b>PK70.40B</b>	<b>PK70.41H</b>	<b>PK70.42Q</b>	<b>PK70.43W</b>	<b>PK70.44C</b>
matte					
glossy					

## R corner Tops Dpt 45.6

	W 93.6	W 138.6	W 153.6	W 183.6	customised W Min 61 Max 300 (matte) Max 258 (glossy)
<b>Tops Th 1.8</b>	<b>PK70.50G</b>	<b>PK70.51P</b>	<b>PK70.52V</b>	<b>PK70.53B</b>	<b>PK70.54H</b>
matte					
glossy					

## L corner Countertops Dpt 45.6

	W 48	W 63	W 93	customised W Min 30 Max 300 (matte) Max 258 (glossy)
<b>Tops Th 1.8</b>	<b>PK70.45K</b>	<b>PK70.46R</b>	<b>PK70.47X</b>	<b>PK70.48D</b>
matte				
glossy				

## R corner Countertops Dpt 45.6

	W 48	W 63	W 93	customised W Min 30 Max 300 (matte) Max 258 (glossy)
<b>Tops Th 1.8</b>	<b>PK70.55Q</b>	<b>PK70.56W</b>	<b>PK70.57C</b>	<b>PK70.58K</b>
matte				
glossy				

## L corner Tops and Bases Dpt 45.8

	W 93.6	W 138.6	W 153.6	W 183.6	customised W Min 61 Max 360
<b>Tops Th 2.5</b>	<b>PL68.51X</b>	<b>PL68.52D</b>	<b>PL68.53L</b>	<b>PL68.54S</b>	<b>PL68.55Y</b>
<b>Bases Ht 3</b>	<b>PL68.61C</b>	<b>PL68.62K</b>	<b>PL68.63R</b>	<b>PL68.64X</b>	<b>PL68.65D</b>

## R corner Tops and Bases Dpt 45.8

	W 93.6	W 138.6	W 153.6	W 183.6	customised W Min 61 Max 360
<b>Tops Th 2.5</b>	<b>PL68.56E</b>	<b>PL68.57M</b>	<b>PL68.58T</b>	<b>PL68.59Z</b>	<b>PL68.60W</b>
<b>Bases Ht 3</b>	<b>PL68.66L</b>	<b>PL68.67S</b>	<b>PL68.68Y</b>	<b>PL68.69E</b>	<b>PL68.70B</b>

## L corner Countertops and Counterbases Dpt 45.8

	W 47.8	W 62.8	W 92.8	customised W Min 2.8 Max 360
<b>Tops Th 2.5</b>	<b>PL68.71H</b>	<b>PL68.72Q</b>	<b>PL68.73W</b>	<b>PL68.74C</b>
<b>Bases Ht 3</b>	<b>PL68.81P</b>	<b>PL68.82V</b>	<b>PL68.83B</b>	<b>PL68.84H</b>

## R corner Countertops and Counterbases Dpt 45.8

	W 47.8	W 62.8	W 92.8	customised W Min 2.8 Max 360
<b>Tops Th 2.5</b>	<b>PL68.76R</b>	<b>PL68.77X</b>	<b>PL68.78D</b>	<b>PL68.79L</b>
<b>Bases Ht 3</b>	<b>PL68.86W</b>	<b>PL68.87C</b>	<b>PL68.88K</b>	<b>PL68.89R</b>

- Components in **CARCASE** colors
- Components in **GROUP 1** colors
- Components in **GROUP 2** colors
- Components in **Types and colors FRONT**
- When using this element it is essential to send a drawing

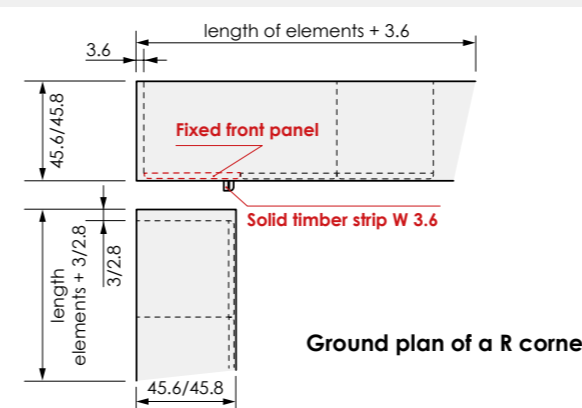
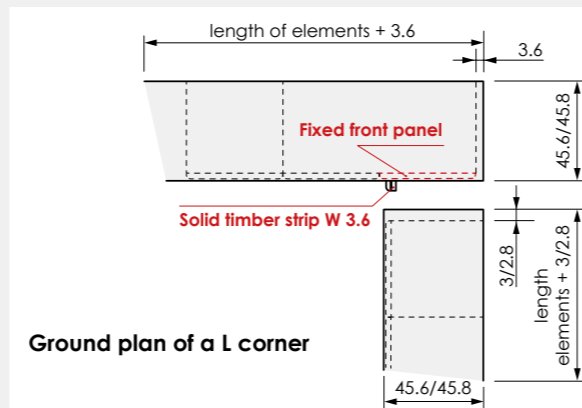

**OPTIONAL: B** - Extra colors for SIDE PANELS p. 614

p. 56 Knob and handle positions  
p. 666 Adjustable feet for Modular units  
p. 668 Accessories for Modular units and Wall units

# Floor/support Modular units Dpt 32.5



Complete every composition with Top and Base or Top and Feet.

		Ht 16		Ht 32					Ht 64											
<b>W 45</b> Specify hinge R or L	Reference images →																			
	Code	P54.04L	P54.05R	P19.04T	P19.06D	P19.43E	P96.86W	-		P19.02G	P19.01B	P19.03N	PL74.36E	P19.16H	P19.76K	P19.25G	P19.77Q	PL74.00Z	PL74.09H	PL74.10E
	ONE	matte																		
		glossy																		
	CLUB																			
	WINDOW																			
<b>W 60</b> Specify hinge R or L	Code	P54.06W	P54.07B	P54.12D	P54.13K	P54.14Q	P96.87B	PL74.01F		P54.15V	P54.16A	P54.22H	PL74.37M	P54.17F	P54.24U	P19.27T	P54.26E	PL74.02N	PL74.12T	PL74.13Z
	ONE	matte																		
		glossy																		
	CLUB																			
	WINDOW																			
<b>W 90</b>	Reference images →																			
	Code	P54.09N	P54.10T	P19.10A	P19.12M	P19.47B	P96.88G	PL74.04A		P19.08Q	P19.07K	P19.09V	PL74.38T	P19.22R	P19.78V	P19.28Y	P19.79A	PL74.05G	PL74.15N	PL74.16U
	ONE	matte																		
		glossy																		
	CLUB																			
	WINDOW																			

- Components in **CARCASE** colors
- Components in **GROUP 2** colors
- Components in **Types and colors FRONT**

- With doors **W 30**
- With doors **W 30 + W 60** - Indicate R or L (drawing - R)

- OPTIONAL:** **p. 614**
- B** - Extra colors for **SIDE PANELS**
- D** - Drawers and big drawers with soft-close

- p. 56** Knob and handle positions
- p. 662** Tops and Bases for Modular units and Wall units
- p. 666** Adjustable feet for Modular units
- p. 668** Accessories for Modular units and Wall units

**CLUB**  
drawers and big drawers  
CHARM with soft-close "Quadro"  
type slides as standard  
(without surcharges)

# Floor/support Modular units Dpt 32.5



Complete every composition with Top and Base or Top and Feet.

	Ht 64							Ht 96							Ht 128					
<b>W 45</b> Specify hinge R or L	Reference images →																			
	<b>Code</b>	PL74.11M	-	P19.14X	P19.13S	P99.49E	P19.19Z	PL74.33L		P19.26N	P19.72N	P19.80F	P19.15C	PL74.18G	PL74.19P	PL74.20L	P19.87U	-	P19.34F	P19.33A
	ONE	matte																		
	CLUB																			
WINDOW																				
<b>W 60</b> Specify hinge R or L	<b>Code</b>	PL74.14F	PL74.03U	P54.32N	P54.33T	P55.15Y	P54.36K	PL74.34S		P54.34Y	P54.35D	P54.40F	P54.44C	PL74.21S	PL74.22Y	PL74.23E	P54.42S	PL74.07V	P54.45H	P54.46P
	ONE	matte																		
	CLUB																			
	WINDOW																			
<b>W 90</b>	Reference images →																			
	<b>Code</b>	PL74.17A	PL74.06P	P19.24B	P19.23W	P99.50L	P19.29D	PL74.35Y		P19.36S	P19.75D	P19.89E	P19.17P	PL74.24M	PL74.25T	PL74.26Z	P19.90L	PL74.08B	P19.54Q	P19.53K
	ONE	matte																		
	CLUB																			
WINDOW																				

- Components in **CARCASE** colors
- Components in **GROUP 2** colors
- Components in **Types and colors FRONT**

- With doors **W 30**
- With doors **W 30 + W 60** - Indicate R or L (drawing - R)
- Without bottom panel.



**OPTIONAL:** **p. 614** **B** - Extra colors for **SIDE PANELS**  
**D** - Drawers and big drawers with soft-close



**p. 56** Knob and handle positions  
**p. 662** Tops and Bases for Modular units and Wall units  
**p. 666** Adjustable feet for Modular units  
**p. 668** Accessories for Modular units and Wall units

**CLUB**  
drawers and big drawers  
CHARM with soft-close "Quadro"  
type slides as standard  
(without surcharges)

# Floor/support Modular units Dpt 32.5



Complete every composition with Top and Base or Top and Feet.

	Ht 128														Ht 160				
<b>W 45</b> Specify hinge R or L	Reference images →																		
	<b>Code</b>	P99.43X	P19.49N	PL74.39Z	PL74.40W	P19.38C	P19.44L	P19.40P	P19.92W	P19.95N	P19.18U	P19.93B	PL74.41C	PL74.42K	-	P19.73T	P74.01Y	P99.44C	P74.11C
	ONE	matte																	
	CLUB																		
WINDOW																			
<b>W 60</b> Specify hinge R or L	<b>Code</b>	P55.16D	P54.54G	PL74.43R	PL74.44X	P54.47U	P54.52W	P54.49E	P54.56T	P54.62A	P54.64M	P54.57Y	PL74.45D	PL74.46L	PL74.27F	P54.65S	P54.66X	P55.27P	P54.72E
	ONE	matte																	
	CLUB																		
	WINDOW																		
<b>W 90</b>	Reference images →																		
	<b>Code</b>	P99.46P	P19.69W	PL74.47S	PL74.48Y	P19.50T	P19.58M	P19.52D	P19.98D	P74.03K	P19.20E	P19.99K	PL74.49E	PL74.50B	PL74.28N	P19.66E	P74.22N	P99.47U	P74.32S
	ONE	matte																	
	CLUB																		
WINDOW																			

- Components in **CARCASE** colors
- Components in **GROUP 2** colors
- Components in **Types and colors FRONT**

- With doors W 30**
- With doors W 30 + W 60** - Indicate R or L (drawing - R)
- Without bottom panel.**

**OPTIONAL:** **p. 614** **B** - Extra colors for **SIDE PANELS**  
**D** - Drawers and big drawers with soft-close

- p. 56** Knob and handle positions
- p. 662** Tops and Bases for Modular units and Wall units
- p. 666** Adjustable feet for Modular units
- p. 668** Accessories for Modular units and Wall units

**CLUB**  
drawers and big drawers  
CHARM with soft-close "Quadro"  
type slides as standard  
(without surcharges)

# Floor/support Modular units Dpt 32.5



Complete every composition with Top and Base or Top and Feet.

		Ht 160														Ht 192					
<b>W 45</b> Specify hinge R or L	Reference images →																				
	Code	PL74.51H	PL74.52Q	P74.02D	P74.05V	P74.14U	P74.08M	PL74.53W		P74.07F	PL74.54C	PL74.55K	P74.16E	P74.21G	P74.17L	PL74.56R	-	P19.74Y	P74.43B	P99.45H	
	ONE	matte																			
		glossy																			
	CLUB																				
	WINDOW																				
<b>W 60</b> Specify hinge R or L	Code	PL74.57X	PL74.58D	P54.67C	P54.69P	P54.88S	P54.78N	PL74.59L		P54.68H	PL74.60G	PL74.61P	P54.70U	P54.89X	P54.82K	PL74.62V	PL74.29U	P54.91H	P54.92P	P55.42Y	
	ONE	matte																			
		glossy																			
	CLUB																				
	WINDOW																				
<b>W 90</b>	Reference images →																				
	Code	PL74.63B	PL74.64H	P74.23T	P74.26K	P74.35H	P74.29A	PL74.65Q		P74.25D	PL74.66W	PL74.67C	P74.27Q	P74.40L	P74.28V	PL74.68K	PL74.30R	P19.68R	P74.66B	P99.48Z	
	ONE	matte																			
		glossy																			
	CLUB																				
	WINDOW																				

- Components in **CARCASE** colors
- Components in **GROUP 2** colors
- Components in **Types and colors FRONT**

- With doors **W 30**
- With doors **W 30 + W 60** - Indicate R or L (drawing - R)
- Without bottom panel.

**OPTIONAL:** **p. 614** **B** - Extra colors for **SIDE PANELS**  
**D** - Drawers and big drawers with soft-close

- p. 56** Knob and handle positions
- p. 662** Tops and Bases for Modular units and Wall units
- p. 666** Adjustable feet for Modular units
- p. 668** Accessories for Modular units and Wall units

**CLUB**  
drawers and big drawers  
CHARM with soft-close "Quadro"  
type slides as standard  
(without surcharges)



# Floor/support Modular units Dpt 32.5

Complete every composition with Top and Base or Top and Feet.

		Ht 192																		
<b>W 45</b> Specify hinge R or L	Reference images →																			
	<b>Code</b>	<b>P74.60U</b>	<b>PL74.69R</b>	<b>PL74.70N</b>	<b>PL74.71U</b>	<b>P74.44G</b>	<b>P74.47Y</b>	<b>P74.52A</b>		<b>P74.42W</b>	<b>PL74.72A</b>	<b>P74.45N</b>	<b>P74.48D</b>	<b>PL74.73G</b>	<b>-</b>					
	ONE	matte																		
		glossy																		
	<b>CLUB</b>																			
	<b>WINDOW</b>																			
<b>W 60</b> Specify hinge R or L	<b>Code</b>	<b>P54.99B</b>	<b>PL74.74P</b>	<b>PL74.75V</b>	<b>PL74.76B</b>	<b>P54.93U</b>	<b>P54.95E</b>	<b>P55.04P</b>		<b>P54.94Z</b>	<b>PL74.77H</b>	<b>P54.96L</b>	<b>P55.06Z</b>	<b>PL74.78Q</b>	<b>PL74.31X</b>					
	ONE	matte																		
		glossy																		
	<b>CLUB</b>																			
	<b>WINDOW</b>																			
<b>W 90</b>	Reference images →																			
	<b>Code</b>	<b>P74.83U</b>	<b>PL74.79W</b>	<b>PL74.80T</b>	<b>PL74.81Z</b>	<b>P74.67G</b>	<b>P74.70Y</b>	<b>P74.75A</b>		<b>P74.55S</b>	<b>PL74.82F</b>	<b>P74.56X</b>	<b>P74.58H</b>	<b>PL74.83N</b>	<b>PL74.32D</b>					
	ONE	matte																		
		glossy																		
	<b>CLUB</b>																			
	<b>WINDOW</b>																			

- Components in **CARCASE** colors
- Components in **GROUP 2** colors
- Components in **Types and colors FRONT**

- With doors **W 30**
- With doors **W 30 + W 60** - Indicate R or L (drawing - R)



**OPTIONAL:** p. 614 **B** - Extra colors for **SIDE PANELS**  
**D** - Drawers and big drawers with soft-close



p. 56 Knob and handle positions  
p. 662 Tops and Bases for Modular units and Wall units  
p. 666 Adjustable feet for Modular units  
p. 668 Accessories for Modular units and Wall units

**CLUB**  
drawers and big drawers  
CHARM with soft-close "Quadro"  
type slides as standard  
(without surcharges)

# L corner Modular units Dpt 32.5 - W 90

# R corner Modular units Dpt 32.5 - W 90

	Ht 32	Ht 64	Ht 96	Ht 128	Ht 160	Ht 192
<b>Code</b>	<b>P68.02Q</b>	<b>P68.01K</b>	<b>P68.03V</b>	<b>P68.05F</b>	<b>P68.04A</b>	<b>P68.06M</b>
ONE	matte					
	glossy					
CLUB						

	Ht 32	Ht 64	Ht 96	Ht 128	Ht 160	Ht 192
<b>Code</b>	<b>P68.08X</b>	<b>P68.07S</b>	<b>P68.09C</b>	<b>P68.11P</b>	<b>P68.10H</b>	<b>P68.12U</b>
ONE	matte					
	glossy					
CLUB						

## L corner Tops Dpt 33.1

	W 90	W 135	W 150	W 180	customised W Min 61 Max 300 (matte) Max 258 (glossy)
<b>Tops Th 1.8</b>	<b>PK70.60N</b>	<b>PK70.61U</b>	<b>PK70.62A</b>	<b>PK70.63G</b>	<b>PK70.64P</b>
matte					
glossy					

## R corner Tops Dpt 33.1

	W 90	W 135	W 150	W 180	customised W Min 61 Max 300 (matte) Max 258 (glossy)
<b>Tops Th 1.8</b>	<b>PK70.70T</b>	<b>PK70.71Z</b>	<b>PK70.72F</b>	<b>PK70.73N</b>	<b>PK70.74U</b>
matte					
glossy					

## L corner Countertops Dpt 33.1

	W 48	W 63	W 93	customised W Min 30 Max 300 (matte) Max 258 (glossy)
<b>Tops Th 1.8</b>	<b>PK70.65V</b>	<b>PK70.66B</b>	<b>PK70.67H</b>	<b>PK70.68Q</b>
matte				
glossy				

## R corner Countertops Dpt 33.1

	W 48	W 63	W 93	customised W Min 30 Max 300 (matte) Max 258 (glossy)
<b>Tops Th 1.8</b>	<b>PK70.75A</b>	<b>PK70.76G</b>	<b>PK70.77P</b>	<b>PK70.78V</b>
matte				
glossy				

## L corner Tops and Bases Dpt 33.3

	W 90	W 135	W 150	W 180	customised W Min 61 Max 360
<b>Tops Th 2.5</b>	<b>PL69.01Z</b>	<b>PL69.02F</b>	<b>PL69.03N</b>	<b>PL69.04U</b>	<b>PL69.05A</b>
<b>Bases Ht 3</b>	<b>PL69.11E</b>	<b>PL69.12M</b>	<b>PL69.13T</b>	<b>PL69.14Z</b>	<b>PL69.15F</b>

## R corner Tops and Bases Dpt 33.3

	W 90	W 135	W 150	W 180	customised W Min 61 Max 360
<b>Tops Th 2.5</b>	<b>PL69.06G</b>	<b>PL69.07P</b>	<b>PL69.08V</b>	<b>PL69.09B</b>	<b>PL69.10Y</b>
<b>Bases Ht 3</b>	<b>PL69.16N</b>	<b>PL69.17U</b>	<b>PL69.18A</b>	<b>PL69.19G</b>	<b>PL69.20D</b>

## L corner Countertops and Counterbases Dpt 33.3

	W 47.8	W 62.8	W 92.8	customised W Min 2.8 Max 360
<b>Tops Th 2.5</b>	<b>PL69.21L</b>	<b>PL69.22S</b>	<b>PL69.23Y</b>	<b>PL69.24E</b>
<b>Bases Ht 3</b>	<b>PL69.31R</b>	<b>PL69.32X</b>	<b>PL69.33D</b>	<b>PL69.34L</b>

## R corner Countertops and Counterbases Dpt 33.3

	W 47.8	W 62.8	W 92.8	customised W Min 2.8 Max 360
<b>Tops Th 2.5</b>	<b>PL69.26T</b>	<b>PL69.27Z</b>	<b>PL69.28F</b>	<b>PL69.29N</b>
<b>Bases Ht 3</b>	<b>PL69.36Y</b>	<b>PL69.37E</b>	<b>PL69.38M</b>	<b>PL69.39T</b>

- Components in **CARCASE** colors
- Components in **GROUP 1** colors
- Components in **GROUP 2** colors
- Components in **Types and colors FRONT**
- When using this element it is essential to send a drawing

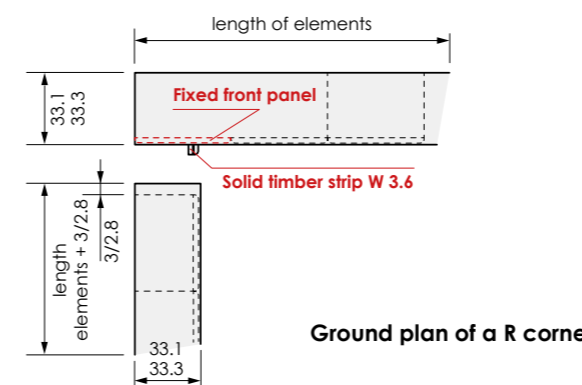
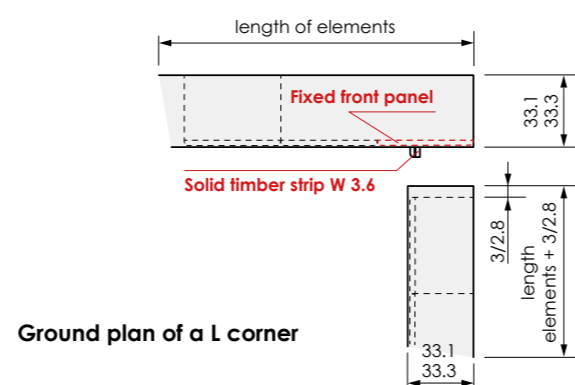

**OPTIONAL: B** - Extra colors for SIDE PANELS  
p. 614





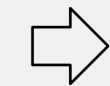

p. 56 Knob and handle positions  
p. 666 Adjustable feet for Modular units  
p. 668 Accessories for Modular units and Wall units

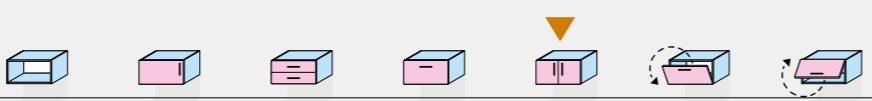

# Hanging Modular units Dpt 45

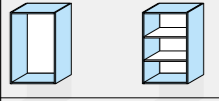
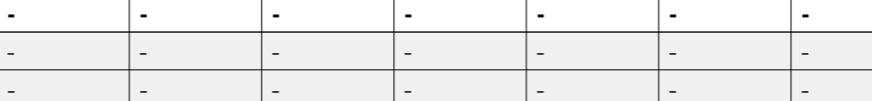
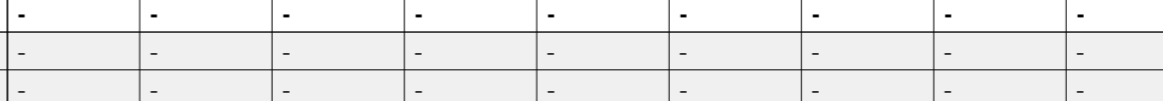
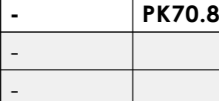
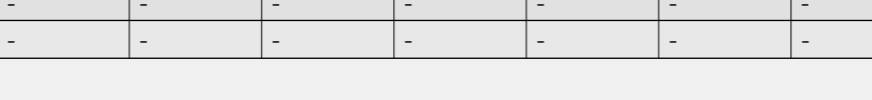
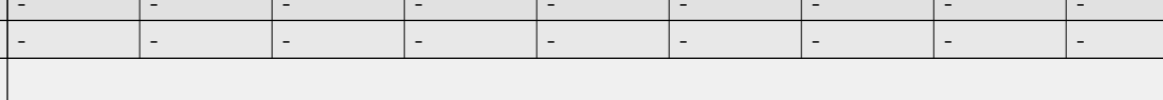
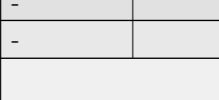
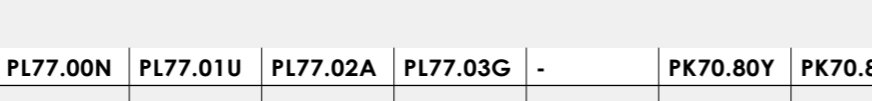
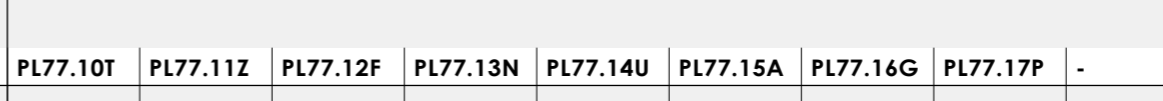
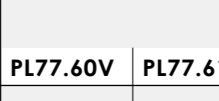



It is advisable to complete every composition with the Top.

Reference images →

	Ht 32							Ht 64										Ht 96							
<b>W 30</b> Specify hinge R or L																									
<b>Code</b>	-	-	-	-	-	-	-	-	-	-	-	-	-	-	-	-	-	-	-	-	-	-	-	-	PK70.88A
ONE <b>matte</b>	-	-	-	-	-	-	-	-	-	-	-	-	-	-	-	-	-	-	-	-	-	-	-	-	-
ONE <b>glossy</b>	-	-	-	-	-	-	-	-	-	-	-	-	-	-	-	-	-	-	-	-	-	-	-	-	-
CLUB	-	-	-	-	-	-	-	-	-	-	-	-	-	-	-	-	-	-	-	-	-	-	-	-	-
WINDOW	-	-	-	-	-	-	-	-	-	-	-	-	-	-	-	-	-	-	-	-	-	-	-	-	-
<b>W 45</b> Specify hinge R or L																									
<b>Code</b>	PL77.00N	PL77.01U	PL77.02A	PL77.03G	-	PK70.80Y	PK70.81E	PL77.10T	PL77.11Z	PL77.12F	PL77.13N	PL77.14U	PL77.15A	PL77.16G	PL77.17P	-	PL77.60V	PL77.61B							
ONE <b>matte</b>																									
ONE <b>glossy</b>																									
CLUB																									
WINDOW																									
<b>W 60</b> Specify hinge R or L																									
<b>Code</b>	PL77.18V	PL77.19B	PL77.20Y	PL77.21E	PL77.22M	PK70.82M	PK70.83T	PL77.29G	PL77.30D	PL77.31L	PL77.32S	PL77.33Y	PL77.34E	PL77.35M	PL77.36T	PL77.37Z	PL77.75H	PL77.76Q							
ONE <b>matte</b>																									
ONE <b>glossy</b>																									
CLUB																									
WINDOW																									
<b>W 90</b>																									
<b>Code</b>	PL77.38F	PL77.39N	PL77.40K	PL77.41R	PL77.42X	PK70.84Z	PK70.85F	PL77.49T	PL77.50Q	PL77.51W	PL77.52C	PL77.53K	PL77.54R	PL77.55X	PL77.56D	PL77.57L									
ONE <b>matte</b>																									
ONE <b>glossy</b>																									
CLUB																									
WINDOW																									
<b>W 120 - 135 - 150 - 180</b>																									
<b>Code</b>	PK70.59R	PK70.99N	PK70.03Z	PK70.04F	PK70.05N	PK70.06U	PK70.07A	PK70.08G																	
ONE <b>matte</b>																									
ONE <b>glossy</b>																									
CLUB																									
WINDOW																									

 Components in **CARCASE** colors  
 Components in **GROUP 2** colors  
 Components in **Types and colors FRONT**

 **With doors W 30**  
 **With doors W 30 + W 60** - Indicate R or L (drawing - R)



**OPTIONAL: p. 614**

- A** · Extra colors for Top panel and Bottom panel
- B** · Extra colors for SIDE PANELS
- D** · Drawers and big drawers with soft-close

**CLUB**  
drawers and big drawers  
CHARM with soft-close "Quadro"  
type slides as standard  
(without surcharges)

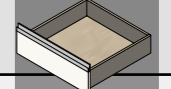

**p. 56** Knob and handle positions  
**p. 662** Tops and Bases for Modular units and Wall units  
**p. 668** Accessories for Modular units and Wall units

# Hanging Modular units Dpt 45

It is advisable to complete every composition with the Top.

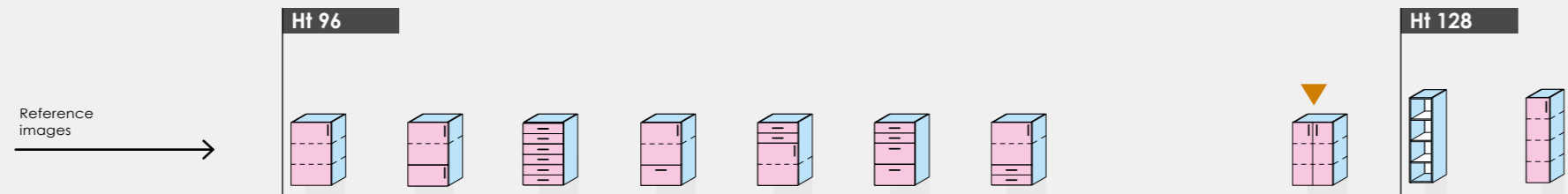

W 30 Specify hinge R or L	Code	PK70.89G	-	-	-	-	-	-	-	PK70.90D	PK70.91L							
	ONE	matte																
	glossy																	
	CLUB																	
	WINDOW																	
W 45 Specify hinge R or L	Code	PL77.62H	PL77.96A	PL77.63Q	PL77.64W	PL77.65C	PL77.66K	PL77.67R	-	-	-							
	ONE	matte																
	glossy																	
	CLUB																	
	WINDOW																	
W 60 Specify hinge R or L	Code	PL77.77W	PL77.97G	PL77.78C	PL77.79K	PL77.80F	PL77.81N	PL77.82U		PL77.83A	-	-						
	ONE	matte																
	glossy																	
	CLUB																	
	WINDOW																	
W 90	Code																	
	ONE	matte																
	glossy																	
	CLUB																	
	WINDOW																	

Components in **CARCASE** colors  
 Components in **GROUP 2** colors  
 Components in **Types and colors FRONT**

With doors W 30

**OPTIONAL:**  
**p. 614** A · Extra colors for Top panel and Bottom panel  
 B · Extra colors for SIDE PANELS  
 D · Drawers and big drawers with soft-close

**p. 56** Knob and handle positions  
**p. 662** Tops and Bases for Modular units and Wall units  
**p. 668** Accessories for Modular units and Wall units

**CLUB**  
 drawers and big drawers  
 CHARM with soft-close "Quadro"  
 type slides as standard  
 (without surcharges)

# Hanging Modular units Dpt 32.5



It is advisable to complete every composition with the Top.

	Ht 32						Ht 64										Ht 96			
<b>W 45</b> Specify hinge R or L	Reference images →																			
	<b>Code</b>	P94.22S	P94.09W	PL79.00W	PL79.01C	-	PK70.92S	P94.34G		P94.35N	P94.25H	PL79.04X	PL79.05D	PL79.06L	PL79.07S	PL79.08Y	-	PL79.30N	PL79.31U	PL79.32A
	ONE	matte glossy																		
	CLUB																			
WINDOW																				
<b>W 60</b> Specify hinge R or L	<b>Code</b>	P94.23X	P94.13T	PL79.09E	PL79.10B	PL79.11H	PK70.93Y	P94.36T		P94.37Y	P94.28Z	PL79.14C	PL79.15K	PL79.16R	PL79.17X	PL79.18D	PL79.19L	PL79.43N	PL79.44U	PL79.45A
	ONE	matte glossy																		
	CLUB																			
	WINDOW																			
<b>W 90</b>	Reference images →																			
	<b>Code</b>	P94.24C	P94.17Q	PL79.20G	PL79.21P	PL79.22V	PK70.94E	P94.38D		P94.39K	P94.31R	PL79.23B	PL79.24H	PL79.25Q	PL79.26W	PL79.27C	PL79.28K			
	ONE	matte glossy																		
	CLUB																			
WINDOW																				
<b>W 120 - 135</b>																				
	<b>Code</b>	PK70.09P	PK70.96T																	
	ONE	matte glossy																		
	CLUB																			
WINDOW																				

- Components in **CARCASE** colors
- Components in **GROUP 2** colors
- Components in **Types and colors FRONT**
- With doors **W 30**
- With doors **W 30 + W 60** - Indicate R or L (drawing - R)

**OPTIONAL:** **p. 614**  
**A** · Extra colors for Top panel and Bottom panel  
**B** · Extra colors for SIDE PANELS  
**D** · Drawers and big drawers with soft-close

**p. 56** Knob and handle positions  
**p. 662** Tops and Bases for Modular units and Wall units  
**p. 668** Accessories for Modular units and Wall units

**CLUB**  
 drawers and big drawers  
 CHARM with soft-close "Quadro"  
 type slides as standard  
 (without surcharges)

# Hanging modular units Dpt 32.5

It is advisable to complete every composition with the Top.

Ht 96

Reference images →



## W 45

Specify hinge R or L

Code	PL79.57U	PL79.33G	PL79.34P	PL79.35V	PL79.36B	PL79.37H	-												
ONE																			
CLUB																			
WINDOW																			

## W 60

Specify hinge R or L

Code	PL79.58A	PL79.46G	PL79.47P	PL79.48V	PL79.49B	PL79.50Y	PL79.51E												
ONE																			
CLUB																			
WINDOW																			

Reference images →

## W 90

Code																			
ONE																			
CLUB																			
WINDOW																			

- Components in **CARCASE** colors
- Components in **GROUP 2** colors
- Components in **Types and colors FRONT**

▼ With doors W 30



**OPTIONAL:**  
**p. 614** A · Extra colors for Top panel and Bottom panel  
 B · Extra colors for SIDE PANELS  
 D · Drawers and big drawers with soft-close



**p. 56** Knob and handle positions  
**p. 662** Tops and Bases for Modular units and Wall units  
**p. 668** Accessories for Modular units and Wall units

**CLUB**  
 drawers and big drawers  
 CHARM with soft-close "Quadro"  
 type slides as standard  
 (without surcharges)



# Wall units Dpt 32.5

Is not obligatory to use the Top.

		Hi 32					Hi 64					Hi 96					Hi 128	
<b>W 30</b> Specify hinge R or L	Reference images →																	
	<b>Code</b>	PL83.90X	PL83.91D	-	-	-	PL83.93S	PL83.94Y	-	-	PL83.96M	PL83.97T	-	-	-	-	PL83.88U	PL83.99F
	ONE <input type="checkbox"/> matte <input type="checkbox"/> glossy																	
	CLUB WINDOW																	
<b>W 45</b> Specify hinge R or L	<b>Code</b>	P74.80C	P74.68N	-	PK71.00K	PK71.01R	PL83.04Z	P94.42A	PL83.05F	-	PL83.07U	PL83.08A	PL83.39Y	PL83.09G	PL83.37L	-		
	ONE <input type="checkbox"/> matte <input type="checkbox"/> glossy																	
	CLUB WINDOW																	
<b>W 60</b> Specify hinge R or L	<b>Code</b>	P53.57V	P53.59F	PL83.10D	PK71.02X	PK71.03D	PL83.15M	P94.44M	PL83.16T	PL83.17Z	PL83.19N	PL83.20K	PL83.40V	PL83.21R	PL83.31W	PL83.32C		
	ONE <input type="checkbox"/> matte <input type="checkbox"/> glossy																	
	CLUB WINDOW																	
<b>W 90</b>	Reference images →																	
	<b>Code</b>	P74.81H	P74.69T	PL83.22X	PK71.04L	PK71.05S	PL83.23D	P94.46X	PL83.24L	PL83.25S								
	ONE <input type="checkbox"/> matte <input type="checkbox"/> glossy																	
	CLUB WINDOW																	
<b>W 120 - 135 - 150 - 180</b>																		
	<b>Code</b>	PK71.16D	PK71.17L	PK71.10Q	PK71.11W	PK71.12C			PK71.13K	PK71.14R	PK71.15X							
	ONE <input type="checkbox"/> matte <input type="checkbox"/> glossy																	
	CLUB WINDOW																	

- Components in **CARCASE** colors
- Components in **GROUP 2** colors
- Components in **Types and colors FRONT**
- With doors **W 30**
- With doors **W 30 + W 60** - Indicate R or L (drawing - R)

**OPTIONAL:** **p. 614** **A** · Extra colors for Top panel and Bottom panel  
**B** · Extra colors for SIDE PANELS

**p. 56** Knob and handle positions  
**p. 662** Tops and Bases for Modular units and Wall units  
**p. 668** Accessories for Modular units and Wall units



# Tops and bases for modular units and wall units

## Tops Th 5.5

They are not finished in the back, it is recommended to use it against the wall.

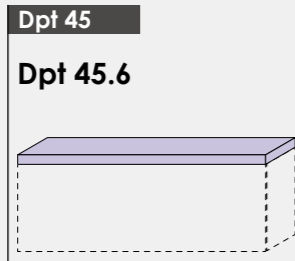

W	Code
90	PK72.00P
120	PK72.01V
135	PK72.02B
180	PK72.03H
225	PK72.04Q
270	PK72.05W
300	PK72.06C
<b>Custom-made</b> Max 295 Min 90.1	PK72.90N

## Bases Ht 6.2

With adjustable feet Ht 0.7 included.  
Other types of adjustable feet cannot be used.

They are not finished in the back, it is recommended to use it against the wall.

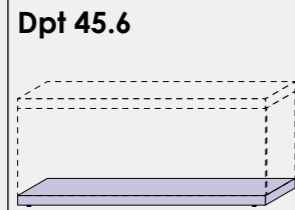

## Tops Th 5.5 - Dpt 45.6

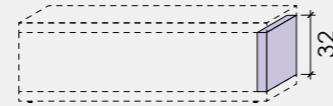

W	Code
90	PK72.07K
120	PK72.08R
135	PK72.09X
180	PK72.10U
225	PK72.11A
270	PK72.12G
300	PK72.13P
<b>Custom-made</b> Max 295 Min 90.1	PK72.91U

Code	PK72.14V

## Cushion Th 6

To be used resting on the top.  
Removable covers

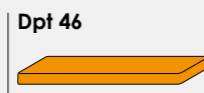
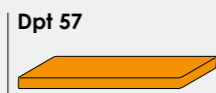

W	Code	Code
60	PK72.94P	PK72.96B
90	PK72.95V	PK72.97H

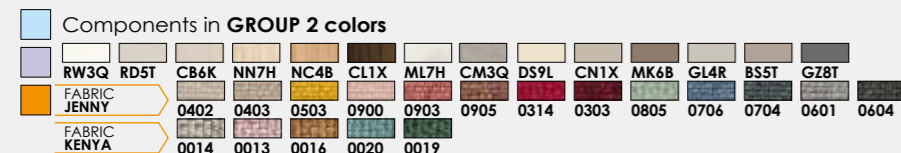

## Tops Th 2.5

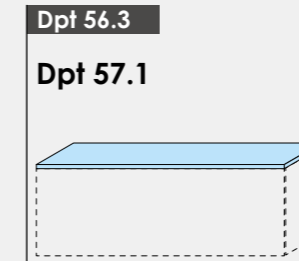

W	Code
30	PK72.15B
45	P77.01H
60	P77.02P
90	P77.03U
105	PK72.16H
120	P93.96R
135	P77.04Z
150	PK72.17Q
165	PK72.18W
180	P77.05E
225	P77.06L
240	PK72.19C
270	P77.07R
<b>Custom-made</b> Max 360 Min 30.1	P77.08W

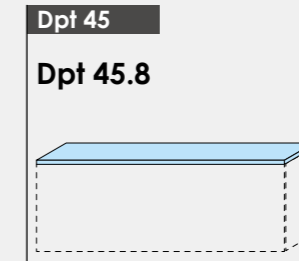

Code
PK72.20Z
P77.17V
P77.18A
P77.19F
PK72.21F
PL76.01Q
P77.20M
PK72.22N
PK72.23U
P77.21S
P77.22X
PK72.24A
P77.23C
P77.24H

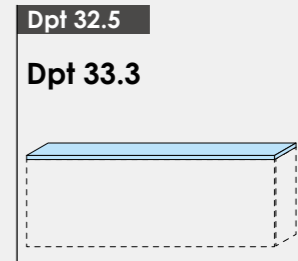

Code
PK72.25G
P70.91Z
P70.92E
P70.93L
PK72.26P
PL76.51S
P70.94R
PK72.27V
PK72.28B
P70.95W
P70.96B
PK72.29H
P70.97G
P70.98N

## Bases Ht 3

With pads Ht 0.5 included.

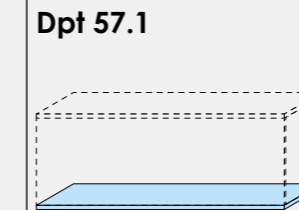

W	Code
30	PK72.30E
45	P77.09B
60	P77.10G
90	P77.11N
105	PK72.31M
120	P93.97W
135	P77.12T
150	PK72.32T
165	PK72.33Z
180	P77.13Y
225	P77.14D
240	PK72.34F
270	P77.15K
<b>Custom-made</b> Max 360 Min 30.1	P77.16Q

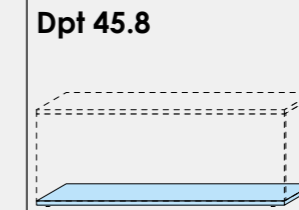

Code
PK72.35N
P77.71P
P77.72U
P77.73Z
PK72.36U
PL76.02W
P77.74E
PK72.37A
PK72.38G
P77.75L
P77.76R
PK72.39P
P77.77W
P77.78B

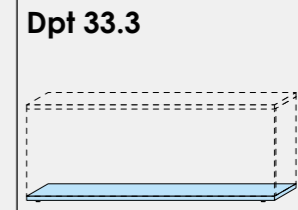

Code
PK72.40L
P73.91K
P73.92Q
P73.93V
PK72.41S
PL76.52Y
P73.94A
PK72.42Y
PK72.43E
P73.95F
P73.96M
PK72.44M
P73.97S
P73.98X

# Tops and bases for modular units and wall units

## Tops Th 1.8

W	Dpt 56.3			Dpt 45			Dpt 32.5		
	Code	matte	glossy	Code	matte	glossy	Code	matte	glossy
30	PK72.45T			PK72.59Z			PK72.73W		
45	PK72.46Z			PK72.60W			PK72.74C		
60	PK72.47F			PK72.61C			PK72.75K		
90	PK72.48N			PK72.62K			PK72.76R		
105	PK72.49U			PK72.63R			PK72.77X		
120	PK72.50R			PK72.64X			PK72.78D		
135	PK72.51X			PK72.65D			PK72.79L		
150	PK72.52D			PK72.66L			PK72.80G		
165	PK72.53L			PK72.67S			PK72.81P		
180	PK72.54S			PK72.68Y			PK72.82V		
225	PK72.55Y			PK72.69E			PK72.83B		
240	PK72.56E			PK72.70B			PK72.84H		
270	PK72.57M			PK72.71H			PK72.85Q		
Custom-made Max 300 (258 for glossy) Min 30.1	PK72.58T			PK72.72Q			PK72.86W		

## Tops Th 1.4

W	Dpt 56.3		Dpt 45		Dpt 32.5	
	Code		Code		Code	
30	PK77.13L		PK77.20W		PK77.40G	
45	PK77.00L		PK77.21C		PK77.41P	
60	PK77.01S		PK77.22K		PK77.42V	
90	PK77.02Y		PK77.23R		PK77.43B	
105	PK77.03E		PK77.24X		PK77.44H	
120	PK77.04M		PK77.25D		PK77.45Q	
135	PK77.05T		PK77.26L		PK77.46W	
150	PK77.06Z		PK77.27S		PK77.47C	
165	PK77.07F		PK77.28Y		PK77.48K	
180	PK77.08N		PK77.29E		PK77.49R	
225	PK77.09U		PK77.30B		PK77.50N	
240	PK77.10R		PK77.31H		PK77.51U	
270	PK77.11X		PK77.32Q		PK77.52A	
Custom-made Max 300 Min 30.1	PK77.12D		PK77.33W		PK77.53G	

## Cushion Th 6

To be used resting on the top.  
Removable covers

W	Dpt 57		Dpt 46	
	Code		Code	
60	PK72.94P		PK72.96B	
90	PK72.95V		PK72.97H	

Components in **GROUP 1 colors**  
 Components in **GROUP 3 colors**

**FABRIC JENNY** 0402 0403 0503 0900 0903 0905 0314 0303 0805 0706 0704 0601 0604  
**FABRIC KENYA** 0014 0013 0016 0020 0019

# Adjustable feet for modular units

## Feet use: without Base

One pack of 4 feet for fixing underneath each element.

\* Elements W 120, 135 and 150 have an extra central foot. In the case of high feet, the central GAMMA is used.

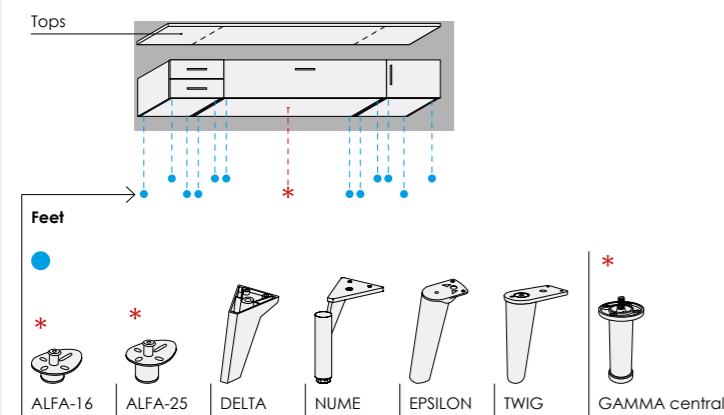

## Feet use: with Base

One pack of 4 feet for fixing at the ends plus one GAMMA central feet for placing at each joint between units are always required.

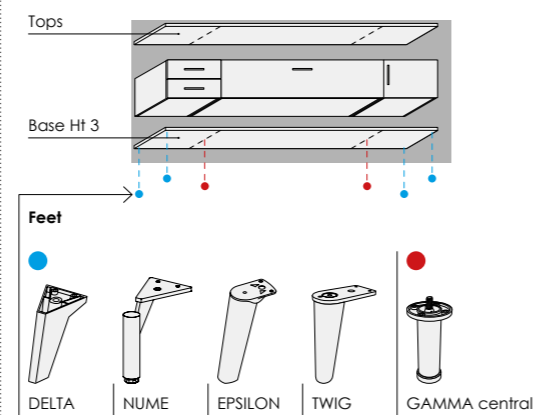

# ROUND desk Ht 72 - Dpt 45.6

## Swivel top and side Th 5.5

Modular element W 90 complete with ALFA-25 feet.

Custom cuts are not possible.

The swivel top can support a max load of 30 Kg, evenly distributed.

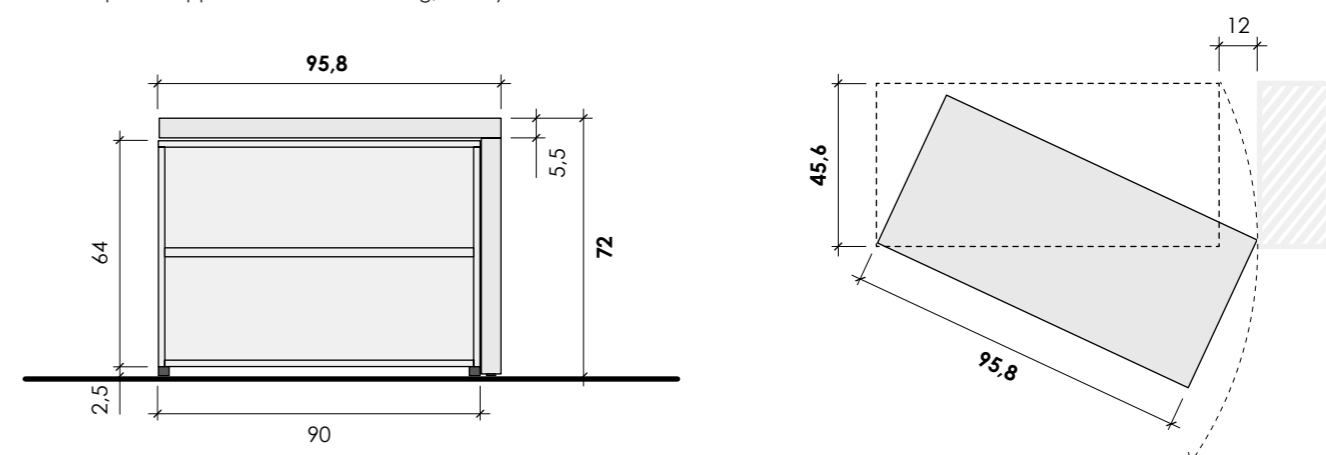

## Adjustable feet

**ALFA-16**  
Ht 1,6

4 feet

For base units W 45 - 60 - 90 - 180  
(in this last case 2 sets)



Code **PK72.87C**

**ALFA-25**  
Ht 2,5

5 feet

For base units W 120 - 135 - 150  
(in this last case 2 sets)



Code **P13.64Z**

5 feet

For base units W 45 - 60 - 90 - 180  
(in this last case 2 sets)



Code **PK72.98Q**

4 feet

For base units W 120 - 135 - 150  
(in this last case 2 sets)

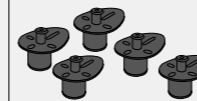

Code **PK72.99W**

## Adjustable feet

**DELTA**  
Ht 11

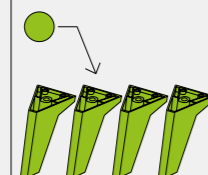

Code **P07.60P**

**NUME**  
Ht 11

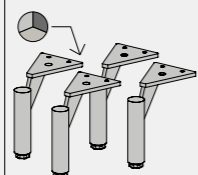

Code **PK50.00Y**

**GAMMA-11 central**  
Ht 11

W 3,6



Code **P08.33V**

## Adjustable feet

**EPSILON**  
Ht 15,5

W 4,5

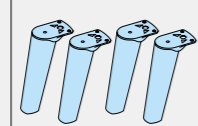

Code **P08.37S**

**TWIG**  
Ht 16

W 4,8

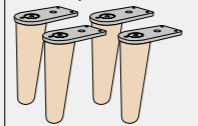

Code **PK50.01E**

**GAMMA-15,5 central**  
Ht 15,5-16

W 3,6

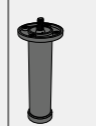

Code **PK72.88K**

Components in **GROUP 2 colors**  
Components in **Types and colors FRONT**

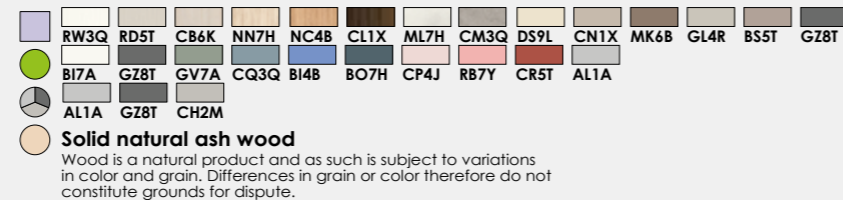

**OPTIONAL:**  
p. 614

- A · Extra colors for Top panel and Bottom panel
- B · Extra colors for SIDE PANELS
- D · Drawers and big drawers with soft-close

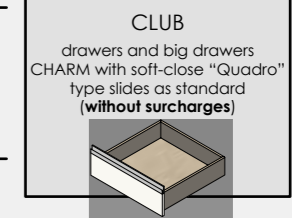

p. 56 Knob and handle positions  
p. 668 Accessories for Modular units and Wall units

# Accessories for modular units and wall units

## Dpt 56.3

	Movable shelves Th 2,5 Dpt 51,5	Movable shelves with led Th 2,5 Dpt 50,5	Transparent tempered glass movable shelf Th 0,8 Dpt 51	Partition movable shelves Th 2,5 Dpt 53 <small>Only for use as dividing surface between door sections and between door sections and drawers.</small>	BASIC clothes hanging bar	PLUS clothes hanging bar	Hanging shoe rack For mounting on inner side. W 45+70
<b>W</b>	<b>Code</b>	<b>Code</b>	<b>Code</b>	<b>Code</b>	<b>Code</b>	<b>Code</b>	<b>Code</b>
45 (41.3)	P08.75Y	P02.71G	-	P08.78K	P50.79E	PK01.43C	P48.55Y
60 (56.3)	P08.76D	P02.72N	-	P08.79V	P26.49E	PK01.44K	
90 (86.3)	P08.77K	P02.73T	PL04.13B	P08.80A	P50.81R	PK01.45R	

## Dpt 45

	Movable shelves Th 2,5 Dpt 41,7	Movable shelves with led Th 2,5 Dpt 40,7	Transparent tempered glass movable shelves Th 0,8 Dpt 41,2	Back panel retainer in metal For modular units without bottom panel.	Sliding clothes hanging bar Dpt 40
<b>W</b>	<b>Code</b>	<b>Code</b>	<b>Code</b>	<b>Code</b>	<b>Code</b>
30 (26.3)	PK72.92A	-	PK72.93G	-	P50.95S
45 (41.3)	P50.60B	P02.74Y	P51.74F	P28.02F	
60 (56.3)	P26.59K	P02.75D	P26.60Q	P54.20X	
90 (86.3)	P50.62N	P02.76K	P51.75M	P28.04S	

## Dpt 32.5

	Movable shelves Th 2,5 Dpt 28,6	Movable shelves with led Th 2,5 Dpt 27,6	Transparent tempered glass movable shelves Th 0,8 Dpt 28	Back panel retainer in metal For modular units without bottom panel.	Sliding clothes hanging bar Dpt 24,5
<b>W</b>	<b>Code</b>	<b>Code</b>	<b>Code</b>	<b>Code</b>	<b>Code</b>
30 (26.3)	P07.76A	-	P07.24T	-	P48.50W
45 (41.3)	P36.72G	P08.81F	P07.25Y	P06.97M	
60 (56.3)	P37.80D	P08.82M	P07.26D	P06.98S	
90 (86.3)	P36.71B	P08.83S	P07.27K	P06.99X	

	HIP Melamine-coated. Ht 29,4 Dpt 25 W 18	HOP Melamine-coated. Ht 29,4 Dpt 25 W 30	Led spotlights Ø 6.5 12 volt 1.7 watt.	Wireless switch For led lighting (usable for shelves and for spotlight).	ABS cable hole Hole executed by the customer. Ø 8	Metal cable hole Hole executed by the customer. Ø 8	Wireless charging Hole executed by the customer. Ø 8	BERNARDO Clothes hangers. For Floor modular units. Dpt 2 W 28
<b>Code</b>	P01.39E	P01.40L	PL86.17N	PL86.18U	P37.79Y	PK72.89R	P08.34A	P07.70T

- Components in **CARCASE** colors
- Components in **GROUP 2** colors
- AL1A  GZ8T
- B17A  GZ8T

<sup>1</sup> Wireless charging:  
Qi wireless charging standard

# Sideboards Dpt 45.6 with outer box Th 1.8

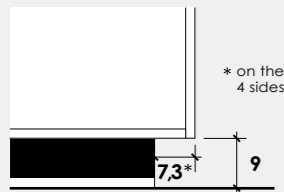

**With plinth**  
(Grigio titanio - GZ8T)

Ht 44,6



<b>Code</b>	PK75.00B	PK75.01H	PK75.02Q	PK75.03W	PK75.04C		PK75.10G	PK75.11P	PK75.12V	PK75.13B	PK75.14H
ONE	matte										
	glossy										
CLUB											
WINDOW											

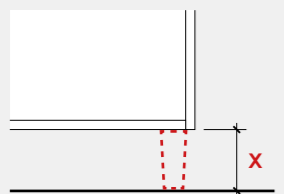

**For feet**  
When placing the order, specify the type of foot (see options at bottom of page). To be quoted separately.

Ht 46,6 DELTA - NUME  
Ht 51,1 EPSILON  
Ht 51,6 TWIG



<b>Code</b>	PK75.05K	PK75.06R	PK75.07X	PK75.08D	PK75.09L		PK75.15Q	PK75.16W	PK75.17C	PK75.18K	PK75.19R
ONE	matte										
	glossy										
CLUB											
WINDOW											

- The sideboards consist of modular units whose position can be decided during assembly.
- Inner melamine shelves included, indicated by the dotted line.
- Push pull available on elements with hinge, pull-up and pull-down doors (not on CLUB and WINDOW doors).
- The drawers are equipped as standard with "Quadro" type slowed down or push pull guides (with extra charge), adjustable in height with interior in CHARM finish.

## Adjustable feet

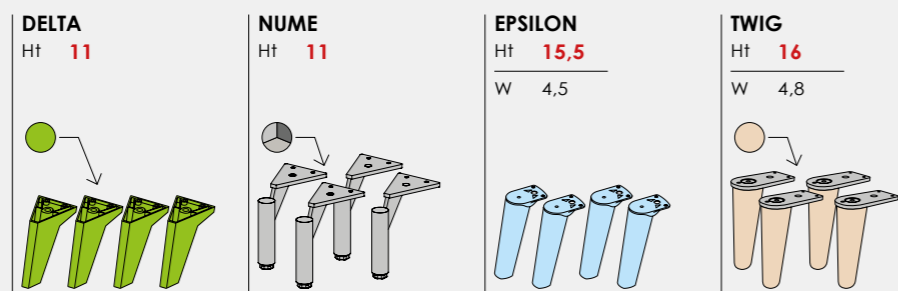

<b>Code</b>	P07.60P	PK50.00Y	P08.37S	PK50.01E						
-------------	---------	----------	---------	----------	--	--	--	--	--	--

## Feet use

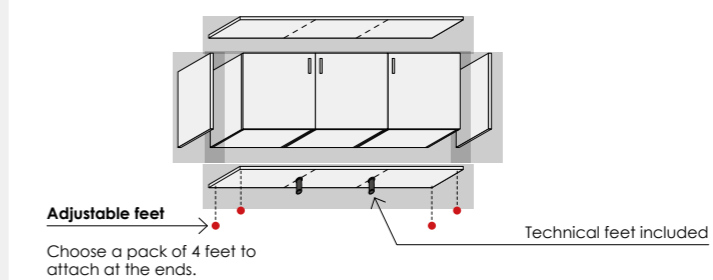

■ Components in **GROUP 2 colors**  
■ Components in **Types and colors FRONT**  
■ RW3Q RD5T NC4B GZ8T

● B17A GZ8T GV7A CQ3Q B14B BO7H CP4J R87Y CR5T AL1A  
● AL1A GZ8T CH2M  
● Solid natural ash wood  
Wood is a natural product and as such is subject to variations in color and grain. Differences in grain or color therefore do not constitute grounds for dispute.



# Sideboards Dpt 45.6 with outer box Th 1.8

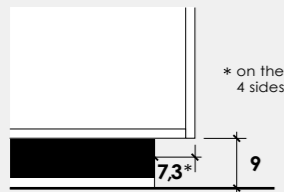

**With plinth**  
(Grigio titanio - GZ8T)

	Ht 76,6												
	138,7	153,7	183,7	183,7	183,7	183,7	183,7	183,7	183,7	213,7	213,7	243,7	
<b>Code</b>	PK75.20N	PK75.21U	PK75.22A	PK75.23G	PK75.24P	PK75.25V		PK75.32F	PK75.33N	PK75.34U	PK75.35A	PK75.36G	PK75.37P
ONE	matte												
	glossy												
CLUB													
WINDOW													

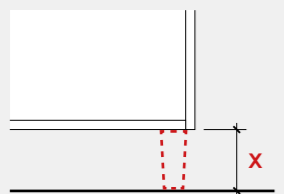

**For feet**  
When placing the order, specify the type of foot (see options at bottom of page). To be quoted separately.

	Ht 78,6 DELTA - NUME Ht 83,1 EPSILON Ht 83,6 TWIG												
	138,7	153,7	183,7	183,7	183,7	183,7	183,7	183,7	183,7	183,7	213,7	213,7	243,7
<b>Code</b>	PK75.26B	PK75.27H	PK75.28Q	PK75.29W	PK75.30T	PK75.31Z		PK75.38V	PK75.39B	PK75.40Y	PK75.41E	PK75.42M	PK75.43T
ONE	matte												
	glossy												
CLUB													
WINDOW													

- The sideboards consist of modular units whose position can be decided during assembly.
- Inner melamine shelves included, indicated by the dotted line.
- Push pull available on elements with hinge, pull-up and pull-down doors (not on CLUB and WINDOW doors).
- The drawers are equipped as standard with "Quadro" type slowed down or push pull guides (with extra charge), adjustable in height with interior in CHARM finish.

## Adjustable feet

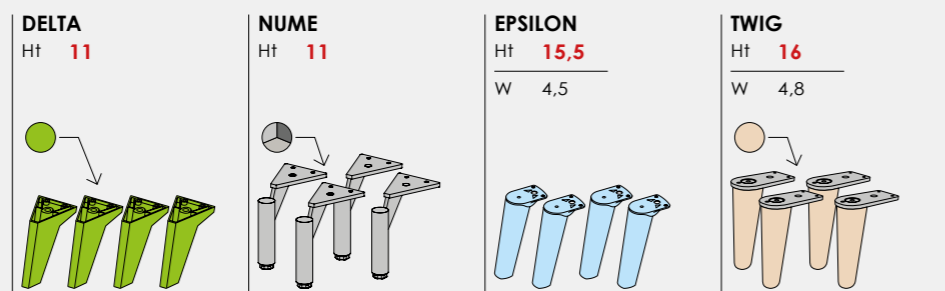

<b>Code</b>	P07.60P	PK50.00Y	P08.37S	PK50.01E								
-------------	---------	----------	---------	----------	--	--	--	--	--	--	--	--

## Feet use

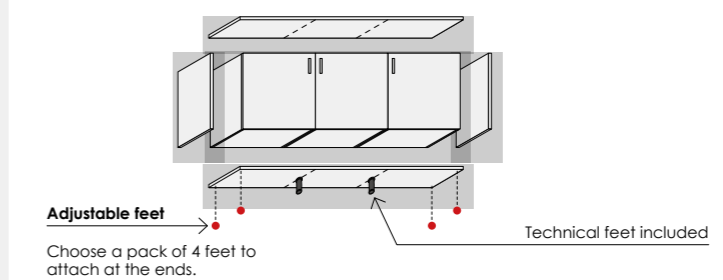

■ Components in **GROUP 2 colors**  
■ Components in **Types and colors FRONT**  
■ **RW3Q RD5T NC4B GZ8T**  
● B17A GZ8T GV7A CQ3Q B14B BO7H CP4J R87Y CR5T AL1A  
● AL1A GZ8T CH2M  
● **Solid natural ash wood**  
 Wood is a natural product and as such is subject to variations in color and grain. Differences in grain or color therefore do not constitute grounds for dispute.

# Sideboards Dpt 45.6 with outer box Th 1.8

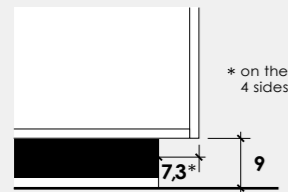

**With plinth**  
(Grigio titanio - GZ8T)

	Ht 76,6						Ht 108,6			
<b>Code</b>	PK75.44Z	PK75.45F	PK75.46N	PK75.47U	PK75.52S	PK75.53Y	PK75.54E	PK75.55M	PK75.56T	PK75.57Z
ONE	matte									
	glossy									
CLUB										
WINDOW										

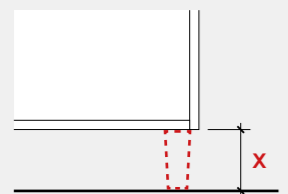

**For feet**  
When placing the order, specify the type of foot (see options at bottom of page). To be quoted separately.

	Ht 78,6 DELTA - NUME						Ht 110,6 DELTA - NUME			
	Ht 83,1 EPSILON						Ht 115,1 EPSILON			
	Ht 83,6 TWIG						Ht 115,6 TWIG			
<b>Code</b>	PK75.48A	PK75.49G	PK75.50D	PK75.51L	PK75.58F	PK75.59N	PK75.60K	PK75.61R	PK75.62X	PK75.63D
ONE	matte									
	glossy									
CLUB										
WINDOW										

- The sideboards consist of modular units whose position can be decided during assembly.
- Inner melamine shelves included, indicated by the dotted line.
- Push pull available on elements with hinge, pull-up and pull-down doors (not on CLUB and WINDOW doors).
- The drawers are equipped as standard with "Quadro" type slowed down or push pull guides (with extra charge), adjustable in height with interior in CHARM finish.

## Adjustable feet

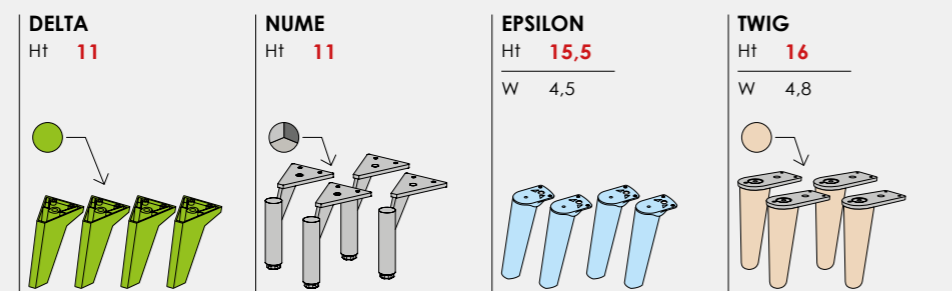

Code	P07.60P	PK50.00Y	P08.37S	PK50.01E					
------	---------	----------	---------	----------	--	--	--	--	--

■ Components in **GROUP 2 colors**  
■ Components in **Types and colors FRONT**  
■ RW3Q RD5T NC4B GZ8T  
● B17A GZ8T GV7A CQ3Q B14B BO7H CP4J R87Y CR5T AL1A  
■ AL1A GZ8T CH2M  
● Solid natural ash wood  
Wood is a natural product and as such is subject to variations in color and grain. Differences in grain or color therefore do not constitute grounds for dispute.

## Feet use

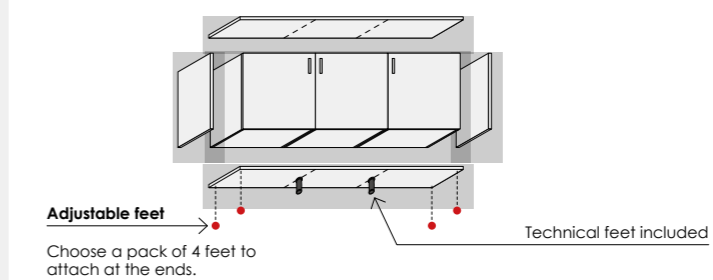

# Sideboards Dpt 45.6 with outer box Th 1.8

**With plinth**  
(Grigio titanio - GZ8T)

Ht 108,6

183,7

Ht 108,6

183,7

Ht 140,6

93,7

Ht 140,6

93,7

Ht 140,6

93,7

Ht 140,6

93,7

Ht 140,6

108,7

Ht 140,6

108,7

Ht 140,6

123,7

Ht 140,6

123,7

Ht 140,6

123,7

Ht 140,6

153,7

<b>Code</b>	PK75.64L	PK75.65S	PK75.66Y	PK75.67E	PK75.68M	PK75.74R	PK75.75X	PK75.76D	PK75.77L	PK75.78S	PK75.79Y	PK75.80V
ONE	matte											
	glossy											
CLUB												
WINDOW												

**For feet**  
When placing the order, specify the type of foot (see options at bottom of page). To be quoted separately.

Ht 110,6 DELTA - NUME  
Ht 115,1 EPSILON  
Ht 115,6 TWIG

183,7

Ht 110,6 DELTA - NUME  
Ht 115,1 EPSILON  
Ht 115,6 TWIG

183,7

Ht 142,6 DELTA - NUME  
Ht 147,1 EPSILON  
Ht 147,6 TWIG

93,7

Ht 142,6 DELTA - NUME  
Ht 147,1 EPSILON  
Ht 147,6 TWIG

93,7

Ht 142,6 DELTA - NUME  
Ht 147,1 EPSILON  
Ht 147,6 TWIG

93,7

Ht 142,6 DELTA - NUME  
Ht 147,1 EPSILON  
Ht 147,6 TWIG

93,7

Ht 142,6 DELTA - NUME  
Ht 147,1 EPSILON  
Ht 147,6 TWIG

108,7

Ht 142,6 DELTA - NUME  
Ht 147,1 EPSILON  
Ht 147,6 TWIG

108,7

Ht 142,6 DELTA - NUME  
Ht 147,1 EPSILON  
Ht 147,6 TWIG

123,7

Ht 142,6 DELTA - NUME  
Ht 147,1 EPSILON  
Ht 147,6 TWIG

123,7

Ht 142,6 DELTA - NUME  
Ht 147,1 EPSILON  
Ht 147,6 TWIG

123,7

Ht 142,6 DELTA - NUME  
Ht 147,1 EPSILON  
Ht 147,6 TWIG

153,7

<b>Code</b>	PK75.69T	PK75.70Q	PK75.71W	PK75.72C	PK75.73K	PK75.81B	PK75.82H	PK75.83Q	PK75.84W	PK75.85C	PK75.86K	PK75.87R
ONE	matte											
	glossy											
CLUB												
WINDOW												

- The sideboards consist of modular units whose position can be decided during assembly.
- Inner melamine shelves included, indicated by the dotted line.
- Push pull available on elements with hinge, pull-up and pull-down doors (not on CLUB and WINDOW doors).
- The drawers are equipped as standard with "Quadro" type slowed down or push pull guides (with extra charge), adjustable in height with interior in CHARM finish.

## Adjustable feet

<p><b>DELTA</b> Ht 11</p>	<p><b>NUME</b> Ht 11</p>	<p><b>EPSILON</b> Ht 15,5 W 4,5</p>	<p><b>TWIG</b> Ht 16 W 4,8</p>
-------------------------------	------------------------------	---	--

<b>Code</b>	P07.60P	PK50.00Y	P08.37S	PK50.01E							
-------------	---------	----------	---------	----------	--	--	--	--	--	--	--

## Feet use

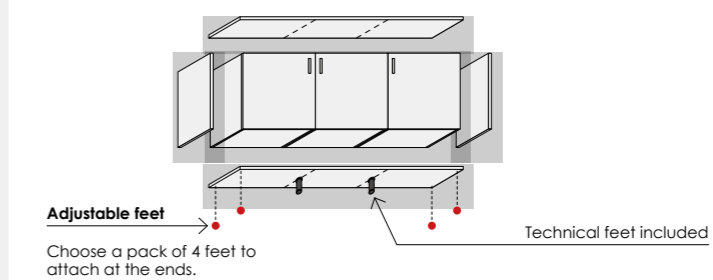

<p>Components in <b>GROUP 2 colors</b></p> <p>Components in <b>Types and colors FRONT</b></p> <p>RW3Q RD5T NC4B GZ8T</p>	<table style="width: 100%; border-collapse: collapse;"> <tr> <td style="width: 10%;">●</td> <td>B17A</td> <td style="width: 10%;">■</td> <td>GZ8T</td> <td style="width: 10%;">■</td> <td>GV7A</td> <td style="width: 10%;">■</td> <td>CQ3Q</td> <td style="width: 10%;">■</td> <td>B14B</td> <td style="width: 10%;">■</td> <td>BO7H</td> <td style="width: 10%;">■</td> <td>CP4J</td> <td style="width: 10%;">■</td> <td>R87Y</td> <td style="width: 10%;">■</td> <td>CR5T</td> <td style="width: 10%;">■</td> <td>AL1A</td> </tr> <tr> <td>●</td> <td>AL1A</td> <td>■</td> <td>GZ8T</td> <td>■</td> <td>CH2M</td> <td colspan="14"></td> </tr> </table> <p>● <b>Solid natural ash wood</b> Wood is a natural product and as such is subject to variations in color and grain. Differences in grain or color therefore do not constitute grounds for dispute.</p>	●	B17A	■	GZ8T	■	GV7A	■	CQ3Q	■	B14B	■	BO7H	■	CP4J	■	R87Y	■	CR5T	■	AL1A	●	AL1A	■	GZ8T	■	CH2M														
●	B17A	■	GZ8T	■	GV7A	■	CQ3Q	■	B14B	■	BO7H	■	CP4J	■	R87Y	■	CR5T	■	AL1A																						
●	AL1A	■	GZ8T	■	CH2M																																				



# Sideboards Dpt 45.8 with outer box Th 2.5

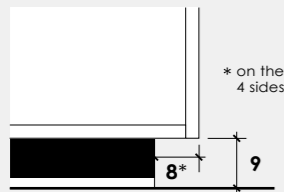

**With plinth**  
(Grigio titanio - GZ8T)

Ht 46



<b>Code</b>	PL32.16X	PL32.17D	PL32.18L	PL32.19S	PL32.20P		PL32.21V	PL32.22B	PL32.23H	PL32.24Q	PL32.25W
ONE	matte										
	glossy										
CLUB											
WINDOW											

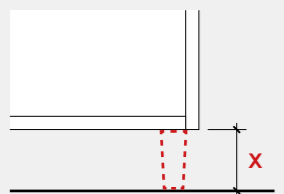

**For feet**  
When placing the order, specify the type of foot (see options at bottom of page). To be quoted separately.

Ht 48 DELTA - NUME  
Ht 52,5 EPSILON  
Ht 53 TWIG

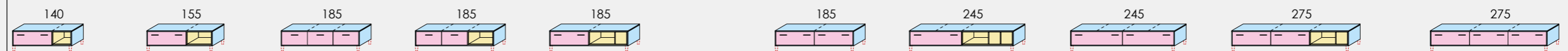

<b>Code</b>	PK76.00F	PK76.01N	PK76.02U	PK76.03A	PK76.04G		PK76.05P	PK76.06V	PK76.07B	PK76.08H	PK76.09Q
ONE	matte										
	glossy										
CLUB											
WINDOW											

- The sideboards consist of modular units whose position can be decided during assembly.
- Inner melamine shelves included, indicated by the dotted line.
- Push pull available on elements with hinge, pull-up and pull-down doors (not on CLUB and WINDOW doors).
- The drawers are equipped as standard with "Quadro" type slowed down or push pull guides (with extra charge), adjustable in height with interior in CHARM finish.

## Adjustable feet

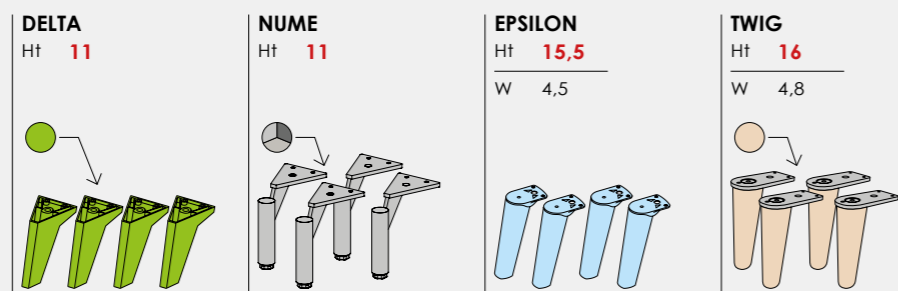

<b>Code</b>	P07.60P	PK50.00Y	P08.37S	PK50.01E					
-------------	---------	----------	---------	----------	--	--	--	--	--

## Feet use

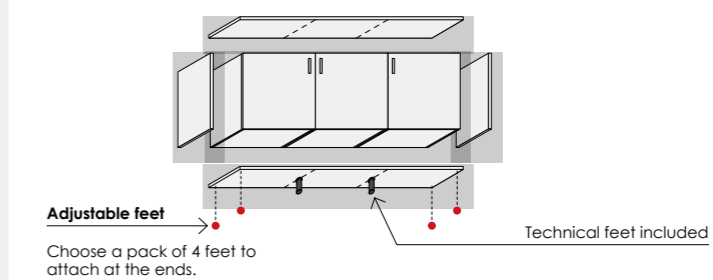

■ Components in **GROUP 2 colors**  
■ Components in **Types and colors FRONT**  
■ RW3Q RD5T NC4B GZ8T

● B17A GZ8T GV7A CQ3Q B14B BO7H CP4J R87Y CR5T AL1A  
● AL1A GZ8T CH2M  
● Solid natural ash wood  
Wood is a natural product and as such is subject to variations in color and grain. Differences in grain or color therefore do not constitute grounds for dispute.

# Sideboards Dpt 45.8 with outer box Th 2.5

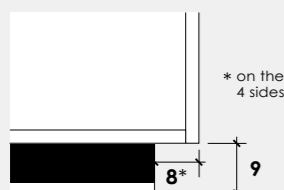

**With plinth**  
(Grigio titanio - GZ8T)

	Ht 78												
	140	155	185	185	185	185	185	185	185	215	215	245	
<b>Code</b>	PK76.10M	PK76.11T	PL32.63E	PL32.64M	PL32.65T	PK76.12Z		PL32.67F	PL32.68N	PL32.69U	PL32.70R	PK76.19V	PK76.20S
ONE	matte												
	glossy												
CLUB													
WINDOW													

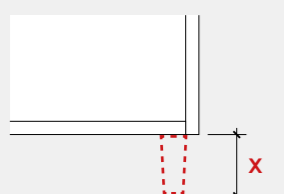

**For feet**  
When placing the order, specify the type of foot (see options at bottom of page). To be quoted separately.

	Ht 80 DELTA - NUME Ht 84,5 EPSILON Ht 85 TWIG												
	140	155	185	185	185	185	185	185	185	185	215	215	245
<b>Code</b>	PK76.13F	PK76.14N	PK76.15U	PK76.16A	PK76.17G	PK76.18P		PK76.21Y	PK76.22E	PK76.23M	PK76.24T	PK76.25Z	PK76.26F
ONE	matte												
	glossy												
CLUB													
WINDOW													

- The sideboards consist of modular units whose position can be decided during assembly.
- Inner melamine shelves included, indicated by the dotted line.
- Push pull available on elements with hinge, pull-up and pull-down doors (not on CLUB and WINDOW doors).
- The drawers are equipped as standard with "Quadro" type slowed down or push pull guides (with extra charge), adjustable in height with interior in CHARM finish.

## Adjustable feet

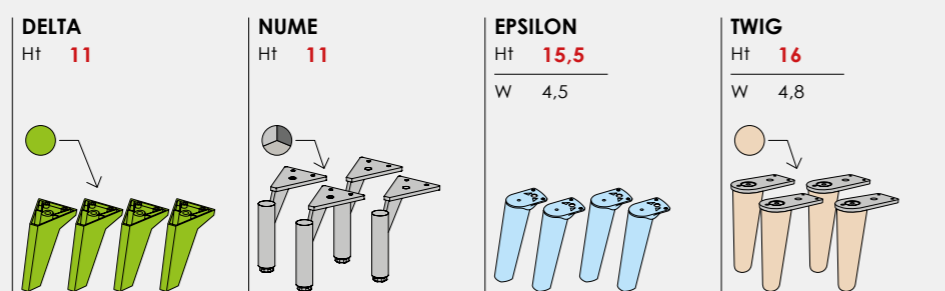

<b>Code</b>	P07.60P	PK50.00Y	P08.37S	PK50.01E									
-------------	---------	----------	---------	----------	--	--	--	--	--	--	--	--	--

## Feet use

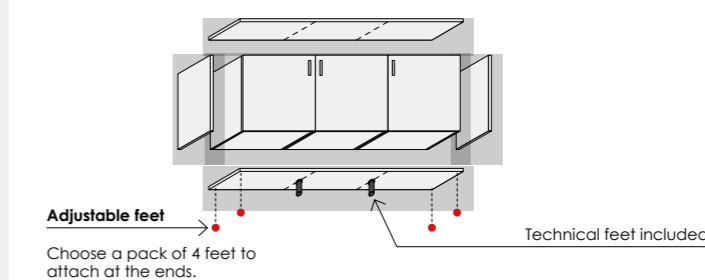

■ Components in **GROUP 2 colors**  
■ Components in **Types and colors FRONT**  
■ **RW3Q RD5T NC4B GZ8T**  
● B17A GZ8T GV7A CQ3Q B14B BO7H CP4J R87Y CR5T AL1A  
■ AL1A GZ8T CH2M  
● **Solid natural ash wood**  
Wood is a natural product and as such is subject to variations in color and grain. Differences in grain or color therefore do not constitute grounds for dispute.

# Sideboards Dpt 45.8 with outer box Th 2.5

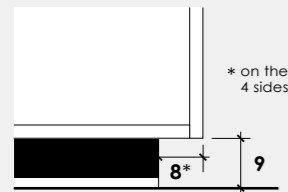

**With plinth**  
(Grigio titanio - GZ8T)

	Ht 78						Ht 110			
Code	PK76.27N	PL32.74S	PK76.28U	PL32.76E	PL32.77M	PL32.78T	PL34.31K	PL34.32R	PL34.33X	PL34.34D
ONE	matte									
	glossy									
CLUB										
WINDOW										

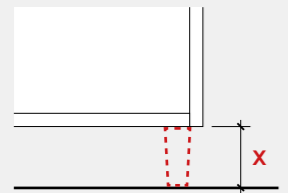

**For feet**  
When placing the order, specify the type of foot (see options at bottom of page). To be quoted separately.

	Ht 80 DELTA - NUME Ht 84,5 EPSILON Ht 85 TWIG						Ht 112 DELTA - NUME Ht 116,5 EPSILON Ht 117 TWIG			
Code	PK76.29A	PK76.30X	PK76.31D	PK76.32L	PK76.33S	PK76.34Y	PK76.35E	PK76.36M	PK76.37T	PK76.38Z
ONE	matte									
	glossy									
CLUB										
WINDOW										

- The sideboards consist of modular units whose position can be decided during assembly.
- Inner melamine shelves included, indicated by the dotted line.
- Push pull available on elements with hinge, pull-up and pull-down doors (not on CLUB and WINDOW doors).
- The drawers are equipped as standard with "Quadro" type slowed down or push pull guides (with extra charge), adjustable in height with interior in CHARM finish.

## Adjustable feet

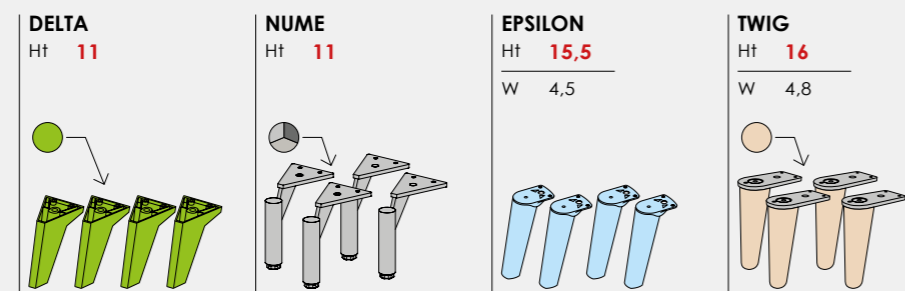

Code	P07.60P	PK50.00Y	P08.37S	PK50.01E					

■ Components in **GROUP 2 colors**  
■ Components in **Types and colors FRONT**  
■ RW3Q RD5T NC4B GZ8T  
● B17A GZ8T GV7A CQ3Q B14B BO7H CP4J R87Y CR5T AL1A  
■ AL1A GZ8T CH2M  
● Solid natural ash wood  
Wood is a natural product and as such is subject to variations in color and grain. Differences in grain or color therefore do not constitute grounds for dispute.

## Feet use

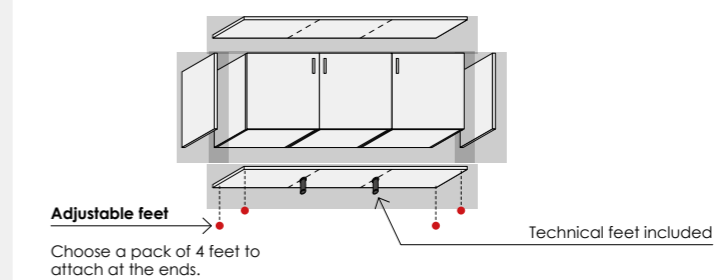



# Sideboards Dpt 45.8 with outer box Th 2.5

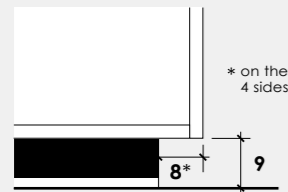

**With plinth**  
(Grigio titanio - GZ8T)

	Ht 110			Ht 142								
	185	185	95	95	95	95	110	110	125	125	125	155
<b>Code</b>	<b>PL34.35L</b>	<b>PL34.36S</b>	<b>PL34.51V</b>	<b>PL34.52B</b>	<b>PL34.53H</b>	<b>PK76.44D</b>	<b>PL34.55W</b>	<b>PL34.56C</b>	<b>PL34.57K</b>	<b>PL34.58R</b>	<b>PK76.45L</b>	<b>PL34.60U</b>
ONE	matte											
	glossy											
CLUB												
WINDOW												

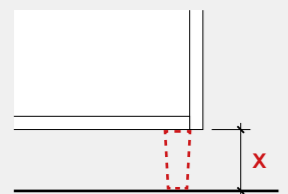

**For feet**  
When placing the order, specify the type of foot (see options at bottom of page). To be quoted separately.

	Ht 112 DELTA - NUME		Ht 116,5 EPSILON		Ht 117 TWIG		Ht 144 DELTA - NUME		Ht 148,5 EPSILON		Ht 149 TWIG	
	185	185	95	95	95	95	110	110	125	125	125	155
<b>Code</b>	<b>PK76.39F</b>	<b>PK76.40C</b>	<b>PK76.41K</b>	<b>PK76.42R</b>	<b>PK76.43X</b>	<b>PK76.46S</b>	<b>PK76.47Y</b>	<b>PK76.48E</b>	<b>PK76.49M</b>	<b>PK76.50H</b>	<b>PK76.51Q</b>	<b>PK76.52W</b>
ONE	matte											
	glossy											
CLUB												
WINDOW												

- The sideboards consist of modular units whose position can be decided during assembly.
- Inner melamine shelves included, indicated by the dotted line.
- Push pull available on elements with hinge, pull-up and pull-down doors (not on CLUB and WINDOW doors).
- The drawers are equipped as standard with "Quadro" type slowed down or push pull guides (with extra charge), adjustable in height with interior in CHARM finish.

## Adjustable feet

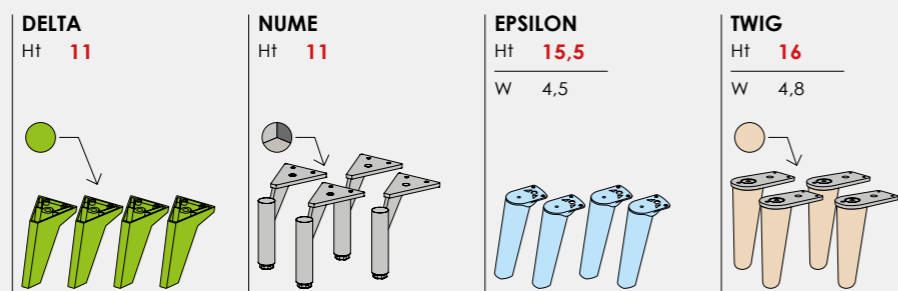

<b>Code</b>	<b>P07.60P</b>	<b>PK50.00Y</b>	<b>P08.37S</b>	<b>PK50.01E</b>
-------------	----------------	-----------------	----------------	-----------------

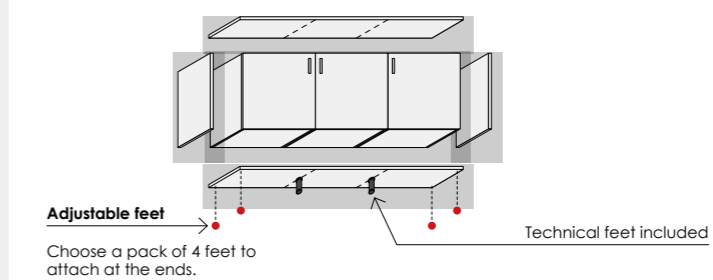

## Feet use



- Components in **GROUP 2 colors**
  - Components in **Types and colors FRONT**
  - Solid natural ash wood**
- Wood is a natural product and as such is subject to variations in color and grain. Differences in grain or color therefore do not constitute grounds for dispute.

## Accessories for sideboards with outer box

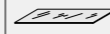

### Dpt 45

	Movable shelves	Movable shelves with led	Transparent tempered glass movable shelves
	Th 2,5 Dpt 41,7	Th 2,5 Dpt 40,7	Th 0,8 Dpt 41,2
			
W	Code	Code	Code
45 (41.3)	P50.60B	P02.74Y	P51.74F
60 (56.3)	P26.59K	P02.75D	P26.60Q
90 (86.3)	P50.62N	P02.76K	P51.75M

	Wireless switch For led lighting		
			
Code	PL86.18U		

#### INTERNAL LIGHTING

The lighting consists of: moveable melamine-faced shelves fitted with a led strip (60 LEDs per metre) positioned along the entire length of the shelf back, which lights both the lower and upper compartments by reflecting the light on the back panel. A power supply unit is supplied (with a surcharge) for the shelves that can power from 1 to 6 shelves 45/60-cm wide or 1 to 4 shelves, 90-cm wide. The type of lighting is natural. It can be switched on in 2 ways: by plugging it in and using the wall switch or by ordering a wireless switch from the price list.

-  Components in **CARCASE** colors
-  Components in **GROUP 3** colors

## INSIDE sideboards Dpt 54

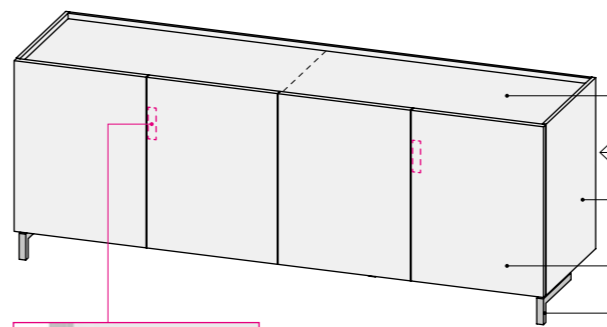

**Top Th 1.8** Internal components (internal sides, shelves and bottom) in Leather gray (LG7H) finish.

**Retrofined back panel Th 1.4**



**Side panels Th 1.4**

**Frontals Th 2.5 (without handle, top grip)**

**Metal base Ht 11.5** Metal base available in the colors: Grigio nero opaco Ral 7021 (PD10) and Carbon grey (CG8X).

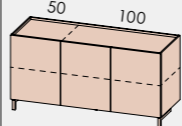
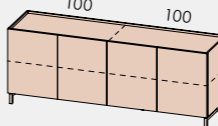
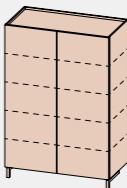
**INES handle (G89R) optional with surcharge**  
The INES handle (G89R) is supplied assembled on the door and generates a specific modification. If there are two doors, only one handle is included per element, positioned on the right-hand door.  
Available in the colours: Acciaio opaco (AP4B), Bianco opaco (BI7A), Nero opaco (NP7H).

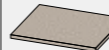
	W 150 Ht 75	W 200 Ht 75	W 104 Ht 154
			
Code	PV24.01K	PV24.02R	PV24.00C

	Movable shelves Leather gray (LG7H) finish	Transparent tempered glass movable shelves	
	Th 2,5 Dpt 44,7	Th 0,8 Dpt 44,7	
			
W	Code	Code	
50	PV20.26L	PV21.30F	
100	PV20.27S	PV21.31N	
104	PV20.28Y	PV21.32U	

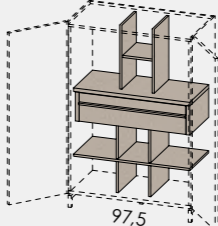
	Internal chest of drawers For Ht 75 sideboard Leather gray (LG7H) finish	Bar set-up kit For Ht 154 sideboard Leather gray (LG7H) finish
	Ht 18,5 Dpt 44,7 W 100	Ht 135,8 Dpt 43 W 104
	Drawer with integrated wooden handle and "Quadro" soft-close runners, supplied standard.	Fronts: 1 drawer with integrated wooden handle and "Quadro" soft-close runners, supplied standard. 1 pull-out top (Dpt 36 cm open). Generates specific holes. During the equipping stage, the internal shelves of the sideboard will be automatically excluded.
		
Code	PV23.24L	PV24.10H

GROUP 1 colors	Rovere Dorian <b>RD5T</b>	Rovere white <b>RW3Q</b>	Noce naturale <b>NN7H</b>	Eucalipto <b>CL1X</b>	Domy <b>DM7P</b>	Bianco UV <b>BU3Q</b>
	Ciliegio bianco <b>CB6K</b>	Malta <b>ML7H</b>	Feltro <b>FL8X</b>	Cemento Masdar <b>CM3Q</b>	Blu indaco <b>BI4B</b>	
	Noce <b>NC4B</b>	Desert <b>DS9L</b>	Canapa <b>CN1X</b>	Moka <b>MK6B</b>	Cipria <b>CP4J</b>	
	Bianco opaco <b>BI7A</b>	Grigio Dorian <b>GL4R</b>	Basalto <b>BS5T</b>	Grigio titanio <b>GZ8T</b>	Rosa bubble <b>RB7Y</b>	
	Agave <b>GV7A</b>	Verde Alpi <b>VA5T</b>	Cadaques <b>CQ3Q</b>	Giallo zafferano <b>GZ8A</b>		
	Blu opale <b>BO7H</b>			Corallo <b>CR5T</b>		

Types and colors FRONT	ONE	<table border="1"> <tr> <td>Rovere white <b>RW3Q</b></td> <td>Rovere Dorian <b>RD5T</b></td> <td>Ciliegio bianco <b>CB6K</b></td> <td>Noce naturale <b>NN7H</b></td> <td>Noce <b>NC4B</b></td> <td>Eucalipto <b>CL1X</b></td> <td>Malta <b>ML7H</b></td> </tr> <tr> <td>Feltro <b>FL8X</b></td> <td>Cemento Masdar <b>CM3Q</b></td> <td>Bianco opaco <b>BI7A</b></td> <td>Desert <b>DS9L</b></td> <td>Canapa <b>CN1X</b></td> <td>Moka <b>MK6B</b></td> <td>Grigio Dorian <b>GL4R</b></td> </tr> <tr> <td>Basalto <b>BS5T</b></td> <td>Grigio titanio <b>GZ8T</b></td> <td>Domy <b>DM7P</b></td> <td>Agave <b>GV7A</b></td> <td>Verde Alpi <b>VA5T</b></td> <td>Cadaques <b>CQ3Q</b></td> <td>Blu indaco <b>BI4B</b></td> </tr> <tr> <td>Blu opale <b>BO7H</b></td> <td>Cipria <b>CP4J</b></td> <td>Rosa bubble <b>RB7Y</b></td> <td>Giallo zafferano <b>GZ8A</b></td> <td>Corallo <b>CR5T</b></td> <td></td> <td></td> </tr> </table>							Rovere white <b>RW3Q</b>	Rovere Dorian <b>RD5T</b>	Ciliegio bianco <b>CB6K</b>	Noce naturale <b>NN7H</b>	Noce <b>NC4B</b>	Eucalipto <b>CL1X</b>	Malta <b>ML7H</b>	Feltro <b>FL8X</b>	Cemento Masdar <b>CM3Q</b>	Bianco opaco <b>BI7A</b>	Desert <b>DS9L</b>	Canapa <b>CN1X</b>	Moka <b>MK6B</b>	Grigio Dorian <b>GL4R</b>	Basalto <b>BS5T</b>	Grigio titanio <b>GZ8T</b>	Domy <b>DM7P</b>	Agave <b>GV7A</b>	Verde Alpi <b>VA5T</b>	Cadaques <b>CQ3Q</b>	Blu indaco <b>BI4B</b>	Blu opale <b>BO7H</b>	Cipria <b>CP4J</b>	Rosa bubble <b>RB7Y</b>	Giallo zafferano <b>GZ8A</b>	Corallo <b>CR5T</b>		
		Rovere white <b>RW3Q</b>	Rovere Dorian <b>RD5T</b>	Ciliegio bianco <b>CB6K</b>	Noce naturale <b>NN7H</b>	Noce <b>NC4B</b>	Eucalipto <b>CL1X</b>	Malta <b>ML7H</b>																												
Feltro <b>FL8X</b>	Cemento Masdar <b>CM3Q</b>	Bianco opaco <b>BI7A</b>	Desert <b>DS9L</b>	Canapa <b>CN1X</b>	Moka <b>MK6B</b>	Grigio Dorian <b>GL4R</b>																														
Basalto <b>BS5T</b>	Grigio titanio <b>GZ8T</b>	Domy <b>DM7P</b>	Agave <b>GV7A</b>	Verde Alpi <b>VA5T</b>	Cadaques <b>CQ3Q</b>	Blu indaco <b>BI4B</b>																														
Blu opale <b>BO7H</b>	Cipria <b>CP4J</b>	Rosa bubble <b>RB7Y</b>	Giallo zafferano <b>GZ8A</b>	Corallo <b>CR5T</b>																																
matte																																				
glossy																																				
		<table border="1"> <tr> <td>Rovere white <b>RW3Q</b></td> <td>Rovere Dorian <b>RD5T</b></td> <td>Ciliegio bianco <b>CB6K</b></td> <td>Noce naturale <b>NN7H</b></td> <td>Noce <b>NC4B</b></td> <td>Eucalipto <b>CL1X</b></td> <td>Malta <b>ML7H</b></td> </tr> <tr> <td>Feltro <b>FL8X</b></td> <td>Cemento Masdar <b>CM3Q</b></td> <td>Bianco opaco <b>BI7A</b></td> <td>Desert <b>DS9L</b></td> <td>Canapa <b>CN1X</b></td> <td>Moka <b>MK6B</b></td> <td>Grigio Dorian <b>GL4R</b></td> </tr> <tr> <td>Basalto <b>BS5T</b></td> <td>Grigio titanio <b>GZ8T</b></td> <td>Domy <b>DM7P</b></td> <td>Agave <b>GV7A</b></td> <td>Verde Alpi <b>VA5T</b></td> <td>Cadaques <b>CQ3Q</b></td> <td>Blu indaco <b>BI4B</b></td> </tr> <tr> <td>Blu opale <b>BO7H</b></td> <td>Cipria <b>CP4J</b></td> <td>Rosa bubble <b>RB7Y</b></td> <td>Giallo zafferano <b>GZ8A</b></td> <td>Corallo <b>CR5T</b></td> <td></td> <td></td> </tr> </table>							Rovere white <b>RW3Q</b>	Rovere Dorian <b>RD5T</b>	Ciliegio bianco <b>CB6K</b>	Noce naturale <b>NN7H</b>	Noce <b>NC4B</b>	Eucalipto <b>CL1X</b>	Malta <b>ML7H</b>	Feltro <b>FL8X</b>	Cemento Masdar <b>CM3Q</b>	Bianco opaco <b>BI7A</b>	Desert <b>DS9L</b>	Canapa <b>CN1X</b>	Moka <b>MK6B</b>	Grigio Dorian <b>GL4R</b>	Basalto <b>BS5T</b>	Grigio titanio <b>GZ8T</b>	Domy <b>DM7P</b>	Agave <b>GV7A</b>	Verde Alpi <b>VA5T</b>	Cadaques <b>CQ3Q</b>	Blu indaco <b>BI4B</b>	Blu opale <b>BO7H</b>	Cipria <b>CP4J</b>	Rosa bubble <b>RB7Y</b>	Giallo zafferano <b>GZ8A</b>	Corallo <b>CR5T</b>		
Rovere white <b>RW3Q</b>	Rovere Dorian <b>RD5T</b>	Ciliegio bianco <b>CB6K</b>	Noce naturale <b>NN7H</b>	Noce <b>NC4B</b>	Eucalipto <b>CL1X</b>	Malta <b>ML7H</b>																														
Feltro <b>FL8X</b>	Cemento Masdar <b>CM3Q</b>	Bianco opaco <b>BI7A</b>	Desert <b>DS9L</b>	Canapa <b>CN1X</b>	Moka <b>MK6B</b>	Grigio Dorian <b>GL4R</b>																														
Basalto <b>BS5T</b>	Grigio titanio <b>GZ8T</b>	Domy <b>DM7P</b>	Agave <b>GV7A</b>	Verde Alpi <b>VA5T</b>	Cadaques <b>CQ3Q</b>	Blu indaco <b>BI4B</b>																														
Blu opale <b>BO7H</b>	Cipria <b>CP4J</b>	Rosa bubble <b>RB7Y</b>	Giallo zafferano <b>GZ8A</b>	Corallo <b>CR5T</b>																																
		<p>Specify the color of the CLUB handle</p> <table border="1"> <tr> <td>Bianco opaco <b>BI7A</b></td> <td>Desert <b>DS9L</b></td> <td>Canapa <b>CN1X</b></td> <td>Moka <b>MK6B</b></td> <td>Grigio Dorian <b>GL4R</b></td> <td>Basalto <b>BS5T</b></td> <td>Grigio titanio <b>GZ8T</b></td> </tr> <tr> <td>Domy <b>DM7P</b></td> <td>Agave <b>GV7A</b></td> <td>Verde Alpi <b>VA5T</b></td> <td>Cadaques <b>CQ3Q</b></td> <td>Blu indaco <b>BI4B</b></td> <td>Blu opale <b>BO7H</b></td> <td>Cipria <b>CP4J</b></td> </tr> <tr> <td>Rosa bubble <b>RB7Y</b></td> <td>Giallo zafferano <b>GZ8A</b></td> <td>Corallo <b>CR5T</b></td> <td></td> <td></td> <td></td> <td></td> </tr> </table>							Bianco opaco <b>BI7A</b>	Desert <b>DS9L</b>	Canapa <b>CN1X</b>	Moka <b>MK6B</b>	Grigio Dorian <b>GL4R</b>	Basalto <b>BS5T</b>	Grigio titanio <b>GZ8T</b>	Domy <b>DM7P</b>	Agave <b>GV7A</b>	Verde Alpi <b>VA5T</b>	Cadaques <b>CQ3Q</b>	Blu indaco <b>BI4B</b>	Blu opale <b>BO7H</b>	Cipria <b>CP4J</b>	Rosa bubble <b>RB7Y</b>	Giallo zafferano <b>GZ8A</b>	Corallo <b>CR5T</b>											
Bianco opaco <b>BI7A</b>	Desert <b>DS9L</b>	Canapa <b>CN1X</b>	Moka <b>MK6B</b>	Grigio Dorian <b>GL4R</b>	Basalto <b>BS5T</b>	Grigio titanio <b>GZ8T</b>																														
Domy <b>DM7P</b>	Agave <b>GV7A</b>	Verde Alpi <b>VA5T</b>	Cadaques <b>CQ3Q</b>	Blu indaco <b>BI4B</b>	Blu opale <b>BO7H</b>	Cipria <b>CP4J</b>																														
Rosa bubble <b>RB7Y</b>	Giallo zafferano <b>GZ8A</b>	Corallo <b>CR5T</b>																																		
		<table border="1"> <tr> <td>Trasparente <b>TR9M</b></td> <td>Trasparente fumé <b>FT8P</b></td> <td>Stop-sol <b>ST6P</b></td> <td>Specchio <b>SP7L</b></td> <td></td> <td></td> <td></td> </tr> </table>							Trasparente <b>TR9M</b>	Trasparente fumé <b>FT8P</b>	Stop-sol <b>ST6P</b>	Specchio <b>SP7L</b>																								
Trasparente <b>TR9M</b>	Trasparente fumé <b>FT8P</b>	Stop-sol <b>ST6P</b>	Specchio <b>SP7L</b>																																	
		<p>Specify the color of the aluminum frame</p> <table border="1"> <tr> <td>Alluminio <b>AL1A</b></td> <td>Titan grey <b>TG7H</b></td> <td></td> <td></td> <td></td> <td></td> <td></td> </tr> </table>							Alluminio <b>AL1A</b>	Titan grey <b>TG7H</b>																										
Alluminio <b>AL1A</b>	Titan grey <b>TG7H</b>																																			
		<table border="1"> <tr> <td>Trasparente <b>TR9M</b></td> <td>Trasparente fumé <b>FT8P</b></td> <td>Stop-sol <b>ST6P</b></td> <td>Specchio <b>SP7L</b></td> <td></td> <td></td> <td></td> </tr> </table>							Trasparente <b>TR9M</b>	Trasparente fumé <b>FT8P</b>	Stop-sol <b>ST6P</b>	Specchio <b>SP7L</b>																								
Trasparente <b>TR9M</b>	Trasparente fumé <b>FT8P</b>	Stop-sol <b>ST6P</b>	Specchio <b>SP7L</b>																																	
		<table border="1"> <tr> <td>Alluminio <b>AL1A</b></td> <td>Titan grey <b>TG7H</b></td> <td></td> <td></td> <td></td> <td></td> <td></td> </tr> </table>							Alluminio <b>AL1A</b>	Titan grey <b>TG7H</b>																										
Alluminio <b>AL1A</b>	Titan grey <b>TG7H</b>																																			
		<table border="1"> <tr> <td>Trasparente <b>TR9M</b></td> <td>Trasparente fumé <b>FT8P</b></td> <td>Stop-sol <b>ST6P</b></td> <td>Specchio <b>SP7L</b></td> <td></td> <td></td> <td></td> </tr> </table>							Trasparente <b>TR9M</b>	Trasparente fumé <b>FT8P</b>	Stop-sol <b>ST6P</b>	Specchio <b>SP7L</b>																								
Trasparente <b>TR9M</b>	Trasparente fumé <b>FT8P</b>	Stop-sol <b>ST6P</b>	Specchio <b>SP7L</b>																																	
		<table border="1"> <tr> <td>Alluminio <b>AL1A</b></td> <td>Titan grey <b>TG7H</b></td> <td></td> <td></td> <td></td> <td></td> <td></td> </tr> </table>							Alluminio <b>AL1A</b>	Titan grey <b>TG7H</b>																										
Alluminio <b>AL1A</b>	Titan grey <b>TG7H</b>																																			

Hotel - Contract markets - Home office

BASIC continuous headboards profile 3 x 5	690
SUPERIOR continuous headboards profile 7 x 5	691
Continuous headboards	692
MUSHY continuous headboard	693
Beds	694
STICK bedside tables Dpt 45.8	696
PODIO bench Dpt 49 - Ht 8	697
Bench Dpt 41 - Ht 10	697
Wardrobes Dpt 56.3	698
Suitcase holder	700
STICK suitcase holder	701
Mini-bar cabinets and writing desks with unfinished back panel	702
PODIO desks and shelves	704
Home office - technical information	706
Home office - Modular units Dpt 45	708
Home office - Desks	710

All measurements are expressed in centimeters; with tolerance ± 2 cm for upholstered items.

# BASIC continuous headboards profile 3 x 5

# SUPERIOR continuous headboards profile 7 x 5

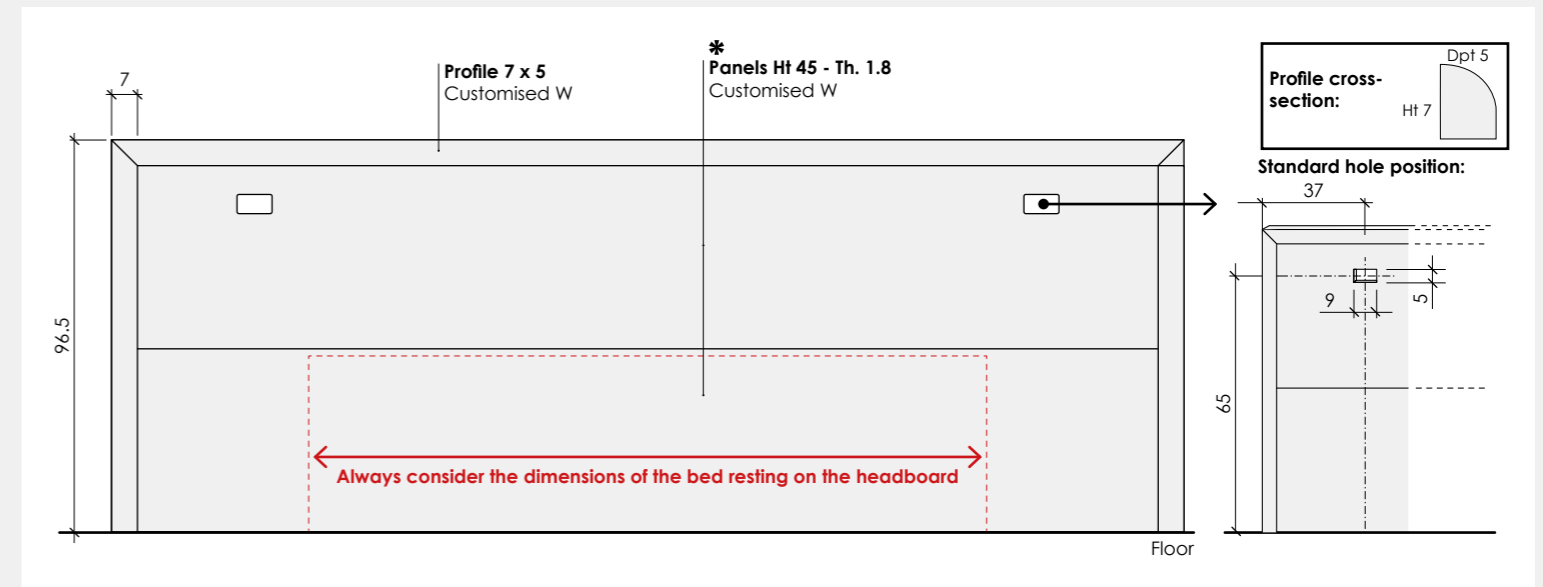
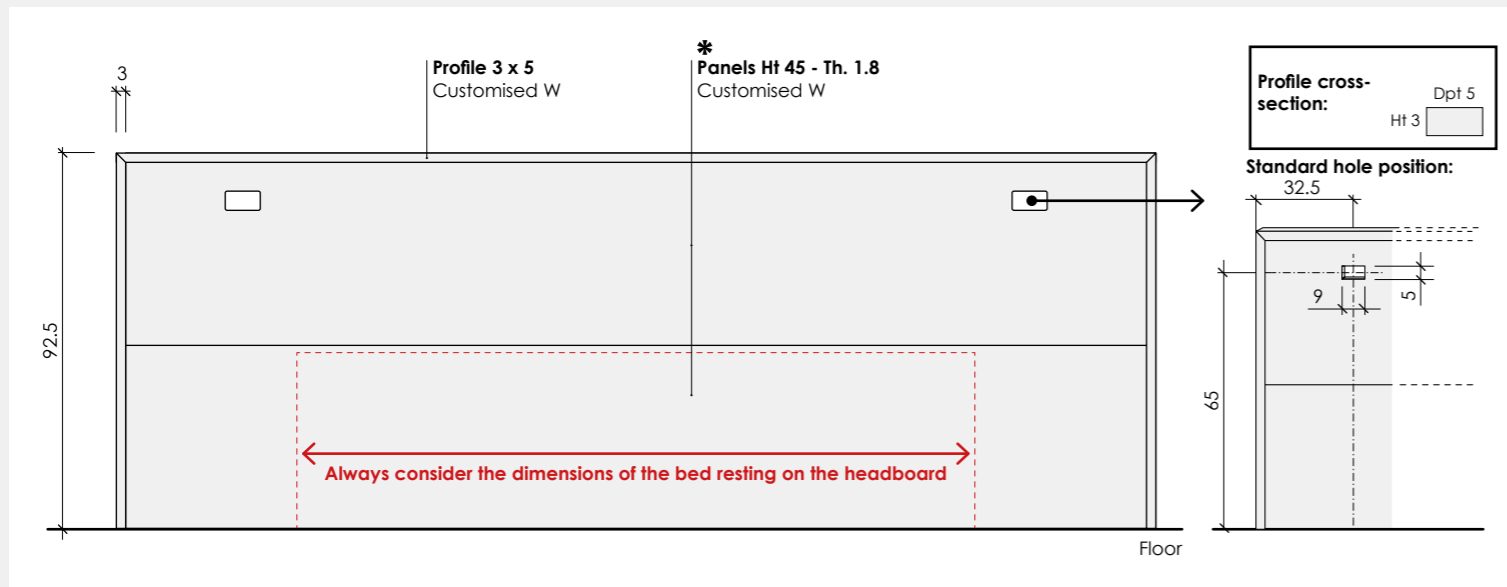

**Customised W**  
min 60.5  
max 255

Without holes  
Ht 92.5

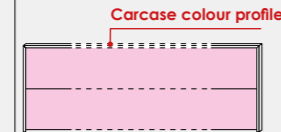

**Code** PK90.00M

ONE matte  
glossy

With holes 9x5  
Ht 92.5

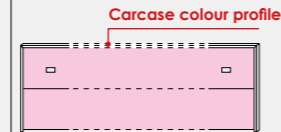

**Code** PK90.01T

**Customised W**  
min 256  
max 360

Without holes  
Ht 92.5

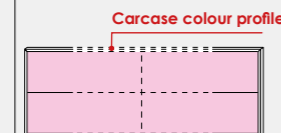

**Code** PK90.02Z

ONE matte  
glossy

With holes 9x5  
Ht 92.5

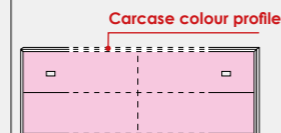

**Code** PK90.03F

## BASIC and SUPERIOR continuous headboard pillow

Complete with fixing Velcro, can be removed and washed.

Padding material:  
Flexible polyurethane, density 30 kg/m3.

W 85 - Ht 45 - Dpt 5

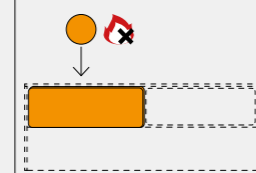

**Code** PL57.37T

□ Components in **CARCASE colors**

■ Components in **Types and colors FRONT**

● FAUX LEATHER 0100 0102 0600 0607

✘ Products made with CLASS 1 flame retardant components.

\* The 2 panels which make up the headboard have the shapes and finishes described in the "ONE fronts" section.

**Customised W**  
min 69  
max 265

Without holes

in 2 bands  
Ht 96.5



**Code** PK90.04N

ONE matte  
glossy

in 3 bands  
Ht 141.5

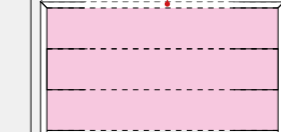

**Code** PK90.05U

in 4 bands  
Ht 186.5



**Code** PK90.06A

**Customised W**  
min 69  
max 265

With holes 9x5

in 2 bands  
Ht 96.5

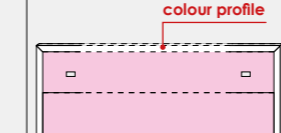

**Code** PK90.07G

ONE matte  
glossy

in 3 bands  
Ht 141.5

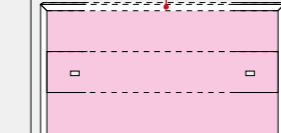

**Code** PK90.08P

in 4 bands  
Ht 186.5



**Code** PK90.09V

**Customised W**  
min 266  
max 360

Without holes

in 2 bands  
Ht 96.5

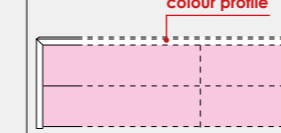

**Code** PK90.10S

ONE matte  
glossy

in 3 bands  
Ht 141.5

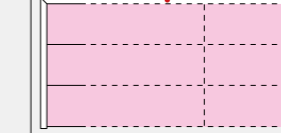

**Code** PK90.11Y

in 4 bands  
Ht 186.5

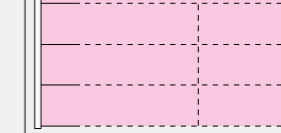

**Code** PK90.12E

**Customised W**  
min 266  
max 360

With holes 9x5

in 2 bands  
Ht 96.5



**Code** PK90.13M

ONE matte  
glossy

in 3 bands  
Ht 141.5



**Code** PK90.14T

in 4 bands  
Ht 186.5



**Code** PK90.15Z

# Continuous headboards

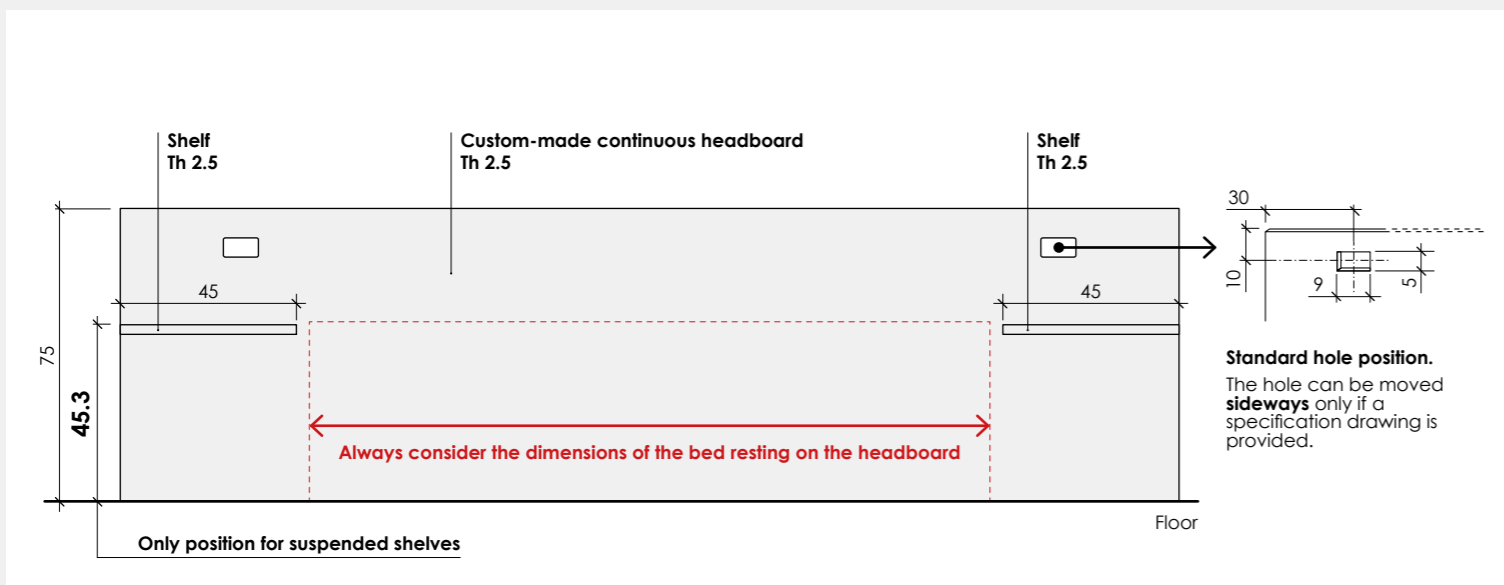

# MUSHY continuous headboard

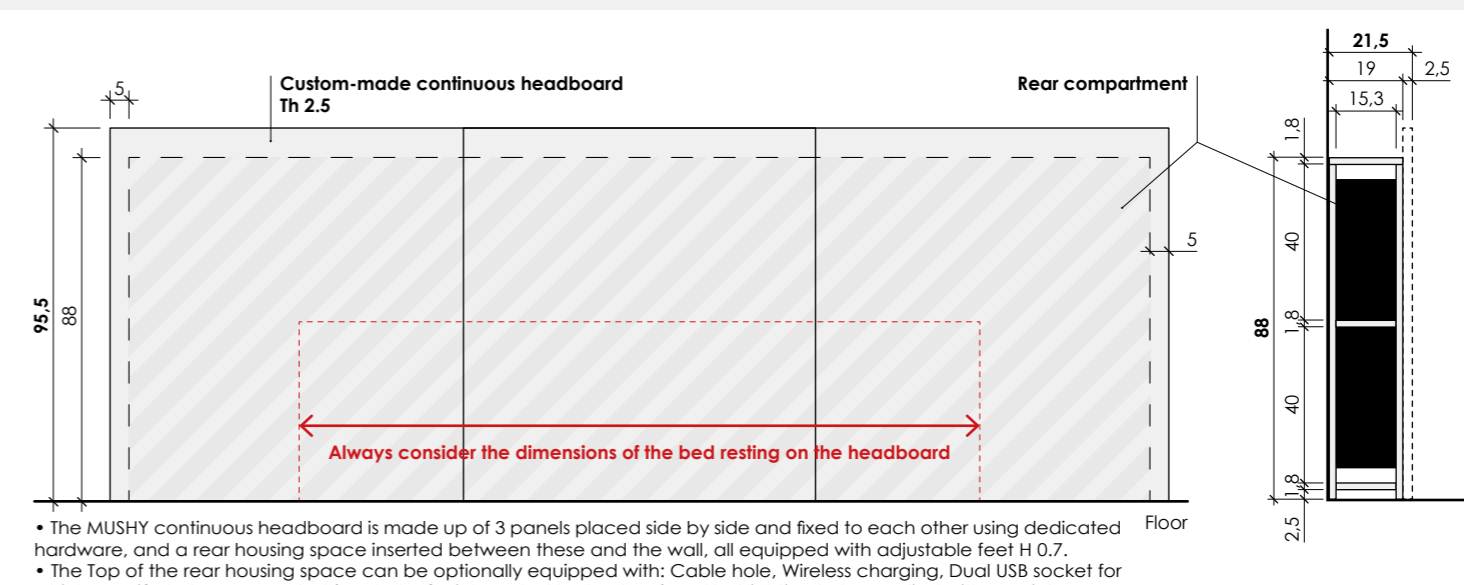

- The MUSHY continuous headboard is made up of 3 panels placed side by side and fixed to each other using dedicated hardware, and a rear housing space inserted between these and the wall, all equipped with adjustable feet H 0.7.
- The Top of the rear housing space can be optionally equipped with: Cable hole, Wireless charging, Dual USB socket for which specific holes are needed (see holes for integrated technology) and led lighting to be applied with special screws.

## Holes for built-in technology drilled by us on customer request

The rear housing space can be optionally equipped with integrated accessories (Cable hole, Wireless charging, Dual USB socket) for which specific holes need to be made on the top. One or more accessories can be selected. Following are the methods used to make the holes.

In metal + 15,00

In ABS + 9,00

+ 165,00

+ 100,00

**A** Cable hole

**B** Wireless charging

**C** Dual USB socket

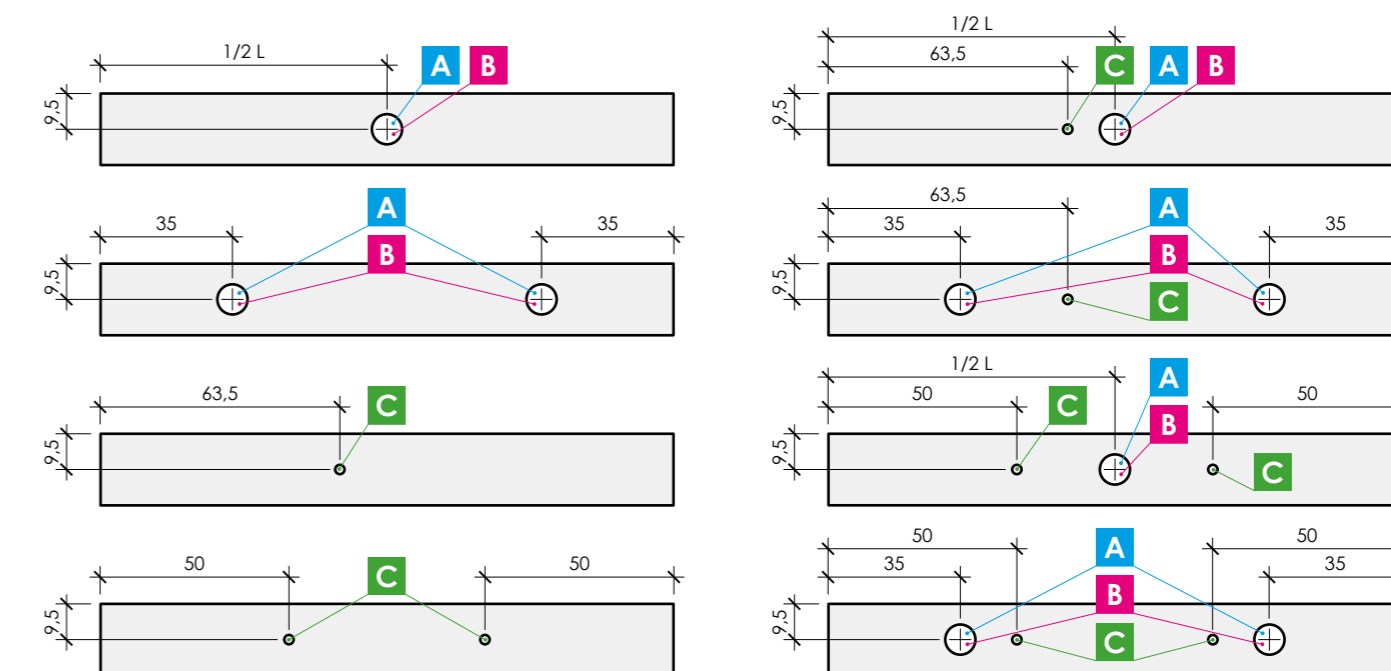

## Ht 75 - Th 2.5 Customised W min 30 max 360

Complete with wall mounting hardware.

	Plain	Plain with holes 9x5
Code	P46.28V	P46.30F
	0,35/cm + 129,00	0,35/cm + 129,00

## Ht 75 - Th 2.5 Customised W min 90 max 360

Complete with wall mounting hardware.

	With 2 shelves Dpt 28.5	With 2 shelves and 9x5 holes Dpt 28.5	Shelf W 45 - Dpt 26 - Th 2.5
Code	P68.94Q	P68.96A	P68.98M

### MUSHY

Base element, without holes for integrated technology

Ht 95.5

Dpt 21.5

W Max 310 Min 156



Code PK90.16F

### Led lighting kit

Lamp in black coloured aluminium with front veil to reduce glare. K4000 natural light, right-hand side touch power-on, 24 V 240 led/metre, 20 Watt/metre, CE. Complete power kit and fastening screws.

Custom-made Max 220 cm Min 140 cm



Code PK51.95K

<sup>1</sup> Wireless charging: Qi wireless charging standard

<sup>2</sup> Dual USB socket: Output: 5V DC - 2,10A Max. (1 x 2,10A) (2 x 1,05A)

- Components in **CARCASE** colors
- Components in **GROUP 2** colors
- Components in **GROUP 3** colors

# Beds

**Without base**  
Placed against  
continuous headboards  
**Modular beds**  
(bed base aligned with side)

ELFO

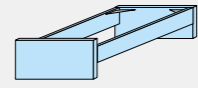

**SOAVE**  
Padded beds complete with bed  
base. Covers can be removed.  
Padding material:  
Flexible polyurethane, density 25  
kg/m³. Flame resistant material.  
The W 80 mattress can also be  
used.

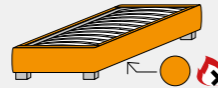

**KANT**  
Padded beds complete with bed  
base. Covers can be removed.  
Padding material:  
Flexible polyurethane, density 35  
kg/m³. Flame resistant material.

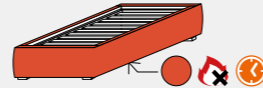

bed base W	Code	internal dimensions	Code	internal dimensions	Code	internal dimensions
75 x 190	-	-	PL57.43X	192 x 76	-	-
80 x 190	PL57.40C	191 x 81,5	-	-	-	-
90 x 190	PL57.41K	191 x 91,5	-	-	PL57.17G	195 x 92
120 x 190	-	-	-	-	PL57.18P	195 x 122
160 x 190	-	-	PL57.44D	193 x 162	PL57.19V	195 x 162

**Without base**  
Placed against  
continuous headboards

ELFO

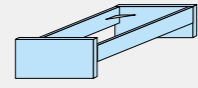

**NORMALE**  
Ht 46  
Dpt 197  
207  
W 90  
100  
129  
170  
190

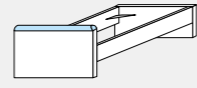

**ATLANTE**  
Ht 47  
Dpt 197  
207  
W 90  
-  
-  
171  
-

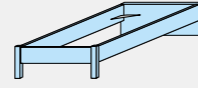

**GIOVE**  
Ht 34  
Dpt 199,5  
209,5  
W 90  
100  
129  
170  
190

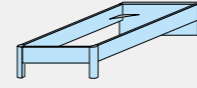

**MARTE**  
Ht 34  
Dpt 199,5  
209,5  
W 90  
100  
129  
170  
190

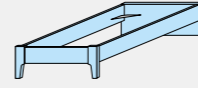

**NETTUNO**  
Ht 34  
Dpt 199,5  
209,5  
W 90  
100  
129  
170  
190

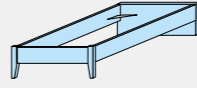

**METAL BED FRAME**  
Complete with slatted base  
and 4 feet.  
Ht 29  
Dpt 193  
-  
W 88  
98  
128  
168  
-

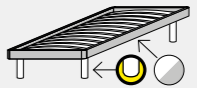

bed base W	Code	internal dimensions	Code	internal dimensions	Code	internal dimensions	Code	internal dimensions	Code	internal dimensions	Code	internal dimensions
80 x 190	P46.26KP	191 x 81,5	P46.56XP	191 x 81,5	P46.61Z	192,5 x 81,5	PL49.86U	192,5 x 81,5	PL57.54K	192,5 x 81,5	PL57.59S	192,5 x 81,5
90 x 190	P68.91YP	191 x 91,5	-	-	PL57.46S	192,5 x 91,5	PL57.50H	192,5 x 91,5	PL57.55R	192,5 x 91,5	PL57.60P	192,5 x 91,5
		201 x 91,5	-	-		202,5 x 91,5		202,5 x 91,5		202,5 x 91,5		202,5 x 91,5
120 x 190	PL57.45L	191 x 121	-	-	PL57.47Y	192,5 x 121	PL57.51Q	192,5 x 121	PL57.56X	192,5 x 121	PL57.61V	192,5 x 121
		201 x 121	-	-		202,5 x 121		202,5 x 121		202,5 x 121		202,5 x 121
160 x 190	P68.92DP	191 x 161,5	P68.93KP	191 x 161,5	PL57.48E	192,5 x 161,5	PL57.52W	192,5 x 161,5	PL57.57D	192,5 x 161,5	PL57.62B	192,5 x 161,5
		201 x 161,5		201 x 161,5		202,5 x 161,5		202,5 x 161,5		202,5 x 161,5		202,5 x 161,5
180 x 200	PL57.73P	201 x 181,5	-	-	PL57.74V	202,5 x 181,5	PL57.75B	202,5 x 181,5	PL57.76H	202,5 x 181,5	PL57.77Q	202,5 x 181,5
Custom-made beds Max W 205	P92.25BP	-	-	-	PL57.49M	-	PL57.53C	-	PL57.58L	-	PL57.63H	-

per cm fixed charge

**SOAVE**  
Faux leather covers

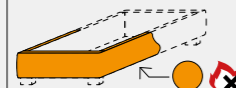

**KANT**  
Microfiber covers

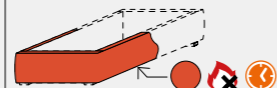

For beds W:	Code	Code
75	PL57.70U	-
80	-	-
90	-	PL57.67K
120	-	PL57.68R
160	PL57.71A	PL57.69X

**Faux leather**  
custom sized

Ht 140

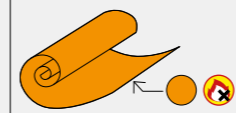

Code	PL57.72G	PL57.64Q
------	----------	----------

**Bolster**

Covers can be removed  
Padding material:  
Flexible polyurethane, density 25 kg/m³.

W 80

Ø 18

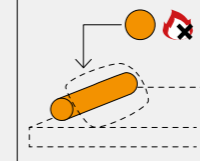

- Components in **CARCASE** colors
- Components in **GROUP 2** colors
- FAUX LEATHER MIAMI FIRE: 0100, 0102, 0600, 0607
- MICROFIBER ECOCHIC: Z66H, Z67M, Z68Q, Z69T, Z70R, Z71U

- Fireproof 1 CLASS
- Products made with CLASS 1 flame retardant components.
- Delivery approximately 4 weeks from order receipt.
- BI7A, AL1A

- RW3Q, RD5T, CL1X, BI7A, AL1A, TR8A

\* When ordering, it is essential to state the width and depth of base. Base to be supplied by the customer.



When ordering, specify for bed base D 190 or 200.



## STICK bedside tables Dpt 45.8



- Top and side panels Th 2.5.
- Drawers Th 1.8.
- Provided with "Quadro" type metal slides which have adjustable height and soft-close system. Drawers internal color CHARM.
- Ht 0.7 adjustable feet.

Handles available:

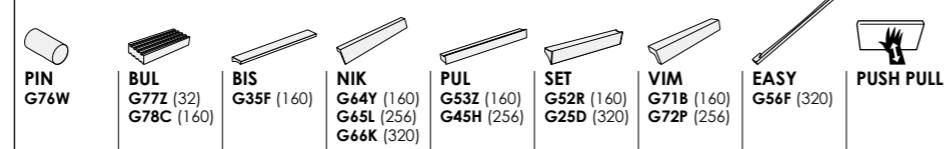

Ht 41,7  
W 53,7  
With 1 drawer  
Ht 24 and  
1 Ht 12

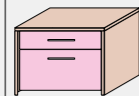

Code **PK51.67F**

ONE matte  
glossy

Ht 41,7  
W 53,7  
with small drawer  
Ht 12

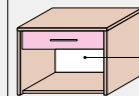

Code **PK51.66Z**

Back panel in CHARM finish

Code	<b>PK51.67F</b>	<b>PK51.66Z</b>				
ONE	<u>matte</u> glossy					

With fixed intermediate shelf

Ht 41,7  
W 53,7

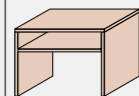

Code **PK51.65T**

With glass movable shelf

Ht 41,7  
W 53,7

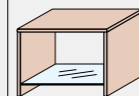

Code **PK51.64M**

Glass shelf Th 0.8  
For bedside table PK51.64M

Dpt 41,8  
W 48



Code **P93.90H**

Code	<b>PK51.65T</b>	<b>PK51.64M</b>	<b>P93.90H</b>			
------	-----------------	-----------------	----------------	--	--	--

Components in **GROUP 2 colors**  
Components in **GROUP 3 colors**  
Components in **Types and colors FRONT**



## PODIO bench Dpt 49 - Ht 8

- With adjustable feet.
- Element can not be modified.
- Finishes are on 3 sides (needs positioning against the wall).

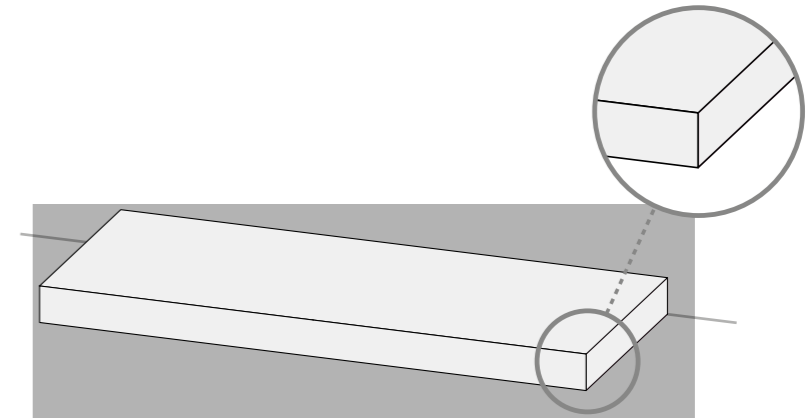

	90	120	150		
Code	<b>PL48.84B</b>	<b>PL48.85H</b>	<b>PL48.86Q</b>		

Back panels

Wall fixing with the provided hardware.

Ht 27,5  
Th 1,8

	90	120	150		
Code	<b>PL48.81G</b>	<b>PL48.82P</b>	<b>PL48.83V</b>		

## Bench Dpt 41 - Ht 10

- Top and structure made with Th 1.8 panels.
- With adjustable feet.
- Element can not be modified.
- Finishes are on all of the four sides (it can be placed in any position).
- You can use Modular self standing elements D 45 or 32.5.

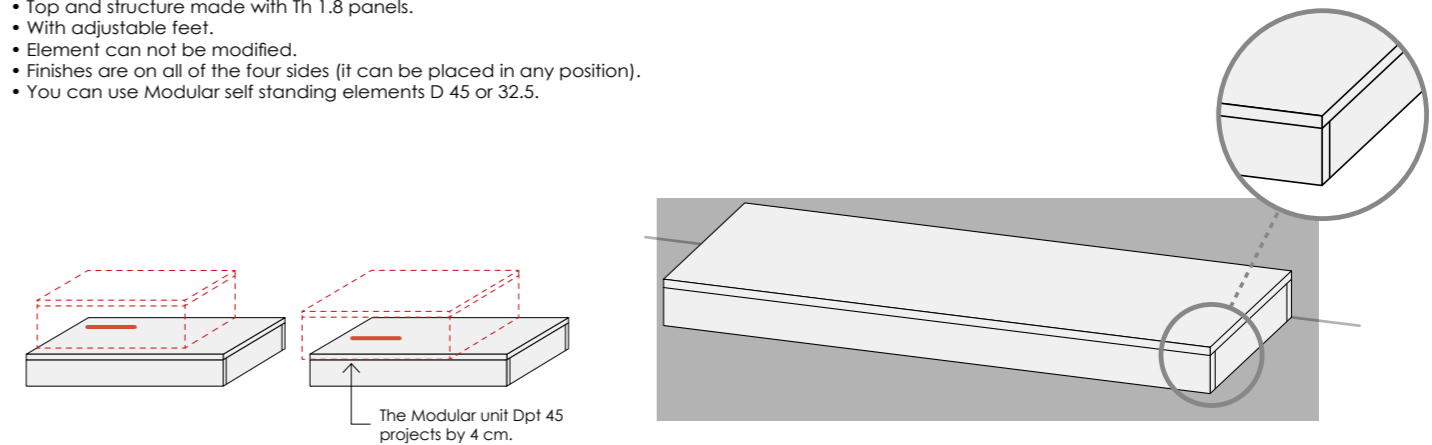

	45	60	90	120	
Code	<b>P78.97H</b>	<b>P78.98P</b>	<b>P78.99U</b>	<b>P78.49X</b>	

# Wardrobes Dpt 56.3

## W 45

Open with luggage rack and clothes-hanging bar

<b>Code</b>	<b>PK90.20X</b>	<b>PK90.21D</b>	<b>PK90.55W</b>	<b>PK90.22L</b>					
-------------	-----------------	-----------------	-----------------	-----------------	--	--	--	--	--

## W 60

Open with luggage rack and clothes-hanging bar

<b>Code</b>	<b>PK90.23S</b>	<b>PK90.24Y</b>	<b>PK90.56C</b>	<b>PK90.25E</b>	<b>PK90.32R</b>	<b>PK90.33X</b>	<b>PK90.37Y</b>	<b>PK90.38E</b>	
-------------	-----------------	-----------------	-----------------	-----------------	-----------------	-----------------	-----------------	-----------------	--

## W 90

Open with luggage rack and clothes-hanging bar

<b>Code</b>	<b>PK90.26M</b>	<b>PK90.27T</b>	<b>PK90.57K</b>	<b>PK90.28Z</b>	<b>PK90.34D</b>	<b>PK90.35L</b>	<b>PK90.39M</b>	<b>PK90.40H</b>	
-------------	-----------------	-----------------	-----------------	-----------------	-----------------	-----------------	-----------------	-----------------	--

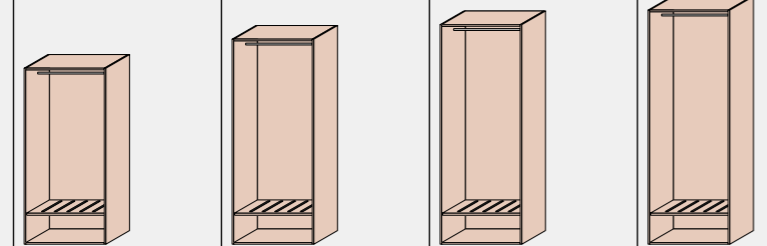
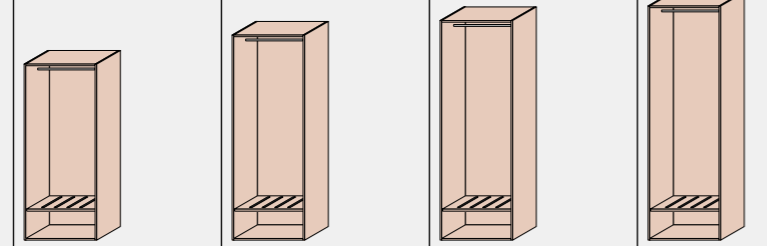
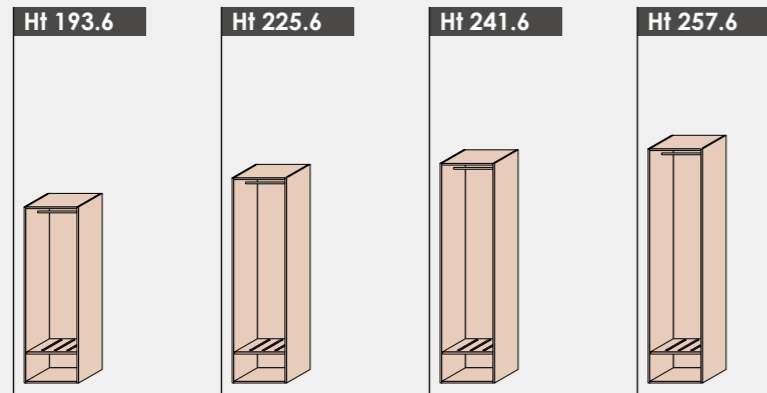

### Housing space W 56.3 for safe

Complete with door with side grip.  
Ht 34,5  
Dpt 51,5

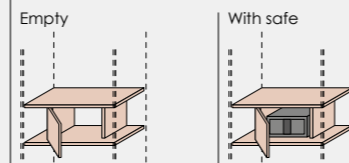

**PK90.32R**   **PK90.33X**

### Housing space W 56.3 for mini-bar

Complete with ventilation grille.  
Ht 66,5  
Dpt 51,5

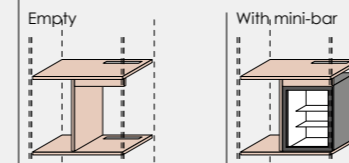

**PK90.37Y**   **PK90.38E**

### Housing space W 86.3 for safe

Complete with door with side grip.  
Ht 34,5  
Dpt 51,5

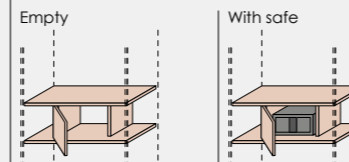

**PK90.34D**   **PK90.35L**

### Housing space W 86.3 for mini-bar

Complete with ventilation grille.  
Ht 66,5  
Dpt 51,5

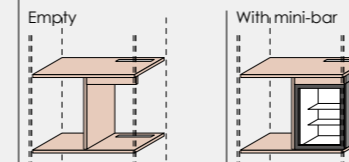

**PK90.39M**   **PK90.40H**

### Examples of wardrobes with housing space for safe and mini-bar

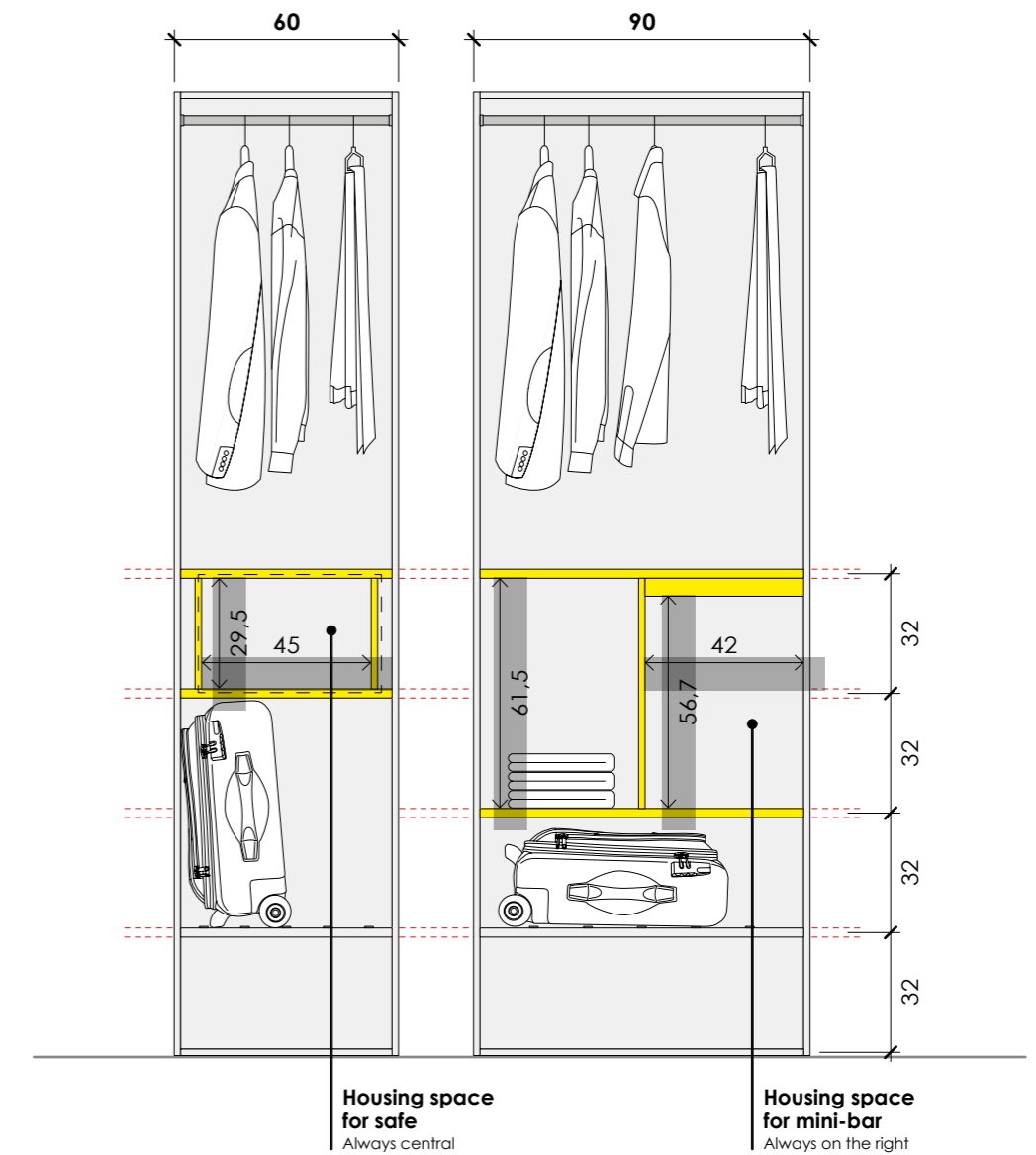

### Movable shelves

Th 2,5  
Dpt 51,5

W 41,3   W 56,3   W 86,3



<b>Code</b>	<b>PK90.29F</b>	<b>PK90.30C</b>	<b>PK90.31K</b>
-------------	-----------------	-----------------	-----------------

### Safe

Motorized lock  
6-digit led display  
Internal led light  
Master-user password  
Anthracite color  
Net weight 13 Kg.

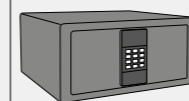

Ht 20  
Dpt 37  
W 42

**PK90.36S**

### Mini-bar (for built-in installation)

Capacity 40 litres  
Weight 19.5 kg.  
Power supply voltage 230 V  
Internal led light

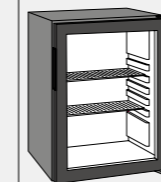

Ht 56  
Dpt 44,5  
W 40,2

**PK90.41Q**

Components in **GROUP 3 colors**

\* Price of the element in **GROUP 3 colors** (CARCASE colors excluded)



**OPTIONAL:** p. 86  
A · Extra colors for Top panel, Bottom panel and Shelves  
B · Extra colors for Side panels  
C · Increased Back panel Th 0.8  
D · PLUS clothes-hanging bar



p. 44 Filler strips  
p. 132 Accessories for Wardrobe Dpt 56.3

# Suitcase holder

- Structure Th 1.8 complete with top Th 2.5.
- Side panels equipped with furniture pads (option to mount Feet: DELTA, NUME, EPSILON, TWIG).

	Ht 35 Dpt 57,1 W 90	Ht 45,5 Dpt 59 W 90	
	↓ 10 scratch-guard strips	↓ 10 scratch-guard strips	
<b>Code</b>	<b>PK90.42W</b>	<b>PK90.43C</b>	

	Ht 35 Dpt 45,8 W 90	Ht 45,5 Dpt 47,6 W 90	
	↓ 10 scratch-guard strips	↓ 10 scratch-guard strips	
<b>Code</b>	<b>PK90.44K</b>	<b>PK90.45R</b>	

## Feet usable

Adjustable feet - Pack of 4

	<b>DELTA</b> Ht 11	<b>NUME</b> Ht 11	<b>EPSILON</b> Ht 15,5	<b>TWIG</b> Ht 16	
<b>Code</b>	<b>P07.60P</b>	<b>PK50.00Y</b>	<b>P08.37S</b>	<b>PK50.01E</b>	

## Scratch-guard plastic strips

With biadhesive tape.

Pack of 5.  
For suitcase holder  
Dpt 57.1



Pack of 5.  
For suitcase holder  
Dpt 45.8



<b>Code</b>	<b>P51.79H</b>	<b>P13.99Q</b>		

- Components in **CARCASE** colors
  - Components in **GROUP 2** colors
  - Components in **GROUP 3** colors
  - B17A GZ8T GV7A CQ3Q B14B BO7H CP4J R87Y CR5T AL1A
  - AL1A GZ8T CH2M
  - Solid natural ash wood
- Wood is a natural product and, as such, is subject to variations in color and grain. Differences in grain or color therefore do not constitute grounds for dispute.

# STICK suitcase holder

	Ht 39,5 Dpt 57,1 W 90	Ht 90 Dpt 59 W 90	
	↓ 5 scratch-guard strips	↓ 5 scratch-guard strips	
<b>Code</b>	<b>PL48.87W</b>	<b>PL48.88C</b>	

	Ht 39,5 Dpt 45,8 W 90	Ht 90 Dpt 47,6 W 90	
	↓ 5 scratch-guard strips	↓ 5 scratch-guard strips	
<b>Code</b>	<b>PL48.89K</b>	<b>PL48.90F</b>	

## Scratch-guard aluminium strips

With biadhesive tape.

Pack of 5.  
For suitcase holder  
Dpt 57.1



Pack of 5.  
For suitcase holder  
Dpt 45.8

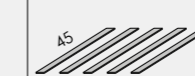

<b>Code</b>	<b>P13.97D</b>	<b>P13.98K</b>		

# Mini-bar cabinets and writing desks with unfinished back panel

- The doors are fitted with decelerated hinges.
- It is advisable to keep the desks with mini-bar and the refrigerator door units detached from the rear wall to facilitate cooling of the refrigerator.

## Ht 77.3 Dpt 45.8

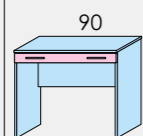

**P04.69C**

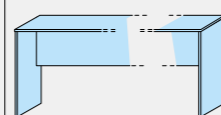

**P04.68X**

Custom-made  
Min 45 Max 220

<b>Code</b>	<b>P04.69C</b>	<b>P04.68X</b>							
ONE	matte								
	glossy								

## Ht 77.3 Dpt 57.1

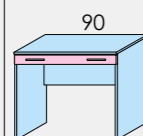

**P04.62Q**

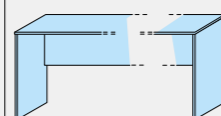

**P04.47H**

Custom made  
Min 45 Max 220

With mini-bar fridge  
**Specify R or L** (L in drawing)  
Custom made  
Min 90 Max 220

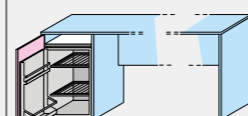

**PK90.46X**

With mini-bar fridge  
**Specify R or L** (L in drawing)  
Custom made  
Min 135 Max 220

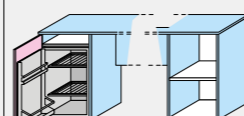

**PK90.47D**

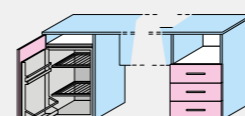

**PK90.52B**

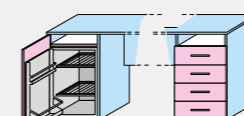

**PK90.53H**

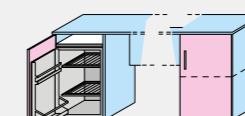

**PK90.54Q**

<b>Code</b>	<b>P04.62Q</b>	<b>P04.47H</b>	<b>PK90.46X</b>	<b>PK90.47D</b>	<b>PK90.52B</b>	<b>PK90.53H</b>	<b>PK90.54Q</b>		
ONE	matte								
	glossy								

## Mini-bar cabinet W 45

Empty without top  
**Specify R or L** (L in drawing)  
Ht 74.8

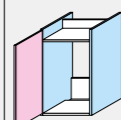

**PK90.48L**

With mini-bar cabinet without top  
**Specify R or L** (L in drawing)  
Ht 74.8

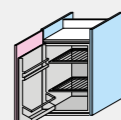

**PK90.49S**

Empty with top  
**Specify R or L** (L in drawing)  
Ht 77.3

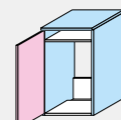

**PK90.50P**

With mini-bar cabinet with top  
**Specify R or L** (L in drawing)  
Ht 77.3

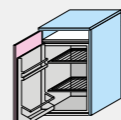

**PK90.51V**

<b>Code</b>	<b>PK90.48L</b>	<b>PK90.49S</b>	<b>PK90.50P</b>	<b>PK90.51V</b>					
ONE	matte								
	glossy								

## Mini-bar (for built-in installation)

Outside colour black.  
Capacity **40 litres**.  
Weight **13.5 kg**.  
Power supply voltage **220 V**.  
Interior **W 31.5 - Dpt 24 - Ht 45**.  
W 39 - Dpt 45 - Ht 54

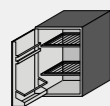

<b>Code</b>	<b>P38.56B</b>								
-------------	----------------	--	--	--	--	--	--	--	--

- Components in **CARCASE** colors
- Components in **GROUP 2** colors
- Components in **Types and colors FRONT**



**OPTIONAL:** **p. 409**  
**A** · Extra colors for Side panels Writing-desk block and Drawer units (for Mini-bar cabinets and writing desks blocks)  
**B** · Drawers and big drawers with soft-close



**p. 56** Knob and handle positions

# PODIO desks and shelves

- We recommend positioning the desk top at a maximum height of 77 cm from the floor.
- Adjustable support brackets for wall fixing are included.
- Maximum load recommended: 60 Kg.
- Element can not be modified.

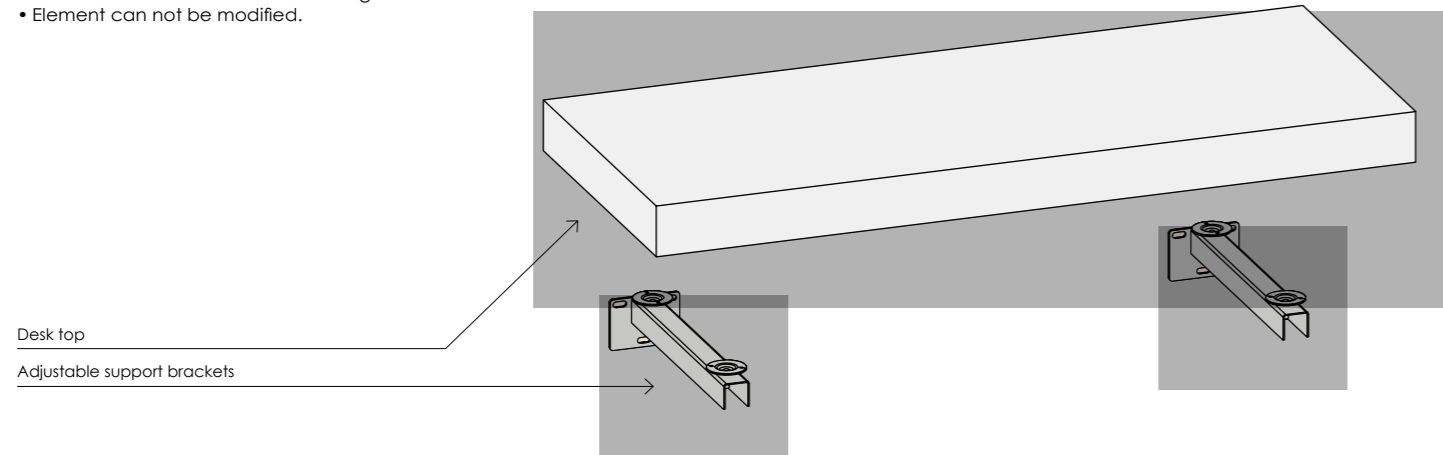

On request, the top can be fitted with the following built-in technology:



The holes required will be drilled in fixed positions.  
For details, see the chapter "Holes for built-in technology".

## PODIO desks

Ht 8  
Dpt 49

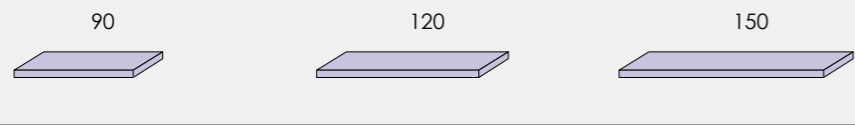

Code	PL48.95P	PL48.96V	PL48.97B	

## Back panel

Wall fixing with the provided hardware.

Ht 27,5  
Th 1,8

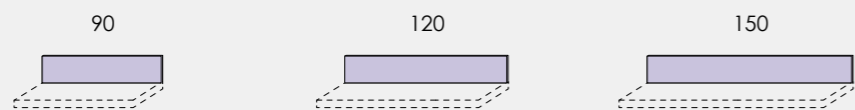

Code	PL48.81G	PL48.82P	PL48.83V	

## Shelves \*

With shelf holders  
INTEGRATED

Ht 5,5  
Dpt 24



Code	PL38.75Z <sup>2</sup>	PL38.76F <sup>3</sup>	PL38.77N <sup>3</sup>	

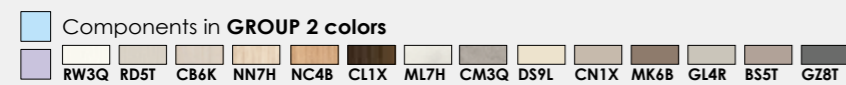

<sup>2</sup> Indicates the number of shelf holders supplied.

\* **Maximum recommended load (net of shelves): 30 kg for each pair of shelf holders.**  
N.B. for loads evenly distributed over the shelf.

# Home office - technical information

## Modular units Dpt 45

- Fitted with ALFA-16 adjustable feet H 1.6.
- They are units that can stand on the floor or on top of others units.
- Every unit is provided with 2 side panels perfectly aligned with top finishing insert and bottom parts.
- You must complete every composition with top. A composition of multiple units can share same top (W 360 max).
- The hardware is placed in a personalized fashion according to the position of the components.
- The sides have a continuous line of holes at a distance of 32 mm to allow the insertion of large document files.

Dimensions (not including top and feet):

**W** 45 - 60 - 90  
**Dpt** 45  
**Ht** 96 - 192

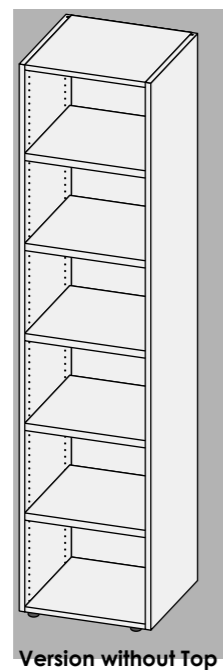
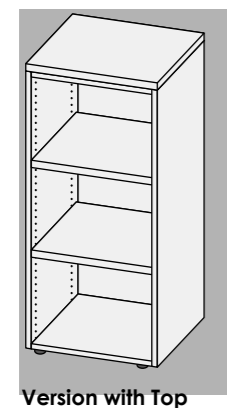
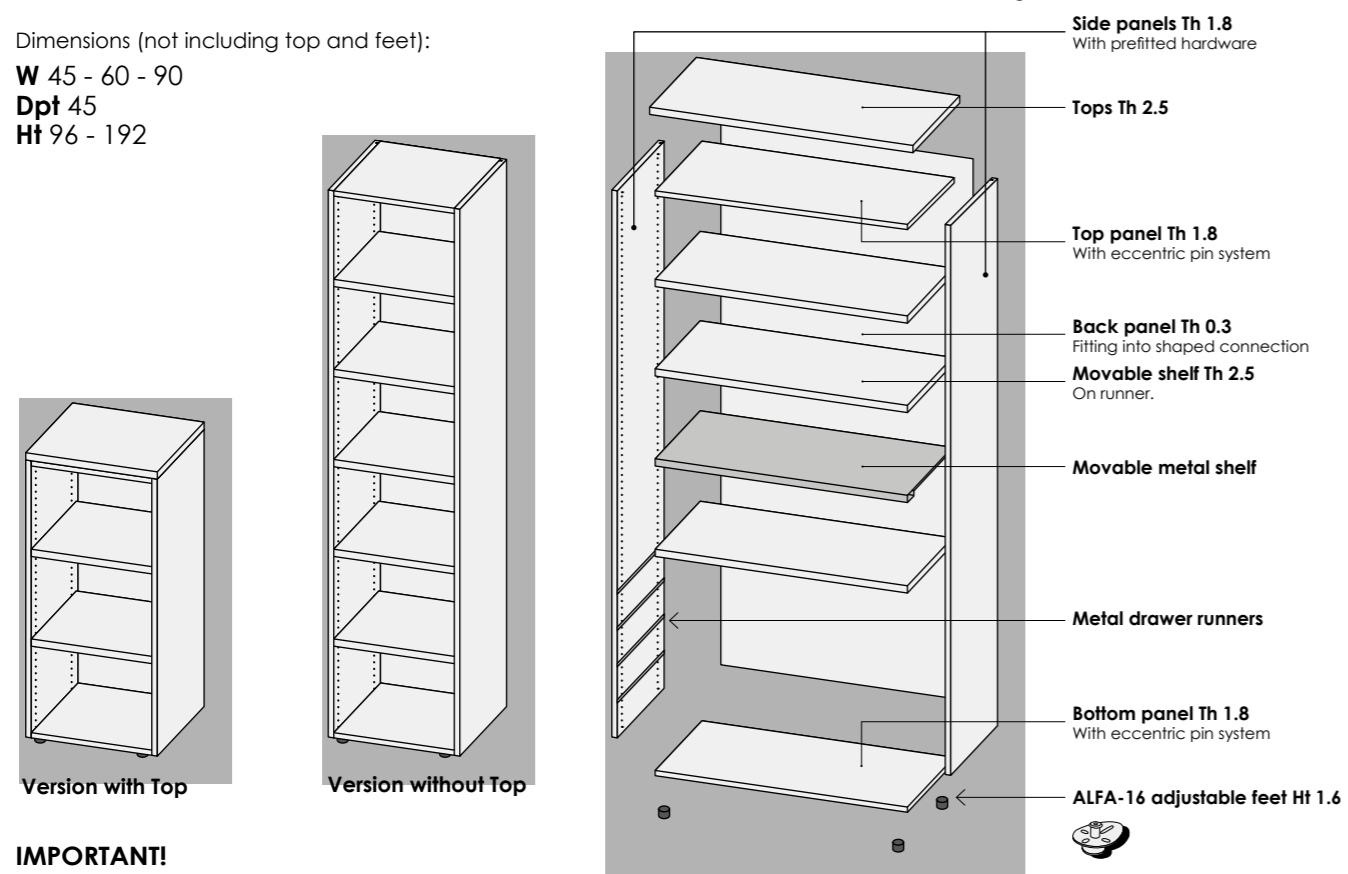

## IMPORTANT!

- The doors are fitted with decelerated hinges.
- The ONE fronts (swing, pull-up, pull-down doors, drawers and deep drawers) can be equipped with push-pull opening. Selecting a "push pull" handle will determine the need for "Quadro" type push pull runners on the drawers.
- The drawers and big drawer CLUB are always fitted with height-adjustable soft-close "Quadro" metal slides with interior CHARM finish.
- **Internal fittings supplied consist in:** Melamine-faced movable shelves as illustrated.
- **For custom cuts consult the relevant chapter.**
- In units W 90 with doors W 30 + W 60 the direction is determined by the position of the door W 60.
- Upon request, the doors can be supplied without a handle and without handle holes (not on CLUB and WINDOW).
- The Modular units with pairs of CLUB doors are provided with only one handle. In elements with doors W 30 + W 60 the handle is placed on the W 60 door. Upon customer's request the CLUB handle can be mounted on both doors.
- Shelves, top, bottom and back panels in carcase colours.

## Handles available for Modular units Dpt 45 and Drawer units on wheels:

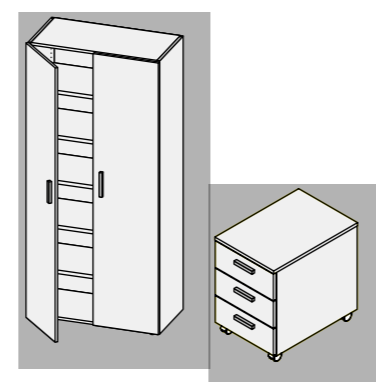
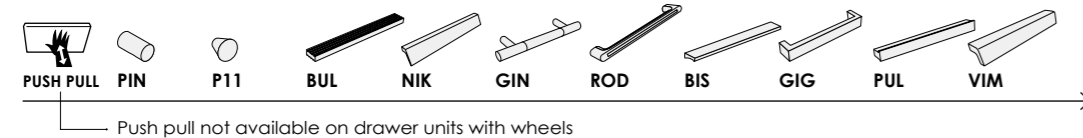

## Desks

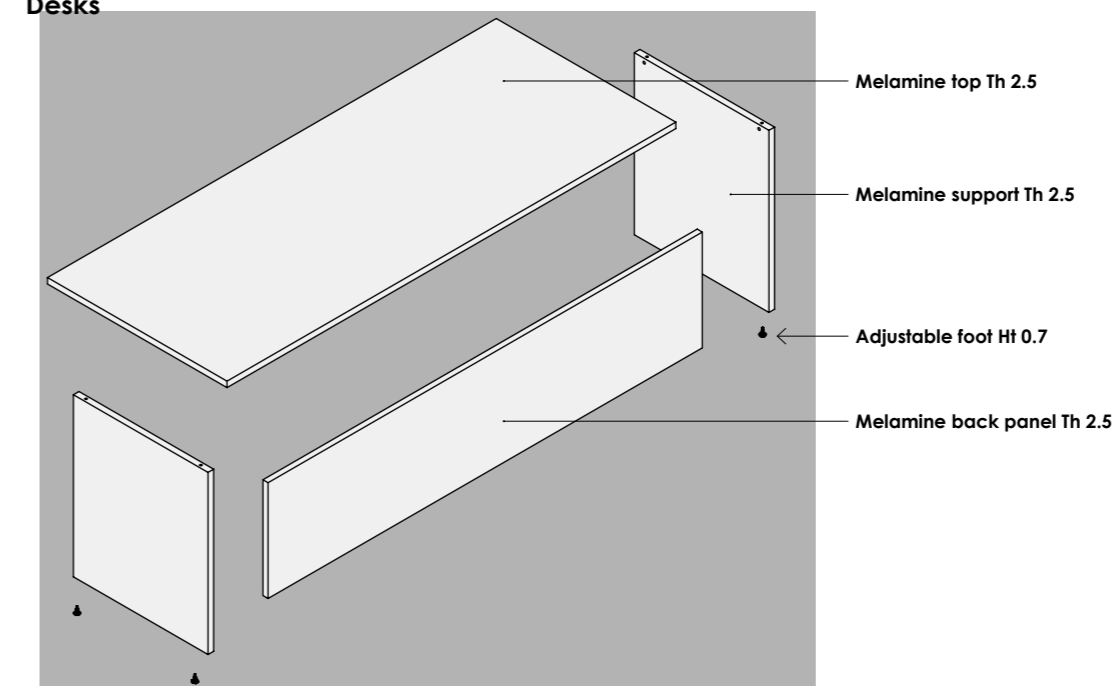

○ = Cable pass-through hole Ø 8. The holes will be made by us if you provide your own drawing. The minimum distance from the side is 15 cm for the straight-edged desk. The position of the hole for the workstation is as illustrated.

## Linear desk

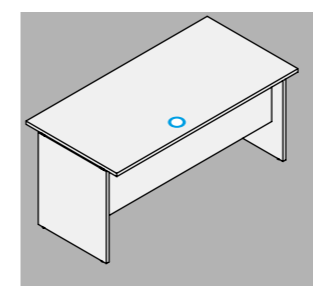
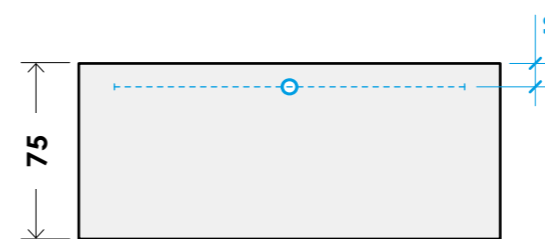

## Workstation with tubular support

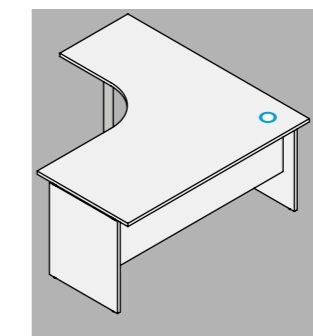
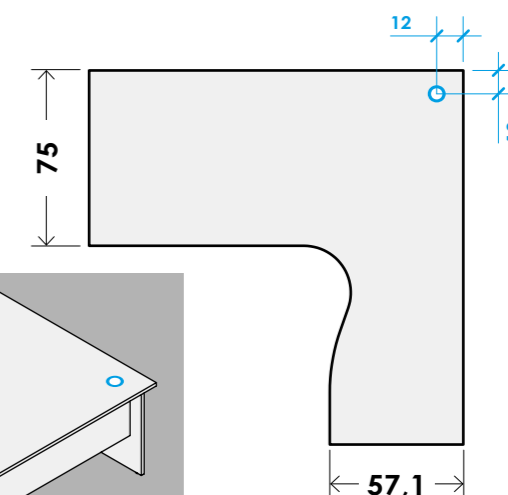



# Home office - Modular units Dpt 45

## W 45

Specify hinge  
R or L

Reference images →

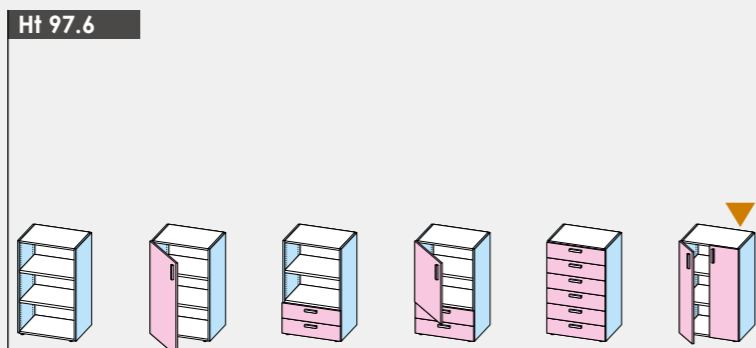

Code	PL27.01C	PL27.02K	PL27.03R	PL27.04X	PL27.05D	-													
ONE	matte																		
	glossy																		
CLUB																			
WINDOW																			

## W 60

Specify hinge  
R or L

Code	PL27.06L	PL27.07S	PL27.08Y	PL27.09E	PL27.10B	PL27.11H													
ONE	matte																		
	glossy																		
CLUB																			
WINDOW																			

## W 90

Reference images →

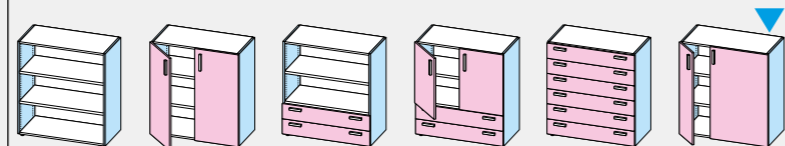

Code	PL27.12Q	PL27.13W	PL27.14C	PL27.15K	PL27.16R	PL27.17X													
ONE	matte																		
	glossy																		
CLUB																			
WINDOW																			

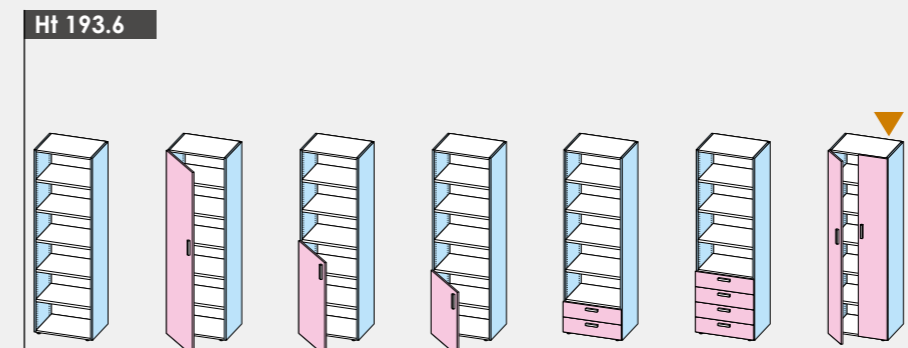

Code	PL27.21P	PL27.22V	PL27.23B	PL27.24H	PL27.25Q	PL27.26W	-												
ONE																			
CLUB																			
WINDOW																			

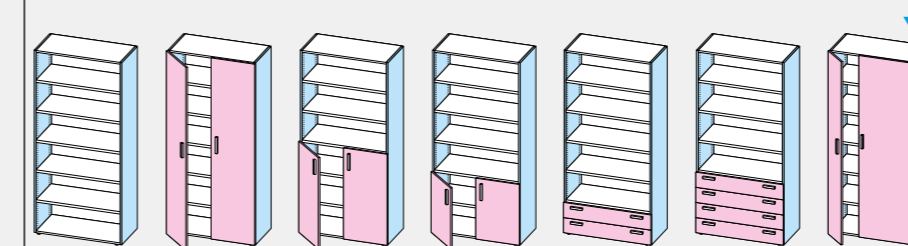

Code	PL27.27C	PL27.28K	PL27.29R	PL27.30N	PL27.31U	PL27.32A	PL27.33G												
ONE																			
CLUB																			
WINDOW																			

### Tops Th 2.5 - Dpt 45.8

Complete every composition Ht 97.6 with Top.  
The top is optional in the compositions of the Ht 193.6.

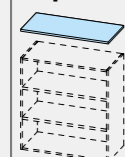

W	Code	W	Code
45	P77.17V	165	PK72.23U
60	P77.18A	180	P77.21S
90	P77.19F	225	P77.22X
105	PK72.21F	240	PK72.24A
120	PL76.01Q	270	P77.23C
135	P77.20M	Custom-made Max 360 Min 30	P77.24H
150	PK72.22N		

### Adjustable feet ALFA-16

Ht 1,6



Code	PK72.87C

### Movable shelf

Dpt 41.7 - Th 2.5

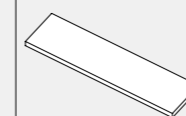

W	Code
45 (41.3)	P50.60B
60 (56.3)	P26.59K
90 (86.3)	P50.62N

### Movable metal shelf

Dpt 40 - Th 1.8

Cannot be used as dividing shelves for drawers and doors.  
Cannot be used for hanging files.

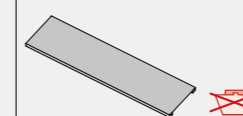

Code
P02.65Z
-
P02.66E

### Movable metal shelf

Dpt 40 - Th 2.5

Cannot be used as dividing shelves for drawers and doors.  
Used to hanging files.

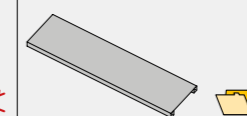

Code
P02.67L
-
P02.68R

### Pull-out file holder for unit with doors

Dpt 35.5 - Ht 10

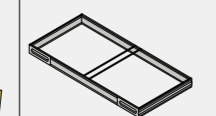

Code
P02.69W
-
P02.70B

### Diagram of layout of files on frame

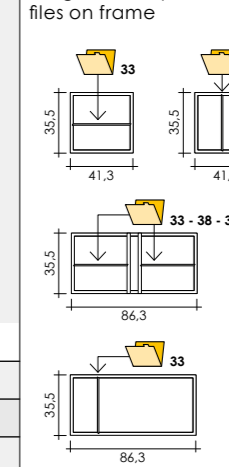

- Components in **CARCASE** colors
- Components in **GROUP 2** colors
- Components in **Types and colors FRONT**
- Aluminium colour components

- With doors W 30
- With doors W 30 + W 60 - Indicate R or L (drawing - R)



**OPTIONAL:** p. 614  
B - Extra colors for SIDE PANELS  
D - Drawers and big drawers with soft-close

**CLUB**  
drawers and big drawers  
CHARM with soft-close "Quadro"  
type slides as standard  
(without surcharges)

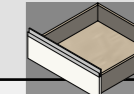

# Home office - Desks

## Linear desk

Ht 75

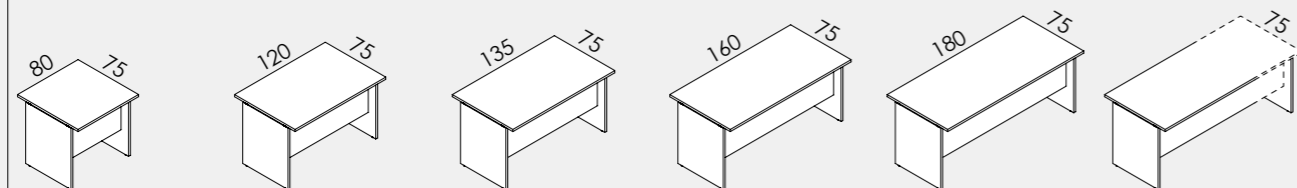

Code	PL27.51E	PL27.52M	PL27.53T	PL27.54Z	PL27.55F	PL27.56N
------	----------	----------	----------	----------	----------	----------

## Workstation with tubular support

Ht 75

with tubular support



Code	PL27.57U	PL27.58A
	448,00	448,00

## 90° connectable linear desk

Ht 75

with tubular support

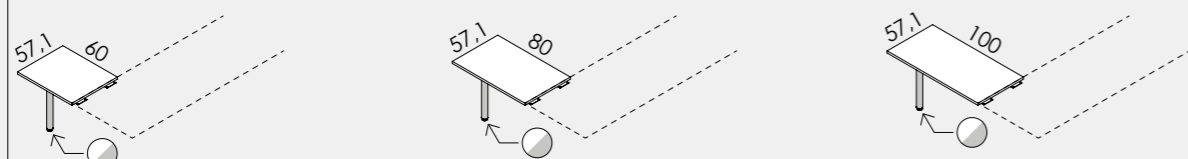

Code	PL27.59G	PL27.60D	PL27.61L
------	----------	----------	----------

## 90° shaped connection

Th 2.5

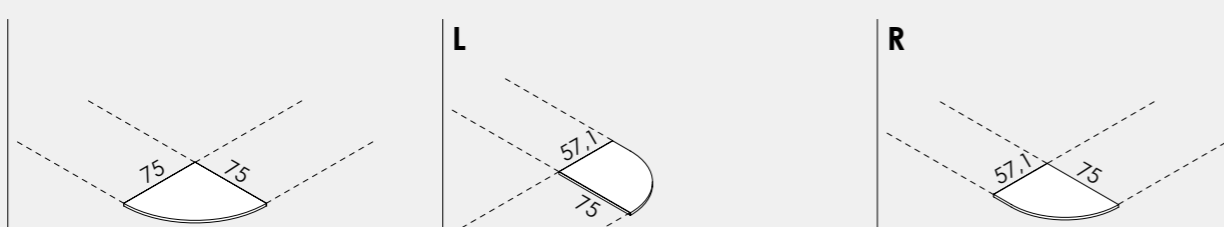

Code	PL27.62S	PL27.63Y	PL27.64E
------	----------	----------	----------

## 90° shaped connection

Ht 75

with tubular support

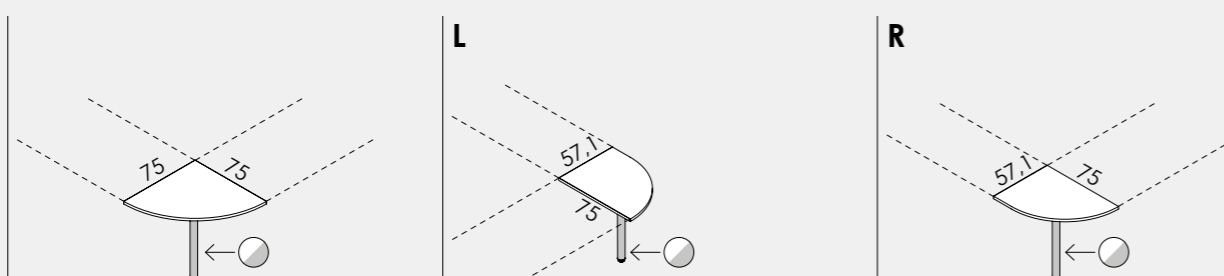

Code	PL27.65M	PL27.66T	PL27.67Z
------	----------	----------	----------

- Components in **CARCASE** colors
- Components in **GROUP 2** colors
- Components in **Types and colors FRONT**
- Aluminium colour components
- Element complete with lock.
- BN7A AR3T
- BI7A AL1A
- BI7A
- Shaped components available with contrasting edging.
- Products made with CLASS 1 flame retardant components.

	<b>SPICCHIO screen holder</b> W 54.5 - Dpt 54.5 - Ht 18 Cor rerchil illit	<b>Pull-out keyboard shelf (for underneath top)</b> W 59 - Dpt 29.5 - Ht 6	<b>ABS cable hole</b> Ø 8	<b>Metal cable hole</b> Ø 8	<b>Electrified cable gland with wireless charging</b> Ø 8 Black colour 1 Schuko 2P 16A 1 USB-A - 2,4 max 1 RJ45 Qi wireless charging standard
Code	P38.27U	P37.46U	P37.79Y	PK72.89R	P38.00X

	<b>Hanging PC holder</b> W 28.7 - Dpt 36 - Ht 56.3	<b>Adjustable hanging PC holder</b> W 16÷22 - Dpt 26.5 - Ht 58 With under top mount.	<b>PC holder with castor wheels with brake</b> W 15 - Dpt 50 - Ht 39	<b>Vertical flex-ducting</b> W 10.8 - Ht 67.5 - Dpt 3.5	<b>Metal tubular Ø 6 support</b> W 12.6 - Dpt 12.6 - Ht 72.5
Code	P38.99L	PL31.38S	P04.74E	P00.64N	P02.61C

	<b>Drawer units on wheels with brake</b> W 45 - Dpt 45.8 - Ht 58.5 3 drawers Ht 16	<b>Adjustable hanging PC holder</b> W 16÷22 - Dpt 26.5 - Ht 58 With under top mount.	<b>PC holder with castor wheels with brake</b> W 15 - Dpt 50 - Ht 39	<b>Vertical flex-ducting</b> W 10.8 - Ht 67.5 - Dpt 3.5	<b>Metal tubular Ø 6 support</b> W 12.6 - Dpt 12.6 - Ht 72.5
Code	PK47.03V	PK47.04B	Code	P02.62H	P02.63P
ONE	matte				
	glossy				
CLUB					

	<b>Pen holder for drawer</b> W 35.5 - Dpt 20 - Ht 2.5	<b>Castor wheels with brake</b> Pack of 4 Ht 8	<b>Pen holder for drawer</b> W 36.2 - Dpt 17.5 - Ht 1.5	
Code	P39.99P	P07.00N	Code	P02.64U

<b>Office chairs</b> Black frames and wheels.	<b>Chair</b> Without armrests.	<b>Chair</b> With armrests.	<b>Armchair</b> With wheels and swivel With pneumatic suspension, without armrests. Ht back Min 90 Max 103.	<b>Armchair</b> With wheels and swivel With pneumatic suspension and armrests. Ht back Min 90 Max 103.
<b>BERLIN fabric</b> 	 Ht 80 Dpt 60 W 53 Ht seat 46	 Ht 80 Dpt 60 W 63 Ht seat 46	 Ht adjust. Dpt 65 W 64 Ht seat 44÷57	 Ht adjust. Dpt 65 W 64 Ht seat 44÷57
Code	P65.11D	P65.10Y	P65.09T	P65.08N

**OPTIONAL:** p. 409

- A - Extra colors for Drawer units
- B - Drawers and big drawers with soft-close

**CLUB**  
drawers and big drawers  
CHARM with soft-close "Quadro" type slides as standard (without surcharges)

**UP & UP bookshelves**

UP & UP bookshelf - Technical information	714
UP & UP bookshelf - Hanging and shelf	715
UP & UP bookshelf - Examples of compositions	716

# UP & UP bookshelf - Technical information

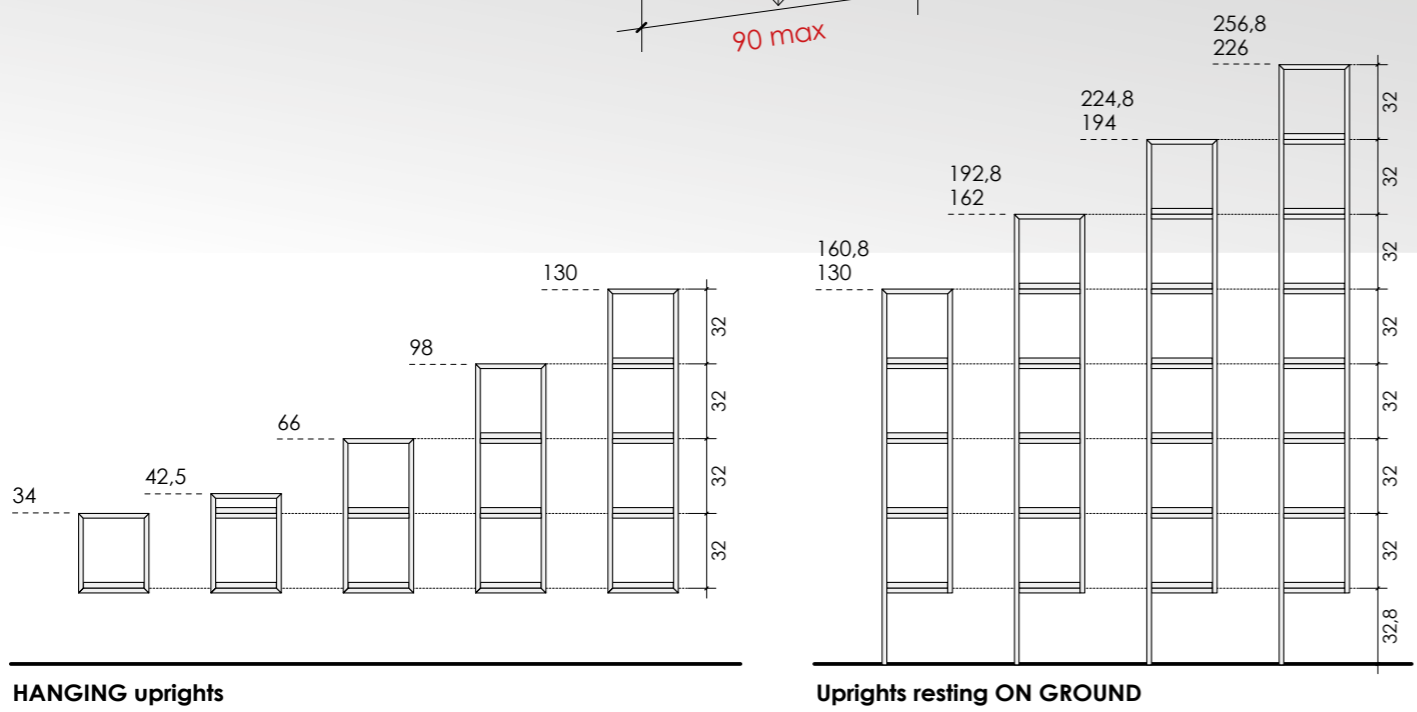
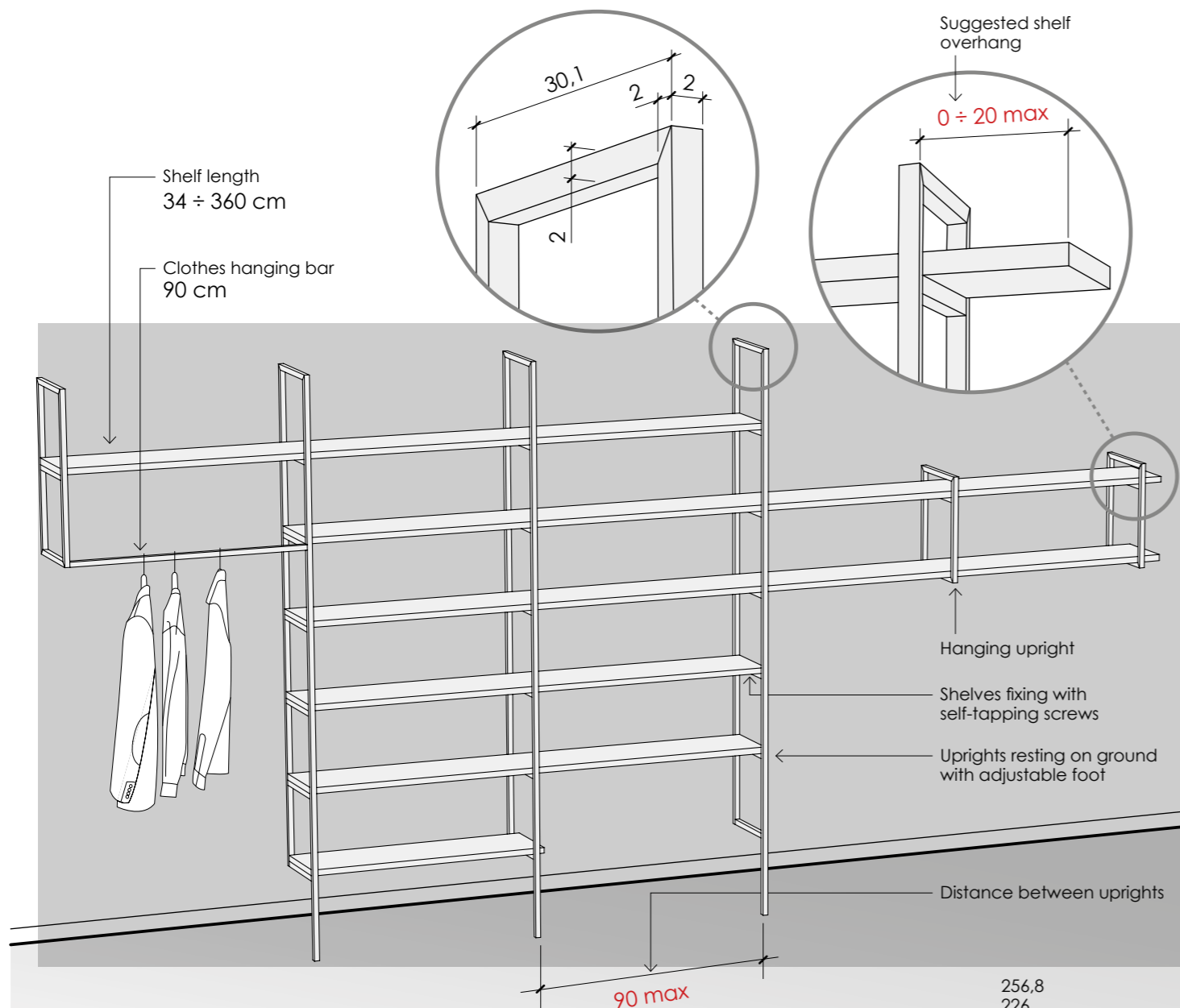

Components in GROUP 2 colors  
 DS9L GZ8T

# UP & UP bookshelf - Hanging and shelf

We recommend using our graphic software. It is necessary to plot and/or send a drawing of the whole composition.

## Metal hanging Dpt 30,1 W 2

All the types of uprights can be used in sequence; in the quantity required and depending on personal taste. **The maximum recommended distance between one upright and another (to prevent the shelves from flexing) is 90 cm (92 cm between the central hole), see diagram shown here.** The uprights are fitted with self-threaded screws to fasten the shelves, but not with plugs for fastening to the wall. The choice of type of wall plugs to use should be made by the assembler based on the characteristics of the walls.

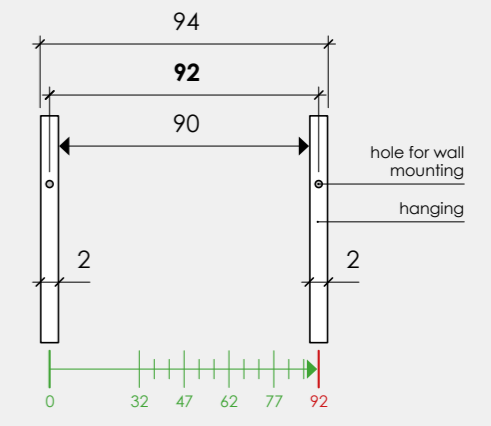

### UPRIGHTS

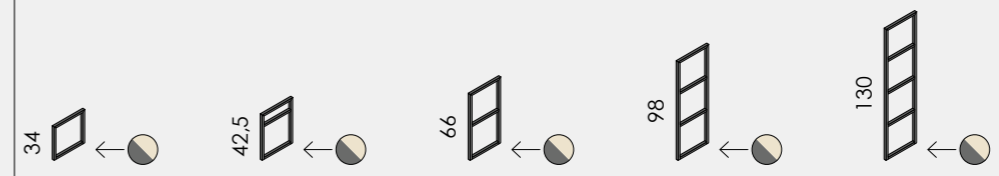

Code	PL66.51P	PL66.52V	PL66.53B	PL66.54H	PL66.55Q
------	----------	----------	----------	----------	----------

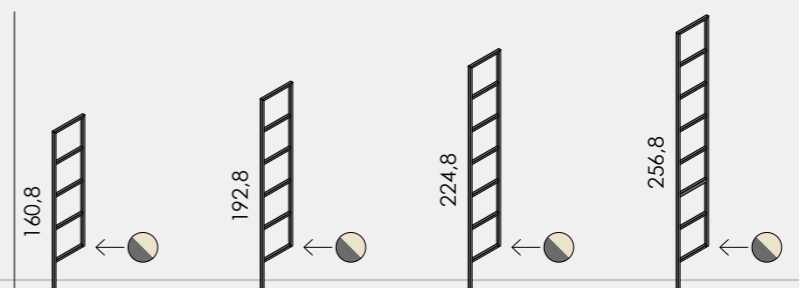

Code	PL66.56W	PL66.57C	PL66.58K	PL66.59R
------	----------	----------	----------	----------

## Custom-made shelves

Dpt 26  
Th 2,5

The made-to-measure shelf allows you to obtain the best aesthetic solutions for your requirements and personal taste. **The length of the shelf must be calculated by adding 2 cm for every upright on which the shelf rests to the distance between the uprights (X); it is also possible to have an overhang of 20 cm per side.** The shelf can end with a different overhang on the left and right side.

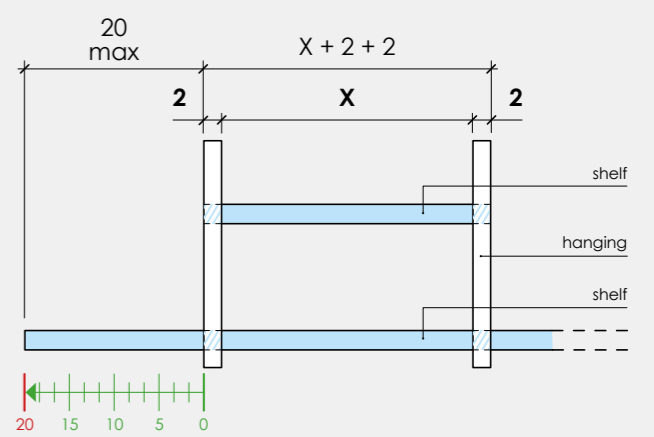

Max 360 Min 34

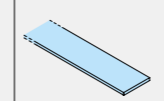

Code	PL66.60N
------	----------

**Maximum load for UP & UP hanging bookshelf: 3 kg every 10 linear cm of the shelf.**  
 N.B. for loads evenly distributed.

For example a library suspended as a drawing will have a maximum capacity of **112.8 Kg.**

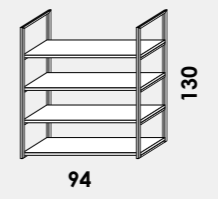

# UP & UP bookshelf - Examples of compositions

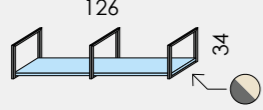
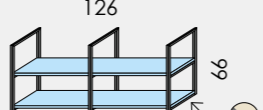
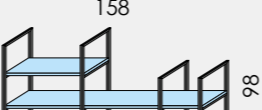
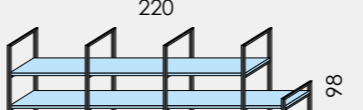
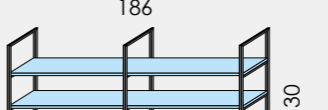
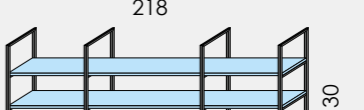
	<p><b>Uprights:</b> Ht 34 (3)</p> <p><b>Shelves:</b> W 126 (1)</p> 	<p><b>Uprights:</b> Ht 66 (3)</p> <p><b>Shelves:</b> W 126 (2)</p> 	<p><b>Uprights:</b> Ht 66 (2) Ht 98 (2)</p> <p><b>Shelves:</b> W 34 (1) W 64 (2) W 158 (1)</p> 	<p><b>Uprights:</b> Ht 42,5 (1) Ht 98 (4)</p> <p><b>Shelves:</b> W 34 (1) W 126 (1) W 188 (1) W 220 (1)</p> 	<p><b>Uprights:</b> Ht 130 (3)</p> <p><b>Shelves:</b> W 186 (4)</p> 	<p><b>Uprights:</b> Ht 66 (2) Ht 130 (2)</p> <p><b>Shelves:</b> W 64 (2) W 218 (2)</p> 
<b>Code</b>	<b>PL66.61U</b>	<b>PL66.62A</b>	<b>PL66.63G</b>	<b>PL66.70T</b>	<b>PL66.71Z</b>	<b>PL66.72F</b>

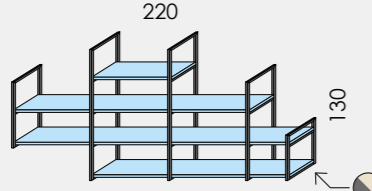
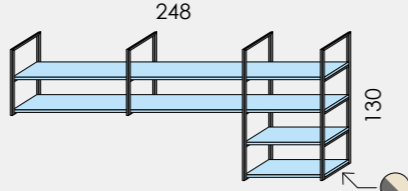
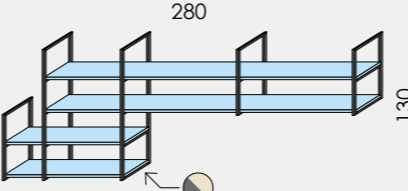
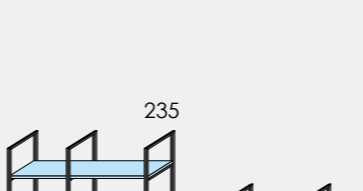
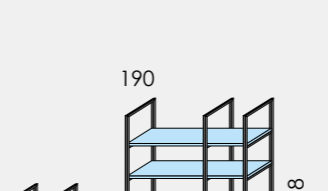
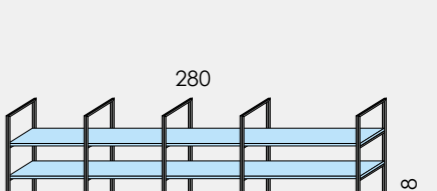
	<p><b>Uprights:</b> Ht 42,5 (1) Ht 66 (1) Ht 98 (1) Ht 130 (2)</p> <p><b>Shelves:</b> W 64 (1) W 158 (1) W 188 (1) W 220 (1)</p> 	<p><b>Uprights:</b> Ht 66 (2) Ht 130 (2)</p> <p><b>Shelves:</b> W 64 (2) W 248 (2)</p> 	<p><b>Uprights:</b> Ht 66 (3) Ht 130 (2)</p> <p><b>Shelves:</b> W 96 (2) W 248 (2)</p> 	<p><b>Uprights:</b> Ht 42,5 (2) Ht 160,8 (3)</p> <p><b>Shelves:</b> W 111 (2) W 235 (2)</p> 	<p><b>Uprights:</b> Ht 42,5 (2) Ht 192,8 (3)</p> <p><b>Shelves:</b> W 34 (1) W 96 (4) W 190 (1)</p> 	<p><b>Uprights:</b> Ht 192,8 (5)</p> <p><b>Shelves:</b> W 280 (5)</p> 
<b>Code</b>	<b>PL66.64P</b>	<b>PL66.65V</b>	<b>PL66.66B</b>	<b>PL66.73N</b>	<b>PL66.74U</b>	<b>PL66.75A</b>

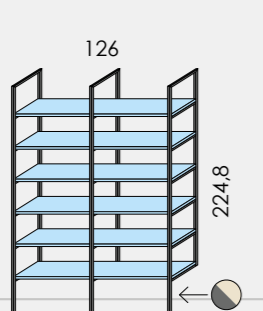
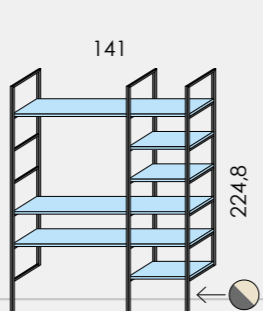
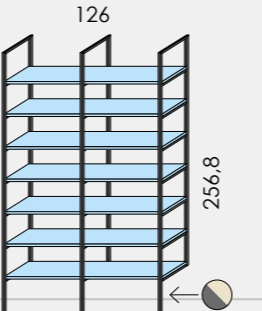
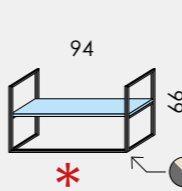
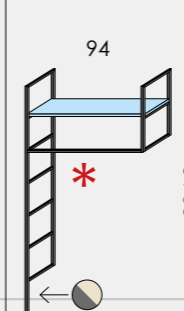
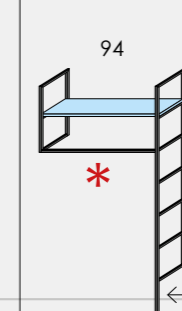
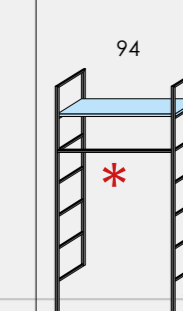
	<p><b>Uprights:</b> Ht 224,8 (3)</p> <p><b>Shelves:</b> W 126 (6)</p> 	<p><b>Uprights:</b> Ht 224,8 (3)</p> <p><b>Shelves:</b> W 49 (3) W 141 (3)</p> 	<p><b>Uprights:</b> Ht 256,8 (3)</p> <p><b>Shelves:</b> W 126 (7)</p> 	<p><b>Compositions with clothes hanging bar W 90</b></p>			
	<p><b>Uprights:</b> Ht 66 (2)</p> <p><b>Shelves:</b> W 94 (1)</p> 	<p><b>Uprights:</b> Ht 224,8 (1) Ht 66 (1)</p> <p><b>Shelves:</b> W 94 (1)</p> 	<p><b>Uprights:</b> Ht 66 (1) Ht 224,8 (1)</p> <p><b>Shelves:</b> W 94 (1)</p> 	<p><b>Uprights:</b> Ht 224,8 (2)</p> <p><b>Shelves:</b> W 94 (1)</p> 			
<b>Code</b>	<b>PL66.67H</b>	<b>PL66.68Q</b>	<b>PL66.69W</b>	<b>PK66.76G</b>	<b>PK66.77P</b>	<b>PK66.78V</b>	<b>PK66.79B</b>

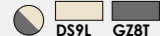
Components in **GROUP 2** colors  
 DS9L GZ8T

\* Maximum load for coat hanger:  
 15 kg. N.B. for loads evenly distributed.



GROUP 1 colors	Rovere Dorian <b>RD5T</b>	Rovere white <b>RW3Q</b>	Noce naturale <b>NN7H</b>	Eucalipto <b>CL1X</b>	Domy <b>DM7P</b>	Bianco UV <b>BU3Q</b>
	Ciliegio bianco <b>CB6K</b>	Malta <b>ML7H</b>	Feltro <b>FL8X</b>	Cemento Masdar <b>CM3Q</b>	Blu indaco <b>BI4B</b>	
	Noce <b>NC4B</b>	Desert <b>DS9L</b>	Canapa <b>CN1X</b>	Moka <b>MK6B</b>	Cipria <b>CP4J</b>	
	Bianco opaco <b>BI7A</b>	Grigio Dorian <b>GL4R</b>	Basalto <b>BS5T</b>	Grigio titanio <b>GZ8T</b>	Rosa bubble <b>RB7Y</b>	
	Agave <b>GV7A</b>	Verde Alpi <b>VA5T</b>	Cadaques <b>CQ3Q</b>	Giallo zafferano <b>GZ8A</b>		
	Blu opale <b>BO7H</b>			Corallo <b>CR5T</b>		

Types and colors FRONT	ONE	matte	Rovere white <b>RW3Q</b>	Rovere Dorian <b>RD5T</b>	Ciliegio bianco <b>CB6K</b>	Noce naturale <b>NN7H</b>	Noce <b>NC4B</b>	Eucalipto <b>CL1X</b>	Malta <b>ML7H</b>	
			Feltro <b>FL8X</b>	Cemento Masdar <b>CM3Q</b>	Bianco opaco <b>BI7A</b>	Desert <b>DS9L</b>	Canapa <b>CN1X</b>	Moka <b>MK6B</b>	Grigio Dorian <b>GL4R</b>	
			Basalto <b>BS5T</b>	Grigio titanio <b>GZ8T</b>	Domy <b>DM7P</b>	Agave <b>GV7A</b>	Verde Alpi <b>VA5T</b>	Cadaques <b>CQ3Q</b>	Blu indaco <b>BI4B</b>	
			Blu opale <b>BO7H</b>	Cipria <b>CP4J</b>	Rosa bubble <b>RB7Y</b>	Giallo zafferano <b>GZ8A</b>	Corallo <b>CR5T</b>			
									Bianco UV <b>BU3Q</b>	
	CLUB	Specify the color of the CLUB handle	Rovere white <b>RW3Q</b>	Rovere Dorian <b>RD5T</b>	Ciliegio bianco <b>CB6K</b>	Noce naturale <b>NN7H</b>	Noce <b>NC4B</b>	Eucalipto <b>CL1X</b>	Malta <b>ML7H</b>	
Feltro <b>FL8X</b>			Cemento Masdar <b>CM3Q</b>	Bianco opaco <b>BI7A</b>	Desert <b>DS9L</b>	Canapa <b>CN1X</b>	Moka <b>MK6B</b>	Grigio Dorian <b>GL4R</b>		
Basalto <b>BS5T</b>			Grigio titanio <b>GZ8T</b>	Domy <b>DM7P</b>	Agave <b>GV7A</b>	Verde Alpi <b>VA5T</b>	Cadaques <b>CQ3Q</b>	Blu indaco <b>BI4B</b>		
Blu opale <b>BO7H</b>			Cipria <b>CP4J</b>	Rosa bubble <b>RB7Y</b>	Giallo zafferano <b>GZ8A</b>	Corallo <b>CR5T</b>				
			Bianco opaco <b>BI7A</b>	Desert <b>DS9L</b>	Canapa <b>CN1X</b>	Moka <b>MK6B</b>	Grigio Dorian <b>GL4R</b>	Basalto <b>BS5T</b>	Grigio titanio <b>GZ8T</b>	
			Domy <b>DM7P</b>	Agave <b>GV7A</b>	Verde Alpi <b>VA5T</b>	Cadaques <b>CQ3Q</b>	Blu indaco <b>BI4B</b>	Blu opale <b>BO7H</b>	Cipria <b>CP4J</b>	
			Rosa bubble <b>RB7Y</b>	Giallo zafferano <b>GZ8A</b>	Corallo <b>CR5T</b>					
	WINDOW	Specify the color of the aluminum frame	Trasparente <b>TR9M</b>	Trasparente fumé <b>FT8P</b>	Stop-sol <b>ST6P</b>	Specchio <b>SP7L</b>				
			Alluminio <b>AL1A</b>	Titan grey <b>TG7H</b>						

**INFINITY bookcases**

INFINITY bookcases - Introduction	720
INFINITY bookcases - The structure	722
INFINITY bookcases - Technical information	724
INFINITY bookcases - TV compartments	726
INFINITY bookcases - Rotating 180° TV compartment	728
INFINITY bookcases - Minimum distances for assembling	729
INFINITY bookcases - Lighting	730
INFINITY bookcases - Customized cuts	731
INFINITY doors	732
INFINITY doors for full corner	734
INFINITY doors vasistas and folding Ht 32	734
Drawers INFINITY	735
Inside drawers INFINITY	735
Sliding doors INFINITY	736



# INFINITY bookcases - Introduction

- 1 Suspended bookcase
- 2 Suspended corner bookcase
- 3 Floor standing bookcase
- 4 Floor standing bookcase for ceiling fixing
- 5 Floor standing bookcase for ceiling fixing - For passage
- 6 Corner bookcase for ceiling fixing
- 7 Floor standing maxi bookcase
- 8 Dividing panels
- 9 End unit
- 10 Floor standing modular units/PODIO bench
- 11 Floor standing semi-suspended bookcase
- 12 WINDOW doors
- 13 Folding door
- 14 System save space CLICK (example: double bed and shelf)
- 15 Floor standing boiserie
- 16 Floor standing bookcase with desk
- 17 Standard door
- 18 Sliding doors
- 19 Inside drawers
- 20 Bookcase with TV compartment
- 21 Vasistas door
- 22 Drawers

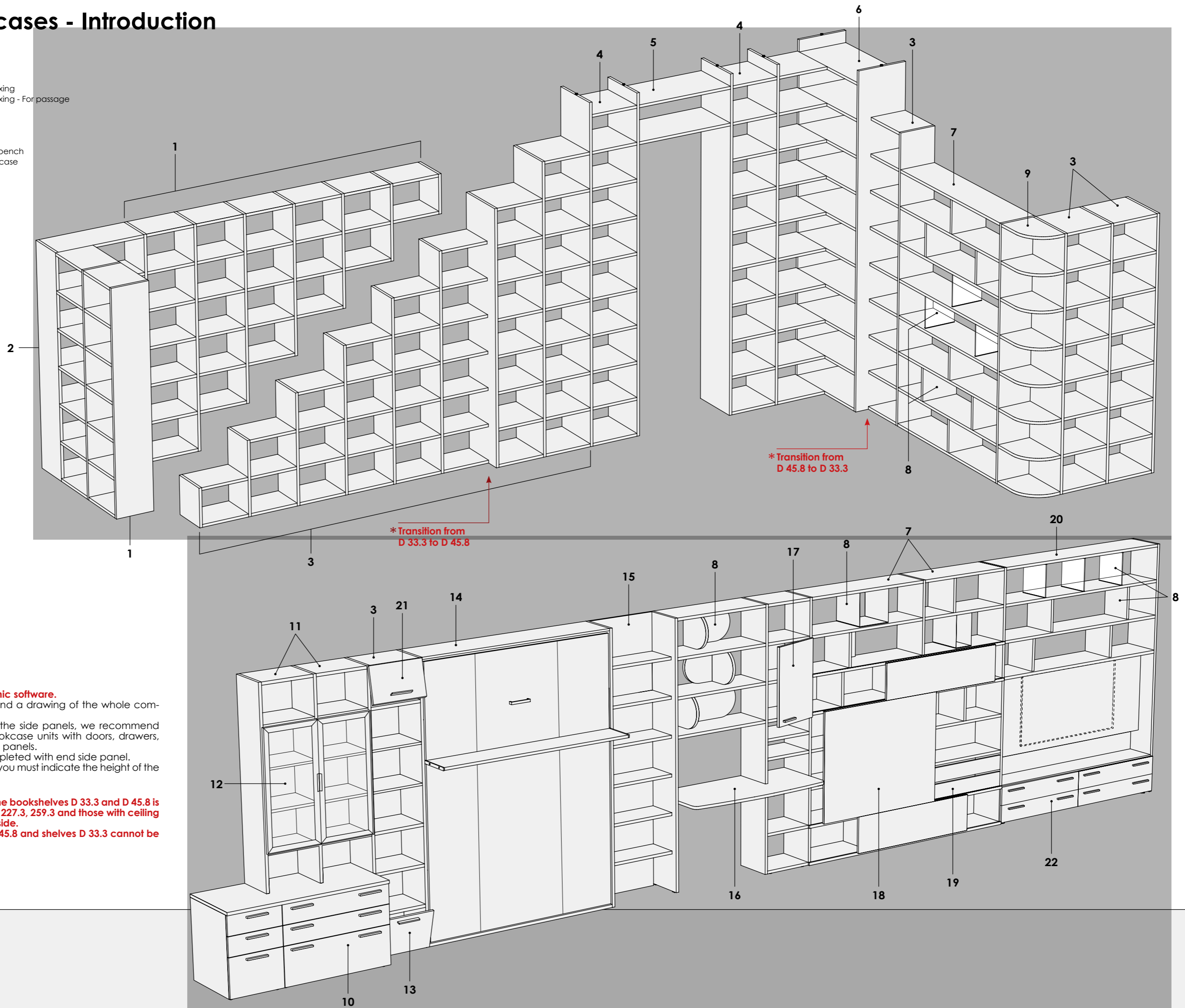

## When ordering:

- We recommend using our graphic software.
- It is necessary to plot and/or send a drawing of the whole composition.
- For a correct customization of the side panels, we recommend you to integrate the modular bookcase units with doors, drawers, shelves, back panels and dividing panels.
- Each composition must be completed with end side panel.
- For side panels with ceiling fixing you must indicate the height of the room (floor-ceiling).

\* The change in depth between the bookshelves D 33.3 and D 45.8 is possible with bookshelves H 195.3, 227.3, 259.3 and those with ceiling block, always aligned with a wall side. Housing spaces with side panel D 45.8 and shelves D 33.3 cannot be equipped with doors or drawers.

# INFINITY bookcases - The structure

## Components

The back of each component is properly finished.  
 Side panels have customized holes for shelves every 32 cm; upon request holes can be done every 16 cm.  
 The hardware is placed in a personalized fashion according to the position of the components.  
 The back panel, in between the side panels, can be assembled frontally (if it's for wall bookcase) or from the back (if it's for a centrally-positioned bookcase).  
 The doors are equipped with hinges decelerate (no on the doors for the Full corner).  
 The vasistas/folding doors are provided with concealed hinges.  
 The doors, with the exception of those CLUB and WINDOW (vasistas and folding doors included) are also available with push pull.  
 Drawers are provided with slowed down "QUADRO" metal runners which have adjustable height with interior CHARM finish.  
 An illumination system can be assembled on shelves of bookcases with back panel.  
 The transparent tempered glass shelves comply with the UNI EN 12150-1 standard.

## Safety notes

Each bookcase is provided with a metal plate for wall fixing, but not with the hardware for the wall positioning of the plate. The choice of hardware depends on the wall conditions and should be made by the assembler.  
 Fixing to wall or to ceiling is required to guarantee stability. Side panels with ceiling fixing do not require wall fixing because the mounting between floor and ceiling is performed with adjustable feet (top and bottom) which allow an adjustment of max 10 mm for each side (20 total). We recommend that you check the room height in more than one point in order to find any excessive differences. With false ceilings you should check that in the event of inflection, the height difference does not exceed the 2 cm maximum adjustable range of the feet.

## Recess for skirting board

A recess to allow for the skirting board can be requested (for a surcharge) on the floor-standing bookshelves Dpt 33.3 and 45.8 with and without back panel, in widths 30 - 45 - 60 - 90. This processing is possible on open bookshelves equipped with swing doors, pull-down doors, drawers (not internal), glass inner shelves without lighting and panel inner shelves, the latter only for bookshelves without a back panel. The skirting board recess in the side panel is without edging.

**When placing the order:** for the relative bookshelves, indicate YES for skirting board processing in the SKIRTING BOARD PROCESSING variant in Metron 4: all elements of the bookshelf affected by said processing (side, bottom, and back panel if present) will be adapted.

**N.B.** as a result of these changes, the price of the bookcase could be different from the standard one.

Example of skirting board recess in bookshelf with back panel:

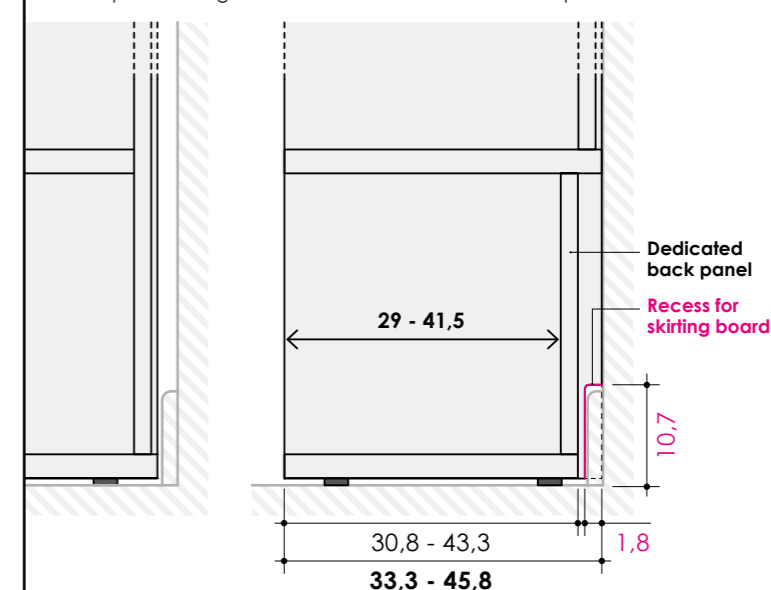

Self standing bookcase	W 30	W 45	W 60	W 90
Surcharge for single side panel				
Dpt 32,5				
Dpt 45				

Self standing bookcase (Dpt 33.3/Dpt 45.8)

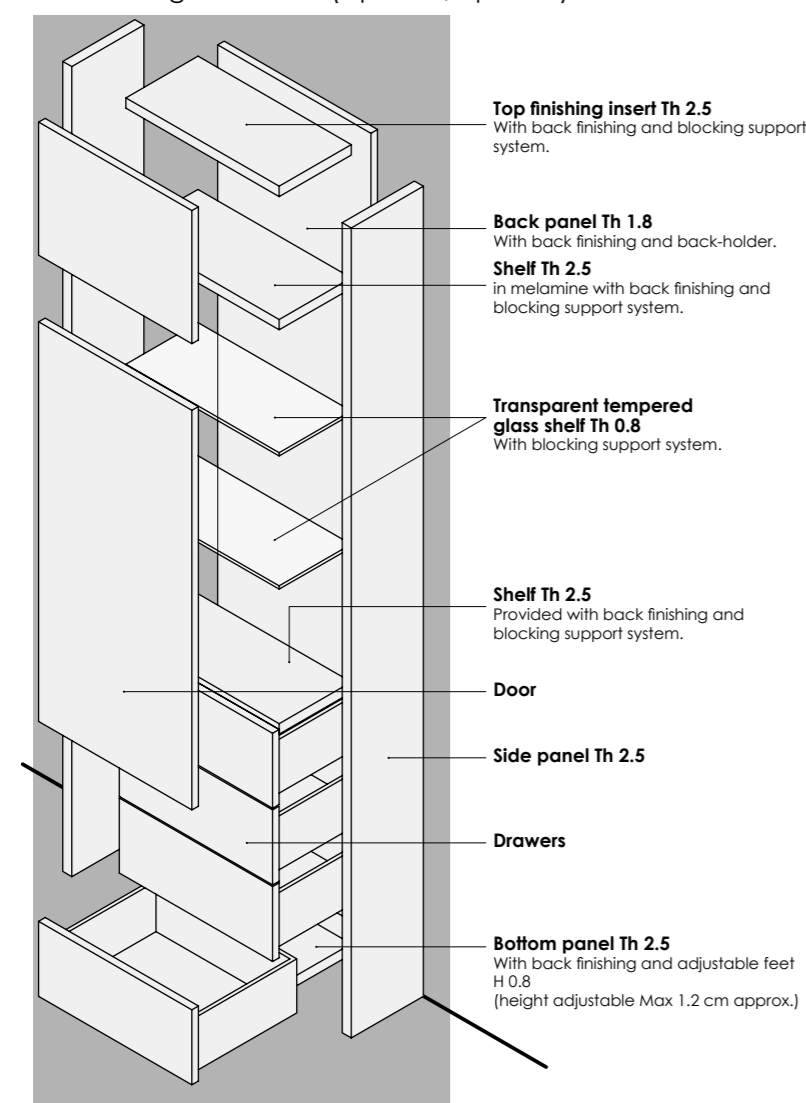

Full corner (Dpt 33.3/Dpt 45.8)

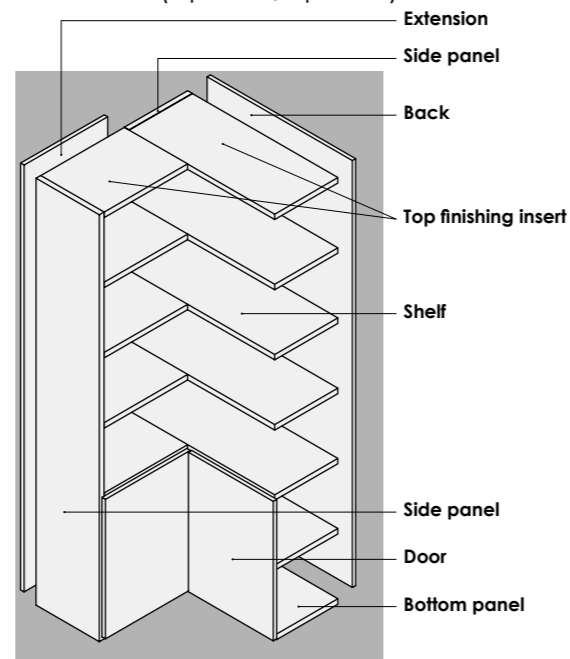

Curved bookcase end unit (Dpt 33.3/Dpt 45.8)

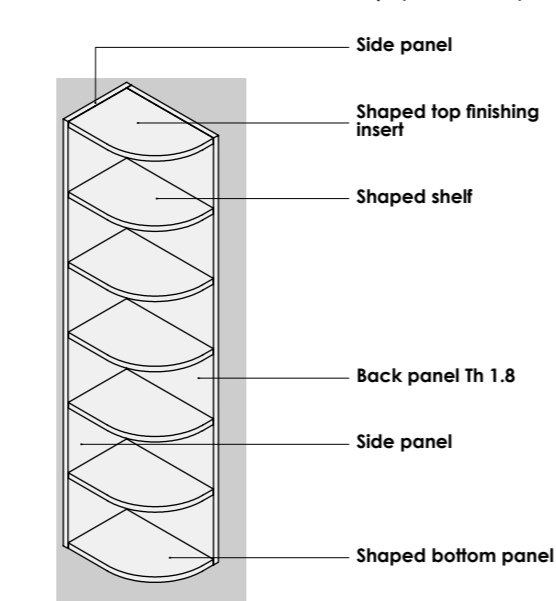

Semi-suspended bookcase (Dpt 33.3)

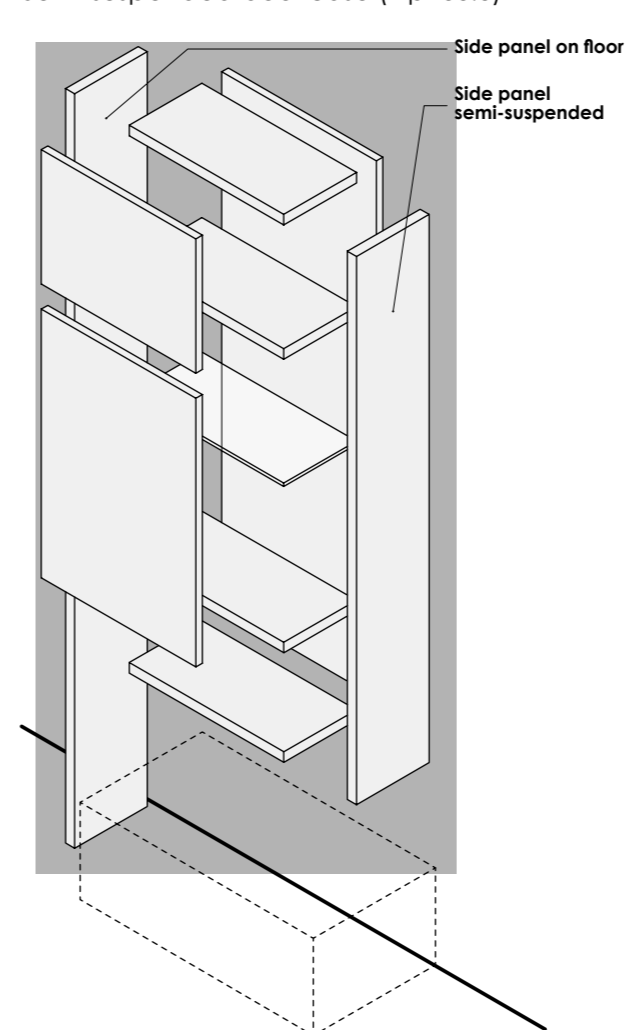

Suspended bookcase (Dpt 33.3)

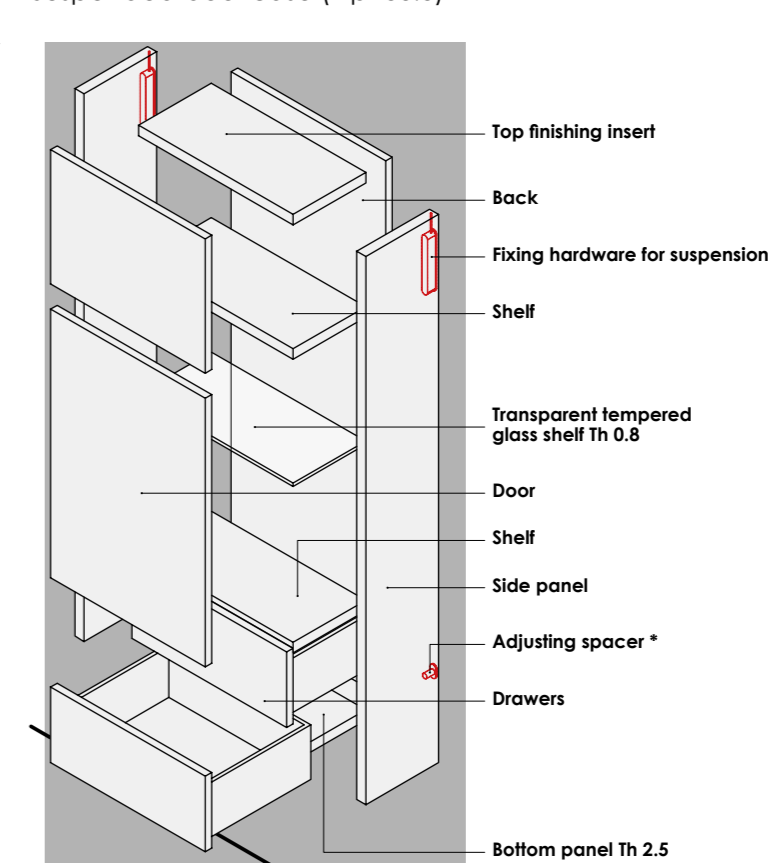

\* The adjusting element allows any wall imperfections to be cleared.

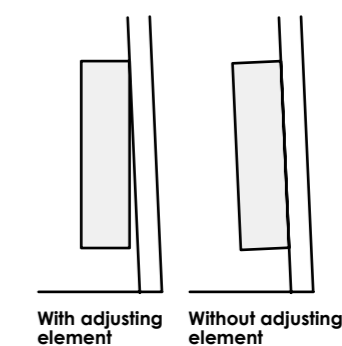

# INFINITY bookcases - Technical information

## Bookcase with back panel

Fixing to wall or to ceiling is required to guarantee stability.  
 The bookcases with back panel proposed in the price list have a full-height back panel, except for the bookcases with side to be secured to the ceiling, whereby the last counter-opposing housing space is without a back panel.  
 The back panel for W 30, 45, 60, 90 modular units is supplied all in one.  
 The back panel for W 120, 150, 180 modular units is not supplied all in one (in 3 pieces).  
 The back panel for W 210, 240, 270 modular units, has a supporting function and it is provided in pieces; one for each unit in height. In this case the positioning of the shelves is fixed every 32 cm.  
 Every back panel has finishings.  
 They can be equipped with hinged doors, drawers, bottom-hinged doors, top-hinged doors and sliding doors up to maximum height of 259.3 cm. In bookshelves with side panel for securing to the ceiling, the last counter-opposing housing space cannot be equipped.  
 Two-sided open compartments.

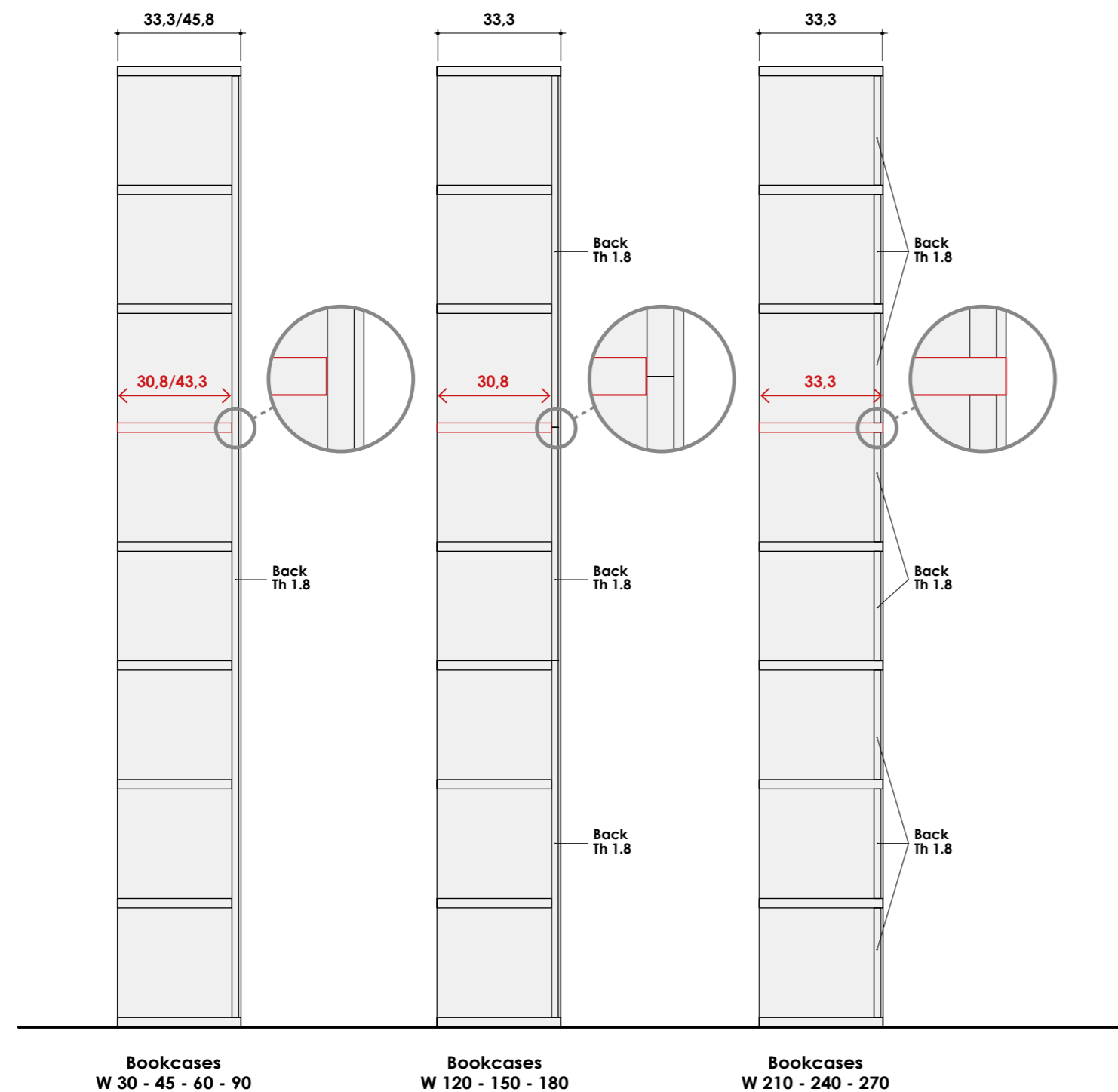

## Pass-through bookcase

Fixing to wall or to ceiling is required to guarantee stability.  
 They can be equipped with hinged doors, drawers, bottom-hinged doors, top-hinged doors and sliding doors up to maximum height of 259.3 cm. In bookshelves with side panel for securing to the ceiling, the last counter-opposing housing space cannot be equipped.  
 Two-sided open compartments.  
 Compartments with only one accessible side.  
 Back panels have finishings.  
 They are composed of Dpt 33.3/45.8 shelves; where the compartment is closed with back panel, the shelves assembled are Dpt 30.8/43.3.

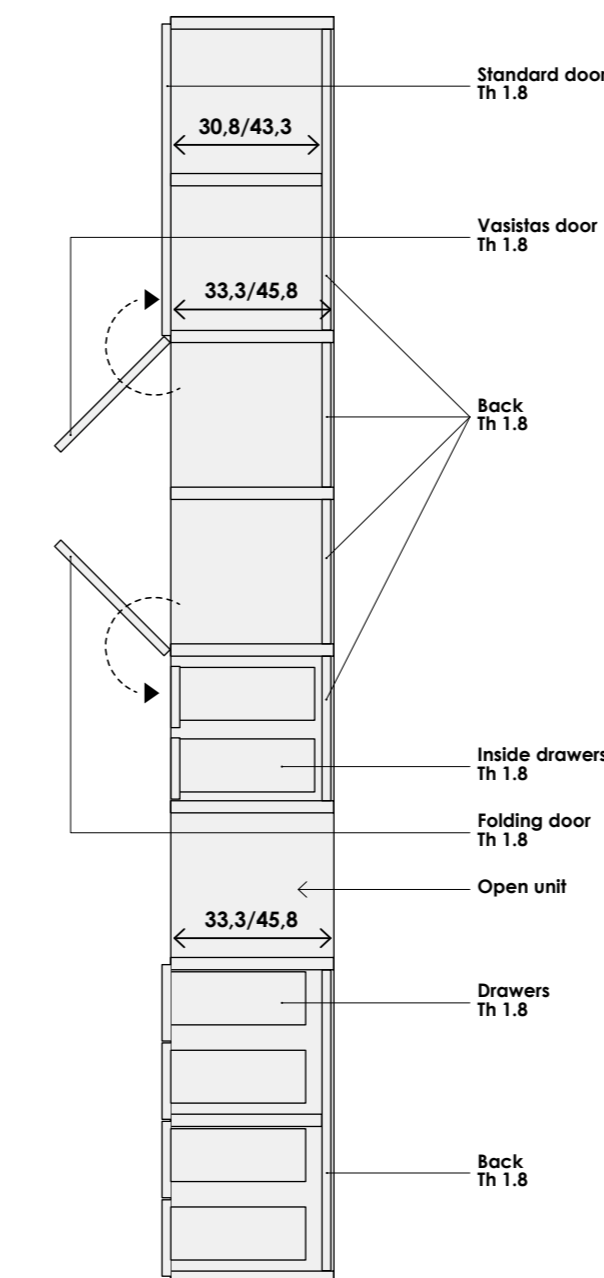

## Two-sided bookcase

Fixing to wall or to ceiling is required to guarantee stability.  
 They are entirely composed of Dpt 33.3/45.8 shelves.  
 They can be equipped with hinged doors, drawers, bottom-hinged doors, top-hinged doors and sliding doors up to maximum height of 259.3 cm. In bookshelves with side panel for securing to the ceiling, the last counter-opposing housing space cannot be equipped.  
 Two-sided open compartments.  
 Both side accessible compartments, except for those which have drawers which are accessible only from one side and have always finished back panel.  
 Not available on Corner units and End units.

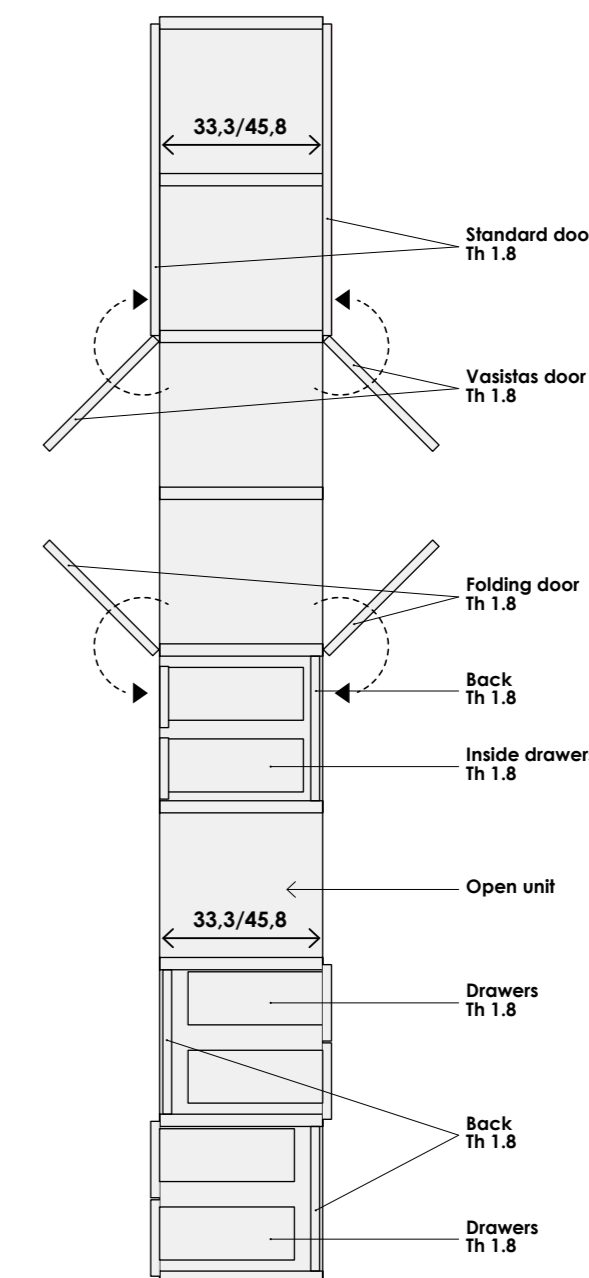

# INFINITY bookcases - TV compartments

## Model 1

The back panel of the TV compartment model 1 is always provided with ABS cable hole Ø 8, positioned during assembly by the assembler, which allows cables of different electronic devices to be hidden.

The large space between the back panel and the front part of the TV compartment (26 cm) allows the positioning of the TV with foot stand together with other devices such as DVD players, decoders, game consoles, etc. on the side or in the niche underneath.

The bottom panel of the TV compartment is always provided with a hole in the middle usable for various cables.

You can choose to position your TV stand away from walls, and to do so you can order separately a covering back panel from the catalogue.

The Model 1 TV compartment is always provided with cable grommet and led lighting which is positioned in the top part of the compartment and is also completed with a touch switch.

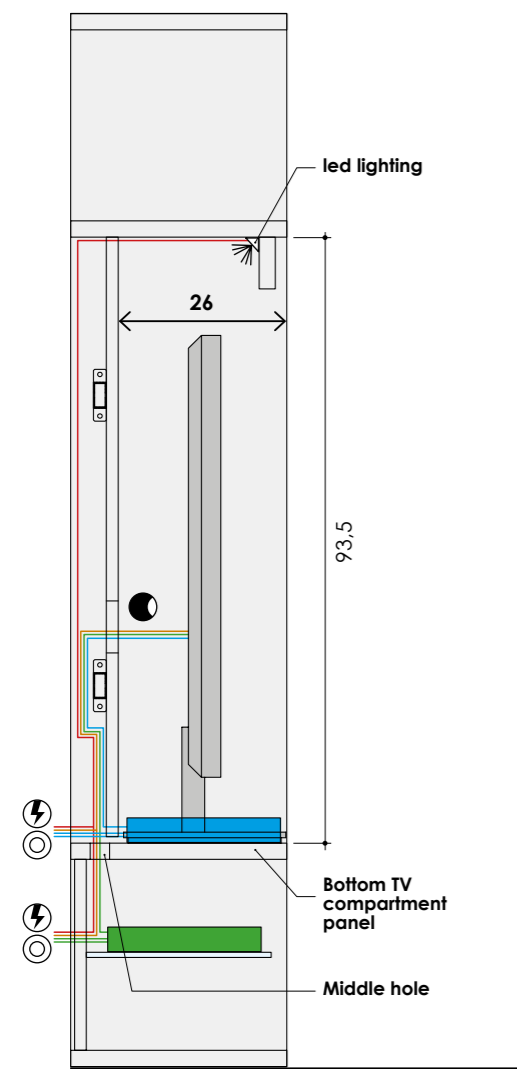
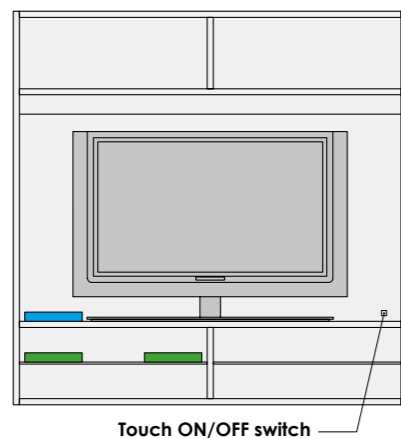

## Model 2

The back panel of the TV compartment model 2 is always provided with ABS cable hole Ø 8, positioned during assembly by the assembler, which allows cables of different electronic devices to be hidden.

The space between the back panel and the front part of the TV compartment (16 cm) allows the positioning of suspended TVs.

All other devices such as DVD players, decoders, game consoles, etc. can be placed in the storage compartment underneath the TV.

The bottom panel of the TV compartment is always provided with a hole in the middle usable for various cables.

You can choose to position your TV stand away from walls, and to do so you can order separately a covering back panel from the catalogue.

The Model 2 TV compartment is always provided with cable grommet and led lighting which is positioned in the top part of the compartment, with a touch switch and metal support for TV.

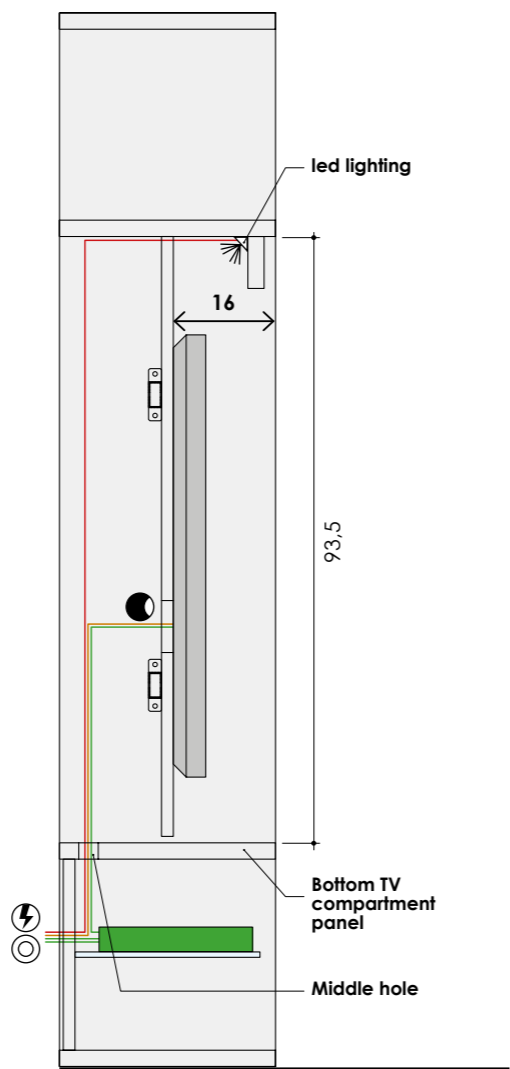
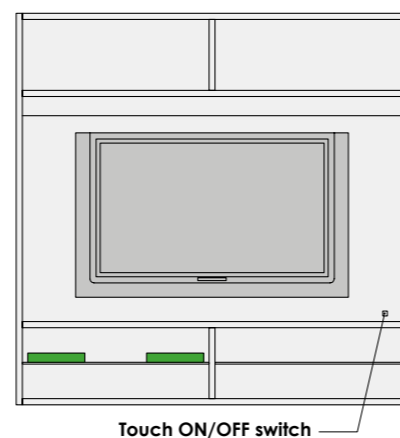

## Model 3

The back panel of the TV compartment model 3 is always provided with ABS cable hole Ø 8, positioned during assembly by the assembler, which allows cables of different electronic devices to be hidden.

This particular type of structure is intended for suspended or self standing TVs and allows you to choose whether to place the electronic devices such as DVD players, decoders, game consoles, etc. on the side of the TV or in the niche underneath.

The thin panel beneath the TV compartment, allows the storage of DVD cases or books and it is easily removable for maintenance.

The bottom panel of the TV compartment is always provided with a hole in the middle usable for various cables.

You can choose to position your TV stand away from walls, and to do so you can order separately a covering back panel from the catalogue.

The Model 3 TV compartment is always provided with cable grommet and led lighting which is positioned in the bottom part of the compartment, with a touch switch and metal support for TV.

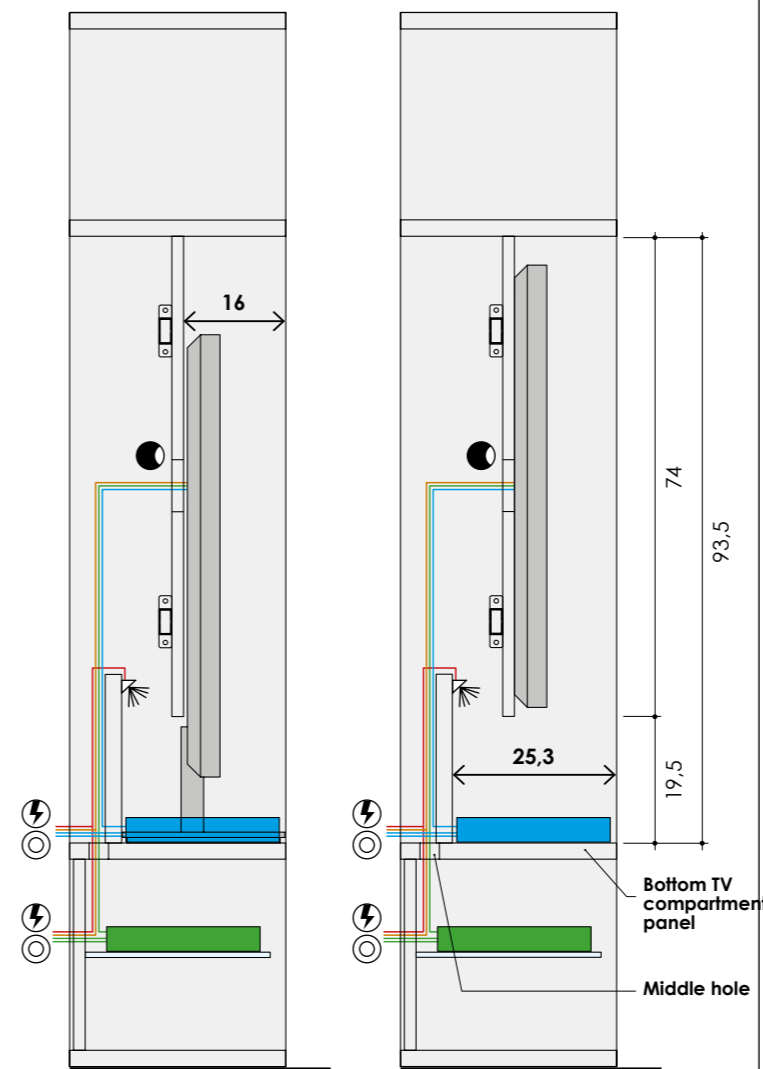
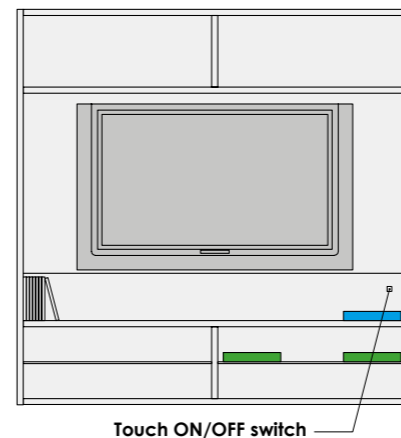

## Model 4

The back panel of the TV compartment model 4 is always provided with ABS cable hole Ø 8, positioned during assembly by the assembler, which allows cables of different electronic devices to be hidden.

This particular type of frame shaped structure is intended for suspended or self standing TVs and allows you to choose whether to place the electronic devices such as DVD players, decoders, game consoles, etc. at the side of the TV or in the niche underneath.

The frame-shaped part is easily removable to allow maintenance.

The bottom panel of the TV compartment is always provided with a hole in the middle usable for various cables.

You can choose to position your TV stand away from walls, and to do so you can order separately a covering back panel from the catalogue.

The model 4 TV compartment is always provided with cable grommet and 2 led spot lights placed in the top part of the compartment, with a touch switch and metal support for TV.

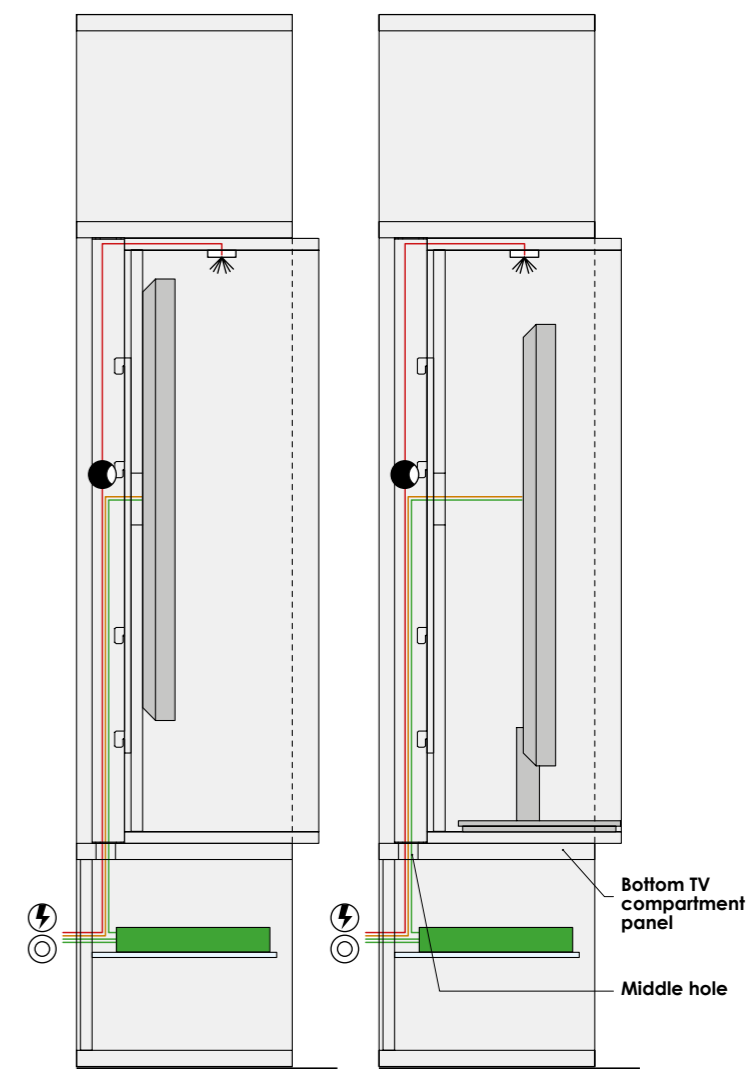
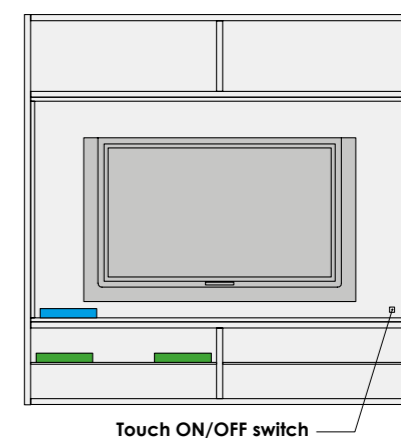

- ⊙ Aerial
- ⚡ Power source
- Cable grommet covering
- ☀ led lighting



# INFINITY bookcases - Rotating 180° TV compartment

Structure consisting of: a front and rear panel, metal mechanism for 180° rotation, and outer frame made with a series of 17.4 cm deep fixed inner shelves present on both sides. It is supplied with a cable grommet to be positioned during installation by the assembler to conceal the various cables.

The swivel mechanism includes an internal cable grommet and cover to be positioned in the space below the TV housing space, and internal adjustment to keep the panel aligned.

Any equipment (such as DVD players, decoders, consoles, etc.) can be placed in the spaces underneath the TV housing space.

Accessible rear part for maintenance.

The bottom panel of the TV housing space has a central hole through which to pass the various cables.

Position in the centre of the room.

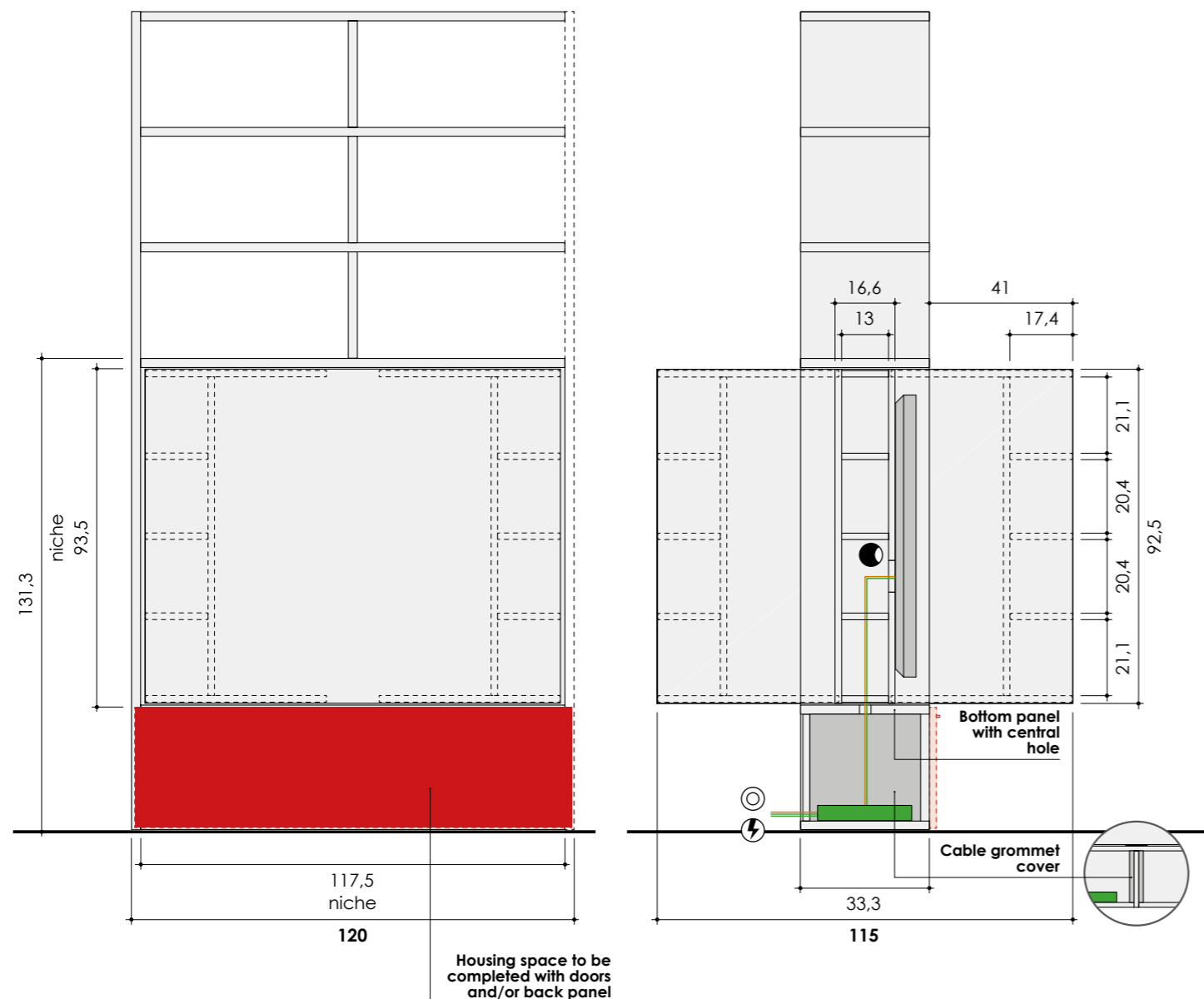
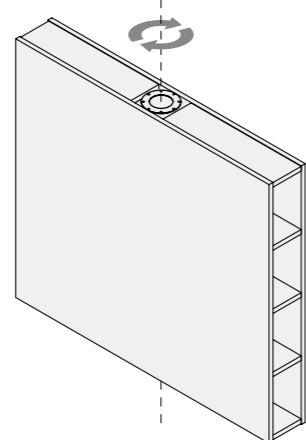

- ⊙ Aerial
- ⚡ Power source
- Cable grommet covering

# INFINITY bookcases - Minimum distances for assembling

## HEIGHT

### SELF STANDING Bookcase

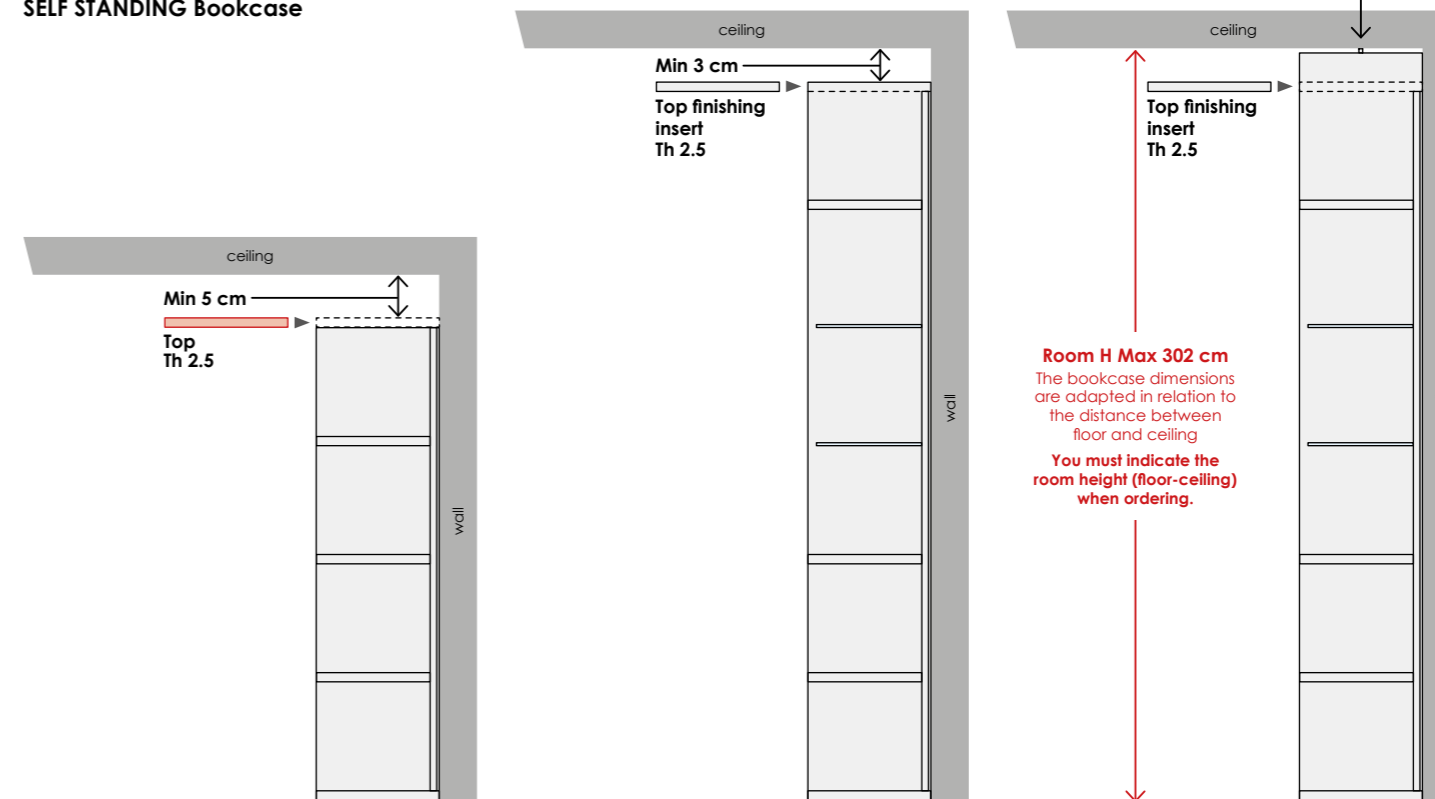

Side view with self standing Bookcase from Ht 35.3 to Ht 163.3 (included) with top finishing insert

Side view with self standing Bookcase from Ht 195.3 to Ht 259.3 (included) with top finishing insert

Side view with Floor standing bookcase customised for ceiling fixing from H 230 to 302 Max.

We recommend that you check the room height in more than one point in order to find any excessive differences. With false ceilings you should check that in the event of inflection, the height difference does not exceed the 2 cm maximum adjustable range of the feet.

### SUSPENDED Bookcase (Dpt 33.3)

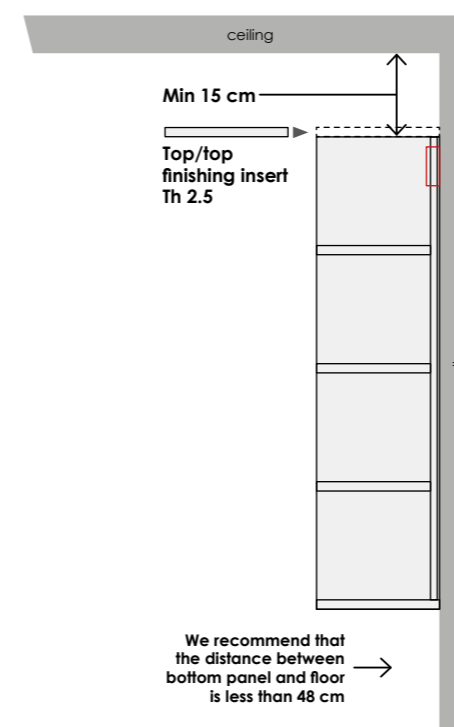

Side view with suspended Bookcase

## WIDTH

### SELF STANDING and SUSPENDED Bookcase (Dpt 33.3)

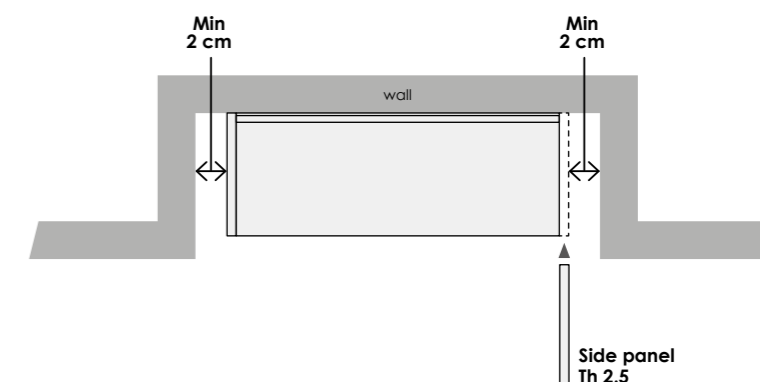

## INFINITY bookcases - Lighting

### Wooden shelf with led light

The wooden shelf light is a led strip (60 led/m) assembled on the back side of the shelf. The strip shares the same length with the shelf and by reflecting the light on the back panel, it enlightens the compartments above and below. The colour tone of the led strip is natural. We recommend using this type of light system when there is a back panel. We provide a power pack (with a surcharge) able to support from 1 to 6 shelves W 45/60 or from 1 to 4 shelves W 90.

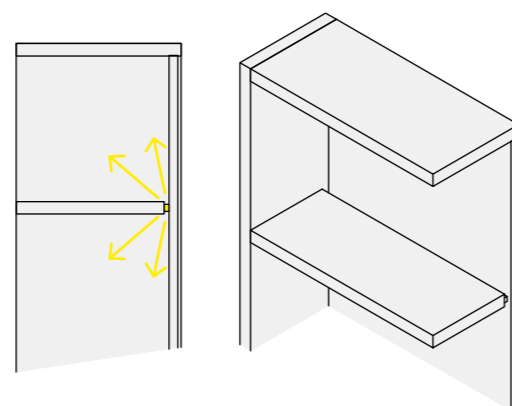

### Transparent tempered glass shelf with led light

The transparent tempered glass shelf light system consists in a PVC profile with led strip (60 led/m) assembled on the back side of the shelf. The strip shares the same length with the shelf, it gives a front lighting and by reflecting the light on the back panel, it enlightens the compartments above and below. The colour tone of the led strip is natural. We recommend using this type of light system when there is a back panel. We provide a power pack (with a surcharge) able to support from 1 to 6 shelves W 45/60 or from 1 to 4 shelves W 90.

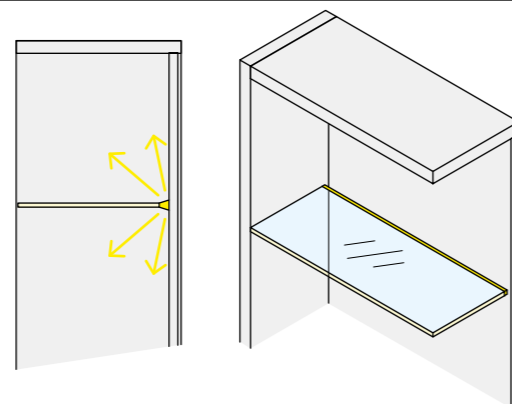

### Led spot light

The colour tone of the led strip is natural. We provide a power pack (with a surcharge) able to support from 1 to 6 spotlights. We recommend using this type of light system only on top finishing insert. Spot lights are assembled as showed below (wiring in sight).

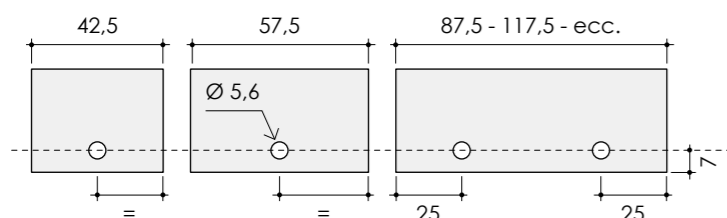
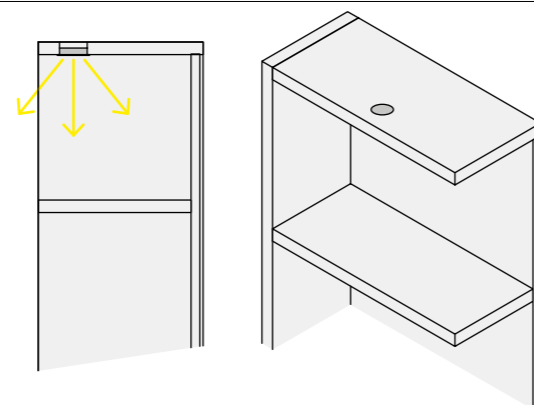

### On/off switch

The on/off switching of the led spot or led strip light can be done in 2 different ways:

1) By connecting the power supply unit to your home electrical system and using your own standard power switch.

2) By ordering our wireless on/off switch from catalogue. This switch allows you to turn on or off all the led lights in the bookcase, up to a maximum of 30 shelves or spot lights.

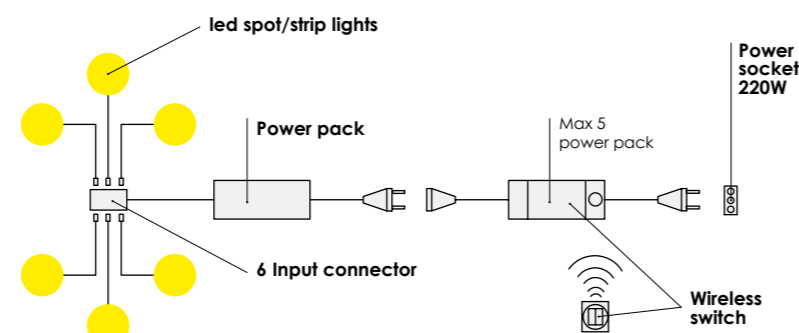
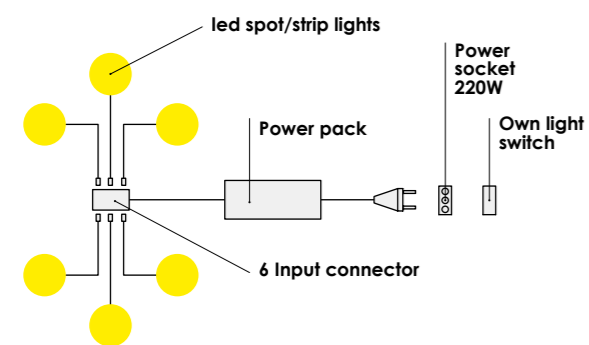

## INFINITY bookcases - Customized cuts

Customized cuts can be made only if you provide an explanatory drawing.

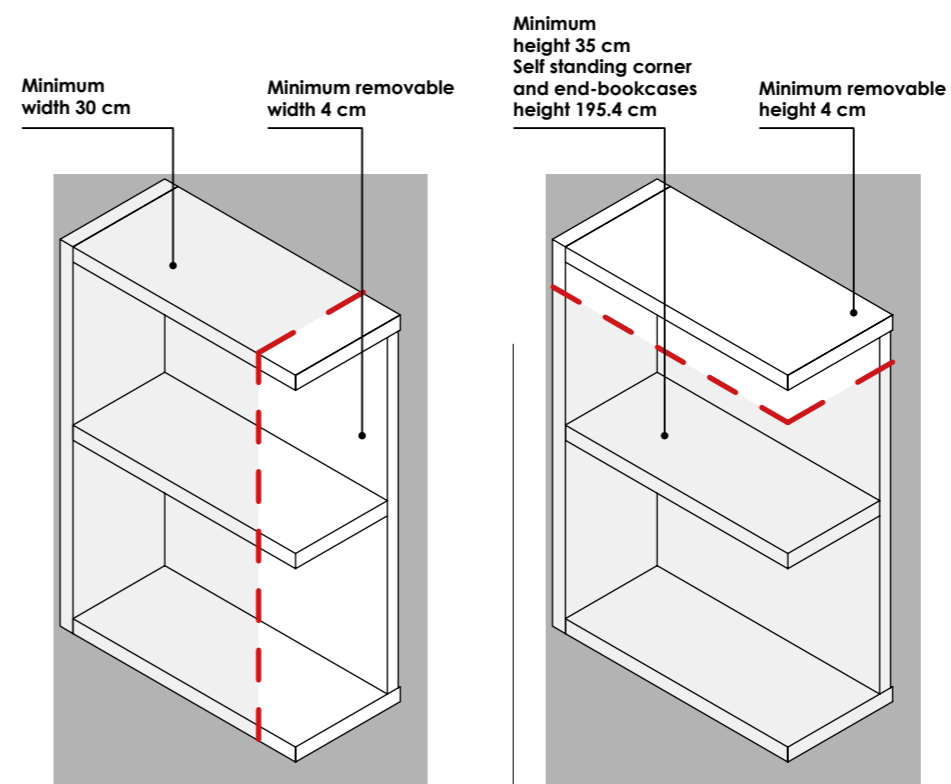

### WIDTH reduction

#### NOT POSSIBLE CUTS:

Metal and glass elements, drawers, WINDOW doors, folding doors, sliding doors, sliding door rails, DIVIDING PANELS, shaped end unit, full corner, TV compartments, beds save space CLICK and MAGIC modular units.

#### Example:

To reduce the width of the represented bookcase 4 components must be cut (top finishing insert, shelf, bottom panel and back panel), therefore the additional charge will be:  
35,00 x 4 = 140,00.

### HEIGHT reduction

#### NOT POSSIBLE CUTS:

Metal and glass elements, drawers, WINDOW doors, folding doors, sliding doors, sliding doors rail, DIVIDING PANELS, self standing bookcases maxi, TV compartments, beds save space CLICK and MAGIC modular units.

#### Notes:

Cuts are always made from top.  
No oblique cut.  
No structure height different from front height.

#### Example:

To reduce the width of the represented bookcase 2 components must be cut (side panel and back panel), therefore the additional charge will be:  
35,00 x 2 = 70,00.

### DEPTH reduction

NOT POSSIBLE





## W 30

Specify hinge  
R or L

Reference  
images →

Ht 32  
2 hinges

Ht 64  
2 hinges

Ht 96  
2 hinges

Ht 128  
3 hinges

Ht 160  
3 hinges

Ht 192  
4 hinges

Ht 224  
4 hinges

Ht 256  
4 hinges

Code	PL94.00F	PL94.01N	PL94.02U	PL94.03A		PL94.04G	PL94.05P	PL94.06V	PL94.07B		
ONE	matte										
	glossy										
CLUB											
WINDOW											

## W 45

Specify hinge  
R or L

Code	PL94.10M	PL94.11T	PL94.12Z	PL94.13F		PL94.14N	PL94.15U	PL94.16A	PL94.17G		
ONE	matte										
	glossy										
CLUB											
WINDOW											

## W 60

Specify hinge  
R or L

Code	PL94.20S	PL94.21Y	PL94.22E	PL94.23M		PL94.24T	PL94.25Z	PL94.26F	PL94.27N		
ONE	matte										
	glossy										
CLUB											
WINDOW											

\* Only one door  
is with handle

## W 90

Reference  
images →

Ht 32  
4 hinges

Ht 64  
4 hinges

Ht 96  
4 hinges

Ht 128  
6 hinges

Ht 160  
6 hinges

Ht 192  
8 hinges

Ht 224  
8 hinges

Ht 256  
8 hinges

Code	PL94.30X	PL94.31D	PL94.32L	PL94.33S		PL94.34Y	PL94.35E	PL94.36M	PL94.37T		
ONE	matte										
	glossy										
CLUB											
WINDOW											

Components in **Types and colors FRONT**

The doors are equipped with hinges decelerate.  
The doors are also available with push pull (not on CLUB and WINDOW).  
Upon request, the doors can be supplied without a handle and without handle holes (not on CLUB and WINDOW).  
Pairs of CLUB doors are provided only with one handle. Upon customer's request the CLUB handle can be mounted on both doors.



p. 56 Knob and handle positions

## INFINITY doors for full corner

Double door W 45

Reference images	Ht 32 4 hinges	Ht 64 4 hinges	Ht 96 4 hinges	Ht 128 6 hinges	Ht 160 6 hinges	Ht 192 8 hinges	Ht 224 8 hinges	Ht 256 8 hinges
<b>Code</b>	<b>PL94.40C</b>	<b>PL94.41K</b>	<b>PL94.42R</b>	<b>PL94.43X</b>	<b>PL94.44D</b>	<b>PL94.45L</b>	<b>PL94.46S</b>	<b>PL94.47Y</b>
ONE	matte							
	glossy							
CLUB								

## INFINITY doors vasistas and folding Ht 32

Reference images		
<b>W 45</b>	<b>Code</b>	<b>PK84.00A</b> <b>PK84.01G</b>
	ONE	matte
		glossy
	CLUB	
<b>W 60</b>	<b>Code</b>	<b>PK84.02P</b> <b>PK84.03V</b>
	ONE	matte
		glossy
	CLUB	
<b>W 90</b>	<b>Code</b>	<b>PK84.04B</b> <b>PK84.05H</b>
	ONE	matte
		glossy
	CLUB	
<b>W 120</b>	<b>Code</b>	<b>PK84.06Q</b> <b>PK84.07W</b>
	ONE	matte
		glossy
	CLUB	

Top and bottom hinged doors W 90 and 120 can be mounted also on 2 juxtaposed elements exclusively as indicated in the example.

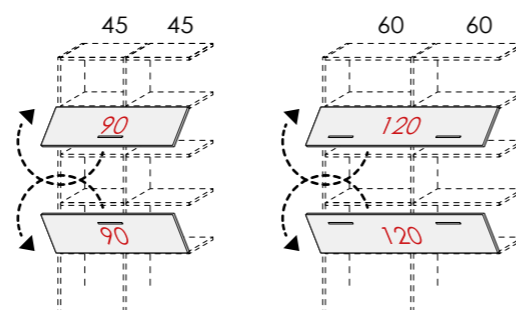

**\* WARNING:**  
For a correct operation of folding and vasistas system, follow the instructions below.

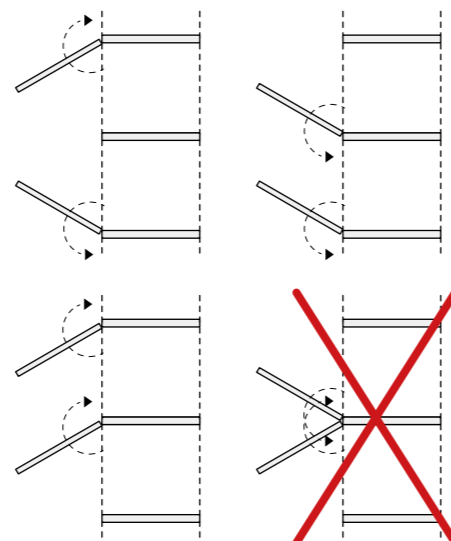

## Drawers INFINITY

+ 9,00 for cylinder lock (only on the first drawer at the top - not on CLUB fronts).

Reference images	Dpt 29.3			Dpt 41.8		
	1 drawer Ht 16	2 drawers Ht 16	4 drawers Ht 16	1 drawer Ht 16	2 drawers Ht 16	4 drawers Ht 16
<b>W 45</b>	<b>Code</b>	<b>PL94.86P</b>	<b>PL94.87V</b>	<b>PL94.88B</b>	<b>PK83.80Q</b>	<b>PK83.81W</b> <b>PK83.82C</b>
	ONE	matte				
		glossy				
	CLUB					
<b>W 60</b>	<b>Code</b>	<b>PL94.89H</b>	<b>PL94.90E</b>	<b>PL94.91M</b>	<b>PK83.83K</b>	<b>PK83.84R</b> <b>PK83.85X</b>
	ONE	matte				
		glossy				
	CLUB					
<b>W 90</b>	<b>Code</b>	<b>PL94.92T</b>	<b>PL94.93Z</b>	<b>PL94.94F</b>	<b>PK83.86D</b>	<b>PK83.87L</b> <b>PK83.88S</b>
	ONE	matte				
		glossy				
	CLUB					

## Inside drawers INFINITY

Cannot be used in the presence of a skirting board recess

Reference images	Dpt 29.3		Dpt 41.8	
	2 drawers Ht 16		2 drawers Ht 16	
<b>W 45</b>	<b>Code</b>	<b>PL94.95N</b>	<b>PK83.89Y</b>	
<b>W 60</b>	<b>Code</b>	<b>PL94.96U</b>	<b>PK83.90V</b>	
<b>W 90</b>	<b>Code</b>	<b>PL94.97A</b>	<b>PK83.91B</b>	

Components in **Types and colors FRONT**  
Components in **GROUP 2 colors**

The vasistas/folding doors are provided with concealed hinges.  
The vasistas/folding doors can be supplied with push pull system.  
Drawers are provided with slowed down "Quadro" metal runners which have adjustable height with interior CHARM finish.  
The internal drawers can be positioned in correspondence with open compartments and sliding doors with back panel.

CLUB  
drawers and large drawers  
CHARM with "Quadro" type  
soft rails as standard  
(without surcharges)

# Sliding doors INFINITY

- Track must be always mounted on an horizontal line of shelves, top finishing insert or bottom panel, at any height.
- The track always covers half of the first vertical panel and half of the second (track length = bookcase length - 2.5 cm).
- The compartments behind sliding doors may be equipped with inside drawers.
- It is possible to overlap even sliding doors with different sizes.
- You can mount front panels on the compartments at the left or right of the sliding tracks.
- Customized cuts are not available.

## SINGLE DOOR EXAMPLE

Order 2 complete sliding tracks.

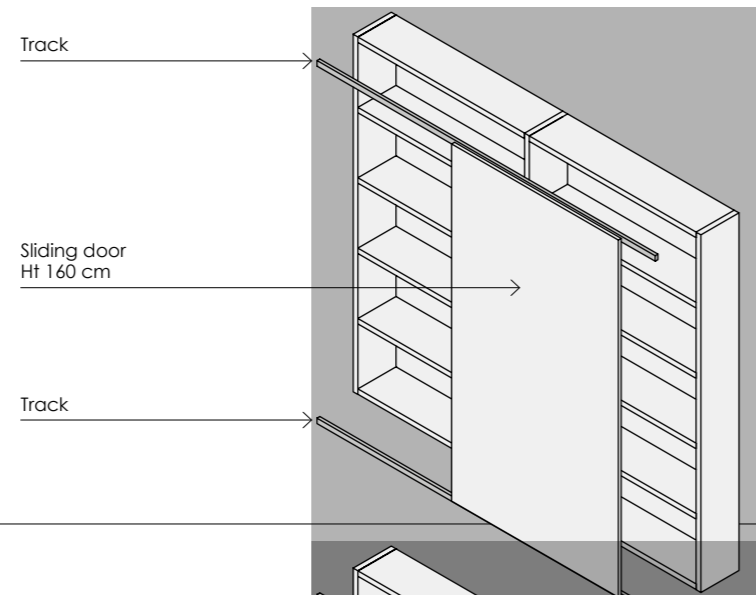

## MULTIPLE DOORS EXAMPLE

The number of tracks you order is equal to the number of doors + 1.

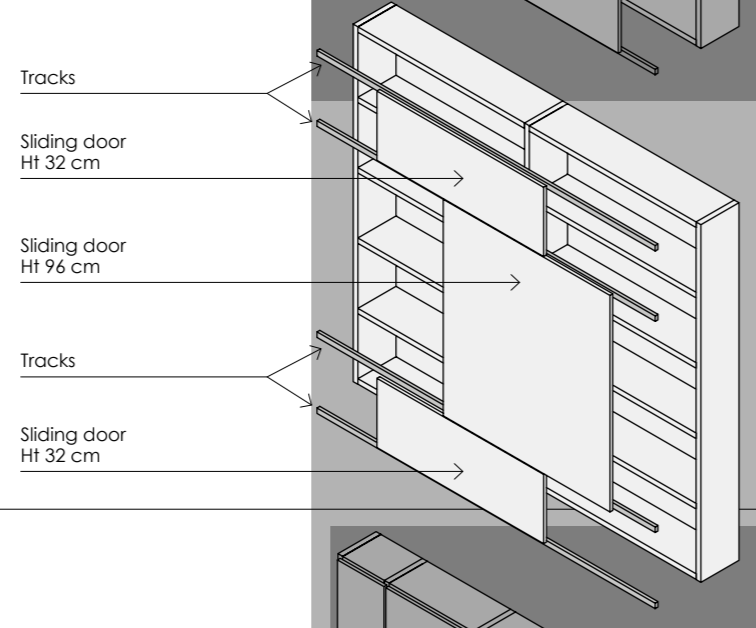

## MIXED DOORS EXAMPLE

It is possible to juxtapose sliding doors with other types of front panels. Other front panels can not be assembled on the compartment above and the one below the track (✘).

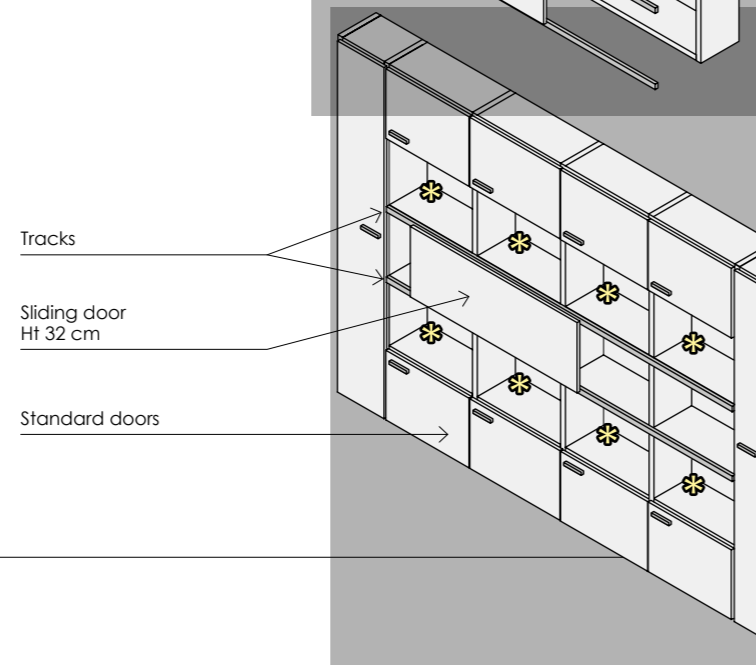

Components in GROUP 2 colors

## Tracks

Th 1.5 cm

Colours available:



	180	240	270	300	360	
Code	PL93.83Q	PL93.84W	PL93.85C	PL93.99K	PL93.86K	

## Melamine-faced doors

Supplied with soft open/close system.  
Door thickness 2.5. Track + door thickness 3.1 cm.  
The bookcases depth, considering doors is 36.4/48.9 cm.

### W 90

	32	96	160			
Code	PL93.87R	PL93.88X	PL93.89D			

### W 120

	32	96	160			
Code	PL93.90A	PL93.91G	PL93.92P			

## Aluminium frame doors

Supplied with soft open/close system.  
Door thickness 2. Track + door thickness 2.8 cm.  
The bookcases depth, considering doors is 36.1/48.6 cm.  
Tempered glass Th 0.4.

Colours available:



### W 90

	32	96	160			
Code	PL93.93V	PL93.94B	PL93.95H			

### W 120

	32	96	160			
Code	PL93.96Q	PL93.97W	PL93.98C			

GROUP 1 colors	Rovere Dorian RD5T	Rovere white RW3Q	Noce naturale NN7H	Eucalipto CL1X	Domy DM7P	Bianco UV BU3Q
	Ciliegio bianco CB6K	Malta ML7H	Feltro FL8X	Cemento Masdar CM3Q	Blu indaco BI4B	
	Noce NC4B	Desert DS9L	Canapa CN1X	Moka MK6B	Cipria CP4J	
	Bianco opaco BI7A	Grigio Dorian GL4R	Basalto BS5T	Grigio titanio GZ8T	Rosa bubble RB7Y	
GROUP 2 colors	Agave GV7A	Verde Alpi VA5T	Cadaques CQ3Q	Giallo zafferano GZ8A	Corallo CR5T	
	Blu opale BO7H					
GROUP 3 colors						
CARCASE colors						

Types and colors FRONT	ONE	Rovere white RW3Q	Rovere Dorian RD5T	Ciliegio bianco CB6K	Noce naturale NN7H	Noce NC4B	Eucalipto CL1X	Malta ML7H
		Feltro FL8X	Cemento Masdar CM3Q	Bianco opaco BI7A	Desert DS9L	Canapa CN1X	Moka MK6B	Grigio Dorian GL4R
	CLUB	Basalto BS5T	Grigio titanio GZ8T	Domy DM7P	Agave GV7A	Verde Alpi VA5T	Cadaques CQ3Q	Blu indaco BI4B
		Blu opale BO7H	Cipria CP4J	Rosa bubble RB7Y	Giallo zafferano GZ8A	Corallo CR5T		
	WINDOW	Specify the color of the CLUB handle						
		Bianco opaco BI7A	Desert DS9L	Canapa CN1X	Moka MK6B	Grigio Dorian GL4R	Basalto BS5T	Grigio titanio GZ8T
		Domy DM7P	Agave GV7A	Verde Alpi VA5T	Cadaques CQ3Q	Blu indaco BI4B	Blu opale BO7H	Cipria CP4J
		Rosa bubble RB7Y	Giallo zafferano GZ8A	Corallo CR5T				
		Specify the color of the aluminum frame						
		Alluminio AL1A	Titan grey TG7H					

**INFINITY bookcases - Self standing**

Self standing bookcases Dpt 33.3 - Dimensions	740
Self standing bookcases Dpt 33.3 - Linear assembling	742
Self standing bookcases Dpt 33.3	744
Self standing bookcases Dpt 33.3 - Ht 195.3	746
Self standing bookcases Dpt 33.3 - Ht 227.3	748
Self standing bookcases Dpt 33.3 - Ht 259.3	750
Self standing bookcases maxi Dpt 33.3	752
Self standing bookcases maxi Dpt 33.3 - Dividing panels	754
Self standing bookcases Dpt 33.3 - Semi-suspended	756
Self standing corner bookcases Dpt 33.3 - Full corner	764
Self standing end-bookcases Dpt 33.3	765
Self standing bookcases Dpt 33.3 - For passage	766
Floor boiserie	768
Semi-suspended boiserie	770
Self standing bookcases Dpt 33.3 - With desk	772
Self standing bookcases Dpt 33.3 - With peninsula	774
Self standing bookcases Dpt 33.3 - With TV compartment	776
Self standing bookcases Dpt 33.3 - With 180° rotating TV compartment	778
Self standing bookcases Dpt 33.3 - With CLICK foldaway beds W 80 base	780
Self standing bookcases Dpt 33.3 - With CLICK foldaway beds W 120 base	782
Self standing bookcases Dpt 33.3 - With CLICK foldaway beds W 140 base	783
Self standing bookcases Dpt 33.3 - With CLICK foldaway beds W 160 base - (A)	784
Self standing bookcases Dpt 33.3 - With CLICK foldaway beds W 160 base - (B)	788
Self standing bookcases Dpt 45.8 - Dimensions	790
Self standing bookcases Dpt 45.8 - Linear assembling	791
Self standing bookcases Dpt 45.8	792
Self standing bookcases Dpt 45.8 - Ht 195.3	794
Self standing bookcases Dpt 45.8 - Ht 227.3	796
Self standing bookcases Dpt 45.8 - Ht 259.3	798
Self standing corner bookcases Dpt 45.8 - Full corner	800
Self standing end-bookcases Dpt 45.8	801
Self standing bookcases Dpt 45.8 - For passage	802
Self standing bookcases Dpt 45.8 - With peninsula	804
Self standing bookcases Dpt 45.8 - With TV compartment	806

# Self standing bookcases Dpt 33.3 - Dimensions

## WIDTH AND DEPTH

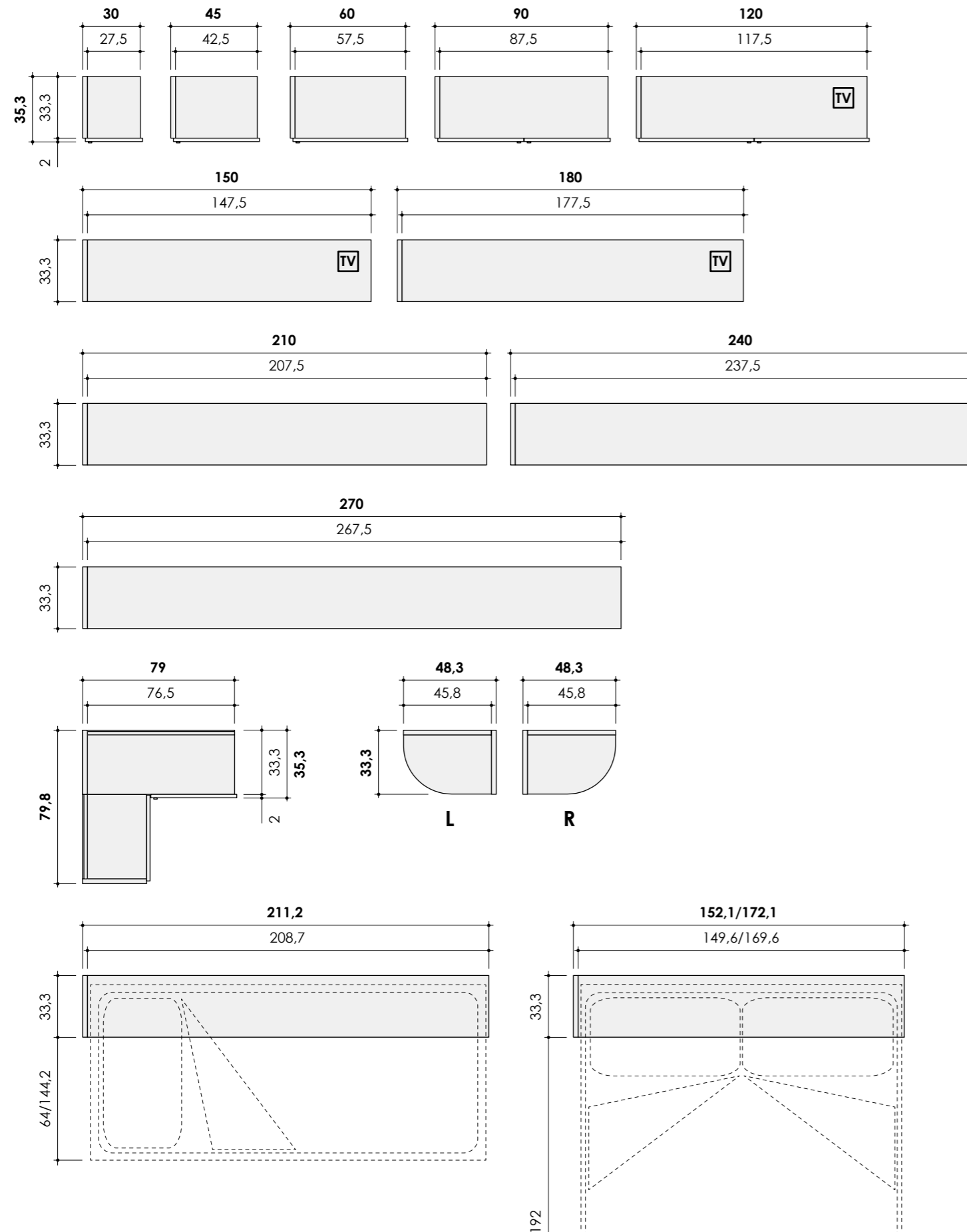

Also with TV compartment

## HEIGHT

The standard distance between each shelf is 32 cm. Upon request, shelves can be positioned every 16 cm.

The last counter-opposing housing space cannot be equipped with a back panel and doors.

## SELF STANDING BOOKCASES

With top and top finishing insert. Ht 0.8 cm adjustable foot included in heights.

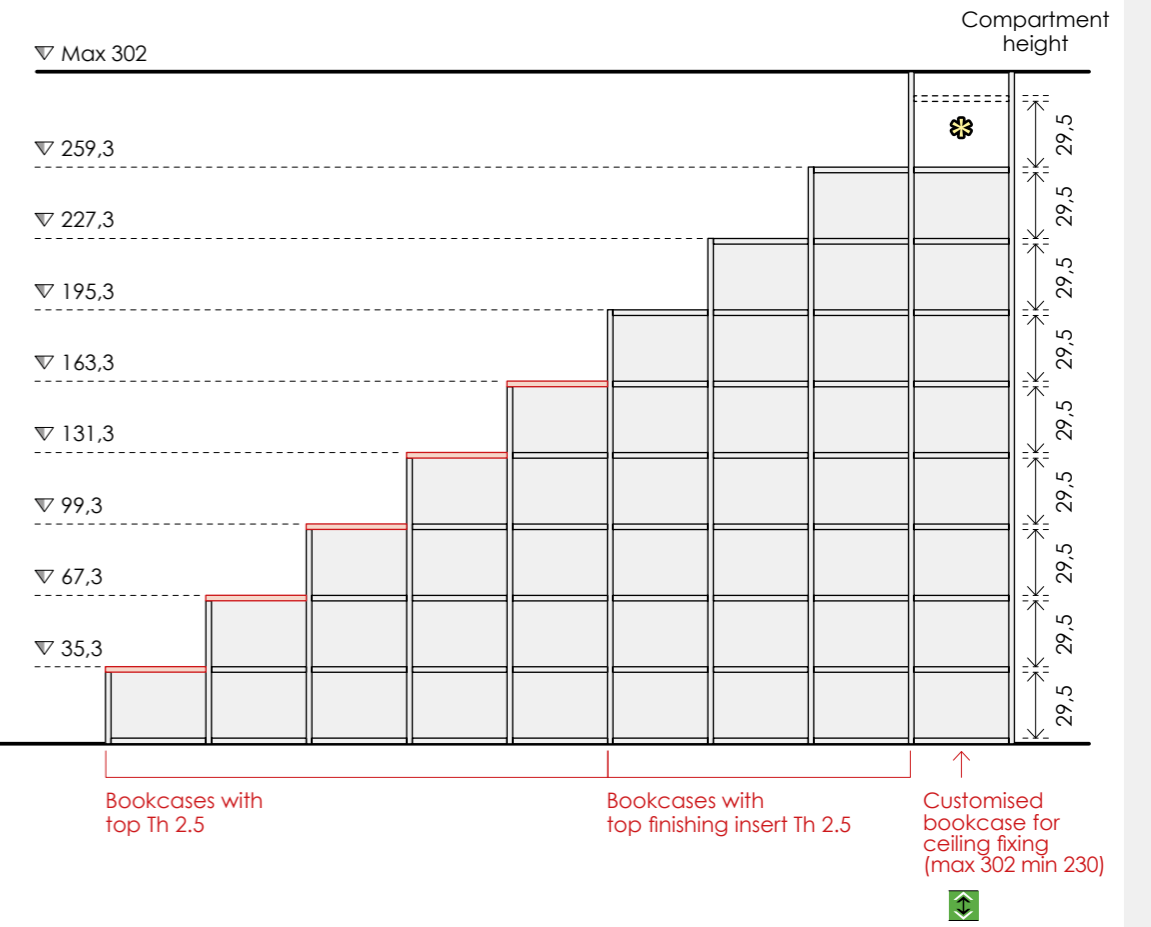

The side panel is equipped with adjustable feet (top and bottom) for fixing between floor and ceiling which allow a maximum adjustment of 20 mm. **When ordering it is necessary to indicate the room height (floor-ceiling); the bookcase will be adjusted to size according to the distance detected.** We recommend that you check the room height in more than one point in order to find any excessive differences. With false ceilings you should check that in the event of inflection, the height difference does not exceed the 2 cm maximum adjustable range of the feet.

# Self standing bookcases Dpt 33.3 - Linear assembling

## SOME COMPOSITION EXAMPLES

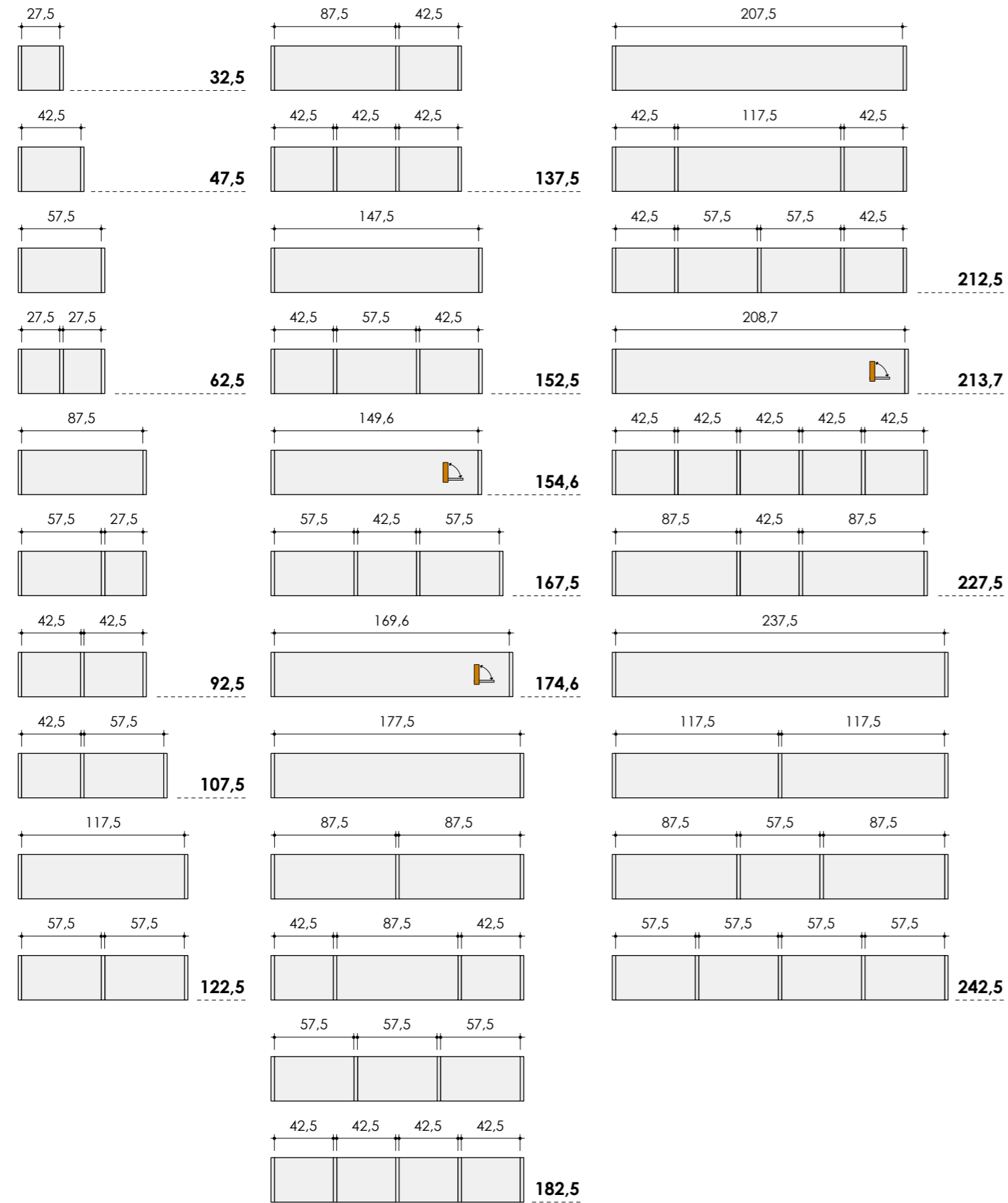

Module with save space CLICK



# Self standing bookcases Dpt 33.3

With back panel

\*  
To be completed with Top Th 2.5

W 30	Code	PL85.00G	PL85.01P	PL85.02V	PL85.03B	PL85.04H	PL85.05Q	PL85.06W	PL85.07C		
W 45	Code	PL85.08K	PL85.09R	PL85.10N	PL85.11U	PL85.12A	PL85.13G	PL85.14P	PL85.15V		PL99.03X
W 60	Code	PL85.16B	PL85.17H	PL85.18Q	PL85.19W	PL85.20T	PL85.21Z	PL85.22F	PL85.23N		PL99.04D
W 90	Code	PL85.24U	PL85.25A	PL85.26G	PL85.27P	PL85.28V	PL85.29B	PL85.30Y	PL85.31E		PL99.05L
											PL99.06S

Customised bookcase for ceiling fixing.  
Ht room (Max 302 Min 230)

Movable shelves

W 27.5	Code	Melamine-coated Th 2,5		In transparent tempered glass Th 0,8		
		Dpt 30.8	Dpt 33.3	Dpt 29.8 with led	Dpt 28.5	Dpt 28.5 with led
W 42.5	Code	PL86.00M	PL86.01T	-	-	-
W 57.5	Code	PL86.02Z	PL86.03F	PL86.04N	PL86.05U	PL86.06A
W 87.5	Code	PL86.07G	PL86.08P	PL86.09V	PL86.10S	PL86.11Y
	Code	PL86.12E	PL86.13M	PL86.14T	PL86.15Z	PL86.16F

Two-sided see-through units

\*  
To be completed with Top Th 2.5

W 30	Code	PL85.32M	PL85.33T	PL85.34Z	PL85.35F	PL85.36N	PL85.37U	PL85.38A	PL85.39G		
W 45	Code	PL85.40D	PL85.41L	PL85.42S	PL85.43Y	PL85.44E	PL85.45M	PL85.46T	PL85.47Z		PL99.07Y
W 60	Code	PL85.48F	PL85.49N	PL85.50K	PL85.51R	PL85.52X	PL85.53D	PL85.54L	PL85.55S		PL99.08E
W 90	Code	PL85.56Y	PL85.57E	PL85.58M	PL85.59T	PL85.60Q	PL85.61W	PL85.62C	PL85.63K		PL99.09M
											PL99.10H

Customised bookcase for ceiling fixing.  
Ht room (Max 302 Min 230)

**led spotlights Ø 6.5**  
We provide a power pack (with a surcharge) able to support from 1 to 6 spotlights. 12 volt 1.7 watt.

**Wireless switch**  
For led lighting (usable for shelves and for spotlight).

	Code	PL86.17N	PL86.18U	
--	------	----------	----------	--

\*  
**Top Dpt 33.3 - Th 2.5**  
**Max W 360 - Min W 30**  
per linear metre

	Standard top	Top with side fixings	Top with right side fixings	Top with left side fixings
Code	PL86.20X	PL86.21D	PL86.22L	PL86.23S

Backs Th 1.8

W 30	Code	PL85.64R	PL85.65X	PL85.66D	PL85.67L	PL85.68S	PL85.69Y	PL85.70V	PL85.71B
W 45	Code	PL85.72H	PL85.73Q	PL85.74W	PL85.75C	PL85.76K	PL85.77R	PL85.78X	PL85.79D
W 60	Code	PL85.80A	PL85.81G	PL85.82P	PL85.83V	PL85.84B	PL85.85H	PL85.86Q	PL85.87W
W 90	Code	PL85.88C	PL85.89K	PL85.90F	PL85.91N	PL85.92U	PL85.93A	PL85.94G	PL85.95P

**Side panels on floor**  
**Dpt 33.3 - Th 2.5**  
(Ht 0.8 foot not included)

Code	PL86.24Y	PL86.25E	PL86.26M	PL86.27T	PL86.28Z	PL86.29F	PL86.30C	PL86.31K	PL85.96V

Customised side panel for ceiling fixing  
Ht room (Max 302 Min 230)

☑ We provide a power pack (with a surcharge) able to support from 1 to 6 shelves W 45/60 or from 1 to 4 shelves W 90

- ☐ Components in **GROUP 2 colors**
- Ⓐ For bookcases with back
- Ⓑ For see-through/two-sided bookcases

⬇ The side panel is equipped with adjustable feet (top and bottom) for fixing between floor and ceiling which allow a maximum adjustment of 20 mm. **When ordering it is necessary to indicate the room height (floor-ceiling); the bookcase will be adjusted to size according to the distance detected.** We recommend that you check the room height in more than one point in order to find any excessive differences. With false ceilings you should check that in the event of inflection, the height difference does not exceed the 2 cm maximum adjustable range of the feet.

- 👉 p. 732 Doors INFINITY
- 👉 p. 735 Drawers INFINITY
- 👉 p. 736 Sliding doors INFINITY

# Self standing bookcases Dpt 33.3 - Ht 195.3

With back panel

See-through

## W 30

Specify hinge R or L

Reference images →

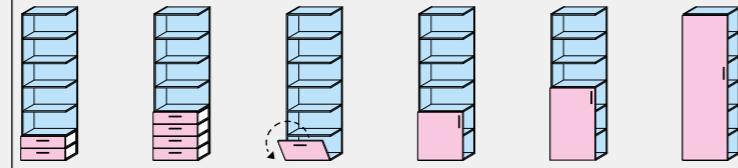

<b>Code</b>	-	-	-	PL80.10R	PL80.11X	PL80.12D								
ONE	matte													
	glossy													
CLUB														
WINDOW														

## W 45

Specify hinge R or L

<b>Code</b>	PL80.15Y	PL80.16E	PK84.10F	PL80.18T	PL80.19Z	PL80.20W							PL80.44H	PL80.45Q	PK84.13A	PL80.47C	PL80.48K	
ONE	matte																	
	glossy																	
CLUB																		
WINDOW																		

## W 60

Specify hinge R or L

<b>Code</b>	PL80.23R	PL80.24X	PK84.11N	PL80.26L	PL80.27S	PL80.28Y								PL80.51U	PL80.52A	PK84.14G	PL80.54P	PL80.55V	
ONE	matte																		
	glossy																		
CLUB																			
WINDOW																			

## W 90

Reference images →

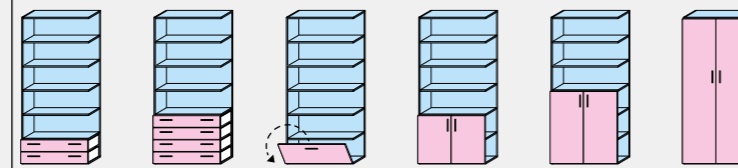

<b>Code</b>	PL80.31H	PL80.32Q	PK84.12U	PL80.34C	PL80.35K	PL80.36R													
ONE	matte																		
	glossy																		
CLUB																			
WINDOW																			

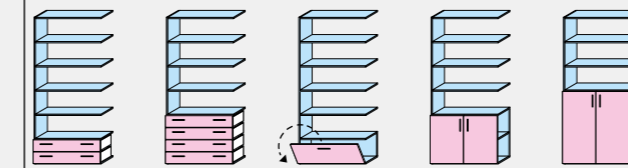

<b>Code</b>	PL80.58Q	PL80.59W	PK84.15P	PL80.61Z	PL80.62F
ONE	matte				
	glossy				
CLUB					
WINDOW					

### Movable shelves

Melamine-coated Th 2,5

Dpt 30.8

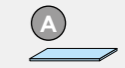

Dpt 33.3

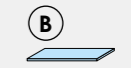

Dpt 29.8 with led



<b>W 27.5</b>	<b>Code</b>	PL86.00M	PL86.01T	-
<b>W 42.5</b>	<b>Code</b>	PL86.02Z	PL86.03F	PL86.04N
<b>W 57.5</b>	<b>Code</b>	PL86.07G	PL86.08P	PL86.09V
<b>W 87.5</b>	<b>Code</b>	PL86.12E	PL86.13M	PL86.14T

In transparent tempered glass Th 0,8

Dpt 28.5

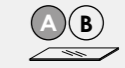

Dpt 28.5 with led



<b>W 27.5</b>	<b>Code</b>	-	-
<b>W 42.5</b>	<b>Code</b>	PL86.05U	PL86.06A
<b>W 57.5</b>	<b>Code</b>	PL86.10S	PL86.11Y
<b>W 87.5</b>	<b>Code</b>	PL86.15Z	PL86.16F

**led spotlights Ø 6.5**  
We provide a power pack (with a surcharge) able to support from 1 to 6 spotlights. 12 volt 1.7 watt.



<b>Code</b>	PL86.17N
-------------	----------

**Wireless switch**  
For led lighting (usable for shelves and for spotlight).



<b>Code</b>	PL86.18U
-------------	----------

### Side panel on floor Dpt 33.3 - Th 2.5

(Ht 0.8 foot not included)

Ht 194.5



<b>Code</b>	PL86.29F
-------------	----------

- Components in **GROUP 2 colors**
- Components in **Types and colors FRONT**
- A** For bookcases with back
- B** For see-through bookcases

We provide a power pack (with a surcharge) able to support from 1 to 6 shelves W 45/60 or from 1 to 4 shelves W 90

**p. 56** Knob and handle positions  
**p. 732** Doors INFINITY  
**p. 735** Drawers INFINITY

**p. 736** Sliding doors INFINITY

# Self standing bookcases Dpt 33.3 - Ht 227.3

With back panel

See-through

## W 30

Specify hinge R or L

Reference images →

<b>Code</b>	-	-	-	PL81.12H	PL81.13Q	PL81.14W				-	-	-	PL81.41T	PL81.42Z			
ONE	matte																
	glossy																
CLUB																	
WINDOW																	

## W 45

Specify hinge R or L

<b>Code</b>	PL81.17R	PL81.18X	PK84.16V	PL81.20A	PL81.21G	PL81.22P							PL81.45U	PL81.46A	PK84.19Q	PL81.48P	PL81.49V
ONE	matte																
	glossy																
CLUB																	
WINDOW																	

## W 60

Specify hinge R or L

<b>Code</b>	PL81.25H	PL81.26Q	PK84.17B	PL81.28C	PL81.29K	PL81.30F							PL81.52E	PL81.53M	PK84.20M	PL81.55Z	PL81.56F
ONE	matte																
	glossy																
CLUB																	
WINDOW																	

## W 90

Reference images →

<b>Code</b>	PL81.33A	PL81.34G	PK84.18H	PL81.36V	PL81.37B	PL81.38H							PL81.59A	PL81.60X	PK84.21T	PL81.62L	PL81.63S
ONE	matte																
	glossy																
CLUB																	
WINDOW																	

### Movable shelves

Melamine-coated Th 2,5

Dpt 30.8

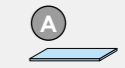

Dpt 33.3

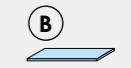

Dpt 29.8 with led



W 27.5	<b>Code</b>	PL86.00M	PL86.01T	-
W 42.5	<b>Code</b>	PL86.02Z	PL86.03F	PL86.04N
W 57.5	<b>Code</b>	PL86.07G	PL86.08P	PL86.09V
W 87.5	<b>Code</b>	PL86.12E	PL86.13M	PL86.14T

In transparent tempered glass Th 0,8

Dpt 28.5

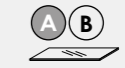

Dpt 28.5 with led



W 27.5	<b>Code</b>	-	-	
W 42.5	<b>Code</b>	PL86.05U	PL86.06A	
W 57.5	<b>Code</b>	PL86.10S	PL86.11Y	
W 87.5	<b>Code</b>	PL86.15Z	PL86.16F	

led spotlights Ø 6.5  
We provide a power pack (with a surcharge) able to support from 1 to 6 spotlights. 12 volt 1.7 watt.



<b>Code</b>	PL86.17N
-------------	----------

Wireless switch  
For led lighting (usable for shelves and for spotlight).

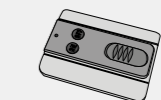

<b>Code</b>	PL86.18U
-------------	----------

### Side panel on floor Dpt 33.3 - Th 2.5

(Ht 0.8 foot not included)

Customised side panel for ceiling fixing  
Ht room (Max 302 Min 230)

Ht 226.5

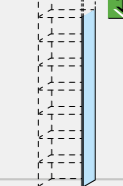
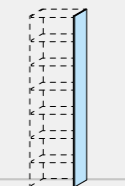

<b>Code</b>	PL86.30C	PL85.96V
-------------	----------	----------

- Components in **GROUP 2 colors**
- Components in **Types and colors FRONT**
- A For bookcases with back
- B For see-through bookcases

The side panel is equipped with adjustable feet (top and bottom) for fixing between floor and ceiling which allow a maximum adjustment of 20 mm. **When ordering it is necessary to indicate the room height (floor-ceiling); the bookcase will be adjusted to size according to the distance detected.** We recommend that you check the room height in more than one point in order to find any excessive differences. With false ceilings you should check that in the event of inflection, the height difference does not exceed the 2 cm maximum adjustable range of the feet.

We provide a power pack (with a surcharge) able to support from 1 to 6 shelves W 45/60 or from 1 to 4 shelves W 90

p. 56 Knob and handle positions  
p. 732 Doors INFINITY  
p. 735 Drawers INFINITY

p. 736 Sliding doors INFINITY

# Self standing bookcases Dpt 33.3 - Ht 259.3

With back panel

See-through

## W 30

Specify hinge R or L

Reference images →

<b>Code</b>	-	-	-	PL82.10Z	PL82.11F	PL82.12N				-	-	-	PL82.40R	PL82.41X
ONE	matte													
	glossy													
CLUB														
WINDOW														

## W 45

Specify hinge R or L

<b>Code</b>	PL82.15G	PL82.16P	PK84.22Z	PL82.18B	PL82.19H	PL82.20E				PL82.44S	PL82.45Y	PK84.25U	PL82.47M	PL82.48T
ONE	matte													
	glossy													
CLUB														
WINDOW														

## W 60

Specify hinge R or L

<b>Code</b>	PL82.23Z	PL82.24F	PK84.23F	PL82.26U	PL82.27A	PL82.28G				PL82.51C	PL82.52K	PK84.26A	PL82.54X	PL82.55D
ONE	matte													
	glossy													
CLUB														
WINDOW														

## W 90

Reference images →

<b>Code</b>	PL82.31S	PL82.32Y	PK84.24N	PL82.34M	PL82.35T	PL82.36Z				PL82.58Y	PL82.59E	PK84.27G	PL82.61H	PL82.62Q
ONE	matte													
	glossy													
CLUB														
WINDOW														

### Movable shelves

Melamine-coated Th 2,5

Dpt 30.8

Dpt 33.3

Dpt 29.8 with led



W 27.5	<b>Code</b>	PL86.00M	PL86.01T	-
W 42.5	<b>Code</b>	PL86.02Z	PL86.03F	PL86.04N
W 57.5	<b>Code</b>	PL86.07G	PL86.08P	PL86.09V
W 87.5	<b>Code</b>	PL86.12E	PL86.13M	PL86.14T

In transparent tempered glass Th 0,8

Dpt 28.5

Dpt 28.5 with led



W 27.5	<b>Code</b>	-	-
W 42.5	<b>Code</b>	PL86.05U	PL86.06A
W 57.5	<b>Code</b>	PL86.10S	PL86.11Y
W 87.5	<b>Code</b>	PL86.15Z	PL86.16F

**led spotlights Ø 6.5**  
We provide a power pack (with a surcharge) able to support from 1 to 6 spotlights. 12 volt 1.7 watt.

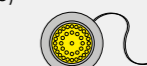

<b>Code</b>	PL86.17N
-------------	----------

**Wireless switch**  
For led lighting (usable for shelves and for spotlight).



<b>Code</b>	PL86.18U
-------------	----------

### Side panel on floor Dpt 33.3 - Th 2.5

(Ht 0.8 foot not included)

Customised side panel for ceiling fixing  
Ht room (Max 302 Min 230)

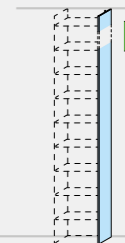
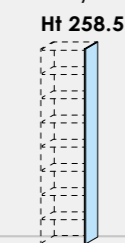

<b>Code</b>	PL86.31K	PL85.96V
-------------	----------	----------

- Components in **GROUP 2 colors**
- Components in **Types and colors FRONT**
- A For bookcases with back
- B For see-through bookcases

⚠ The side panel is equipped with adjustable feet (top and bottom) for fixing between floor and ceiling which allow a maximum adjustment of 20 mm. **When ordering it is necessary to indicate the room height (floor-ceiling); the bookcase will be adjusted to size according to the distance detected.** We recommend that you check the room height in more than one point in order to find any excessive differences. With false ceilings you should check that in the event of inflection, the height difference does not exceed the 2 cm maximum adjustable range of the feet.

⚠ We provide a power pack (with a surcharge) able to support from 1 to 6 shelves W 45/60 or from 1 to 4 shelves W 90

p. 56 Knob and handle positions  
p. 732 Doors INFINITY  
p. 735 Drawers INFINITY

p. 736 Sliding doors INFINITY

# Self standing bookcases maxi Dpt 33.3

With back panel

\*  
To be completed with Top Th 2.5

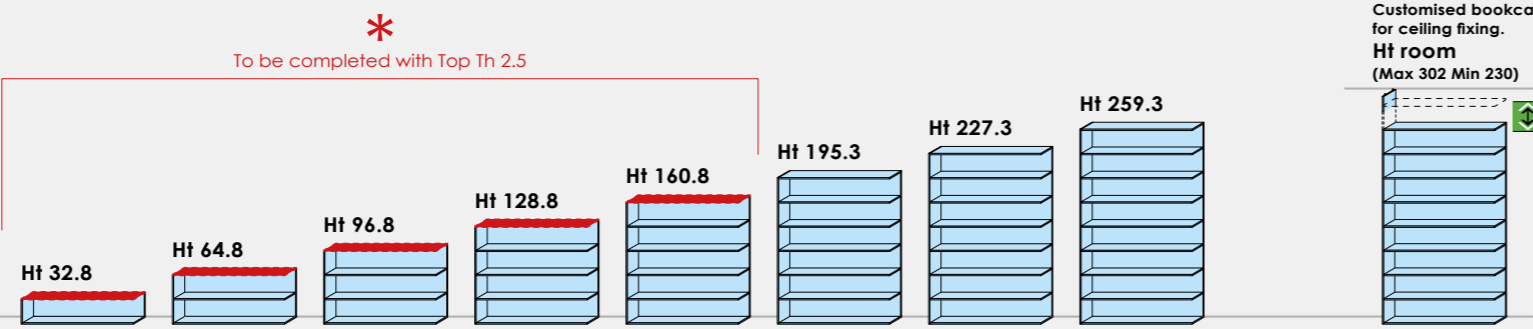

W 120	Code	PL86.50P	PL86.51V	PL86.52B	PL86.53H	PL86.54Q	PL86.55W	PL86.56C	PL86.57K	PL99.11Q
W 150	Code	PL86.58R	PL86.59X	PL86.60U	PL86.61A	PL86.62G	PL86.63P	PL86.64V	PL86.65B	PL99.12W
W 180	Code	PL86.66H	PL86.67Q	PL86.68W	PL86.69C	PL86.70Z	PL86.71F	PL86.72N	PL86.73U	PL99.13C
W 210	Code	PL86.74A	PL86.75G	PL86.76P	PL86.77V	PL86.78B	PL86.79H	PL86.80E	PL86.81M	PL99.14K
W 240	Code	PL86.82T	PL86.83Z	PL86.84F	PL86.85N	PL86.86U	PL86.87A	PL86.88G	PL86.89P	PL99.15R
W 270	Code	PL86.90L	PL86.91S	PL86.92Y	PL86.93E	PL86.94M	PL86.95T	PL86.96Z	PL86.97F	PL99.16X

Backs  
Th 1.8

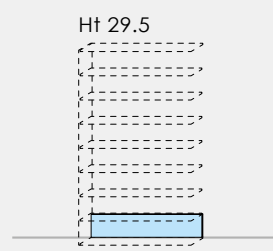

W 117.5	Code	PL87.50T
W 147.5	Code	PL87.51Z
W 177.5	Code	PL87.52F
W 207.5	Code	PL87.53N
W 237.5	Code	PL87.54U
W 267.5	Code	PL87.55A

### IMPORTANT:

Bookcases proposed in these pages must be completed with dividing panels with load-bearing function.

Consult following pages for codes and application.

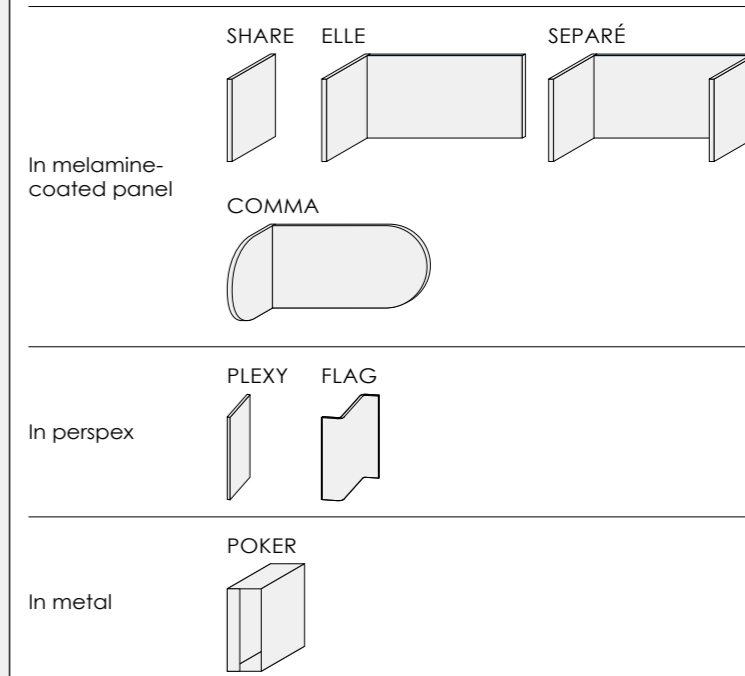

Two-sided see-through units

\*  
Top Dpt 33.3 - Th 2.5  
Max W 360 - Min W 30  
per linear metre

\*  
To be completed with Top Th 2.5

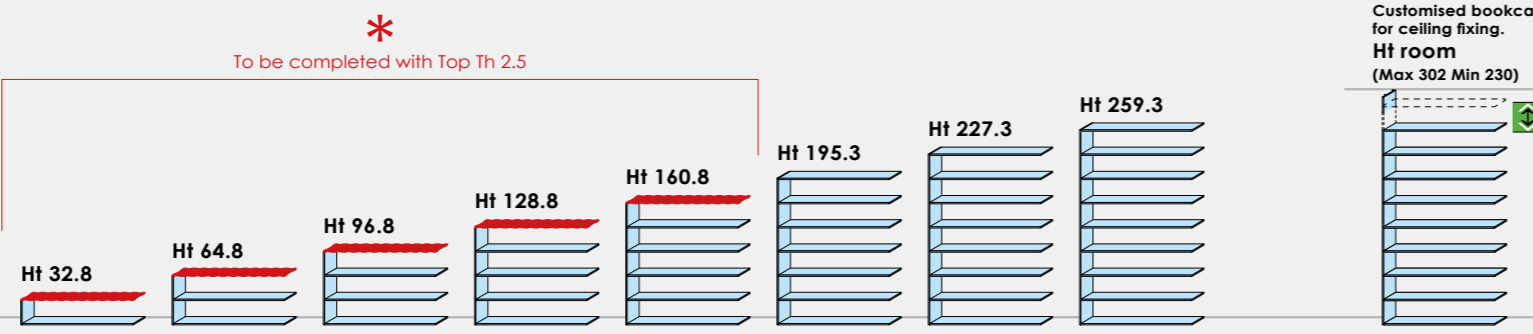

W 120	Code	PL87.00R	PL87.01X	PL87.02D	PL87.03L	PL87.04S	PL87.05Y	PL87.06E	PL87.07M	PL99.17D
W 150	Code	PL87.08T	PL87.09Z	PL87.10W	PL87.11C	PL87.12K	PL87.13R	PL87.14X	PL87.15D	PL99.18L
W 180	Code	PL87.16L	PL87.17S	PL87.18Y	PL87.19E	PL87.20B	PL87.21H	PL87.22Q	PL87.23W	PL99.19S
W 210	Code	PL87.24C	PL87.25K	PL87.26R	PL87.27X	PL87.28D	PL87.29L	PL87.30G	PL87.31P	PL99.20P
W 240	Code	PL87.32V	PL87.33B	PL87.34H	PL87.35Q	PL87.36W	PL87.37C	PL87.38K	PL87.39R	PL99.21V
W 270	Code	PL87.40N	PL87.41U	PL87.42A	PL87.43G	PL87.44P	PL87.45V	PL87.46B	PL87.47H	PL99.22B

\*  
Customised bookcase for ceiling fixing.  
Ht room (Max 302 Min 230)

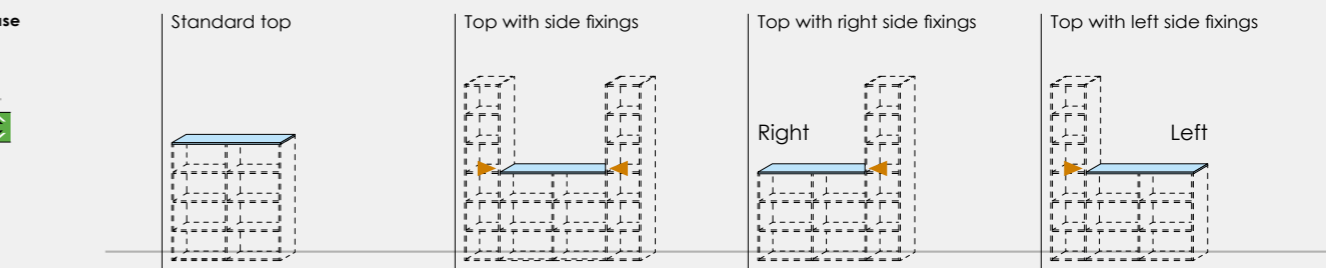

Code	PL86.20X	PL86.21D	PL86.22L	PL86.23S
------	----------	----------	----------	----------

Side panels on floor  
Dpt 33.3 - Th 2.5  
(Ht 0.8 foot not included)

\*  
Customised side panel for ceiling fixing  
Ht room (Max 302 Min 230)

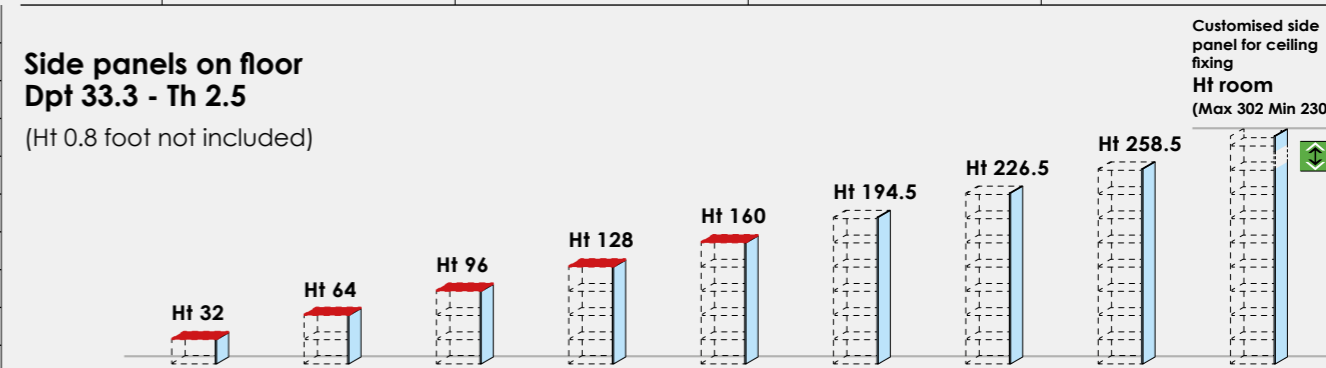

Code	PL86.24Y	PL86.25E	PL86.26M	PL86.27T	PL86.28Z	PL86.29F	PL86.30C	PL86.31K	PL85.96V
------	----------	----------	----------	----------	----------	----------	----------	----------	----------

Components in GROUP 2 colors

The side panel is equipped with adjustable feet (top and bottom) for fixing between floor and ceiling which allow a maximum adjustment of 20 mm. **When ordering it is necessary to indicate the room height (floor-ceiling); the bookcase will be adjusted to size according to the distance detected.** We recommend that you check the room height in more than one point in order to find any excessive differences. With false ceilings you should check that in the event of inflection, the height difference does not exceed the 2 cm maximum adjustable range of the feet.



# Self standing bookcases maxi Dpt 33.3 - Dividing panels

## Melamine-faced dividing panels Ht 29.5

Load-bearing

Can be equipped with standard doors and drawers.

SHARE (A)		SHARE (B)	
Th 2.5		Th 2.5	
<b>Dpt</b>	<b>Code</b>	<b>Dpt</b>	<b>Code</b>
30.8	PL87.70D	33.3	PL87.71L

## Melamine-faced dividing panels Ht 29.5

Load-bearing

ELLE (B)		SEPARÉ (B)		COMMA (B)	
Dpt 30.8 Th 2.5		Dpt 30.8 Th 2.5		Dpt 30.8 Th 2.5	
<b>W</b>	<b>Code</b>	<b>W</b>	<b>Code</b>	<b>W</b>	<b>Code</b>
30	PL87.72S	32.5	PL87.77Z	30	PK83.64E
45	PL87.73Y	47.5	PL87.78F	45	PK83.65M
60	PL87.74E	62.5	PL87.79N	60	PK83.66T
75	PL87.75M	77.5	PL87.80K	75	PK83.67Z
90	PL87.76T	92.5	PL87.81R	90	PK83.68F

## Perspex dividing panels Ht 29.5

Load-bearing

Colours available:  
SV8X GF2B

PLEXY (A B)		FLAG (A B)	
Th 0.8		W 12.5	
<b>Dpt</b>	<b>Code</b>	<b>Dpt</b>	<b>Code</b>
28.5	PL87.82X	28.5	PL87.83D

## Metal dividing panels Ht 29.5

Colours available:  
B17A G28A GV7A GL7H

POKER (A B)		SUNDER (A B)	
Dpt 30.8 Th 2		Dpt 28.5 Th 2	
<b>W</b>	<b>Code</b>	<b>W</b>	<b>Code</b>
10	PL87.84L	29.5	PL87.87E
25	PL87.85S		
40	PL87.86Y		

This dividing system may be used only if together with melamine-faced dividing panel or the bookcase side panel.

## Movable shelves

use with dividing panels SHARE

	Melamine-coated Th 2,5			In transparent tempered glass Th 0,8		led spotlights Ø 6.5 We provide a power pack (with a surcharge) able to support from 1 to 6 spotlights. 12 volt 1.7 watt.
	Dpt 30.8 (A)	Dpt 33.3 (B)	Dpt 29.8 with led (A)	Dpt 28.5 (A B)	Dpt 28.5 with led (A)	
<b>W 27.5</b>	Code	PL86.00M	PL86.01T	-	-	Code
<b>W 42.5</b>	Code	PL86.02Z	PL86.03F	PL86.04N	PL86.05U	PL86.06A
<b>W 57.5</b>	Code	PL86.07G	PL86.08P	PL86.09V	PL86.10S	PL86.11Y
<b>W 87.5</b>	Code	PL86.12E	PL86.13M	PL86.14T	PL86.15Z	PL86.16F
						Code
						PL86.17N
						Code
						PL86.18U

Wireless switch  
For led lighting (usable for shelves and for spotlight).

## Dividing panel positioning instructions

The grid in each horizontal section is divided every 15 cm.  
Dividing panels must be mounted following the instruction below:  
**SIDE compartments L Max 73.8 - Min 28.8 cm.**  
**MIDDLE compartments L Max 75 - Min 30 cm.**  
The position of load-bearing dividing panels establishes the holes on the above and below shelves.

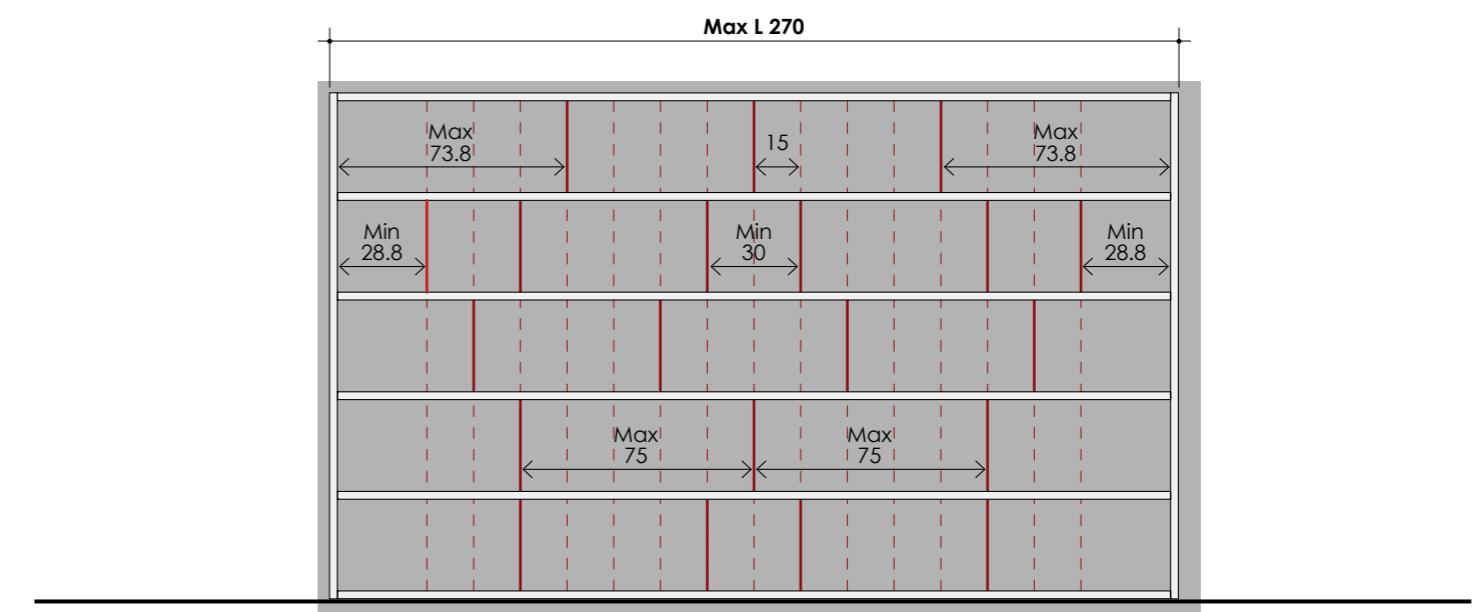

We provide a power pack (with a surcharge) able to support from 1 to 6 shelves W 45/60 or from 1 to 4 shelves W 90

- Components in **GROUP 2 colors**
- (A) For bookcases with back
- (B) For see-through/two-sided bookcases



# Self standing bookcases Dpt 33.3 - Semi-suspended

PODIO bench Dpt 49 - Ht 8 p. 583

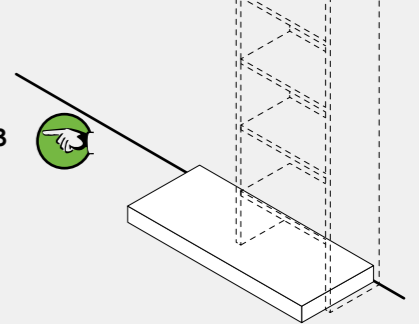

on self standing banches PODIO H 8

With back panel

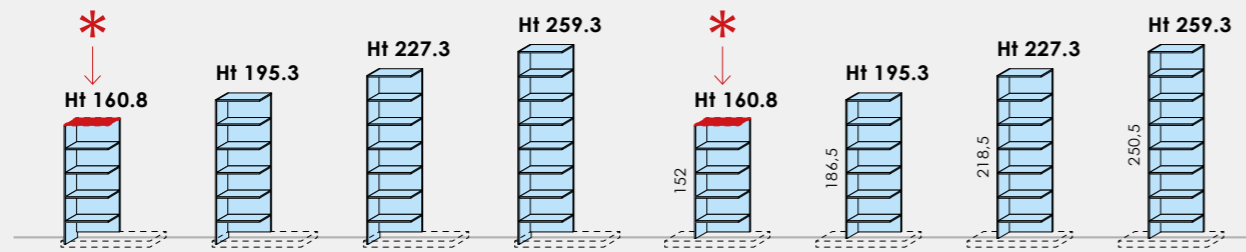

W 30	Code	PL88.75R	PL88.10A	PL88.11G	PL88.12P	PL88.76X	PL88.13V	PL88.14B	PL88.15H
W 45	Code	PL88.77D	PL88.16Q	PL88.17W	PL88.18C	PL88.78L	PL88.19K	PL88.20F	PL88.21N
W 60	Code	PL88.79S	PL88.22U	PL88.23A	PL88.24G	PL88.80P	PL88.25P	PL88.26V	PL88.27B
W 90	Code	PL88.81V	PL88.28H	PL88.29Q	PL88.30M	PL88.82B	PL88.31T	PL88.32Z	PL88.33F

See-through

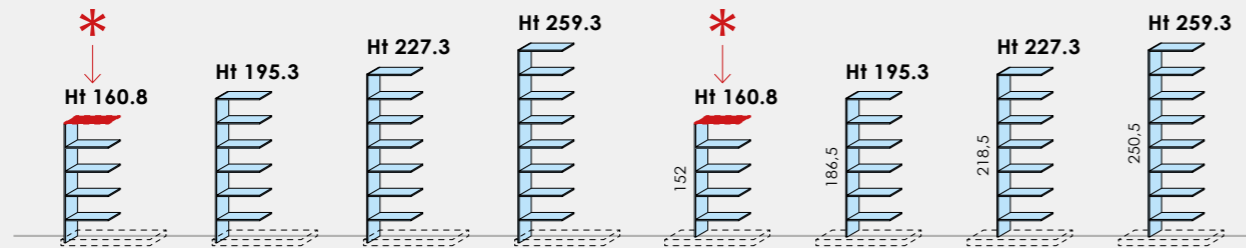

W 30	Code	PL88.83H	PL88.34N	PL88.35U	PL88.36A	PL88.84Q	PL88.37G	PL88.38P	PL88.39V
W 45	Code	PL88.85W	PL88.40S	PL88.41Y	PL88.42E	PL88.86C	PL88.43M	PL88.44T	PL88.45Z
W 60	Code	PL88.87K	PL88.46F	PL88.47N	PL88.48U	PL88.88R	PL88.49A	PL88.50X	PL88.51D
W 90	Code	PL88.89X	PL88.52L	PL88.53S	PL88.54Y	PL88.90U	PL88.55E	PL88.56M	PL88.57T

Movable shelves

		Melamine-coated Th 2,5			In transparent tempered glass Th 0,8	
		Dpt 30.8	Dpt 33.3	Dpt 29.8 with led	Dpt 28.5	Dpt 28.5 with led
W 27.5	Code	PL86.00M	PL86.01T	-	-	-
W 42.5	Code	PL86.02Z	PL86.03F	PL86.04N	PL86.05U	PL86.06A
W 57.5	Code	PL86.07G	PL86.08P	PL86.09V	PL86.10S	PL86.11Y
W 87.5	Code	PL86.12E	PL86.13M	PL86.14T	PL86.15Z	PL86.16F

led spotlights Ø 6.5  
We provide a power pack (with a surcharge) able to support from 1 to 6 spotlights. 12 volt 1.7 watt.

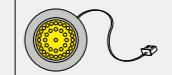

Code	PL86.17N
------	----------

Wireless switch  
For led lighting (usable for shelves and for spotlight).

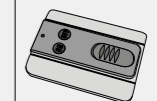

Code	PL86.18U
------	----------

Semi-suspended Side panels Dpt 33.3 - Th 2.5 for PODIO

Code	PL88.95B	PL88.72W	PL88.73C	PL88.74K				
------	----------	----------	----------	----------	--	--	--	--

Backs Th 1.8

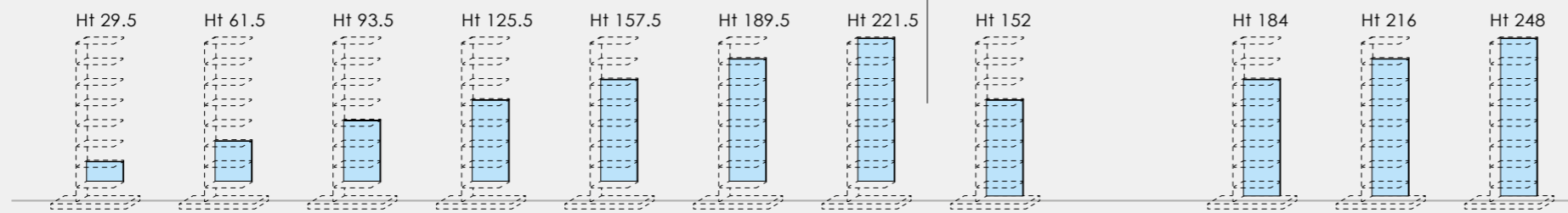

W 27.5	Code	PL85.64R	PL85.65X	PL85.66D	PL85.67L	PL85.68S	PL85.69Y	PL85.70V	PL88.91A	PL88.60C	PL88.64D	PL88.65L
W 42.5	Code	PL85.72H	PL85.73Q	PL85.74W	PL85.75C	PL85.76K	PL85.77R	PL85.78X	PL88.92G	PL88.61K	PL88.66S	PL88.67Y
W 57.5	Code	PL85.80A	PL85.81G	PL85.82P	PL85.83V	PL85.84B	PL85.85H	PL85.86Q	PL88.93P	PL88.62R	PL88.68E	PL88.69M
W 87.5	Code	PL85.88C	PL85.89K	PL85.90F	PL85.91N	PL85.92U	PL85.93A	PL85.94G	PL88.94V	PL88.63X	PL88.70H	PL88.71Q

SEMI-SUSPENDED bookcases must always have a floor standing side panel. Drawers and doors can not be mounted on this compartment (✘).

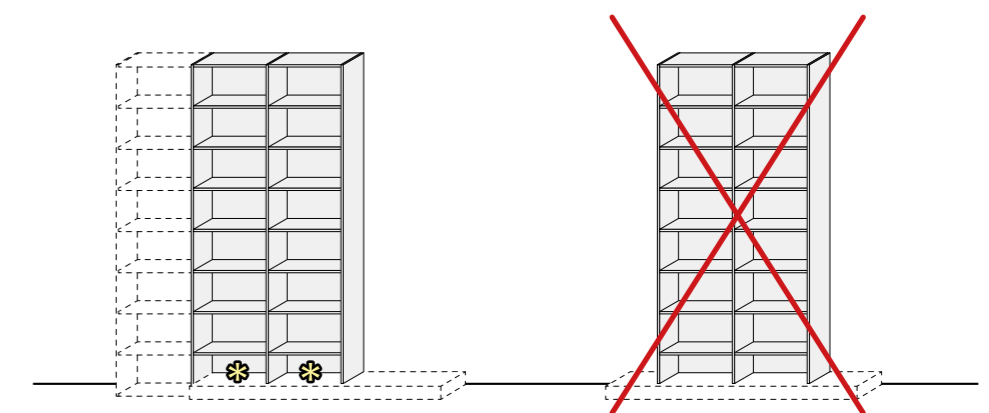

- Components in GROUP 2 colors
- A For bookcases with back
- B For see-through bookcases
- \* To be completed with Top Th 2.5

We provide a power pack (with a surcharge) able to support from 1 to 6 shelves W 45/60 or from 1 to 4 shelves W 90

p. 732 Doors INFINITY  
p. 735 Drawers INFINITY  
p. 736 Sliding doors INFINITY

p. 745 Top Dpt 33.3 - Th 2.5 (\*)

# Self standing bookcases Dpt 33.3 - Semi-suspended

Floor/support modular units Dpt 56.3 - Ht 16 p. 616  
 Floor/support modular units Dpt 45 - Ht 16 p. 628

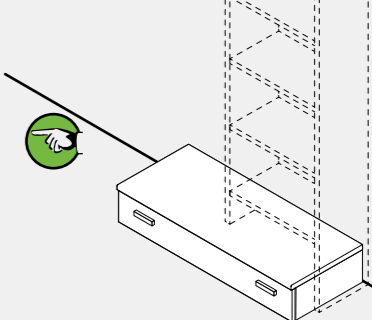

on floor standing Modular components Ht 16 + top Th 2.5

With back panel

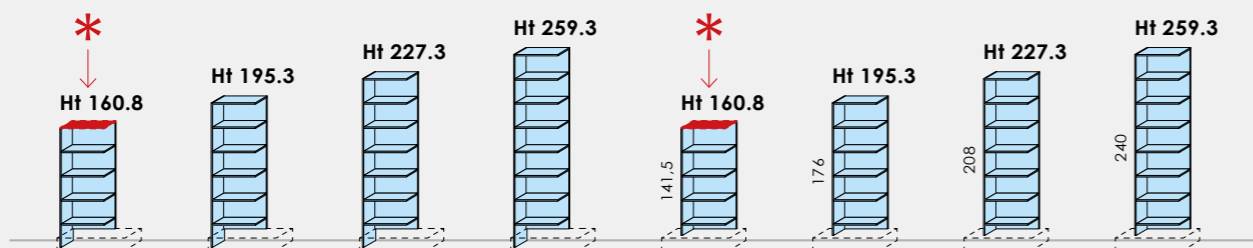

W 30	Code	PL89.65Q	PL89.00Z	PL89.01F	PL89.02N	PL89.66W	PL89.03U	PL89.04A	PL89.05G
W 45	Code	PL89.67C	PL89.06P	PL89.07V	PL89.08B	PL89.68K	PL89.09H	PL89.10E	PL89.11M
W 60	Code	PL89.69R	PL89.12T	PL89.13Z	PL89.14F	PL89.70N	PL89.15N	PL89.16U	PL89.17A
W 90	Code	PL89.71U	PL89.18G	PL89.19P	PL89.20L	PL89.72A	PL89.21S	PL89.22Y	PL89.23E

See-through

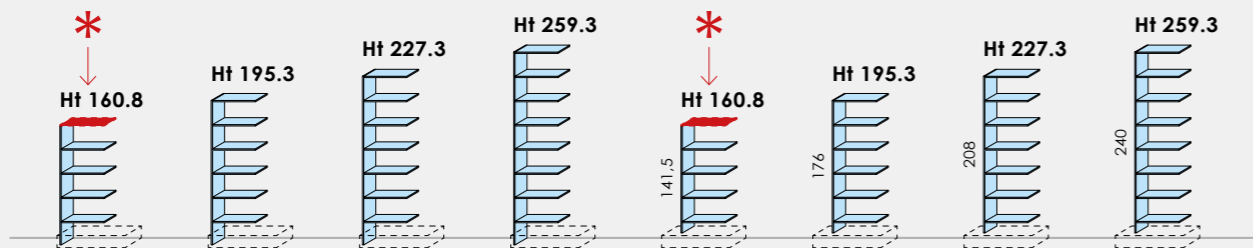

W 30	Code	PL89.73G	PL89.24M	PL89.25T	PL89.26Z	PL89.74P	PL89.27F	PL89.28N	PL89.29U
W 45	Code	PL89.75V	PL89.30R	PL89.31X	PL89.32D	PL89.76B	PL89.33L	PL89.34S	PL89.35Y
W 60	Code	PL89.77H	PL89.36F	PL89.37M	PL89.38T	PL89.78Q	PL89.39Z	PL89.40W	PL89.41C
W 90	Code	PL89.79W	PL89.42K	PL89.43R	PL89.44X	PL89.80T	PL89.45D	PL89.46L	PL89.47S

Movable shelves

W 27.5	Code	Melamine-coated Th 2.5		In transparent tempered glass Th 0,8		
		Dpt 30.8	Dpt 33.3	Dpt 29.8 with led	Dpt 28.5	Dpt 28.5 with led
W 42.5	Code	PL86.00M	PL86.01T	-	-	-
W 57.5	Code	PL86.02Z	PL86.03F	PL86.04N	PL86.05U	PL86.06A
W 87.5	Code	PL86.07G	PL86.08P	PL86.09V	PL86.10S	PL86.11Y
	Code	PL86.12E	PL86.13M	PL86.14T	PL86.15Z	PL86.16F

led spotlights Ø 6.5  
 We provide a power pack (with a surcharge) able to support from 1 to 6 spotlights. 12 volt 1.7 watt.

Code	PL86.17N
------	----------

Wireless switch  
 For led lighting (usable for shelves and for spotlight).

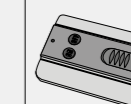

Code	PL86.18U
------	----------

Semi-suspended Side panels  
 Dpt 33.3 - Th 2.5  
 for Modular components H 16

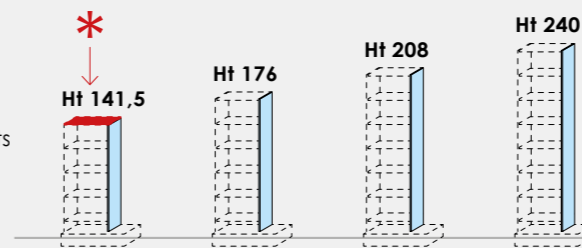

Code	PL89.85A	PL89.62V	PL89.63B	PL89.64H				

Backs Th 1.8

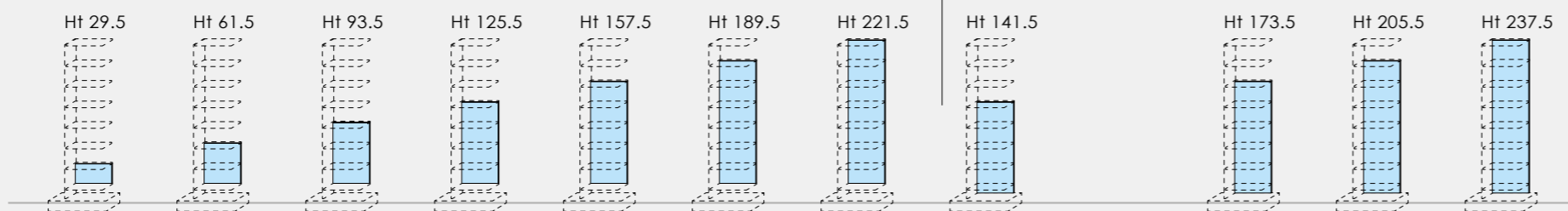

W 27.5	Code	PL85.64R	PL85.65X	PL85.66D	PL85.67L	PL85.68S	PL85.69Y	PL85.70V	PL89.81Z	PL89.50B	PL89.54C	PL89.55K
W 42.5	Code	PL85.72H	PL85.73Q	PL85.74W	PL85.75C	PL85.76K	PL85.77R	PL85.78X	PL89.82F	PL89.51H	PL89.56R	PL89.57X
W 57.5	Code	PL85.80A	PL85.81G	PL85.82P	PL85.83V	PL85.84B	PL85.85H	PL85.86Q	PL89.83N	PL89.52Q	PL89.58D	PL89.59L
W 87.5	Code	PL85.88C	PL85.89K	PL85.90F	PL85.91N	PL85.92U	PL85.93A	PL85.94G	PL89.84U	PL89.53W	PL89.60G	PL89.61P

To be placed on support Modular component Ht 16 + top Th 2.5

SEMI-SUSPENDED bookcases must always have a floor standing side panel. Drawers and doors can not be mounted on this compartment (✘).

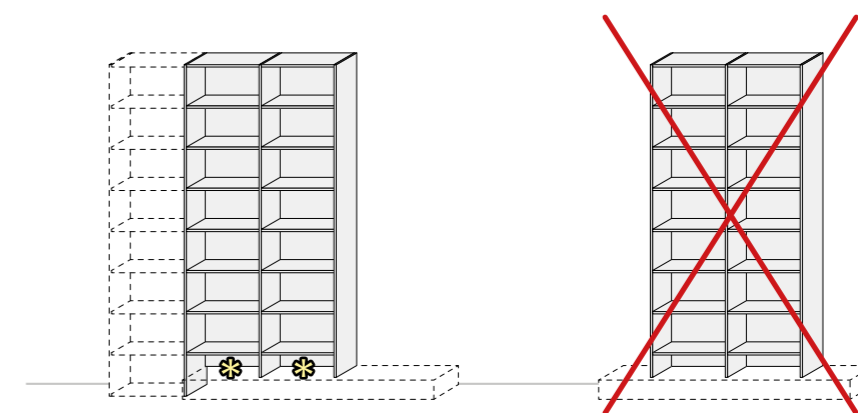

- Components in GROUP 2 colors
- A For bookcases with back
- B For see-through bookcases
- \* To be completed with Top Th 2.5

We provide a power pack (with a surcharge) able to support from 1 to 6 shelves W 45/60 or from 1 to 4 shelves W 90

p. 732 Doors INFINITY  
 p. 735 Drawers INFINITY  
 p. 736 Sliding doors INFINITY

p. 745 Top Dpt 33.3 - Th 2.5 (\*)

# Self standing bookcases Dpt 33.3 - Semi-suspended

Floor/support modular units Dpt 56.3 - Ht 32 p. 616  
 Floor/support modular units Dpt 45 - Ht 32 p. 628

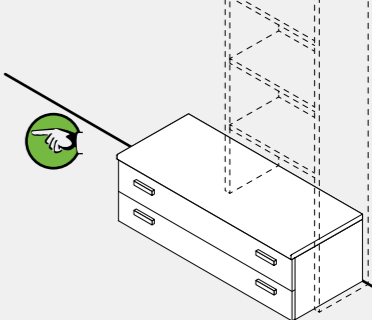

on floor standing Modular components Ht 32 + top Th 2.5

With back panel

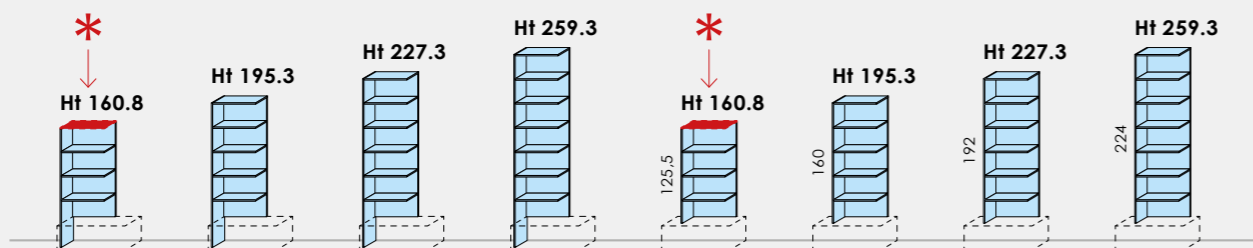

W 30	Code	PL91.58X	PL90.00P	PL90.01V	PL90.02B	PL91.59D	PL90.03H	PL90.04Q	PL90.05W
W 45	Code	PL91.60A	PL90.06C	PL90.07K	PL90.08R	PL91.61G	PL90.09X	PL90.10U	PL90.11A
W 60	Code	PL91.62P	PL90.12G	PL90.13P	PL90.14V	PL91.63V	PL90.15B	PL90.16H	PL90.17Q
W 90	Code	PL91.64B	PL90.18W	PL90.19C	PL90.20Z	PL91.65H	PL90.21F	PL90.22N	PL90.23U

See-through

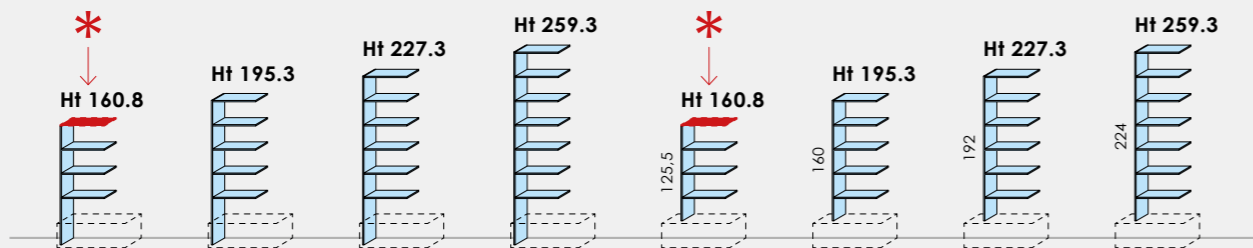

W 30	Code	PL91.66Q	PL90.24A	PL90.25G	PL90.26P	PL91.67W	PL90.27V	PL90.28B	PL90.29H
W 45	Code	PL91.68C	PL90.30E	PL90.31M	PL90.32T	PL91.69K	PL90.33Z	PL90.34F	PL90.35N
W 60	Code	PL91.70F	PL90.36U	PL90.37A	PL90.38G	PL91.71N	PL90.39P	PL90.40L	PL90.41S
W 90	Code	PL91.72U	PL90.42Y	PL90.43E	PL90.44M	PL91.73A	PL90.45T	PL90.46Z	PL90.47F

Backs Th 1.8

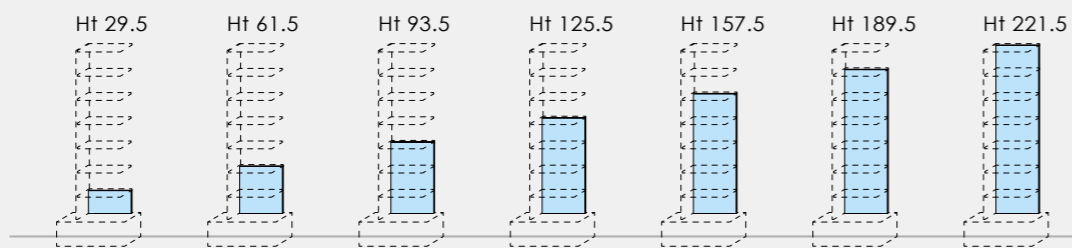

W 27.5	Code	PL85.64R	PL85.65X	PL85.66D	PL85.67L	PL85.68S	PL85.69Y	PL85.70V
W 42.5	Code	PL85.72H	PL85.73Q	PL85.74W	PL85.75C	PL85.76K	PL85.77R	PL85.78X
W 57.5	Code	PL85.80A	PL85.81G	PL85.82P	PL85.83V	PL85.84B	PL85.85H	PL85.86Q
W 87.5	Code	PL85.88C	PL85.89K	PL85.90F	PL85.91N	PL85.92U	PL85.93A	PL85.94G

- Components in **GROUP 2** colors
- A For bookcases with back
- B For see-through bookcases
- ✱ To be completed with Top Th 2.5

Movable shelves

W 27.5	Code	Melamine-coated Th 2.5		In transparent tempered glass Th 0,8		
		Dpt 30.8	Dpt 33.3	Dpt 29.8 with led	Dpt 28.5	Dpt 28.5 with led
W 42.5	Code	PL86.00M	PL86.01T	-	-	-
W 57.5	Code	PL86.02Z	PL86.03F	PL86.04N	PL86.05U	PL86.06A
W 87.5	Code	PL86.07G	PL86.08P	PL86.09V	PL86.10S	PL86.11Y
W 87.5	Code	PL86.12E	PL86.13M	PL86.14T	PL86.15Z	PL86.16F

**led spotlights Ø 6.5**  
 We provide a power pack (with a surcharge) able to support from 1 to 6 spotlights. 12 volt 1.7 watt.



Code	PL86.17N
------	----------

**Wireless switch**  
 For led lighting (usable for shelves and for spotlight).

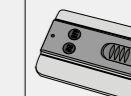

Code	PL86.18U
------	----------

Semi-suspended Side panels Dpt 33.3 - Th 2.5 for Modular components H 32

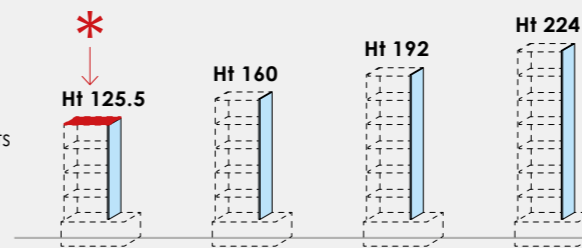

Code	PL91.74G	PL90.48N	PL90.49U	PL90.50R

**SEMI-SUSPENDED** bookcases must always have a floor standing side panel. Drawers and doors can not be mounted on this compartment (✱).

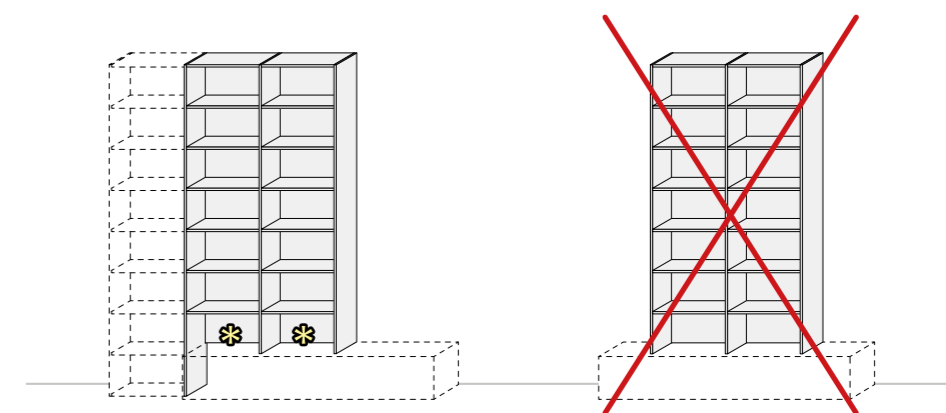

■ We provide a power pack (with a surcharge) able to support from 1 to 6 shelves W 45/60 or from 1 to 4 shelves W 90

■ p. 732 Doors INFINITY  
 p. 735 Drawers INFINITY  
 p. 736 Sliding doors INFINITY

p. 745 Top Dpt 33.3 - Th 2.5 (✱)

# Self standing bookcases Dpt 33.3 - Semi-suspended

Floor/support modular units Dpt 56.3 - Ht 64 p. 617  
 Floor/support modular units Dpt 45 - Ht 64 p. 629

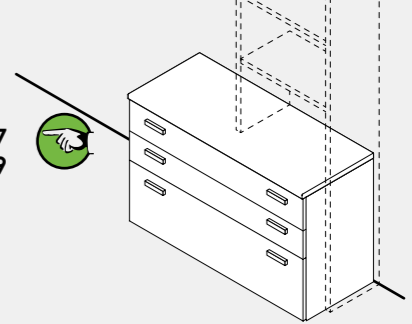

on floor standing Modular components Ht 64 + top Th 2.5

With back panel

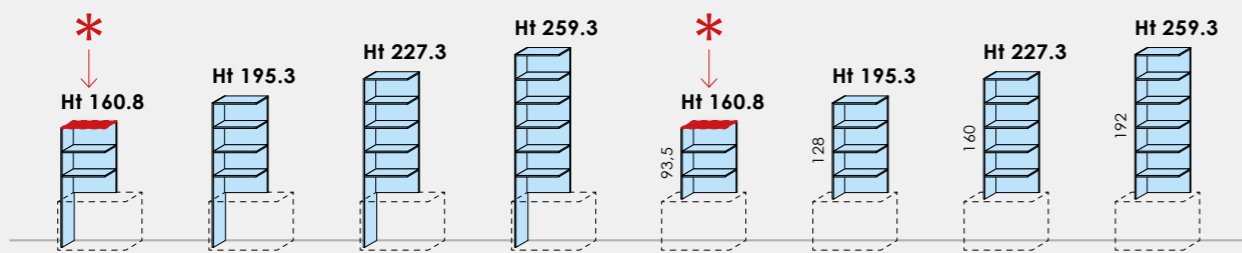

W 30	Code	PL91.75P	PL90.51X	PL90.52D	PL90.53L	PL91.76V	PL90.54S	PL90.55Y	PL90.56E
W 45	Code	PL91.77B	PL90.57M	PL90.58T	PL90.59Z	PL91.78H	PL90.60W	PL90.61C	PL90.62K
W 60	Code	PL91.79Q	PL90.63R	PL90.64X	PL90.65D	PL91.80M	PL90.66L	PL90.67S	PL90.68Y
W 90	Code	PL91.81T	PL90.69E	PL90.70B	PL90.71H	PL91.82Z	PL90.72Q	PL90.73W	PL90.74C

See-through

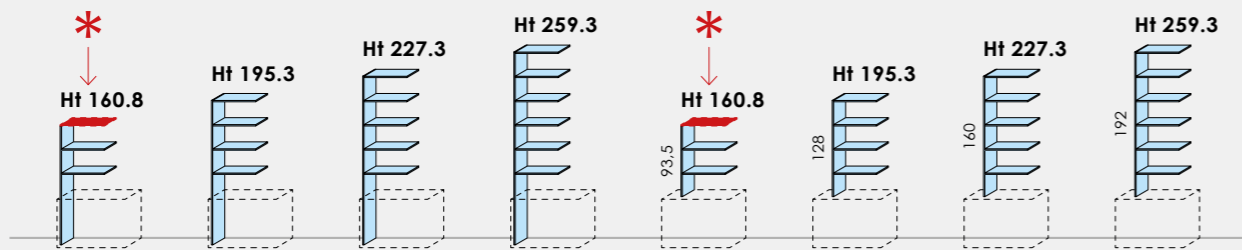

W 30	Code	PL91.83F	PL90.75K	PL90.76R	PL90.77X	PL91.84N	PL90.78D	PL90.79L	PL90.80G
W 45	Code	PL91.85U	PL90.81P	PL90.82V	PL90.83B	PL91.86A	PL90.84H	PL90.85Q	PL90.86W
W 60	Code	PL91.87G	PL90.87C	PL90.88K	PL90.89R	PL91.88P	PL90.90N	PL90.91U	PL90.92A
W 90	Code	PL91.89V	PL90.93G	PL90.94P	PL90.95V	PL91.90S	PL90.96B	PL90.97H	PL90.98Q

Backs Th 1.8

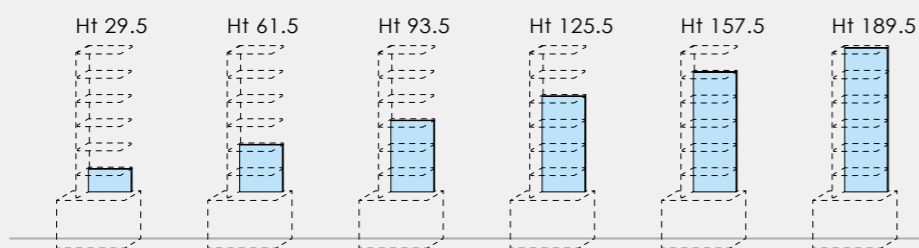

W 27.5	Code	PL85.64R	PL85.65X	PL85.66D	PL85.67L	PL85.68S	PL85.69Y				
W 42.5	Code	PL85.72H	PL85.73Q	PL85.74W	PL85.75C	PL85.76K	PL85.77R				
W 57.5	Code	PL85.80A	PL85.81G	PL85.82P	PL85.83V	PL85.84B	PL85.85H				
W 87.5	Code	PL85.88C	PL85.89K	PL85.90F	PL85.91N	PL85.92U	PL85.93A				

- Components in **GROUP 2** colors
- A For bookcases with back
- B For see-through bookcases
- ✱ To be completed with Top Th 2.5

Movable shelves

W 27.5	Code	Melamine-coated Th 2.5		In transparent tempered glass Th 0,8		
		Dpt 30.8	Dpt 33.3	Dpt 29.8 with led	Dpt 28.5	Dpt 28.5 with led
W 42.5	Code	PL86.00M	PL86.01T	-	-	-
W 57.5	Code	PL86.02Z	PL86.03F	PL86.04N	PL86.05U	PL86.06A
W 87.5	Code	PL86.12E	PL86.13M	PL86.14T	PL86.15Z	PL86.16F

**led spotlights Ø 6.5**  
 We provide a power pack (with a surcharge) able to support from 1 to 6 spotlights. 12 volt 1.7 watt.



Code	PL86.17N
------	----------

**Wireless switch**  
 For led lighting (usable for shelves and for spotlight).

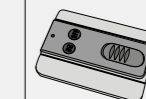

Code	PL86.18U
------	----------

Semi-suspended Side panels Dpt 33.3 - Th 2.5 for Modular components Ht 64

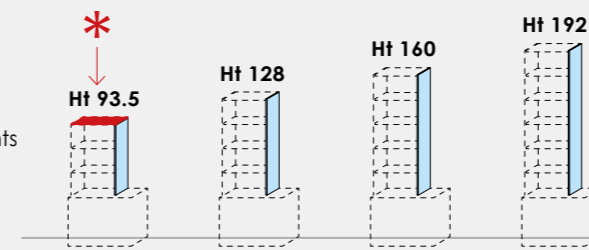

Code	PL91.91Y	PL90.99W	PL90.48N	PL90.49U				

**SEMI-SUSPENDED bookcases must always have a floor standing side panel.**  
 Drawers and doors can not be mounted on this compartment (✱).

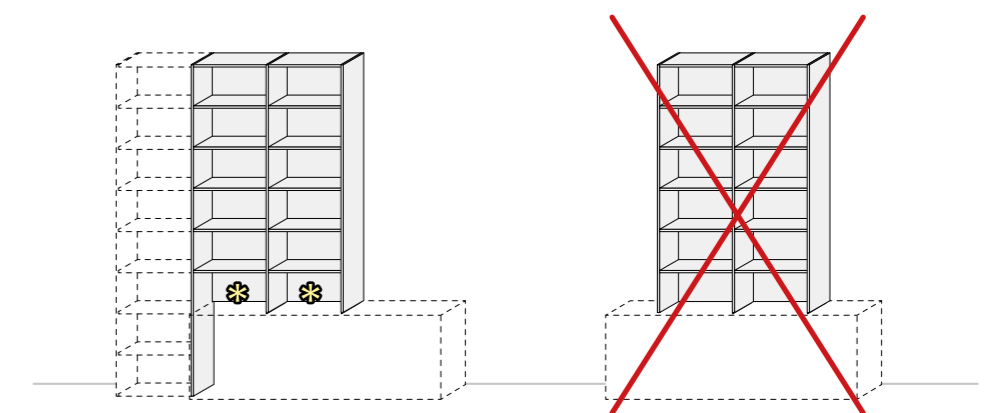

■ We provide a power pack (with a surcharge) able to support from 1 to 6 shelves W 45/60 or from 1 to 4 shelves W 90

■ p. 732 Doors INFINITY  
 p. 735 Drawers INFINITY  
 p. 736 Sliding doors INFINITY

p. 745 Top Dpt 33.3 - Th 2.5 (✱)



## Self standing corner bookcases Dpt 33.3 - Full corner

With back panel

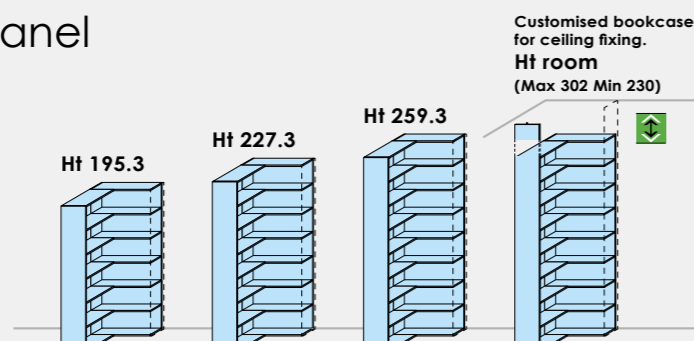

Code	PL91.10Y	PL91.11E	PL91.12M	PL91.26T	PL91.21L
------	----------	----------	----------	----------	----------

Movable shelves

Melamine-coated  
Dpt 30.8  
Th 2.5

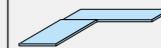

See-through

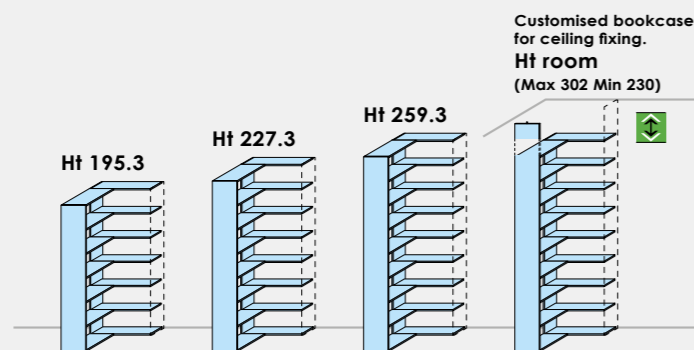

Code	PL91.15F	PL91.16N	PL91.17U	PL91.27Z	PL91.22S
------	----------	----------	----------	----------	----------

Melamine-coated  
Dpt 33.3  
Th 2.5



Side panels on floor  
Dpt 33.3 - Th 2.5

(H 0.8 foot not included)

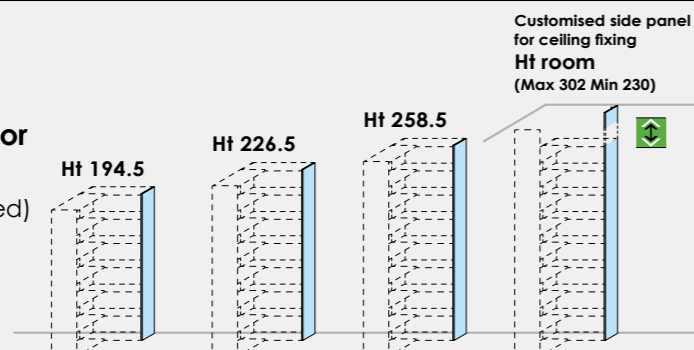

Code	PL86.29F	PL86.30C	PL86.31K	PL85.96V
------	----------	----------	----------	----------

Technical information

- Available in open version or with pair of doors.
- Handle is always provided on the Right door.
- Size proportion changes are not available.

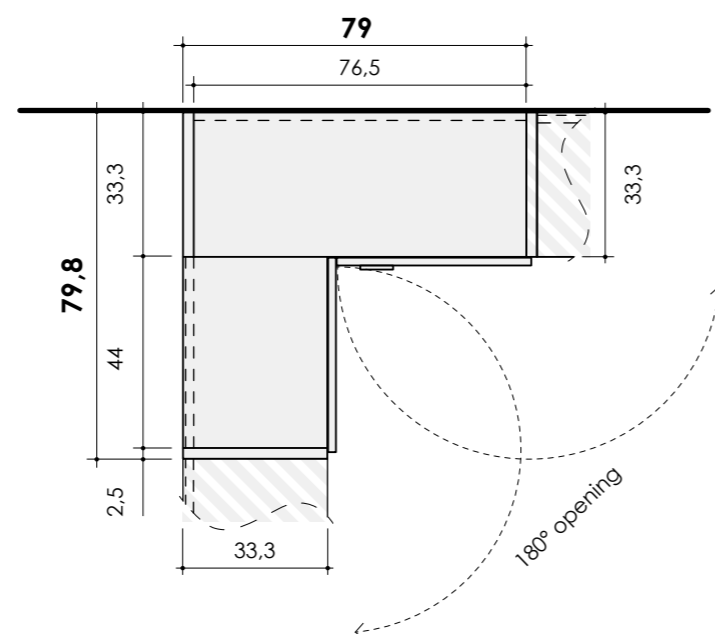

Components in GROUP 2 colors

The side panel is equipped with adjustable feet (top and bottom) for fixing between floor and ceiling which allow a maximum adjustment of 20 mm. **When ordering it is necessary to indicate the room height (floor-ceiling); the bookcase will be adjusted to size according to the distance detected.** We recommend that you check the room height in more than one point in order to find any excessive differences. With false ceilings you should check that in the event of inflection, the height difference does not exceed the 2 cm maximum adjustable range of the feet.

## Self standing end-bookcases Dpt 33.3

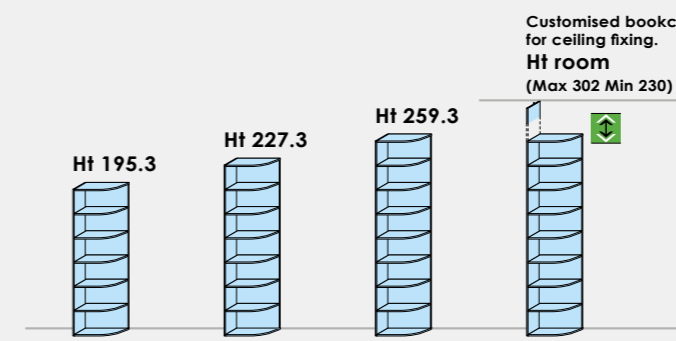

Code	PL91.18A	PL91.19G	PL91.20D	PL91.28F	PL91.23Y
------	----------	----------	----------	----------	----------

Movable shelves

Melamine-coated  
Dpt 30.8  
Th 2.5



Technical information

- Available only in open version.

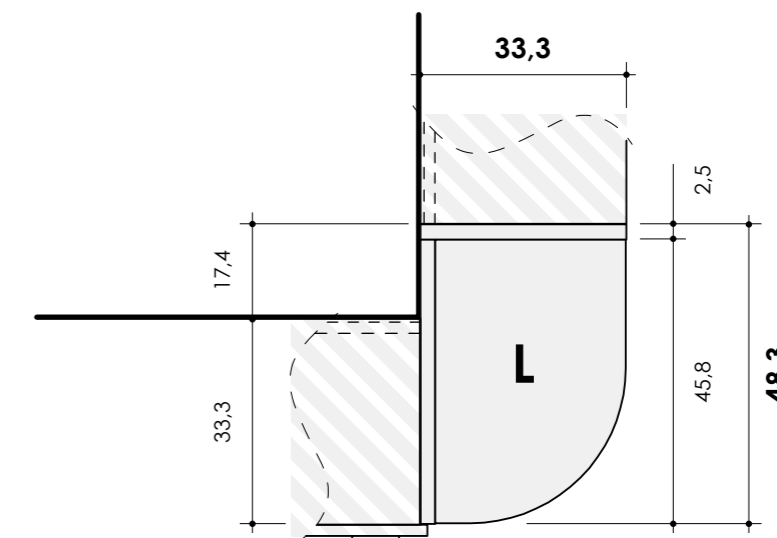
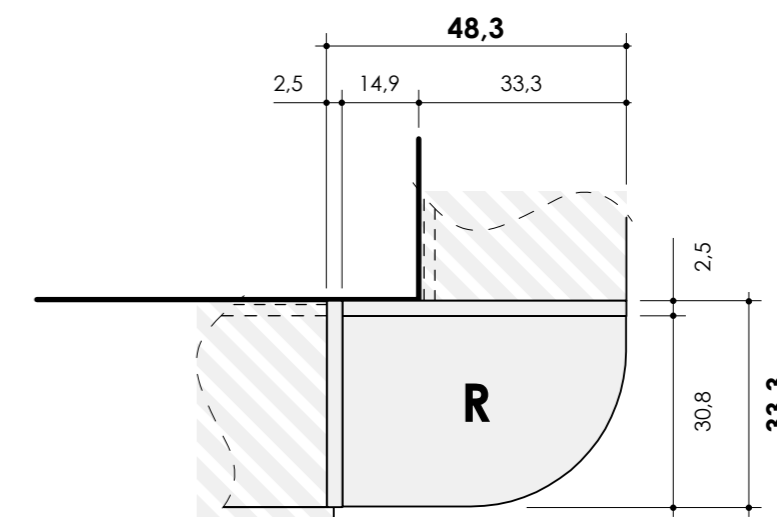
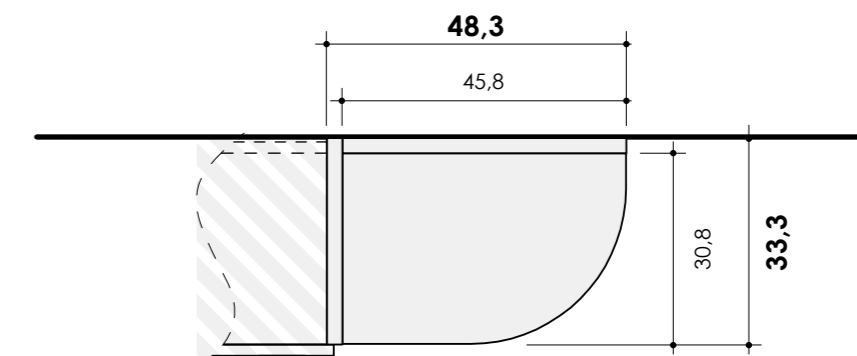

# Self standing bookcases Dpt 33.3 - For passage

With back panel

**W 90**

Specify hinge  
R or L

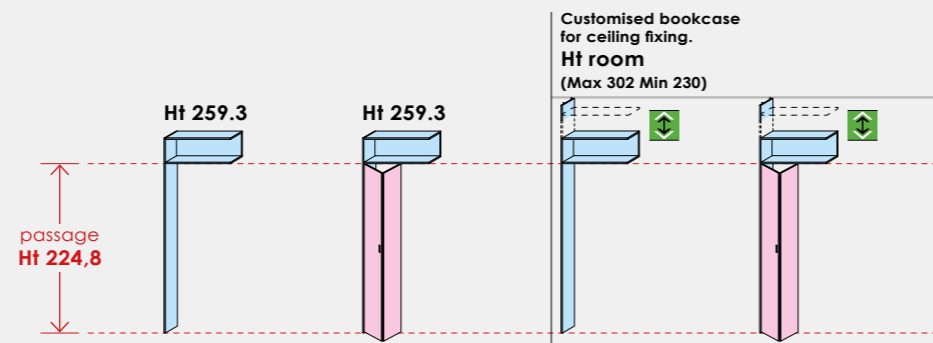

Code	PK83.60D	PK83.92H	PK83.61L	PK83.93Q
ONE	matte			
	glossy			

Two-sided see-through units

**W 90**

Specify hinge  
R or L

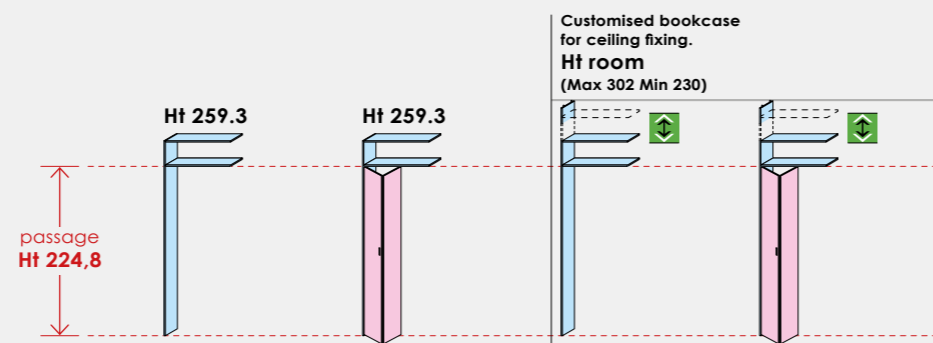

Code	PK83.62S	PK83.94W	PK83.63Y	PK83.95C
ONE	matte			
	glossy			

**Movable shelves**

Melamine-coated  
Th 2,5

In transparent tempered glass  
Th 0,8

Dpt 30.8



Dpt 33.3



Dpt 29.8 with led



Dpt 28.5

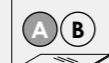

Dpt 28.5 with led



**W 87.5**

Code	PL86.12E	PL86.13M	PL86.14T	PL86.15Z	PL86.16F

**led spotlights Ø 6.5**  
We provide a power pack (with a surcharge) able to support from 1 to 6 spotlights, 12 volt 1.7 watt.



**Wireless switch**  
For led lighting (usable for shelves and for spotlight).

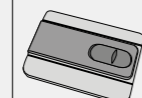

Code	PL86.17N	PL86.18U

## Technical information

- The over-door bookshelves (without bottom panel) must be between two wardrobes with bottom panel, one on the right, and one on the left.
- In the presence of folding doors specify whether the hinge is R or L. There is only one handle positioned on the door hinged to the side.
- Track for folding door in Aluminium colour.

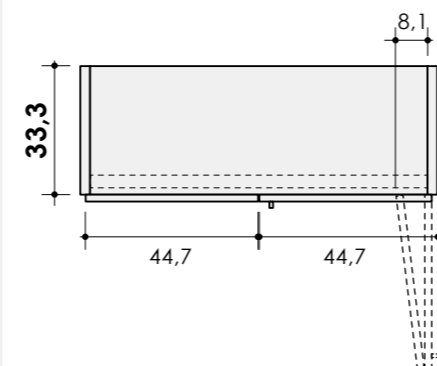

- Components in **GROUP 2**
- Components in **Types and colors FRONT**
- Ⓐ For bookcases with back
- Ⓑ For see-through/two-sided bookcases

⬆️ The side panel is equipped with adjustable feet (top and bottom) for fixing between floor and ceiling which allow a maximum adjustment of 20 mm. **When ordering it is necessary to indicate the room height (floor-ceiling); the bookcase will be adjusted to size according to the distance detected.** We recommend that you check the room height in more than one point in order to find any excessive differences. With false ceilings you should check that in the event of inflection, the height difference does not exceed the 2 cm maximum adjustable range of the feet.

⦿ We provide a power pack (with a surcharge) able to support from 1 to 6 shelves W 45/60 or from 1 to 4 shelves W 90



# Floor boiserie

## Ht 195.3

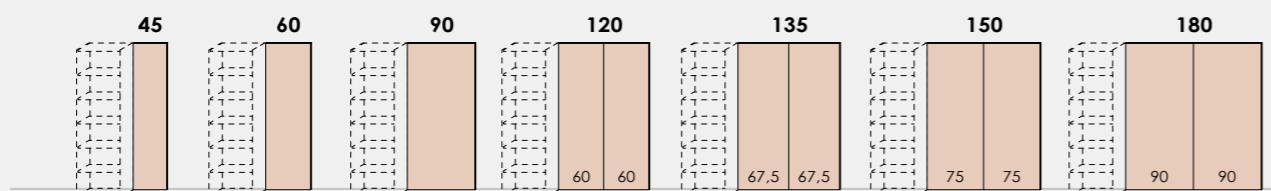

Code	PL91.30K	PL91.31R	PL91.32X	PL91.33D	PL91.34L	PL91.35S	PL91.36Y
------	----------	----------	----------	----------	----------	----------	----------

## Ht 227.3

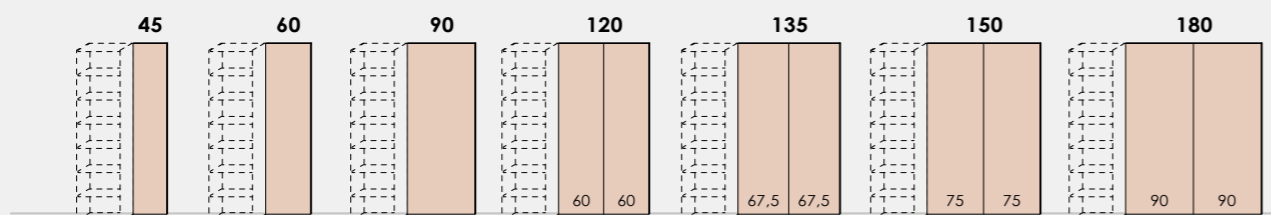

Code	PL91.37E	PL91.38M	PL91.39T	PL91.40Q	PL91.41W	PL91.42C	PL91.43K
------	----------	----------	----------	----------	----------	----------	----------

## Ht 259.3

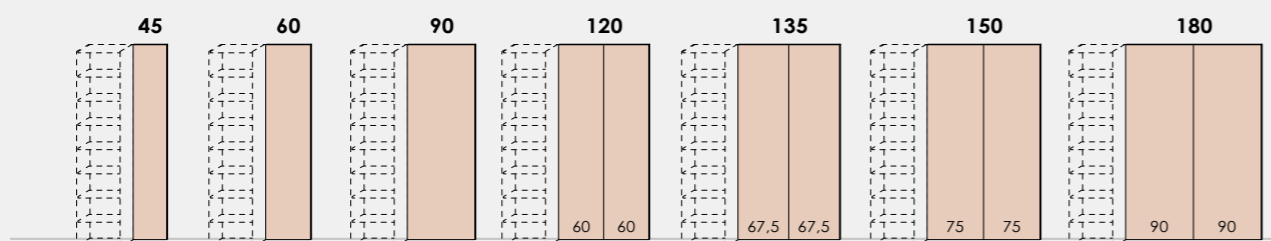

Code	PL91.44R	PL91.45X	PL91.46D	PL91.47L	PL91.48S	PL91.49Y	PL91.50V
------	----------	----------	----------	----------	----------	----------	----------

### Customized panel cuts

The upper measure panel is used by applying the surcharge.

Example:  
If you want a panel L 80 x H 180, use the panel Code **PL91.32X** and make 2 cuts; therefore the cost of the panel will be: 195,00 (35,00 x 2 + 125,00).

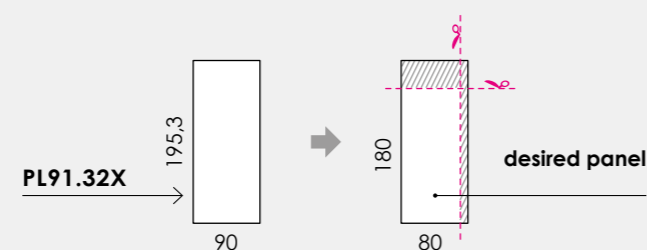

- Components in **GROUP 2 colors**
- Components in **GROUP 3 colors**

### Shelves Dpt 26 Th 2.5

For Boiserie  
With concealed fixing

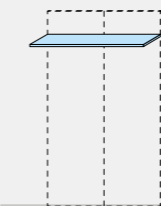

**led spotlights Ø 6.5**  
We provide a power pack (with a surcharge) able to support from 1 to 6 spotlights. 12 volt 1.7 watt.

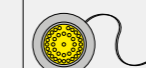

### Shelf fixing on Boiserie

**Maximum recommended load (net of shelves): 1 kg every 5 linear cm.**

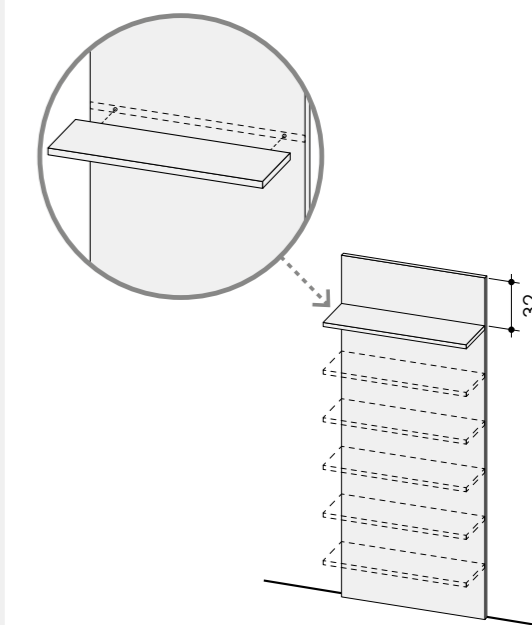

<b>W 45</b>	Code	PL91.51B	Code	PL86.17N
				23,00
<b>W 60</b>	Code	PL91.52H		
<b>W 90</b>	Code	PL91.53Q		
<b>W 120</b>	Code	PL91.54W		
<b>W 135</b>	Code	PL91.55C	Code	PL86.18U
<b>W 150</b>	Code	PL91.56K		
<b>W 180</b>	Code	PL91.57R		

**Wireless switch**  
For led lighting (usable for shelves and for spotlight).

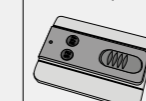

### Technical information

Supplied with wall fixing hardware and pre-drilling for shelves.

#### Wall fixing of the panel:

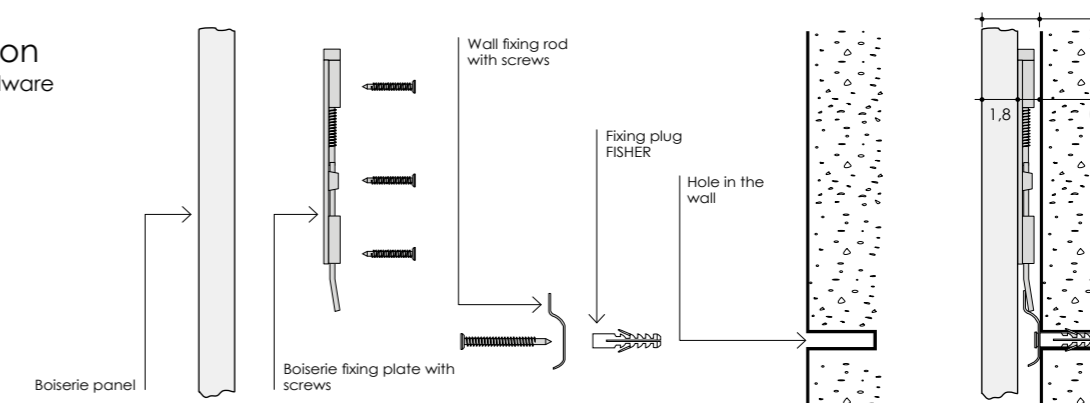

# Semi-suspended boiserie

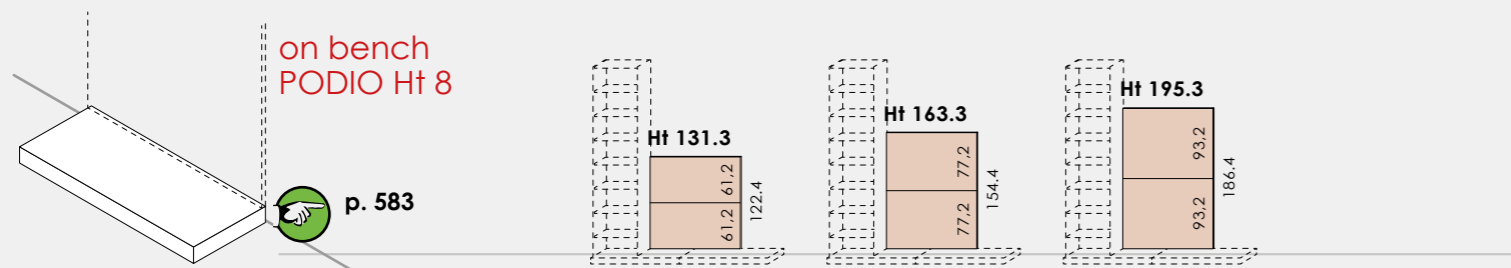

W 90	Code	PL92.00X	PL92.01D	PL92.02L
W 120	Code	PL92.03S	PL92.04Y	PL92.05E
W 135	Code	PL92.06M	PL92.07T	PL92.08Z
W 150	Code	PL92.09F	PL92.10C	PL92.11K
W 160	Code	PL92.12R	PL92.13X	PL92.14D

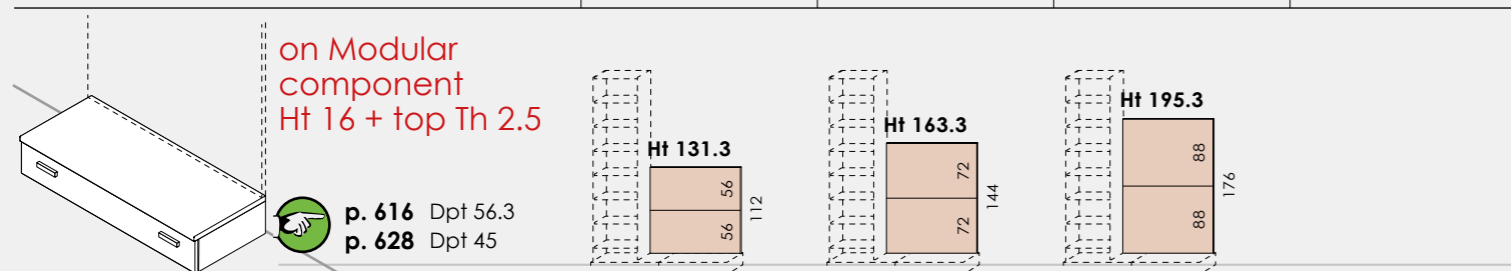

W 90	Code	PL92.15L	PL92.16S	PL92.17Y
W 120	Code	PL92.18E	PL92.19M	PL92.20H
W 135	Code	PL92.21Q	PL92.22W	PL92.23C
W 150	Code	PL92.24K	PL92.25R	PL92.26X
W 160	Code	PL92.27D	PL92.28L	PL92.29S

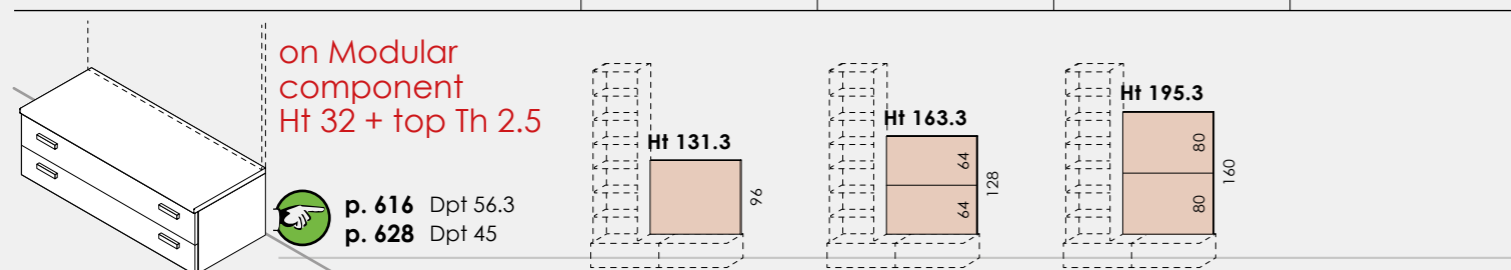

W 90	Code	PL92.30P	PL92.31V	PL92.32B
W 120	Code	PL92.33H	PL92.34Q	PL92.35W
W 135	Code	PL92.36C	PL92.37K	PL92.38R
W 150	Code	PL92.39X	PL92.40U	PL92.41A
W 160	Code	PL92.42G	PL92.43P	PL92.44V

Components in GROUP 2 colors  
Components in GROUP 3 colors

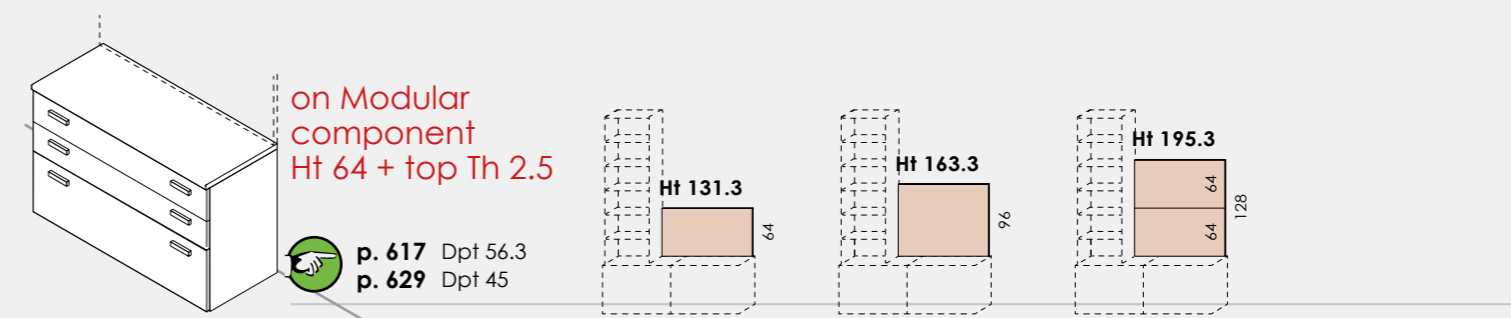

W 90	Code	PL92.45B	PL92.46H	PL92.47Q
W 120	Code	PL92.48W	PL92.49C	PL92.50Z
W 135	Code	PL92.51F	PL92.52N	PL92.53U
W 150	Code	PL92.54A	PL92.55G	PL92.56P
W 160	Code	PL92.57V	PL92.58B	PL92.59H

## Shelves Dpt 26 Th 2.5

For Boiserie  
With concealed fixing

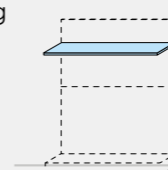

## led spotlights Ø 6.5

We provide a power pack (with a surcharge) able to support from 1 to 6 spotlights. 12 volt 1.7 watt.



W 60	Code	PL91.52H	Code	PL86.17N
W 90	Code	PL91.53Q		
W 105	Code	PL91.92E		
W 120	Code	PL91.54W		
W 135	Code	PL91.55C	Code	PL86.18U
W 150	Code	PL91.56K		
W 180	Code	PL91.57R		

## Wireless switch

For led lighting (usable for shelves and for spotlight).



## Shelf fixing on Boiserie

Maximum recommended load (net of shelves):  
1 kg every 5 linear cm.

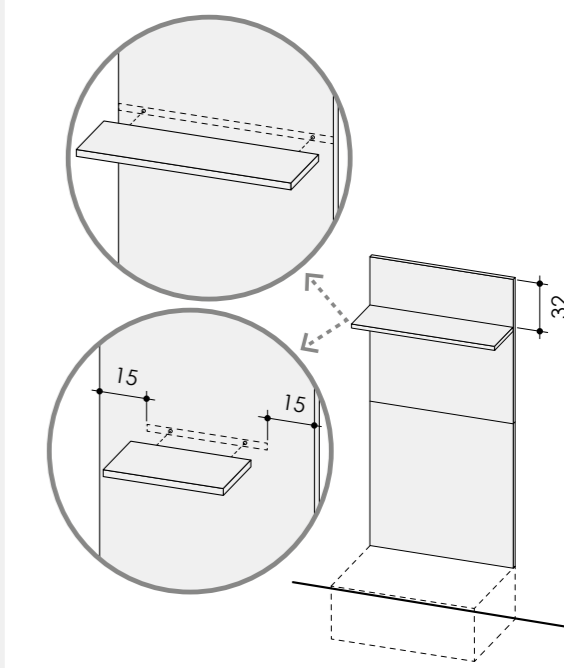

## Technical information

- Supplied with wall fixing hardware and pre-drilling for shelves.

### Wall fixing of the panel:

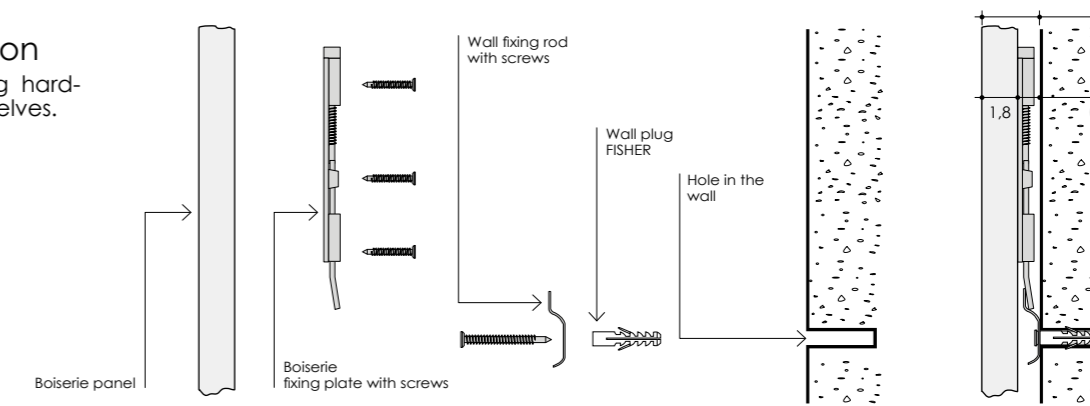

# Self standing bookcases Dpt 33.3 - With desk

With back panel

See-through

Side panels on floor  
Dpt 33.3 - Th 2.5  
(Ht 0.8 foot not included)

Ht 195.3

\* Specify hinge R or L

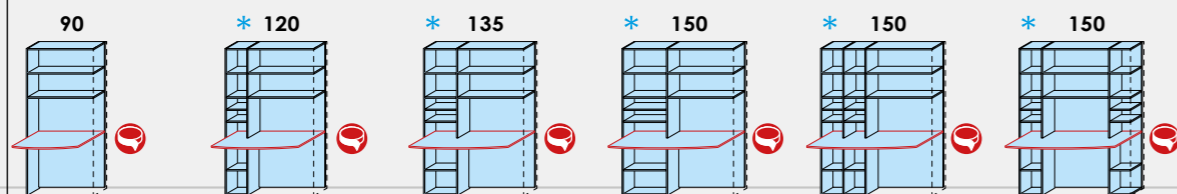

Code	PL92.60E	PL92.61M	PL92.62T	PL92.63Z	PL92.64F	PL92.65N
------	----------	----------	----------	----------	----------	----------

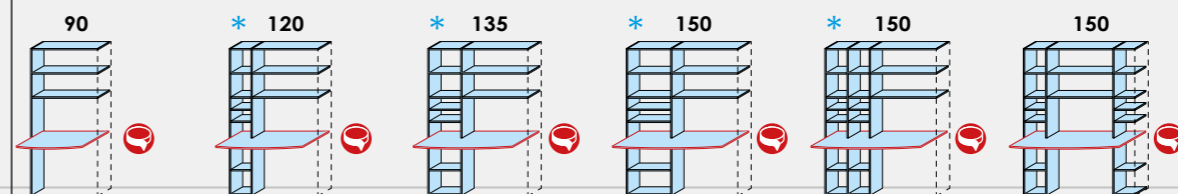

Code	PL92.80R	PL92.81X	PL92.82D	PL92.83L	PL92.84S	PL92.85Y
------	----------	----------	----------	----------	----------	----------

Ht 194.5	PL86.29F
----------	----------

Ht 227.3

\* Specify hinge R or L

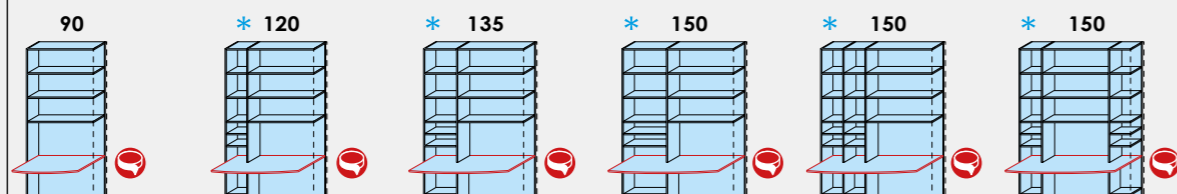

Code	PL92.66U	PL92.67A	PL92.68G	PL92.69P	PL92.70L	PL92.71S
------	----------	----------	----------	----------	----------	----------

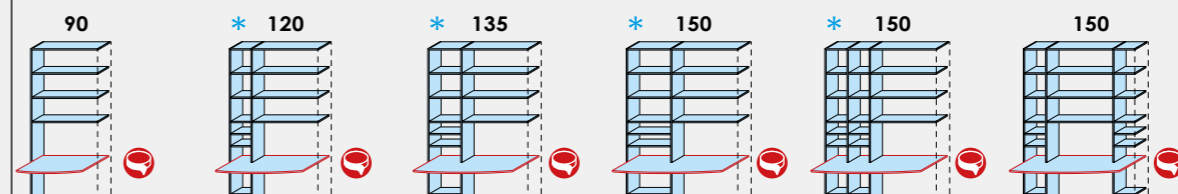

Code	PL92.86E	PL92.87M	PL92.88T	PL92.89Z	PL92.90W	PL92.91C
------	----------	----------	----------	----------	----------	----------

Ht 226.5	PL86.30C	PL85.96V
Customised side panel for ceiling fixing Ht room (Max 302 Min 230)		

Ht 259.3

\* Specify hinge R or L

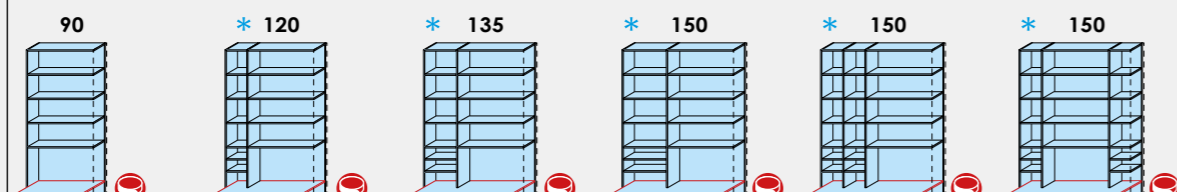

Code	PL92.72Y	PL92.73E	PL92.74M	PL92.75T	PL92.76Z	PL92.77F
------	----------	----------	----------	----------	----------	----------

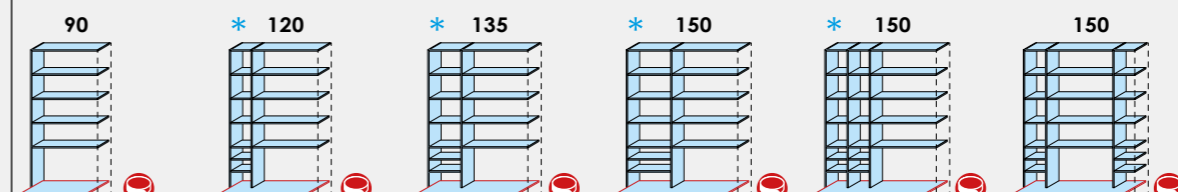

Code	PL92.92K	PL92.93R	PL92.94X	PL92.95D	PL92.96L	PL92.97S
------	----------	----------	----------	----------	----------	----------

Ht 258.5	PL86.31K	PL85.96V
Customised side panel for ceiling fixing Ht room (Max 302 Min 230)		

Backs Th 1.8

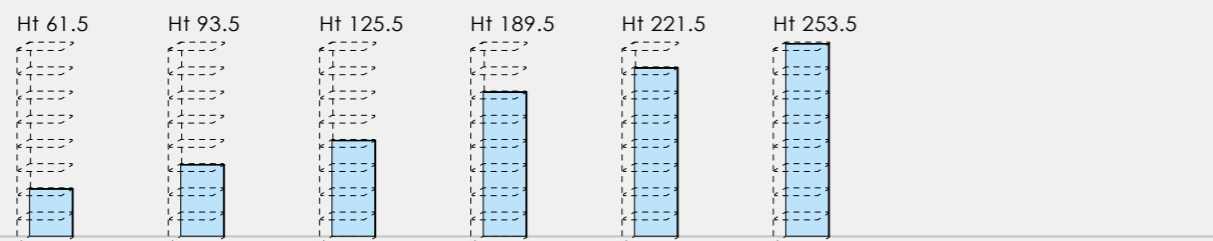

W 30	Code	-	-	-	PL85.69Y	PL85.70V	PL85.71B
W 45	Code	-	-	-	PL85.77R	PL85.78X	PL85.79D
W 60	Code	-	-	-	PL85.85H	PL85.86Q	PL85.87W
W 90	Code	PL85.89K	PL85.90F	PL85.91N	PL85.93A	PL85.94G	PL85.95P

- Components in GROUP 2 colors
- A For bookcases with back
- B For see-through bookcases
- Components available with contrasting edging.

The side panel is equipped with adjustable feet (top and bottom) for fixing between floor and ceiling which allow a maximum adjustment of 20 mm. **When ordering it is necessary to indicate the room height (floor-ceiling); the bookcase will be adjusted to size according to the distance detected.** We recommend that you check the room height in more than one point in order to find any excessive differences. With false ceilings you should check that in the event of inflection, the height difference does not exceed the 2 cm maximum adjustable range of the feet.

Movable shelves

	Melamine-coated Th 2.5	In transparent tempered glass Th 0.8	led spotlights Ø 6.5 We provide a power pack (with a surcharge) able to support from 1 to 6 spotlights. 12 volt 1.7 watt.					
	Dpt 30.8 A	Dpt 33.3 B	Dpt 29.8 with led A					
	Dpt 28.5 A	Dpt 28.5 with led A	Dpt 28.5 with led A					
W 27.5	Code	PL86.00M	PL86.01T	-	-	-		
W 42.5	Code	PL86.02Z	PL86.03F	PL86.04N	PL86.05U	PL86.06A		
W 57.5	Code	PL86.07G	PL86.08P	PL86.09V	PL86.10S	PL86.11Y		
W 87.5	Code	PL86.12E	PL86.13M	PL86.14T	PL86.15Z	PL86.16F		
						Code	PL86.17N	
							Code	PL86.18U

We provide a power pack (with a surcharge) able to support from 1 to 6 shelves W 45/60 or from 1 to 4 shelves W 90

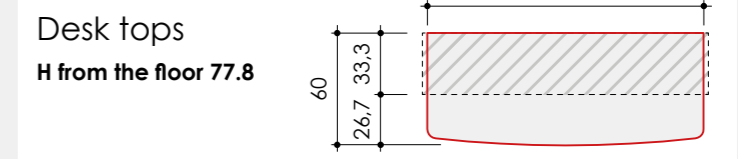

# Self standing bookcases Dpt 33.3 - With peninsula

**Ht 195.3**

Specify hinge  
R or L

<b>Code</b>	PL93.00B	PL93.01H	PL93.02Q	PL93.03W	PL86.29F	
-------------	----------	----------	----------	----------	----------	--

**Ht 227.3**

Specify hinge  
R or L

<b>Code</b>	PL93.04C	PL93.05K	PL93.06R	PL93.07X	PL86.30C	PL85.96V
-------------	----------	----------	----------	----------	----------	----------

**Ht 259.3**

Specify hinge  
R or L

<b>Code</b>	PL93.08D	PL93.09L	PL93.10G	PL93.11P	PL86.31K	PL85.96V
-------------	----------	----------	----------	----------	----------	----------

**Backs  
Th 1.8**

	Ht 29.5	Ht 61.5	Ht 93.5	Ht 125.5	Ht 189.5	Ht 221.5	Ht 253.5
<b>Code</b>	PL85.72H	PL85.73Q	PL85.74W	PL85.75C	PL85.77R	PL85.78X	PL85.79D
<b>W 45</b>							

- Components in **GROUP 2 colors**
- Completed by selecting one of the **Supports for peninsula tops**
- For bookcases with back
- For see-through bookcases
- Components available with contrasting edging
- B17A GZ8T GV7A CQ3Q B14B BO7H CP4J RB7Y CR5T AL1A
- B17A AL1A
- B17A

The side panel is equipped with adjustable feet (top and bottom) for fixing between floor and ceiling which allow a maximum adjustment of 20 mm. **When ordering it is necessary to indicate the room height (floor-ceiling); the bookcase will be adjusted to size according to the distance detected.** We recommend that you check the room height in more than one point in order to find any excessive differences. With false ceilings you should check that in the event of inflection, the height difference does not exceed the 2 cm maximum adjustable range of the feet.

We provide a power pack (with a surcharge) able to support from 1 to 6 shelves W 45/60 or from 1 to 4 shelves W 90

**Side panels on floor  
Dpt 33.3 - Th 2.5**  
(Ht 0.8 foot not included)

## Supports for peninsula tops

Metal leg	POP leg	TRIS leg	SLIM leg	BIT leg	HEY leg
Ht 75,1 Ø 8 Base Ø 23	W 20 Ht 75,1 Dpt 43,3	W 11,8 Ht 75,1	W 7 Ht 75,1 Th 2	W 46 Ht 75,1	W 5 Ht 75,1 Th 43,5

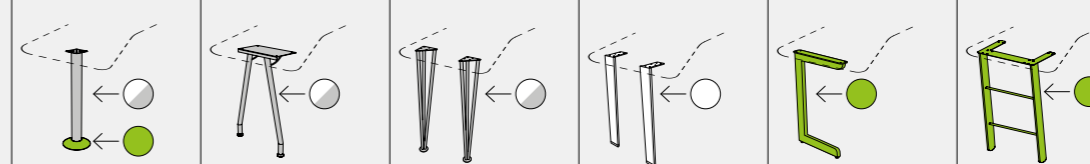

<b>Code</b>	P28.86N	P07.98V	P07.75V	P07.74Q	P08.02B	PK46.67Z
-------------	---------	---------	---------	---------	---------	----------

**Desk tops**  
H from the floor 77.8

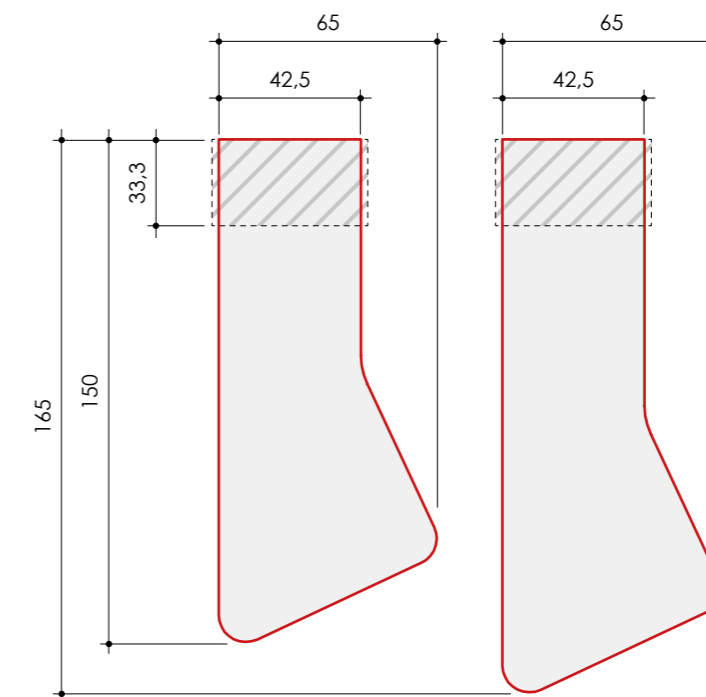

**Movable shelves**

	Melamine-coated Th 2,5	In transparent tempered glass Th 0,8	<b>led spotlights Ø 6.5</b> We provide a power pack (with a surcharge) able to support from 1 to 6 spotlights. 12 volt 1.7 watt.		
	Dpt 30.8 	Dpt 33.3 			
	Dpt 29.8 with led 	Dpt 28.5 			
	Dpt 28.5 with led 	Dpt 28.5 with led 			
<b>Code</b>	PL86.02Z	PL86.03F	PL86.04N	PL86.05U	PL86.06A
<b>W 42.5</b>					

**Wireless switch**  
For led lighting (usable for shelves and for spotlight).

**Code** PL86.18U

**OPTIONAL:** C - Extra colors for Metal leg disc  
p. 409



# Self standing bookcases Dpt 33.3 - With TV compartment

With back panel

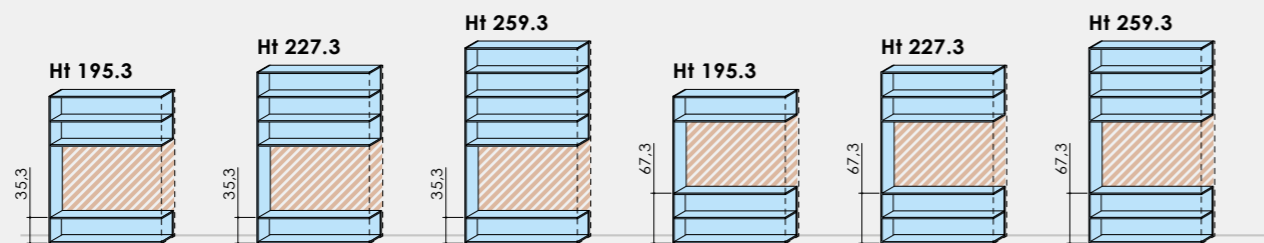

W 120	Code	PL93.20N	PL93.21U	PL93.22A	PL93.23G	PL93.24P	PL93.25V
W 150	Code	PL93.26B	PL93.27H	PL93.28Q	PL93.29W	PL93.30T	PL93.31Z
W 180	Code	PL93.32F	PL93.33N	PL93.34U	PL93.35A	PL93.36G	PL93.37P

See-through

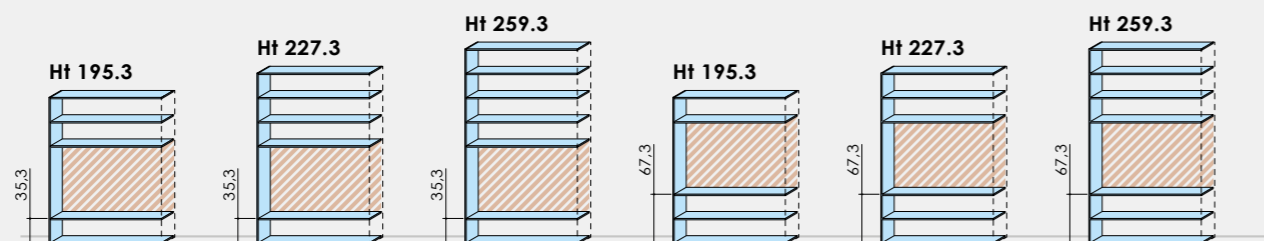

W 120	Code	PL93.40Y	PL93.41E	PL93.42M	PL93.43T	PL93.44Z	PL93.45F
W 150	Code	PL93.46N	PL93.47U	PL93.48A	PL93.49G	PL93.50D	PL93.51L
W 180	Code	PL93.52S	PL93.53Y	PL93.54E	PL93.55M	PL93.56T	PL93.57Z

TV compartments with lighting system

Always order one for every composition.

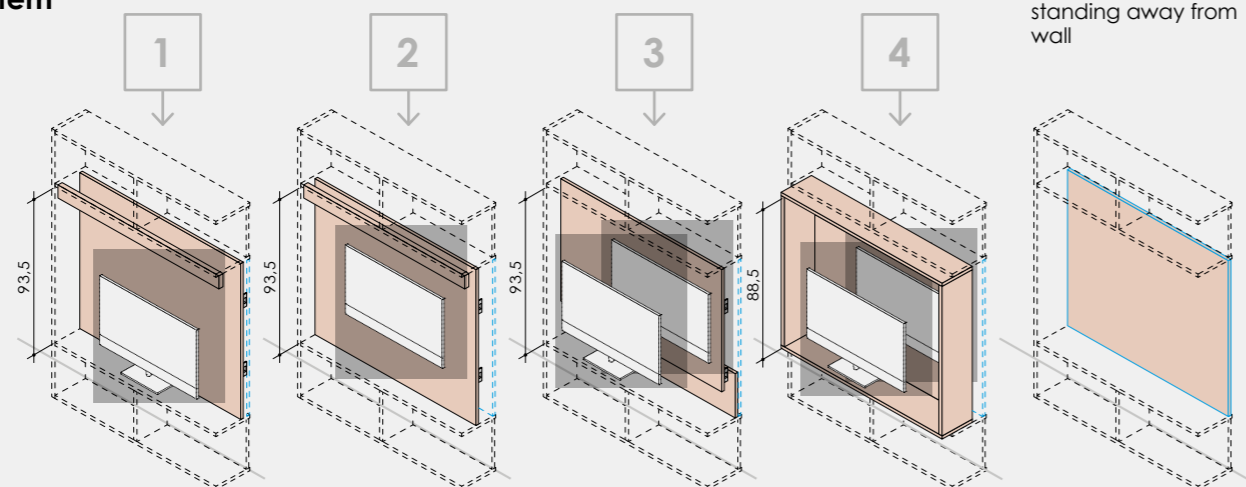

W 120	Code	PL93.60K	PL93.61R	PL93.62X	PL93.63D	PL93.64L
W 150	Code	PL93.65S	PL93.66Y	PL93.67E	PL93.68M	PL93.69T
W 180	Code	PL93.70Q	PL93.71W	PL93.72C	PL93.73K	PL93.74R

- Components in **GROUP 2 colors**
- Components in **GROUP 3 colors**
- A For bookcases with back
- B For see-through bookcases

▶ The side panel is equipped with adjustable feet (top and bottom) for fixing between floor and ceiling which allow a maximum adjustment of 20 mm. **When ordering it is necessary to indicate the room height (floor-ceiling); the bookcase will be adjusted to size according to the distance detected.** We recommend that you check the room height in more than one point in order to find any excessive differences. With false ceilings you should check that in the event of inflection, the height difference does not exceed the 2 cm maximum adjustable range of the feet.

Backs Th 1.8

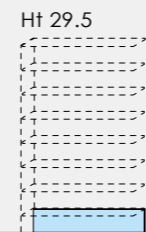

W 117.5	Code	PL87.50T		
W 147.5	Code	PL87.51Z		
W 177.5	Code	PL87.52F		

Side panels on floor Dpt 33.3 - Th 2.5

(H 0.8 foot not included)

Customised side panel for ceiling fixing  
Ht room (Max 302 Min 230)

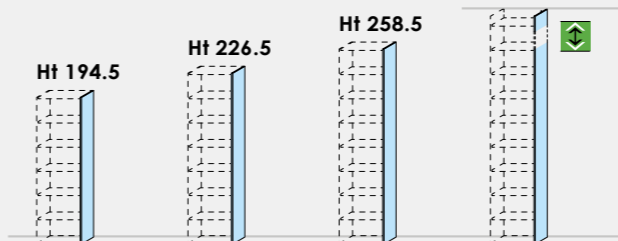

Code	PL86.29F	PL86.30C	PL86.31K	PL85.96V
	60,00	72,00	79,00	105,00

Dividing panel positioning instructions

The grid in each horizontal section is divided every 15 cm. Dividing panels must be mounted following the instruction below:  
**SIDE compartments L Max 73.8 - Min 28.8 cm.**  
**MIDDLE compartments L Max 75 - Min 30 cm.**  
The position of **load-bearing** dividing panels establishes the holes on the above and below shelves.

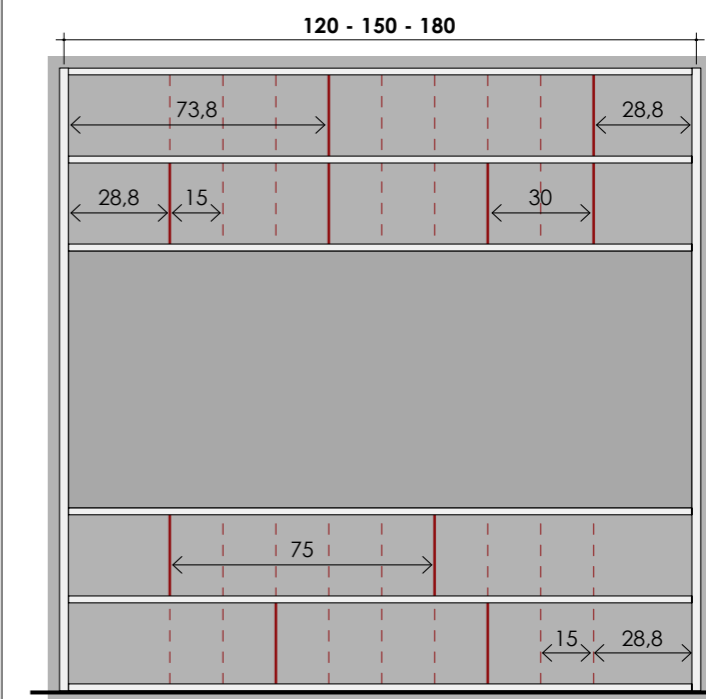

Melamine-faced dividing panels Ht 29.5 - Th 2.5

Load-Bearing

Can be equipped with standard doors and drawers.

Code	SHARE Dpt 30.8		SHARE Dpt 33.3		ELLE Dpt 30.8 Th 2.5		SEPARÉ Dpt 30.8 Th 2.5	
	W	Code	W	Code	W	Code	W	Code
	30	PL87.72S	32.5	PL87.77Z				
	45	PL87.73Y	47.5	PL87.78F				
	60	PL87.74E	62.5	PL87.79N				
	75	PL87.75M	77.5	PL87.80K				
	90	PL87.76T	92.5	PL87.81R				

Movable shelves

use with dividing panels SHARE

Code	Melamine-coated Th 2.5		In transparent tempered glass Th 0.8		led spotlights Ø 6.5	
	Dpt 30.8	Dpt 33.3	Dpt 29.8 with led	Dpt 28.5 with led		
W 27.5	Code	PL86.00M	PL86.01T	-	Code	PL86.17N
W 42.5	Code	PL86.02Z	PL86.03F	PL86.04N	PL86.05U	PL86.06A
W 57.5	Code	PL86.07G	PL86.08P	PL86.09V	PL86.10S	PL86.11Y
W 87.5	Code	PL86.12E	PL86.13M	PL86.14T	PL86.15Z	PL86.16F

W 27.5	Code	PL86.00M	PL86.01T	-	-	-
W 42.5	Code	PL86.02Z	PL86.03F	PL86.04N	PL86.05U	PL86.06A
W 57.5	Code	PL86.07G	PL86.08P	PL86.09V	PL86.10S	PL86.11Y
W 87.5	Code	PL86.12E	PL86.13M	PL86.14T	PL86.15Z	PL86.16F

■ We provide a power pack (with a surcharge) able to support from 1 to 6 shelves W 45/60 or from 1 to 4 shelves W 90

**Wireless switch**  
For led lighting (usable for shelves and for spotlight).

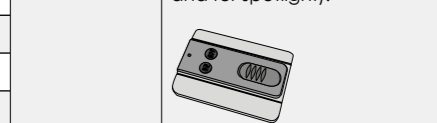

Code PL86.18U

# Self standing bookcases Dpt 33.3 - With 180° rotating TV compartment

With back panel

	Ht 195.3	Ht 227.3	Ht 259.3	Customised bookcase for ceiling fixing. Ht room (Max 302 Min 230)
W 120	Code PK86.00K	PK86.01R	PK86.02X	PK86.03D

See-through

	Ht 195.3	Ht 227.3	Ht 259.3	Customised bookcase for ceiling fixing. Ht room (Max 302 Min 230)
W 120	Code PK86.04L	PK86.05S	PK86.06Y	PK86.07E

\* Compartment to be completed with doors and/or back, see below:

	Doors Ht 32	Folding door Ht 32	Back Th 1.8 - Ht 29.5	
Code	PK86.08M	PK84.07W	PL87.50T	
ONE				
CLUB				
WINDOW				

Side panels on floor Dpt 33.3 - Th 2.5  
(H 0.8 foot not included)

	Ht 194.5	Ht 226.5	Ht 258.5	Customised side panel for ceiling fixing. Ht room (Max 302 Min 230)
Code	PL86.29F	PL86.30C	PL86.31K	PL85.96V

Movable shelves

	Melamine-coated Th 2,5	In transparent tempered glass Th 0,8				
	Dpt 30.8	Dpt 33.3	Dpt 29.8 with led	Dpt 28.5	Dpt 28.5 with led	
W 57.5	Code	PL86.07G	PL86.08P	PL86.09V	PL86.10S	PL86.11Y

led spotlights Ø 6.5

We provide a power pack (with a surcharge) able to support from 1 to 6 spotlights. 12 volt 1.7 watt.



Wireless switch

For led lighting (usable for shelves and for spotlight).

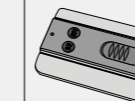

Code	PL86.17N	PL86.18U				
------	----------	----------	--	--	--	--

We provide a power pack (with a surcharge) able to support from 1 to 6 shelves W 45/60 or from 1 to 4 shelves W 90

- Components in GROUP 2 colors
- Components in GROUP 3 colors
- For bookcases with back
- For see-through bookcases

The side panel is equipped with adjustable feet (top and bottom) for fixing between floor and ceiling which allow a maximum adjustment of 20 mm. **When ordering it is necessary to indicate the room height (floor-ceiling); the bookcase will be adjusted to size according to the distance detected.** We recommend that you check the room height in more than one point in order to find any excessive differences. With false ceilings you should check that in the event of inflection, the height difference does not exceed the 2 cm maximum adjustable range of the feet.

p. 56 Knob and handle positions  
p. 732 Doors INFINITY  
p. 735 Drawers INFINITY

p. 736 Sliding doors INFINITY



# Self standing bookcases Dpt 33.3 - With CLICK foldaway beds W 80 base

The save space CLICK must be fixed to the wall with the supplied hardware. Wall anchors are not included; the choice of the type of anchor to be used must be made by the fitter based on the characteristics of the wall.

## Single bed

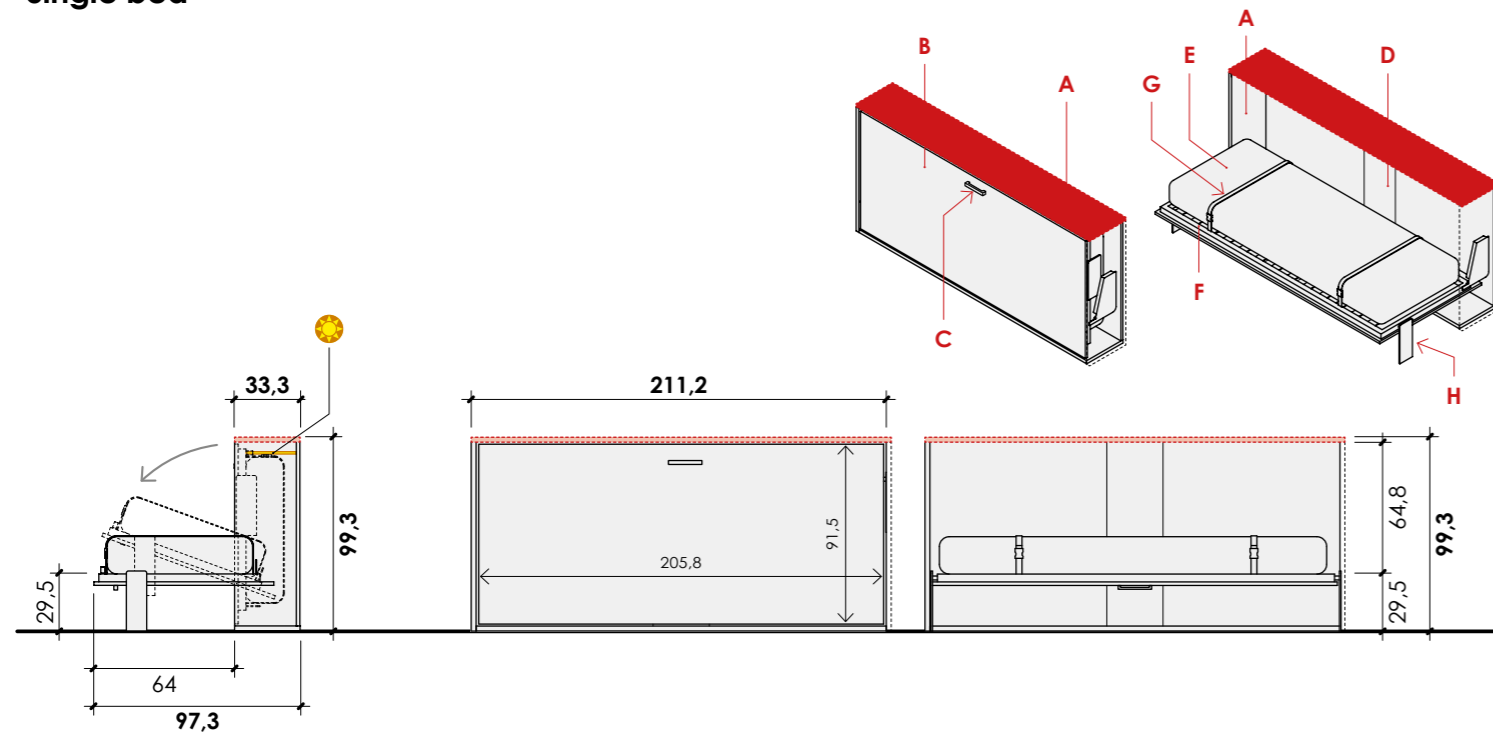

## Single bed on bookcase

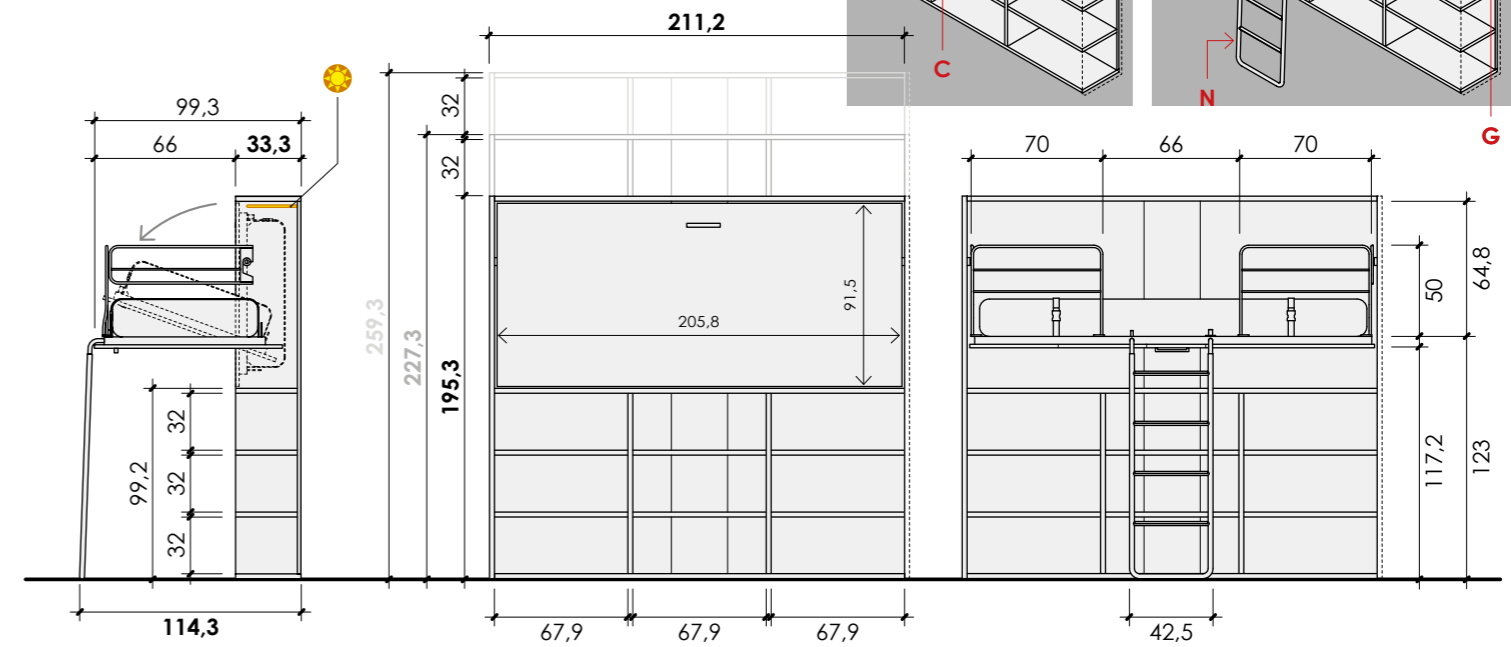

### Single bed

W 211,2

Ht 96,8

\* To be completed with Top Th 2.5

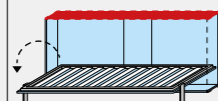

Code **PL85.00E**

Use the: mattress 200 x 80

Without light

With light Specify R or L

### Single bed on bookcase

W 211,2

Ht 195,3

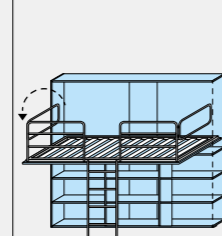

Code **PL85.01M**

Ht 227,3

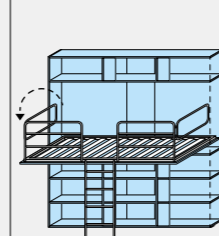

Code **PL85.02T**

Ht 259,3

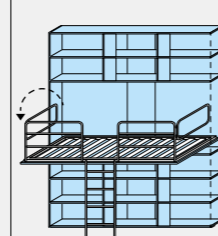

Code **PL85.03Z**

## 2 single beds

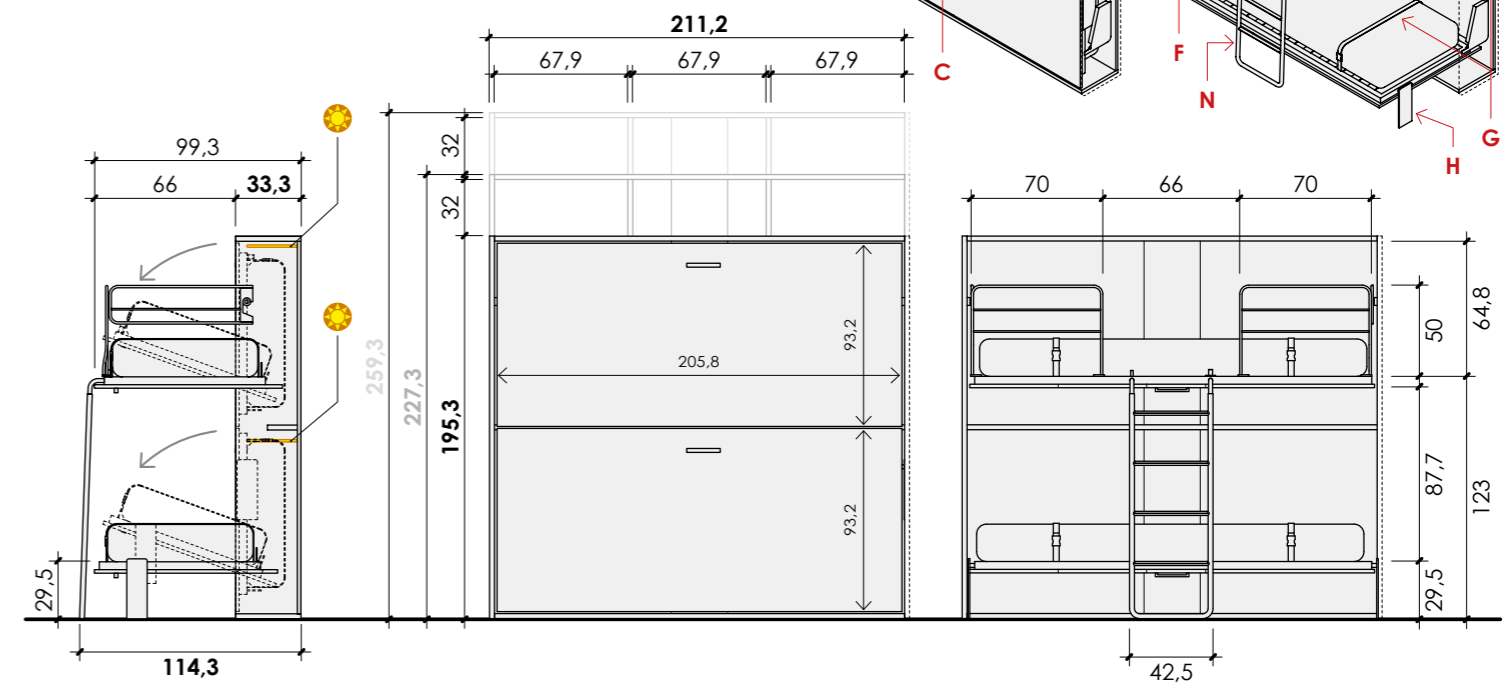

### 2 single beds

W 211,2

Ht 195,3

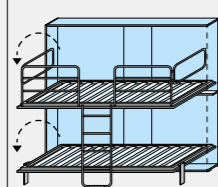

Code **PL85.04F**

Use the: mattress 200 x 80

Without light

With light Specify R or L

Ht 227,3

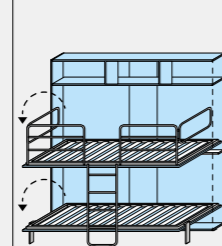

Code **PL85.05N**

Ht 259,3

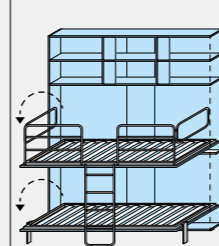

Code **PL85.06U**

Components in **GROUP 2** colors

- A Structure Th 2.5
- B Front panels Th 1.8
- C Horizontal handle, to be chosen among those 160 mm pitch (MIRA G88N excluded)
- D Backboard Th 1.8
- E Mattress
- F Slatted base
- G Mattress clips
- H Fold-down feet
- I Feet/shelf
- L Padded headboard (optional)
- M Fold-down metal protection
- N Removable metal ladder
- O Sofa
- P Feet/desk top
- Q Tipper table with metallic structure in Champagne color
- R Anti tipping lock

### Led lighting

The space save beds can be fitted with an internal light on the side (flush-fit), inserted into a dedicated slot. It has a built-in touch switch and transformer (12V 10W).

- Single beds with bed base W 80 can be equipped with 1 light (specify R or L).
- The two single beds with bed base W 80 can be equipped with 2 lights, for the top and bottom bed, both on the same side (specify RH or LH).

Mattresses, pillows and slatted bed base

See back cover wing



# Self standing bookcases Dpt 33.3 - With CLICK foldaway beds W 120 base

# Self standing bookcases Dpt 33.3 - With CLICK foldaway beds W 140 base

The save space CLICK must be fixed to the wall with the supplied hardware. Wall anchors are not included; the choice of the type of anchor to be used must be made by the fitter based on the characteristics of the wall.

The save space CLICK must be fixed to the wall with the supplied hardware. Wall anchors are not included; the choice of the type of anchor to be used must be made by the fitter based on the characteristics of the wall.

## Single bed + writing desk Dpt 50

The front panels consist of adjacent panels in different sizes. The position of the panels is fixed (as shown). The colour of the panels can be customised to customer's choice.

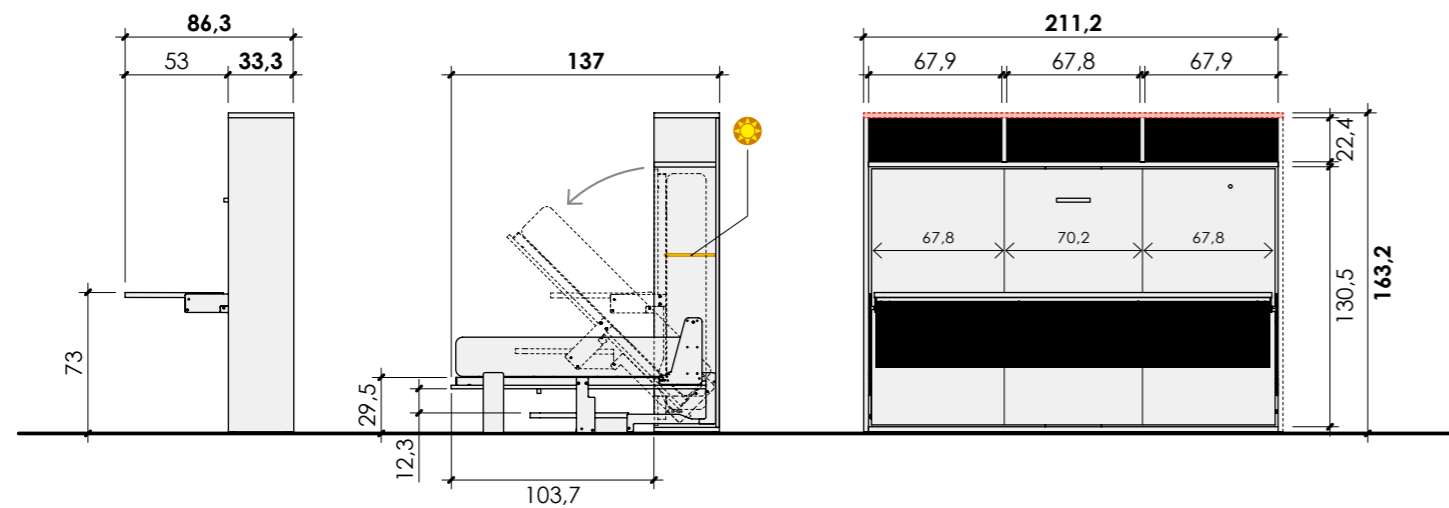
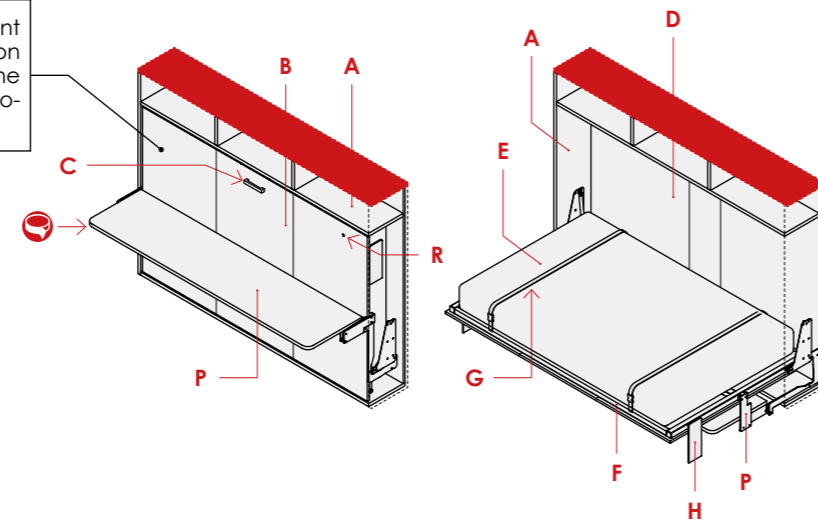

## Single bed

## Single bed + shelf Dpt 26

The front panels consist of adjacent panels in different sizes. The position of the panels is fixed (as shown). The colour of the panels can be customised to customer's choice.

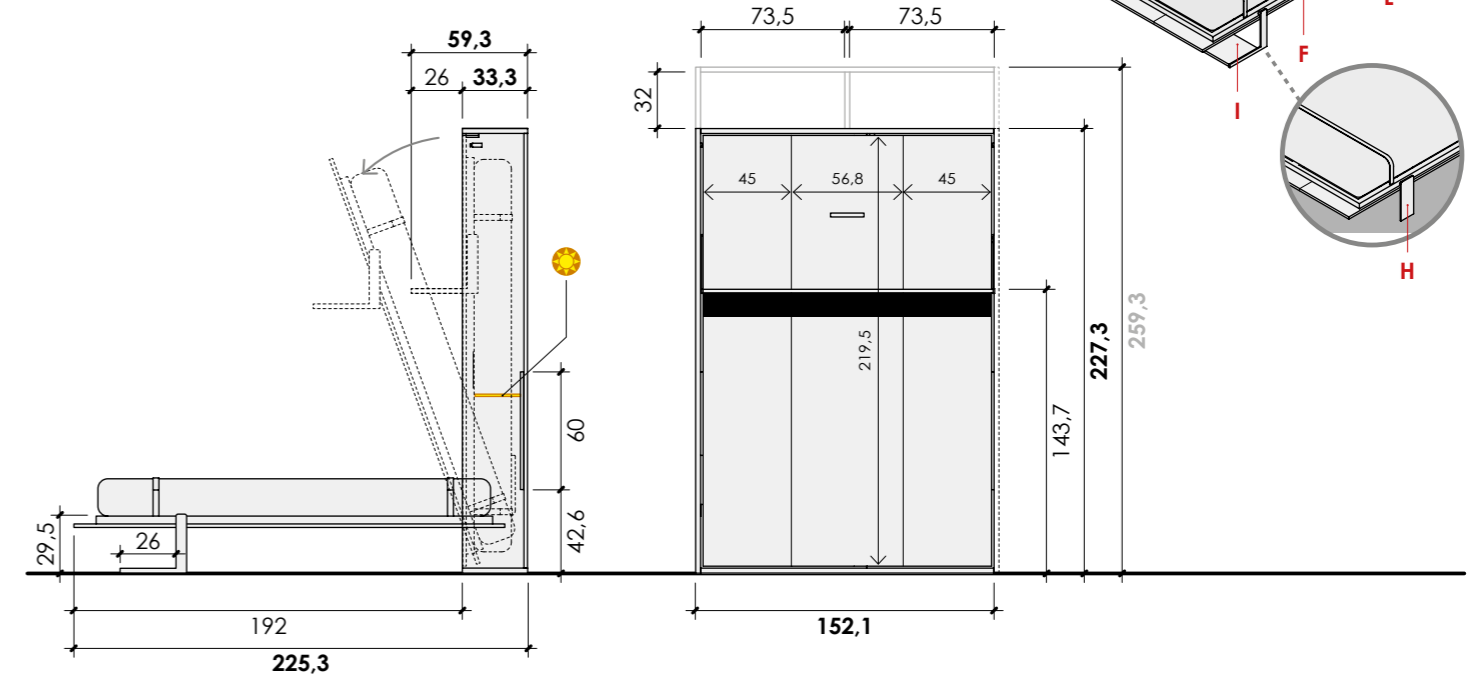
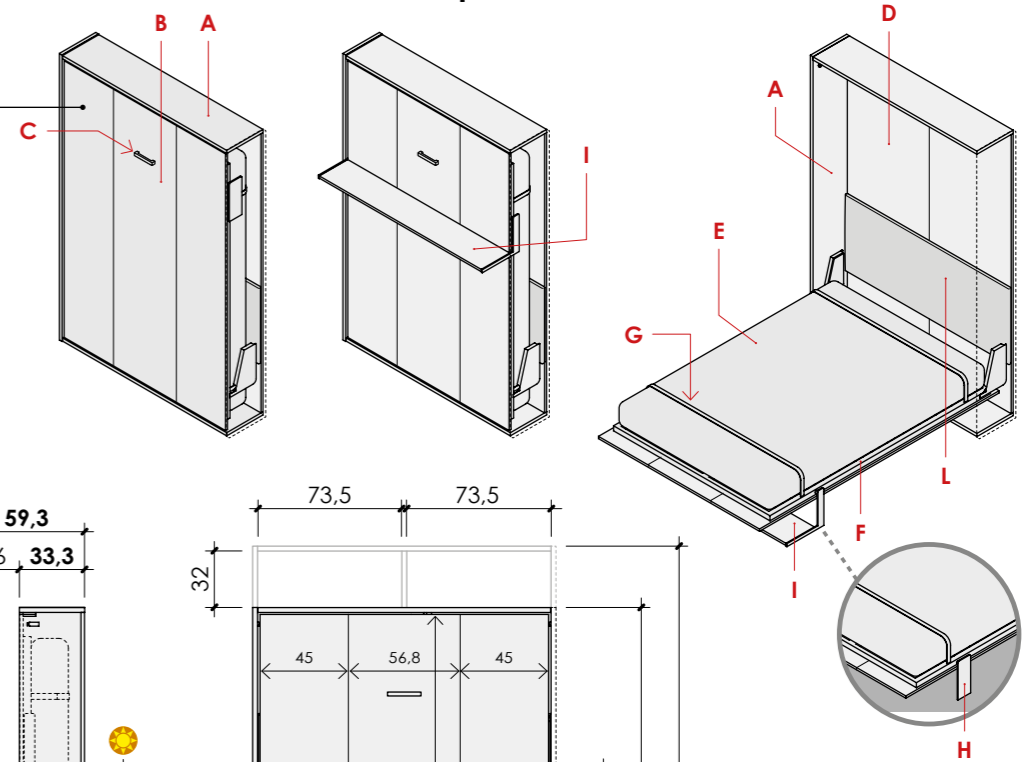

## Single bed + writing desk Dpt 50

W 211,2  
Ht 160,7

\* To be completed with Top Th 2.5

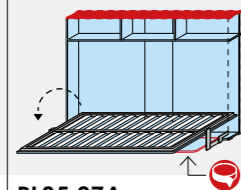

Use the: mattress 200 x 120

<b>Code</b>	<b>PL85.07A</b>		
Without light			
With light	Specify R or L		

Components in **GROUP 2 colors**

Shaped components available with contrasting edging.



- A** Structure Th 2.5
- B** Front panels Th 1.8
- C** Horizontal handle, to be chosen among those 160 mm pitch (MIRA G88N excluded)
- D** Backboard Th 1.8
- E** Mattress
- F** Slatted base
- G** Mattress clips
- H** Fold-down feet
- I** Feet/shelf
- L** Padded headboard (optional)
- M** Fold-down metal protection
- N** Removable metal ladder
- O** Sofa
- P** Feet/desk top
- Q** Tipper table with metallic structure in Champagne color
- R** Anti tipping lock

## Single beds

W 152,1  
Ht 227,3

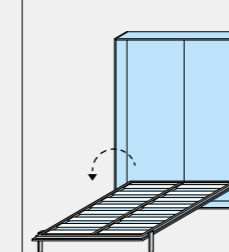

Use the: mattress 200 x 140

<b>Code</b>	<b>PL85.08G</b>	<b>PL85.09P</b>	<b>PL85.10L</b>	<b>PL85.11S</b>	<b>PL87.49W</b>
Without light					248,00
With light					

Ht 259,3

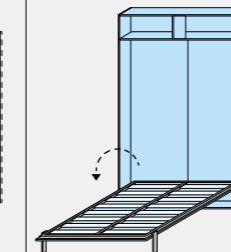

## Single beds + shelf Dpt 26

W 152,1  
Ht 227,3

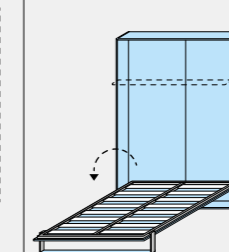

Ht 259,3

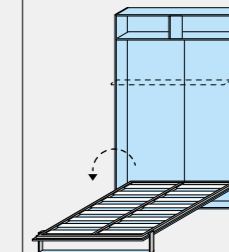

## Padded headboard

Ht 60  
Th 2,5

Only with H 17 mattresses

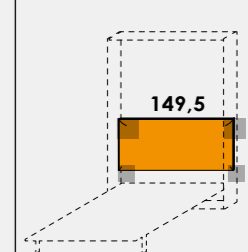

## Led lighting

The space save beds can be fitted with an internal light on the side (flush-fit), inserted into a dedicated slot. It has a built-in touch switch and transformer (12V 10W).

- Single beds with bed base W 120 can be equipped with 1 light (specify R or L).
- The single beds with bed base W 140 can be equipped with 2 lights, always on both sides.

Mattresses, pillows and slatted bed base  
See back cover wing



p. 745 Side panels on floor and Top Dpt 33.3 - Th 2.5

# Self standing bookcases Dpt 33.3 - With CLICK foldaway beds W 160 base - (A)

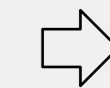

The save space CLICK must be fixed to the wall with the supplied hardware. Wall anchors are not included; the choice of the type of anchor to be used must be made by the fitter based on the characteristics of the wall.

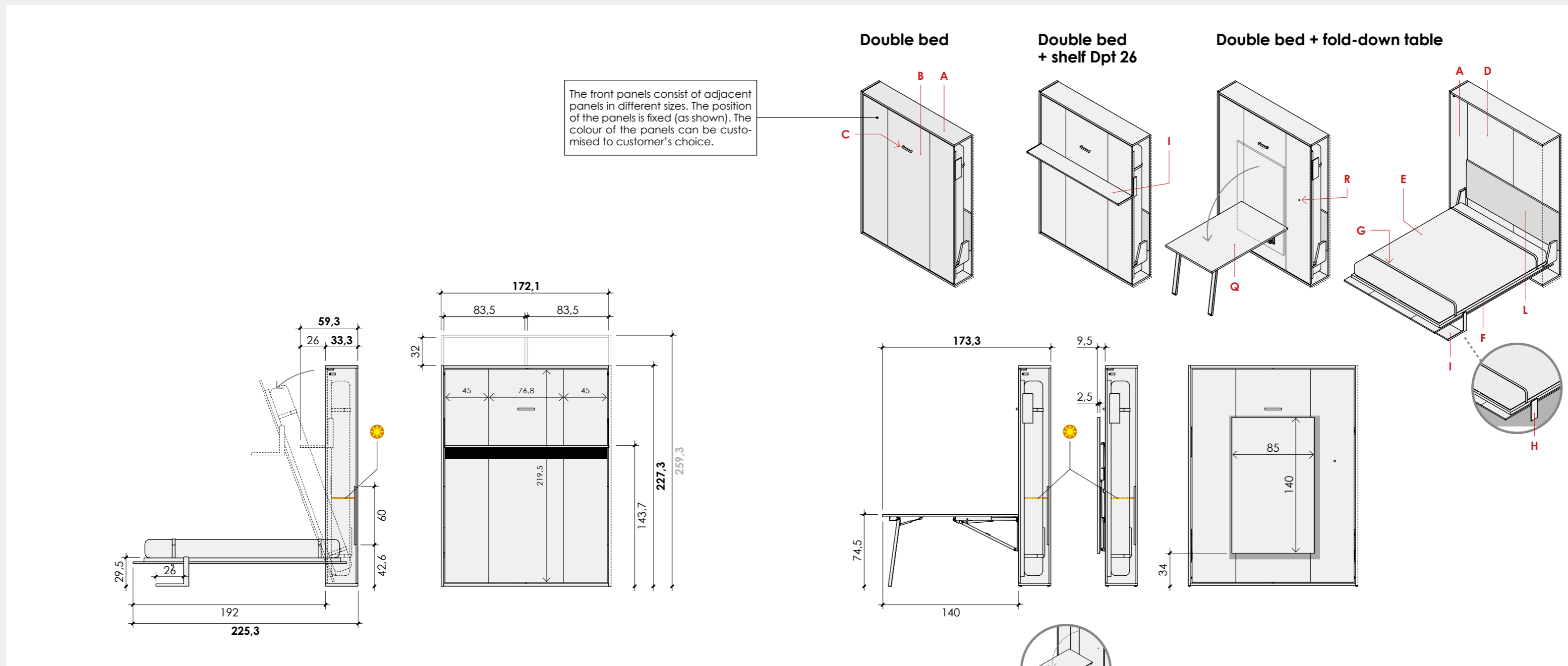

	Double beds		Double beds + shelf Dpt 26		Double beds + fold-down table		Padded headboard
	W 172,1	Ht 259,3	W 172,1	Ht 259,3	W 172,1	Ht 259,3	Only with H 17 mattresses Ht 60 Th 2,5
	Ht 227,3		Ht 227,3		Ht 227,3		
<b>Code</b>	<b>PL85.12Y</b>	<b>PL85.13E</b>	<b>PL85.14M</b>	<b>PL85.15T</b>	<b>PL85.16Z</b>	<b>PL85.17F</b>	<b>PL86.45R</b>
Without light							
With light							

Use the: mattress 200 x 160

Components in GROUP 2 colors

FABRIC JENNY	0402	0403	0503	0900	0903	0905	0314	0303	0805	0706	0704	0601	0604
FABRIC KENYA	0014	0013	0016	0020	0019								
FALIX LEATHER TAPE	0111	0102	0603	0415	0503	0605	0700	0608	0901				

- A Structure Th 2.5
- B Front panels Th 1.8
- C Horizontal handle, to be chosen among those 160 mm pitch (MIRA G88N excluded)
- D Backboard Th 1.8
- E Mattress
- F Slatted base
- G Mattress clips
- H Fold-down feet
- I Feet/shelf
- L Padded headboard (optional)
- M Fold-down metal protection
- N Removable metal ladder
- O Sofa
- P Feet/desk top
- Q Tipper table with metallic structure in Champagne color
- R Anti tipping lock

**Led lighting**

The space save beds can be fitted with an internal light on the side (flush-fit), inserted into a dedicated slot. It has a built-in touch switch and transformer (12V 10W).

- Double beds (A) can be equipped with 2 lights, always on both sides.

Mattresses, pillows and slatted bed base

See back cover wing

# Self standing bookcases Dpt 33.3 - With CLICK foldaway beds W 160 base - (A)

The save space CLICK must be fixed to the wall with the supplied hardware. Wall anchors are not included; the choice of the type of anchor to be used must be made by the fitter based on the characteristics of the wall.

## Double bed + sofa

Sofa with removable covers

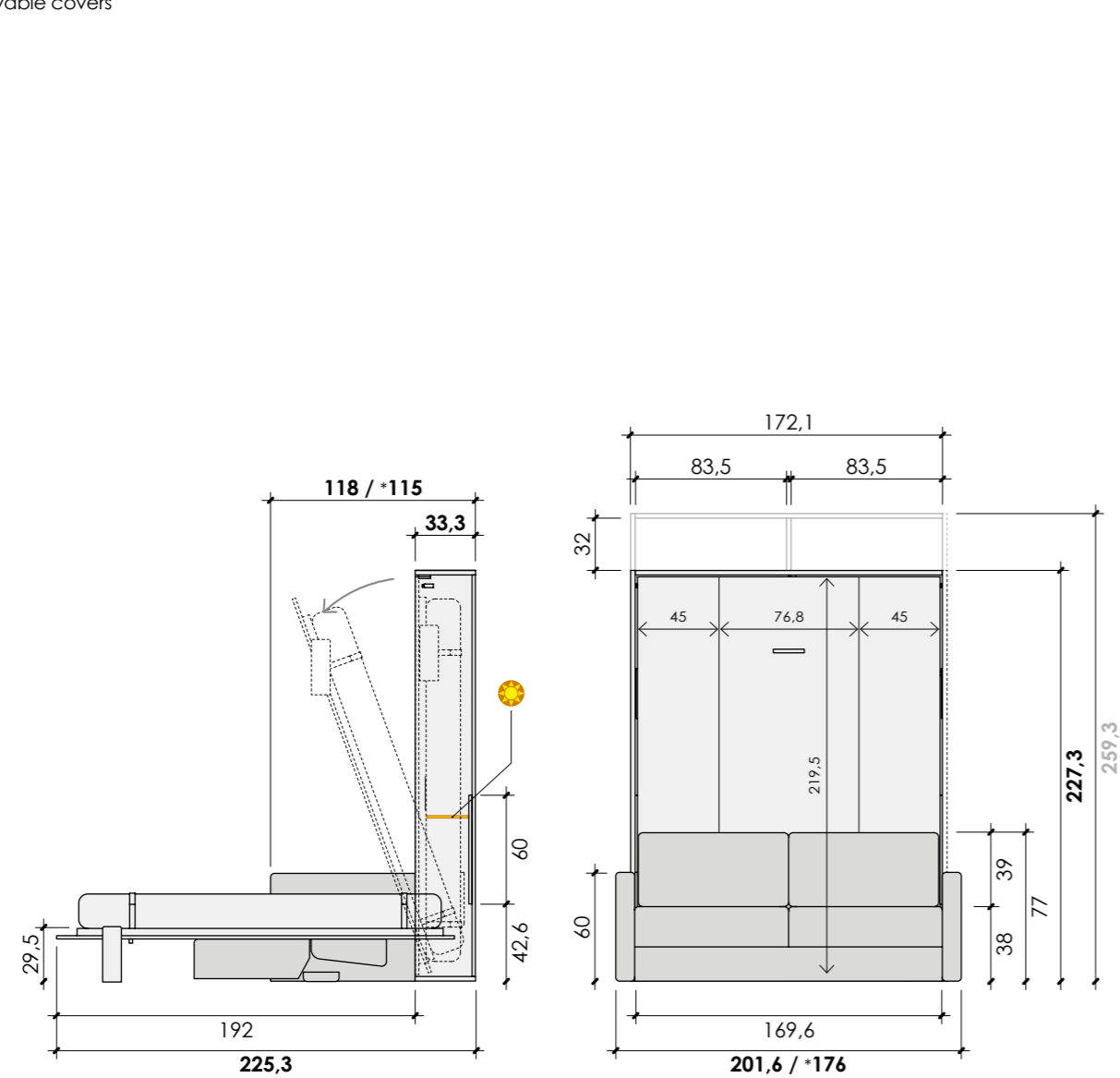

The front panels consist of adjacent panels in different sizes. The position of the panels is fixed (as shown). The colour of the panels can be customised to customer's choice.

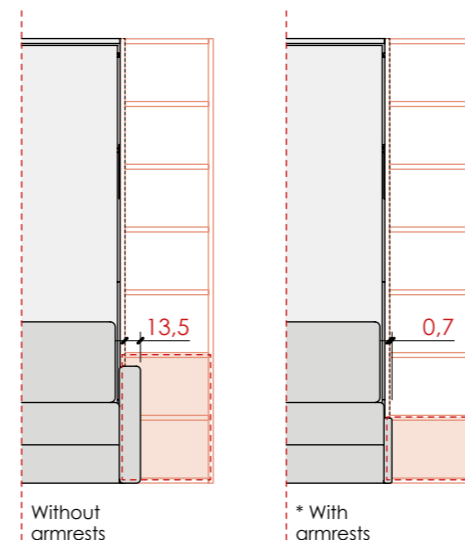
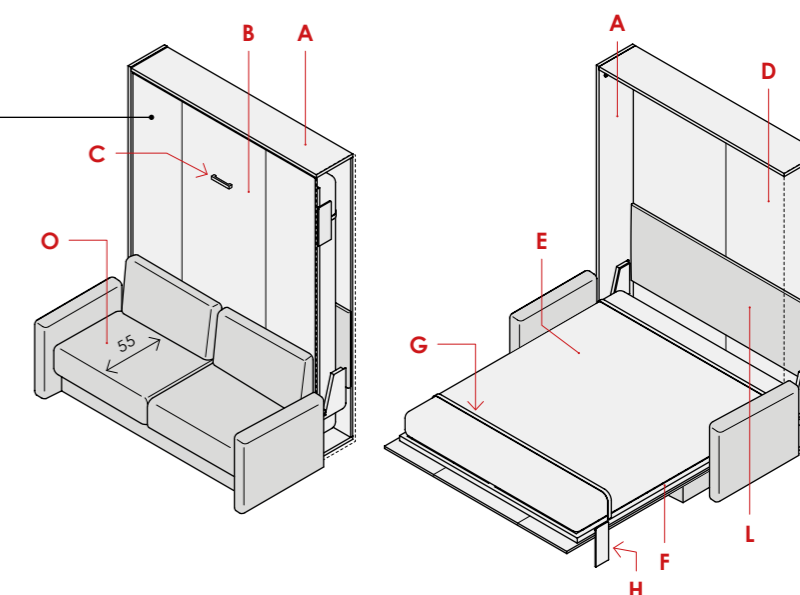

The armrests protrude from the side panels as shown. Compartments in bookcases adjacent to the sofa (highlighted) must always be open.

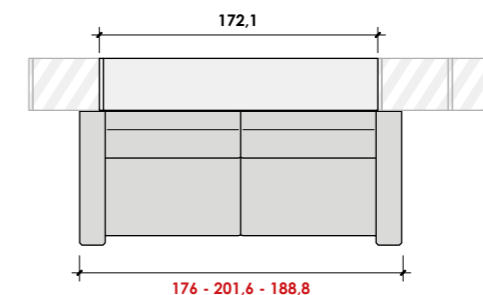

Without armrests

W 172,1  
Ht 227,3

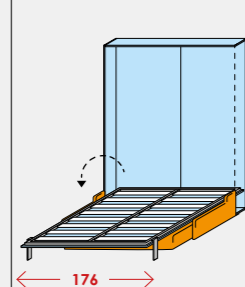

Code **PL85.18N**

Ht 259,3

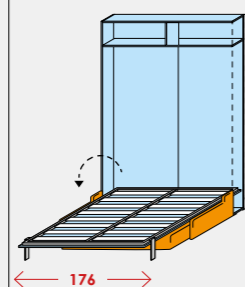

Code **PL85.19U**

With 2 armrests

W 172,1  
Ht 227,3

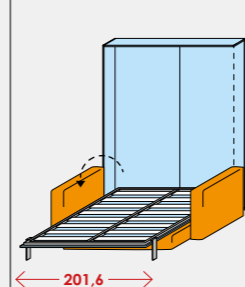

Code **PL85.20R**

Ht 259,3

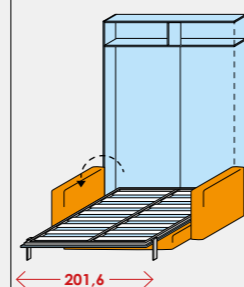

Code **PL85.21X**

With 1 armrest

Specify armrest R or L (drawing shows L)

W 172,1  
Ht 227,3

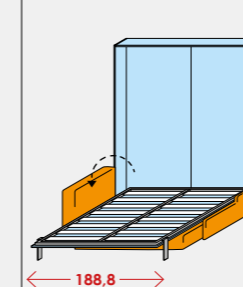

Code **PL85.22D**

Ht 259,3

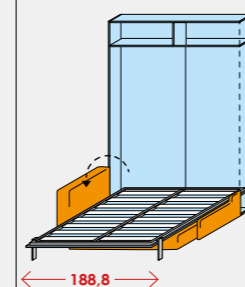

Code **PL85.23L**

Padded headboard

Only with H 17 mattresses

Ht 60  
Th 2,5

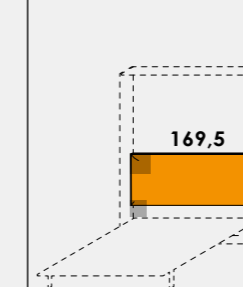

Code **PL86.45R**

Pouf

With removable covers

Dpt 60  
W 60  
Ht 38

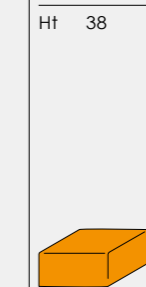

Code **PL86.19A**

Use the: mattress 200 x 160

Code

Without light

With light

Components in GROUP 2 colors



- A Structure Th 2.5
- B Front panels Th 1.8
- C Horizontal handle, to be chosen among those 160 mm pitch (MIRA G88N excluded)
- D Backboard Th 1.8
- E Mattress
- F Slatted base
- G Mattress clips
- H Fold-down feet
- I Feet/shelf
- L Padded headboard (optional)
- M Fold-down metal protection
- N Removable metal ladder
- O Sofa
- P Feet/desk top
- Q Tipper table with metallic structure in Champagne color
- R Anti tipping lock

### Led lighting

The space save beds can be fitted with an internal light on the side (flush-fit), inserted into a dedicated slot. It has a built-in touch switch and transformer (12V 10W).

- Double beds (A) can be equipped with 2 lights, always on both sides.

Mattresses, pillows and slatted bed base

See back cover wing



p. 745 Side panels on floor and Top Dpt 33.3 - Th 2.5



# Self standing bookcases Dpt 33.3 - With CLICK foldaway beds W 160 base - (B)

The save space CLICK must be fixed to the wall with the supplied hardware. Wall anchors are not included; the choice of the type of anchor to be used must be made by the fitter based on the characteristics of the wall.

## Double bed

The front panels consist of adjacent panels in different sizes. The position of the panels is fixed (as shown). The colour of the panels can be customised to customer's choice.

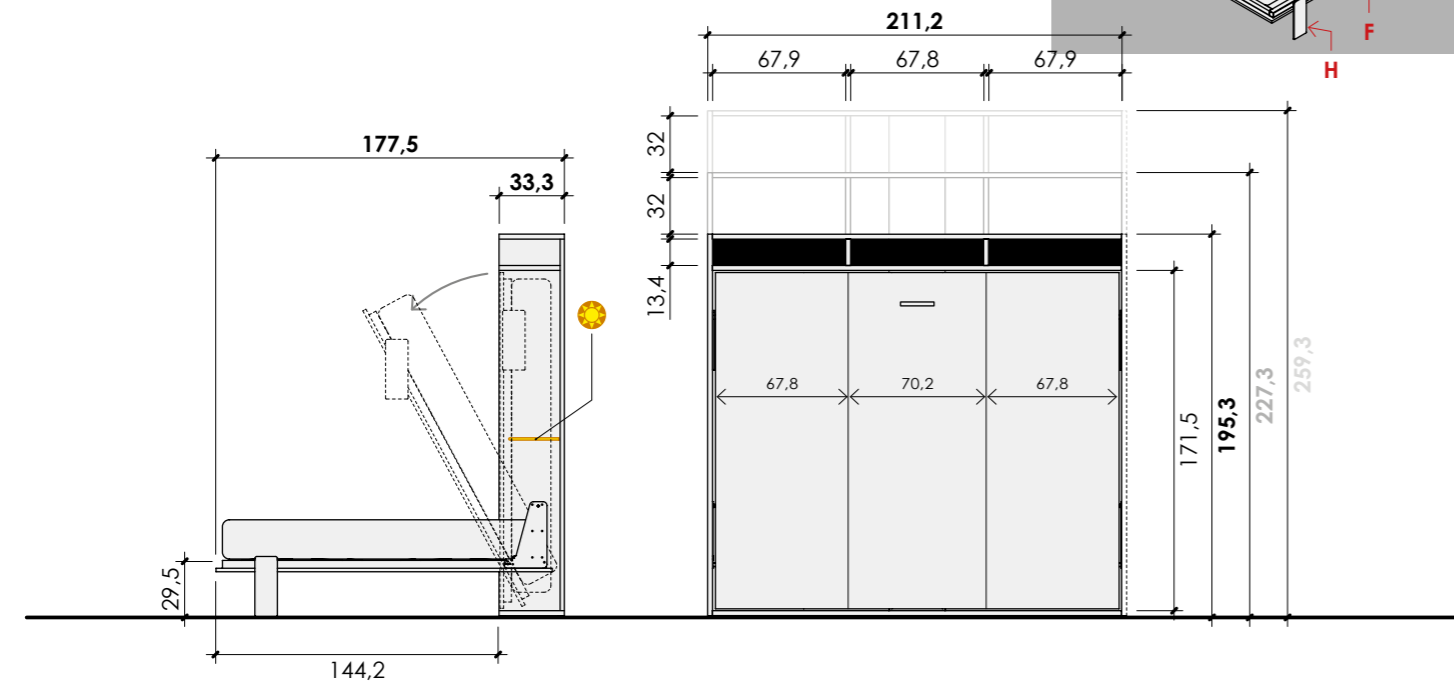
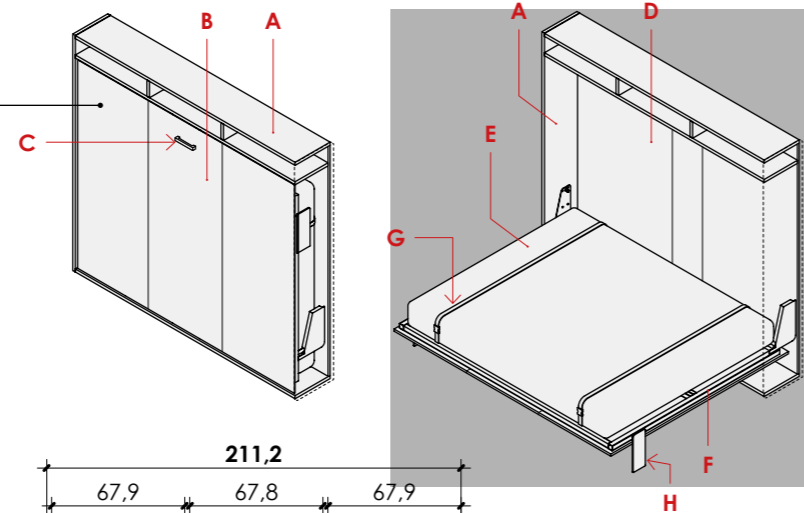

### Double beds

W 211,2  
Ht 195,3

Ht 227,3

Ht 259,3

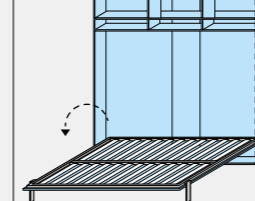
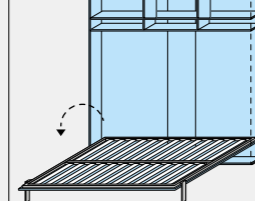
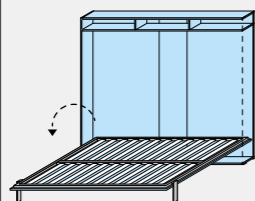

Use the:  
mattress 200 x 160

Code	PL85.24S	PL85.25Y	PL85.26E
Without light			
With light Specify R or L			

Components in **GROUP 2 colors**  
Components in **Types and colors FRONT**

- A Structure Th 2.5
- B Front panels Th 1.8
- C Horizontal handle, to be chosen among those 160 mm pitch (MIRA G88N excluded)
- D Backboard Th 1.8
- E Mattress
- F Slatted base
- G Mattress clips
- H Fold-down feet
- I Feet/shelf
- L Padded headboard (optional)
- M Fold-down metal protection
- N Removable metal ladder
- O Sofa
- P Feet/desk top
- Q Tipper table with metallic structure in Champagne color
- R Anti tipping lock

### Led lighting

The space save beds can be fitted with an internal light on the side (flush-fit), inserted into a dedicated slot. It has a built-in touch switch and transformer (12V 10W).

- Double beds (B) can be equipped with 1 light (specify R or L).



# Self standing bookcases Dpt 45.8 - Dimensions

## WIDTH AND DEPTH

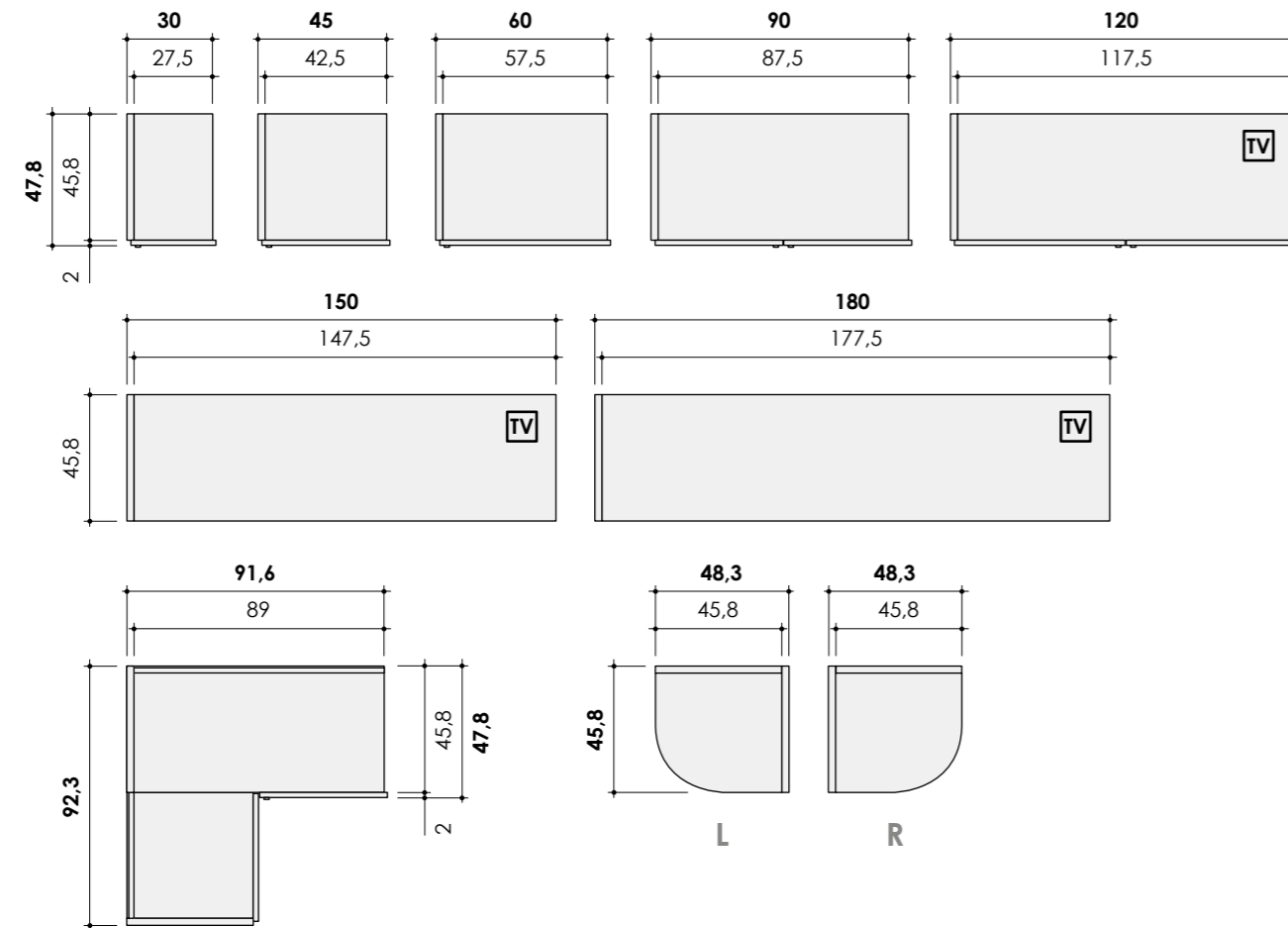

## HEIGHT

The standard distance between each shelf is 32 cm. Upon request, shelves can be positioned every 16 cm.

The last counter-opposing housing space (⊗) cannot be equipped with a back panel and doors.

**SELF STANDING BOOKCASES**  
With top and top finishing insert. Ht 0.8 cm adjustable foot included in heights.

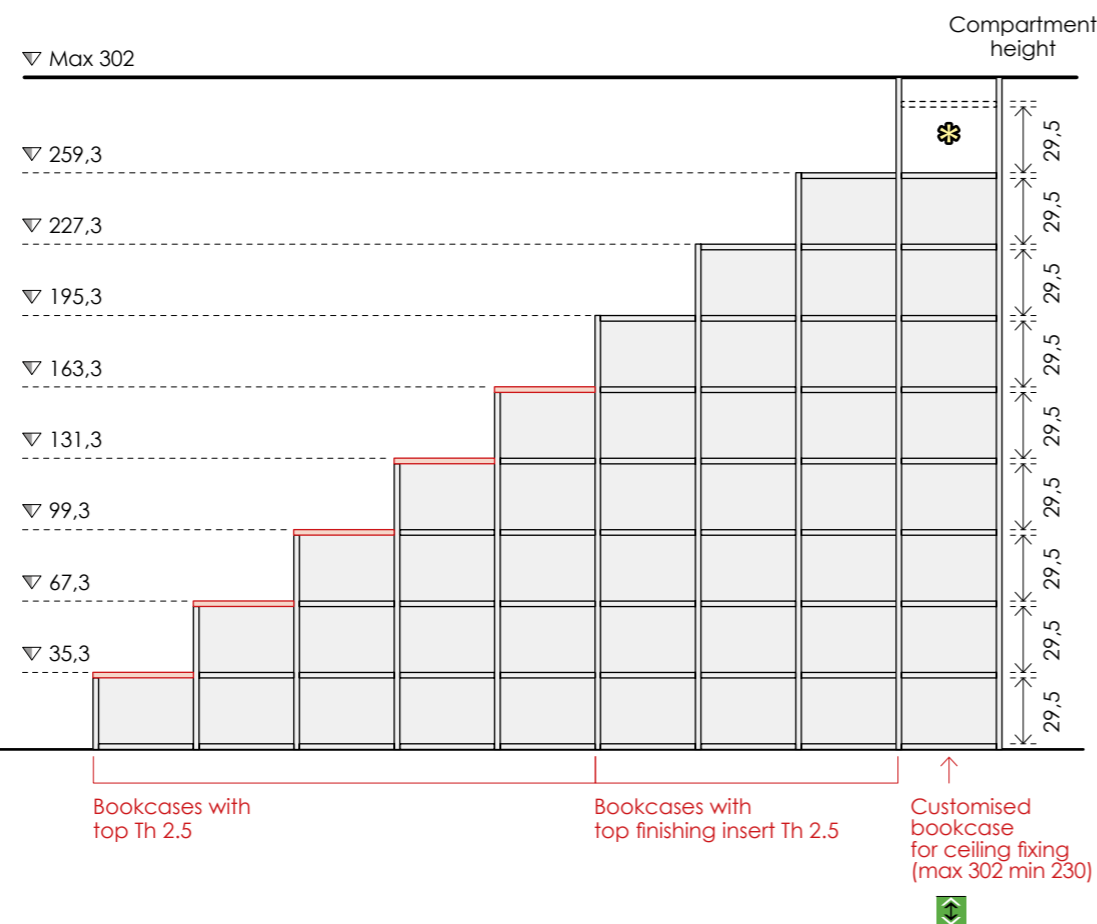

# Self standing bookcases Dpt 45.8 - Linear assembling

## SOME COMPOSITION EXAMPLES

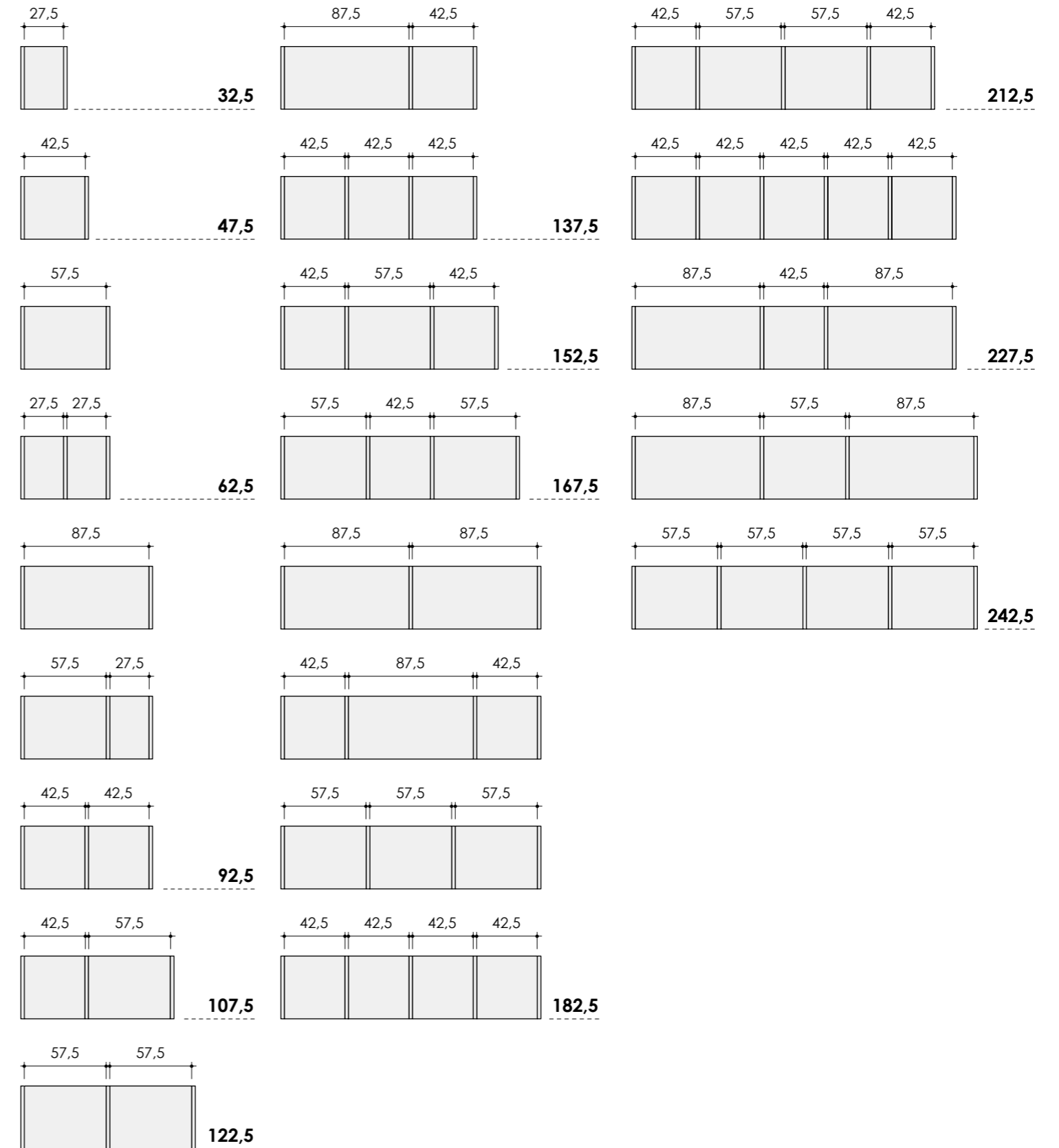

With TV compartment

The side panel is equipped with adjustable feet (top and bottom) for fixing between floor and ceiling which allow a maximum adjustment of 20 mm. **When ordering it is necessary to indicate the room height (floor-ceiling); the bookcase will be adjusted to size according to the distance detected.** We recommend that you check the room height in more than one point in order to find any excessive differences. With false ceilings you should check that in the event of inflection, the height difference does not exceed the 2 cm maximum adjustable range of the feet.



# Self standing bookcases Dpt 45.8

With back panel

\*  
To be completed with Top Th 2.5

W 30	Code	PK80.00H	PK80.01Q	PK80.02W	PK80.03C	PK80.04K	PK80.05R	PK80.06X	PK80.07D	PK80.65Y
W 45	Code	PK80.08L	PK80.09S	PK80.10P	PK80.11V	PK80.12B	PK80.13H	PK80.14Q	PK80.15W	PK80.66E
W 60	Code	PK80.16C	PK80.17K	PK80.18R	PK80.19X	PK80.20N	PK80.21A	PK80.22G	PK80.23P	PK80.67M
W 90	Code	PK80.24V	PK80.25B	PK80.26H	PK80.27Q	PK80.28W	PK80.29C	PK80.30Z	PK80.31F	PK80.68T

Customised bookcases for ceiling fixing.  
Ht room (Max 302 Min 230)

Movable shelves

W 27.5	Code	Melamine-coated Th 2,5		In transparent tempered glass Th 0,8		
		Dpt 43.3	Dpt 45.8	Dpt 42.3 with led	Dpt 41	Dpt 41 with led
W 27.5	Code	PK81.00N	PK81.01U	-	-	-
W 42.5	Code	PK81.02A	PK81.03G	PK81.04P	PK81.05V	PK81.06B
W 57.5	Code	PK81.07H	PK81.08Q	PK81.09W	PK81.10T	PK81.11Z
W 87.5	Code	PK81.12F	PK81.13N	PK81.14U	PK81.15A	PK81.16G

Two-sided see-through units

\*  
To be completed with Top Th 2.5

W 30	Code	PK80.32N	PK80.33U	PK80.34A	PK80.35G	PK80.36P	PK80.37V	PK80.38B	PK80.39H	PK80.71C
W 45	Code	PK80.40E	PK80.41M	PK80.42T	PK80.43Z	PK80.44F	PK80.45N	PK80.46U	PK80.47A	PK80.72K
W 60	Code	PK80.48G	PK80.49P	PK80.50L	PK80.51S	PK80.52Y	PK80.53E	PK80.54M	PK80.55T	PK80.73R
W 90	Code	PK80.56Z	PK80.57F	PK80.58N	PK80.59U	PK80.60R	PK80.61X	PK80.62D	PK80.63L	PK80.74X

Customised bookcases for ceiling fixing.  
Ht room (Max 302 Min 230)

led spotlights Ø 6.5  
We provide a power pack (with a surcharge) able to support from 1 to 6 spotlights.

Wireless switch  
For led lighting (usable for shelves and for spotlight).

Code	PL86.17N	PL86.18U
------	----------	----------

\*  
Top Dpt 45.8 - Th 2.5  
Max W 360 - Min W 30  
per linear metre

Code	PK81.20Y	PK81.21E	PK81.22M	PK81.23T
------	----------	----------	----------	----------

Backs Th 1.8

W 27.5	Code	PL85.64R	PL85.65X	PL85.66D	PL85.67L	PL85.68S	PL85.69Y	PL85.70V	PL85.71B
W 42.5	Code	PL85.72H	PL85.73Q	PL85.74W	PL85.75C	PL85.76K	PL85.77R	PL85.78X	PL85.79D
W 57.5	Code	PL85.80A	PL85.81G	PL85.82P	PL85.83V	PL85.84B	PL85.85H	PL85.86Q	PL85.87W
W 87.5	Code	PL85.88C	PL85.89K	PL85.90F	PL85.91N	PL85.92U	PL85.93A	PL85.94G	PL85.95P

Side panels on floor Dpt 45.8 - Th 2.5  
(Ht 0.8 foot not included)

Code	PK81.24Z	PK81.25F	PK81.26N	PK81.27U	PK81.28A	PK81.29G	PK81.30D	PK81.31L	PK81.32S
------	----------	----------	----------	----------	----------	----------	----------	----------	----------

Customised side panel for ceiling fixing  
Ht room (Max 302 Min 230)

☑ We provide a power pack (with a surcharge) able to support from 1 to 6 shelves W 45/60 or from 1 to 4 shelves W 90

- Components in **GROUP 2** colors
- Ⓐ For bookcases with back
- Ⓑ For see-through/two-sided bookcases

⬇ The side panel is equipped with adjustable feet (top and bottom) for fixing between floor and ceiling which allow a maximum adjustment of 20 mm. **When ordering it is necessary to indicate the room height (floor-ceiling); the bookcase will be adjusted to size according to the distance detected.** We recommend that you check the room height in more than one point in order to find any excessive differences. With false ceilings you should check that in the event of inflection, the height difference does not exceed the 2 cm maximum adjustable range of the feet.

- 👉 p. 732 Doors INFINITY
- 👉 p. 735 Drawers INFINITY
- 👉 p. 736 Sliding doors INFINITY

# Self standing bookcases Dpt 45.8 - Ht 195.3

With back panel

See-through

## W 30

Specify hinge R or L

Reference images →

<b>Code</b>	-	-	-	PK81.40K	PK81.41R	PK81.42X			-	-	-	PK81.61B	PK81.62H
ONE	matte	-	-	-	-	-			-	-	-	-	-
	glossy	-	-	-	-	-			-	-	-	-	-
CLUB		-	-	-	-	-			-	-	-	-	-
WINDOW		-	-	-	-	-			-	-	-	-	-

## W 45

Specify hinge R or L

<b>Code</b>	PK81.43D	PK81.44L	PK81.45S	PK81.46Y	PK81.47E	PK81.48M			PK81.63Q	PK81.64W	PK81.65C	PK81.66K	PK81.67R
ONE	matte												
	glossy												
CLUB													
WINDOW													

## W 60

Specify hinge R or L

<b>Code</b>	PK81.49T	PK81.50Q	PK81.51W	PK81.52C	PK81.53K	PK81.54R			PK81.68X	PK81.69D	PK81.70A	PK81.71G	PK81.72P
ONE	matte												
	glossy												
CLUB													
WINDOW													

## W 90

Reference images →

<b>Code</b>	PK81.55X	PK81.56D	PK81.57L	PK81.58S	PK81.59Y	PK81.60V			PK81.73V	PK81.74B	PK81.75H	PK81.76Q	PK81.77W
ONE	matte												
	glossy												
CLUB													
WINDOW													

### Movable shelves

Melamine-coated Th 2,5

Dpt 43.3

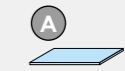

Dpt 45.8

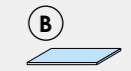

Dpt 42.3 with led



W 27.5	<b>Code</b>	PK81.00N	PK81.01U	-
W 42.5	<b>Code</b>	PK81.02A	PK81.03G	PK81.04P
W 57.5	<b>Code</b>	PK81.07H	PK81.08Q	PK81.09W
W 87.5	<b>Code</b>	PK81.12F	PK81.13N	PK81.14U

In transparent tempered glass Th 0,8

Dpt 41

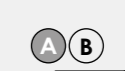

Dpt 41 with led

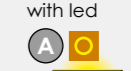

W 27.5	<b>Code</b>	-	-	
W 42.5	<b>Code</b>	PK81.05V	PK81.06B	
W 57.5	<b>Code</b>	PK81.10T	PK81.11Z	
W 87.5	<b>Code</b>	PK81.15A	PK81.16G	

led spotlights Ø 6.5  
We provide a power pack (with a surcharge) able to support from 1 to 6 spotlights. 12 volt 1.7 watt.



<b>Code</b>	PL86.17N
-------------	----------

Wireless switch  
For led lighting (usable for shelves and for spotlight).

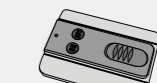

<b>Code</b>	PL86.18U
-------------	----------

### Side panel on floor Dpt 45.8 - Th 2.5

(Ht 0.8 foot not included)

Ht 194.5

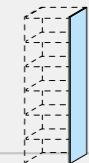

<b>Code</b>	PK81.29G
-------------	----------

- Components in **GROUP 2 colors**
- Components in **Types and colors FRONT**
- A For bookcases with back
- B For see-through bookcases

We provide a power pack (with a surcharge) able to support from 1 to 6 shelves W 45/60 or from 1 to 4 shelves W 90

p. 56 Knob and handle positions  
p. 732 Doors INFINITY  
p. 735 Drawers INFINITY

p. 736 Sliding doors INFINITY

# Self standing bookcases Dpt 45.8 - Ht 227.3

With back panel

See-through

## W 30

Specify hinge R or L

Reference images →

<b>Code</b>	-	-	-	PK81.80F	PK81.81N	PK81.82U			-	-	-	PK82.01Y	PK82.02E
ONE	matte	-	-	-	-	-			-	-	-	-	-
	glossy	-	-	-	-	-			-	-	-	-	-
CLUB		-	-	-	-	-			-	-	-	-	-
WINDOW		-	-	-	-	-			-	-	-	-	-

## W 45

Specify hinge R or L

<b>Code</b>	PK81.83A	PK81.84G	PK81.85P	PK81.86V	PK81.87B	PK81.88H			PK82.03M	PK82.04T	PK82.05Z	PK82.06F	PK82.07N
ONE	matte												
	glossy												
CLUB													
WINDOW													

## W 60

Specify hinge R or L

<b>Code</b>	PK81.89Q	PK81.90M	PK81.91T	PK81.92Z	PK81.93F	PK81.94N			PK82.08U	PK82.09A	PK82.10X	PK82.11D	PK82.12L
ONE	matte												
	glossy												
CLUB													
WINDOW													

## W 90

Reference images →

<b>Code</b>	PK81.95U	PK81.96A	PK81.97G	PK81.98P	PK81.99V	PK82.00S			PK82.13S	PK82.14Y	PK82.15E	PK82.16M	PK82.17T
ONE	matte												
	glossy												
CLUB													
WINDOW													

### Movable shelves

Melamine-coated Th 2,5

Dpt 43.3

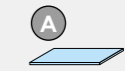

Dpt 45.8

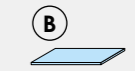

Dpt 42.3 with led



W 27.5	<b>Code</b>	PK81.00N	PK81.01U	-
W 42.5	<b>Code</b>	PK81.02A	PK81.03G	PK81.04P
W 57.5	<b>Code</b>	PK81.07H	PK81.08Q	PK81.09W
W 87.5	<b>Code</b>	PK81.12F	PK81.13N	PK81.14U

In transparent tempered glass Th 0,8

Dpt 41

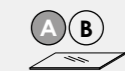

Dpt 41 with led



W 27.5	<b>Code</b>	-	-
W 42.5	<b>Code</b>	PK81.05V	PK81.06B
W 57.5	<b>Code</b>	PK81.10T	PK81.11Z
W 87.5	<b>Code</b>	PK81.15A	PK81.16G

led spotlights Ø 6.5  
We provide a power pack (with a surcharge) able to support from 1 to 6 spotlights. 12 volt 1.7 watt.



<b>Code</b>	PL86.17N
-------------	----------

Wireless switch  
For led lighting (usable for shelves and for spotlight).

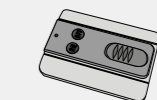

<b>Code</b>	PL86.18U
-------------	----------

### Side panel on floor Dpt 45.8 - Th 2.5

(Ht 0.8 foot not included)

Customised side panel for ceiling fixing  
Ht room (Max 302 Min 230)

Ht 226.5

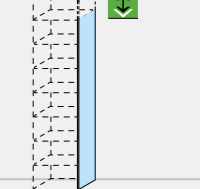
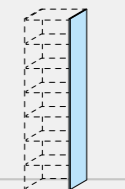

<b>Code</b>	PK81.30D	PK81.32S
-------------	----------	----------

- Components in **GROUP 2 colors**
- Components in **Types and colors FRONT**
- A For bookcases with back
- B For see-through bookcases

The side panel is equipped with adjustable feet (top and bottom) for fixing between floor and ceiling which allow a maximum adjustment of 20 mm. **When ordering it is necessary to indicate the room height (floor-ceiling); the bookcase will be adjusted to size according to the distance detected.** We recommend that you check the room height in more than one point in order to find any excessive differences. With false ceilings you should check that in the event of inflection, the height difference does not exceed the 2 cm maximum adjustable range of the feet.

We provide a power pack (with a surcharge) able to support from 1 to 6 shelves W 45/60 or from 1 to 4 shelves W 90

p. 56 Knob and handle positions  
p. 732 Doors INFINITY  
p. 735 Drawers INFINITY

p. 736 Sliding doors INFINITY

# Self standing bookcases Dpt 45.8 - Ht 259.3

With back panel

See-through

## W 30

Specify hinge R or L

Reference images →

<b>Code</b>	-	-	-	PK82.20C	PK82.21K	PK82.22R				-	-	-	PK82.41V	PK82.42B
ONE	matte	-	-	-	-	-				-	-	-	-	-
	glossy	-	-	-	-	-				-	-	-	-	-
CLUB		-	-	-	-	-				-	-	-	-	-
WINDOW		-	-	-	-	-				-	-	-	-	-

## W 45

Specify hinge R or L

<b>Code</b>	PK82.23X	PK82.24D	PK82.25L	PK82.26S	PK82.27Y	PK82.28E					PK82.43H	PK82.44Q	PK82.45W	PK82.46C	PK82.47K
ONE	matte														
	glossy														
CLUB															
WINDOW															

## W 60

Specify hinge R or L

<b>Code</b>	PK82.29M	PK82.30H	PK82.31Q	PK82.32W	PK82.33C	PK82.34K					PK82.48R	PK82.49X	PK82.50U	PK82.51A	PK82.52G
ONE	matte														
	glossy														
CLUB															
WINDOW															

## W 90

Reference images →

<b>Code</b>	PK82.35R	PK82.36X	PK82.37D	PK82.38L	PK82.39S	PK82.40P					PK82.53P	PK82.54V	PK82.55B	PK82.56H	PK82.57Q
ONE	matte														
	glossy														
CLUB															
WINDOW															

### Movable shelves

Melamine-coated Th 2,5

Dpt 43.3

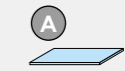

Dpt 45.8

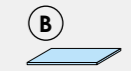

Dpt 42.3 with led



W 27.5	<b>Code</b>	PK81.00N	PK81.01U	-
W 42.5	<b>Code</b>	PK81.02A	PK81.03G	PK81.04P
W 57.5	<b>Code</b>	PK81.07H	PK81.08Q	PK81.09W
W 87.5	<b>Code</b>	PK81.12F	PK81.13N	PK81.14U

In transparent tempered glass Th 0,8

Dpt 41

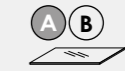

Dpt 41 with led



W 27.5	<b>Code</b>	-	-
W 42.5	<b>Code</b>	PK81.05V	PK81.06B
W 57.5	<b>Code</b>	PK81.10T	PK81.11Z
W 87.5	<b>Code</b>	PK81.15A	PK81.16G

led spotlights Ø 6.5  
We provide a power pack (with a surcharge) able to support from 1 to 6 spotlights. 12 volt 1.7 watt.



<b>Code</b>	PL86.17N
-------------	----------

Wireless switch  
For led lighting (usable for shelves and for spotlight).

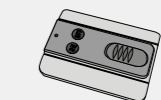

<b>Code</b>	PL86.18U
-------------	----------

### Side panel on floor Dpt 45.8 - Th 2.5

(Ht 0.8 foot not included)

Customised side panel for ceiling fixing  
Ht room (Max 302 Min 230)

Ht 258.5

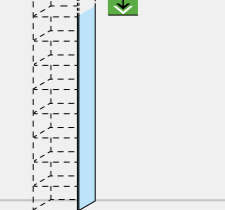
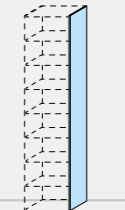

<b>Code</b>	PK81.31L	PK81.32S
-------------	----------	----------

- Components in **GROUP 2 colors**
- Components in **Types and colors FRONT**
- A For bookcases with back
- B For see-through bookcases

The side panel is equipped with adjustable feet (top and bottom) for fixing between floor and ceiling which allow a maximum adjustment of 20 mm. **When ordering it is necessary to indicate the room height (floor-ceiling); the bookcase will be adjusted to size according to the distance detected.** We recommend that you check the room height in more than one point in order to find any excessive differences. With false ceilings you should check that in the event of inflection, the height difference does not exceed the 2 cm maximum adjustable range of the feet.

We provide a power pack (with a surcharge) able to support from 1 to 6 shelves W 45/60 or from 1 to 4 shelves W 90

p. 56 Knob and handle positions  
p. 732 Doors INFINITY  
p. 735 Drawers INFINITY

p. 736 Sliding doors INFINITY

## Self standing corner bookcases Dpt 45.8 - Full corner

With back panel

<b>Code</b>	<b>PK82.60Z</b>	<b>PK82.61F</b>	<b>PK82.62N</b>	<b>PK82.63U</b>		<b>PK82.70E</b>

Melamine-coated  
Dpt 43.3  
Th 2.5

See-through

<b>Code</b>	<b>PK82.65G</b>	<b>PK82.66P</b>	<b>PK82.67V</b>	<b>PK82.68B</b>		<b>PK82.71M</b>

Melamine-coated  
Dpt 45.8  
Th 2.5

Side panels on floor  
Dpt 45.8 - Th 2.5

(H 0.8 foot not included)

<b>Code</b>	<b>PK81.29G</b>	<b>PK81.30D</b>	<b>PK81.31L</b>	<b>PK81.32S</b>	

Technical information

- Available in open version or with pair of doors. Handle is always provided on the Right door.
- Size proportion changes are not available.

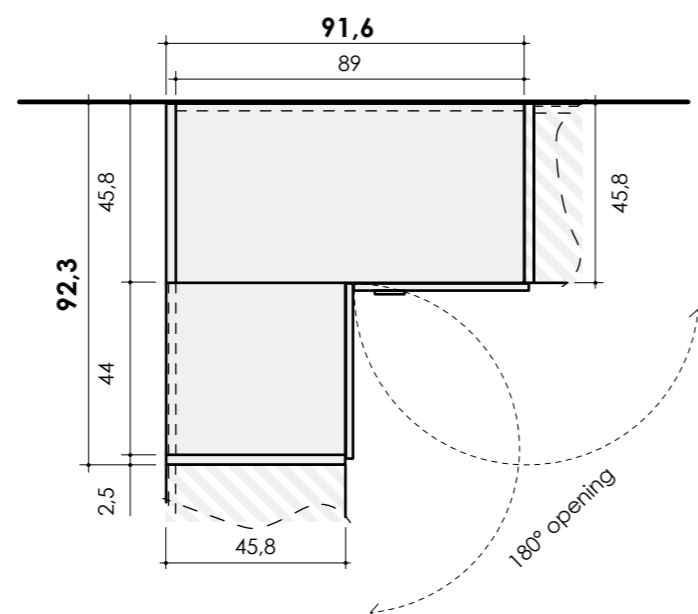

Components in GROUP 2 colors

The side panel is equipped with adjustable feet (top and bottom) for fixing between floor and ceiling which allow a maximum adjustment of 20 mm. **When ordering it is necessary to indicate the room height (floor-ceiling); the bookcase will be adjusted to size according to the distance detected.** We recommend that you check the room height in more than one point in order to find any excessive differences. With false ceilings you should check that in the event of inflection, the height difference does not exceed the 2 cm maximum adjustable range of the feet.

## Self standing end-bookcases Dpt 45.8

<b>Code</b>	<b>PK82.75N</b>	<b>PK82.76U</b>	<b>PK82.77A</b>	<b>PK82.78G</b>		<b>PK82.79P</b>

Melamine-coated  
Dpt 43.3  
Th 2.5

Technical information

- Available only in open version.

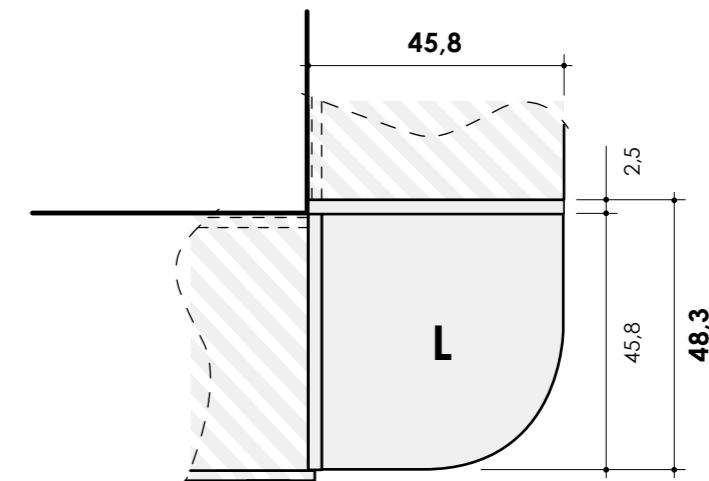
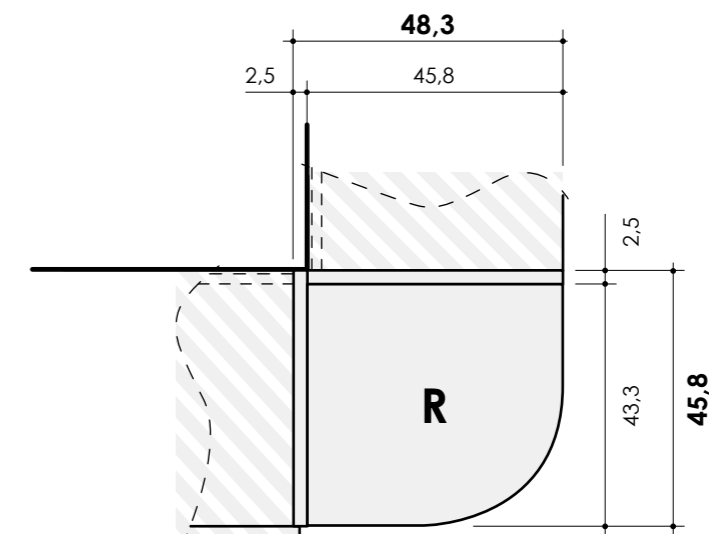
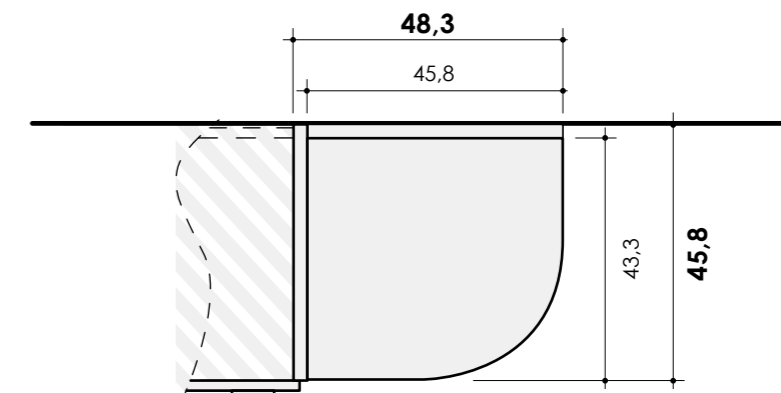



# Self standing bookcases Dpt 45.8 - For passage

With back panel

**W 90**

Specify hinge R or L

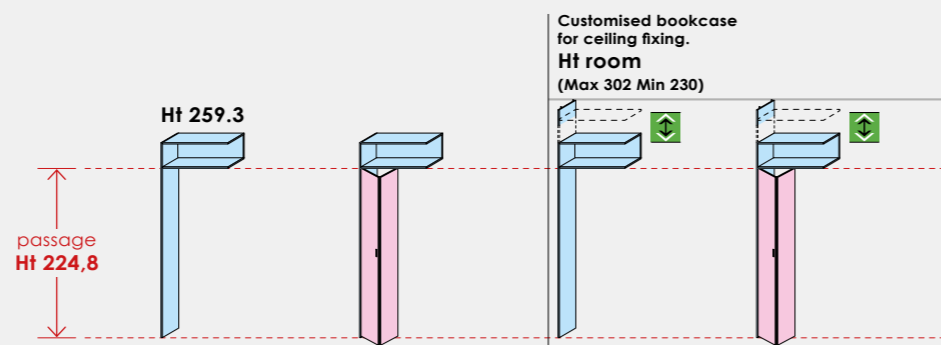

Code	PK80.64S	PK80.76L	PK80.69Z	PK80.77S
ONE	matte			
	glossy			

Two-sided see-through units

**W 90**

Specify hinge R or L

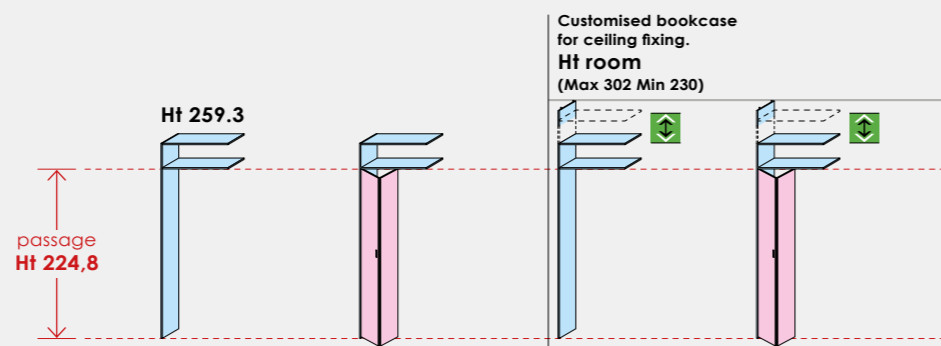

Code	PK80.70W	PK80.78Y	PK80.75D	PK80.79E
ONE	matte			
	glossy			

**Movable shelves**

Melamine-coated  
Th 2,5

Dpt 43.3



Dpt 45.8



Dpt 42.3  
with led



In transparent tempered glass  
Th 0,8

Dpt 41



Dpt 41  
with led



**W 87.5**

Code	PK81.12F	PK81.13N	PK81.14U	PK81.15A	PK81.16G

**led spotlights Ø 6.5**

We provide a power pack (with a surcharge) able to support from 1 to 6 spotlights. 12 volt 1.7 watt.



**Wireless switch**

For led lighting (usable for shelves and for spotlight).

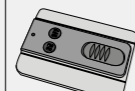

Code	PL86.17N	PL86.18U

## Technical information

- The over-door bookshelves (without bottom panel) must be between two wardrobes with bottom panel, one on the right, and one on the left.
- In the presence of folding doors specify whether the hinge is R or L. There is only one handle positioned on the door hinged to the side.
- Track for folding door in Aluminium colour.

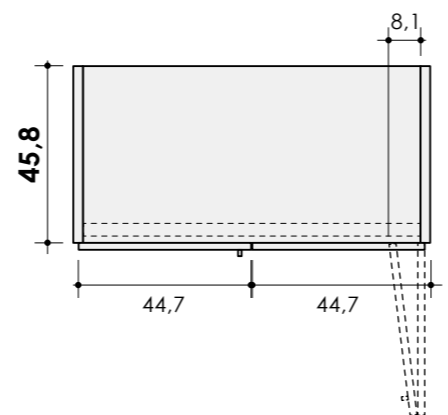

- Components in **GROUP 2 colors**
- Components in **Types and colors FRONT**
- Ⓐ For bookcases with back
- Ⓑ For see-through/two-sided bookcases

⬆️ The side panel is equipped with adjustable feet (top and bottom) for fixing between floor and ceiling which allow a maximum adjustment of 20 mm. **When ordering it is necessary to indicate the room height (floor-ceiling); the bookcase will be adjusted to size according to the distance detected.** We recommend that you check the room height in more than one point in order to find any excessive differences. With false ceilings you should check that in the event of inflection, the height difference does not exceed the 2 cm maximum adjustable range of the feet.

■ We provide a power pack (with a surcharge) able to support from 1 to 6 shelves W 45/60 or from 1 to 4 shelves W 90



# Self standing bookcases Dpt 45.8 - With peninsula

**Ht 195.3**

Specify hinge  
R or L

Code	PK82.80L	PK82.81S	PK82.82Y	PK82.83E	PK81.29G	
------	----------	----------	----------	----------	----------	--

**Ht 227.3**

Specify hinge  
R or L

Code	PK82.84M	PK82.85T	PK82.86Z	PK82.87F	PK81.30D	PK81.32S
------	----------	----------	----------	----------	----------	----------

**Ht 259.3**

Specify hinge  
R or L

Code	PK82.88N	PK82.89U	PK82.90R	PK82.91X	PK81.31L	PK81.32S
------	----------	----------	----------	----------	----------	----------

**Backs  
Th 1.8**

**W 45**

	Ht 29.5	Ht 61.5	Ht 93.5	Ht 125.5	Ht 189.5	Ht 221.5	Ht 253.5
Code	PL85.72H	PL85.73Q	PL85.74W	PL85.75C	PL85.77R	PL85.78X	PL85.79D

With back panel

See-through

Side panels on floor  
Dpt 45.8 - Th 2.5  
(Ht 0.8 foot not included)

## Supports for peninsula tops

Code	Metal leg	POP leg	TRIS leg	SLIM leg	BIT leg	HEY leg
P28.86N	Ht 75,1 Ø 8 Base Ø 23	W 20 Ht 75,1 Dpt 43,3	W 11,8 Ht 75,1	W 7 Ht 75,1 Th 2	W 46 Ht 75,1	W 5 Ht 75,1 Dpt 43,5

Desk tops  
H from the floor 77.8

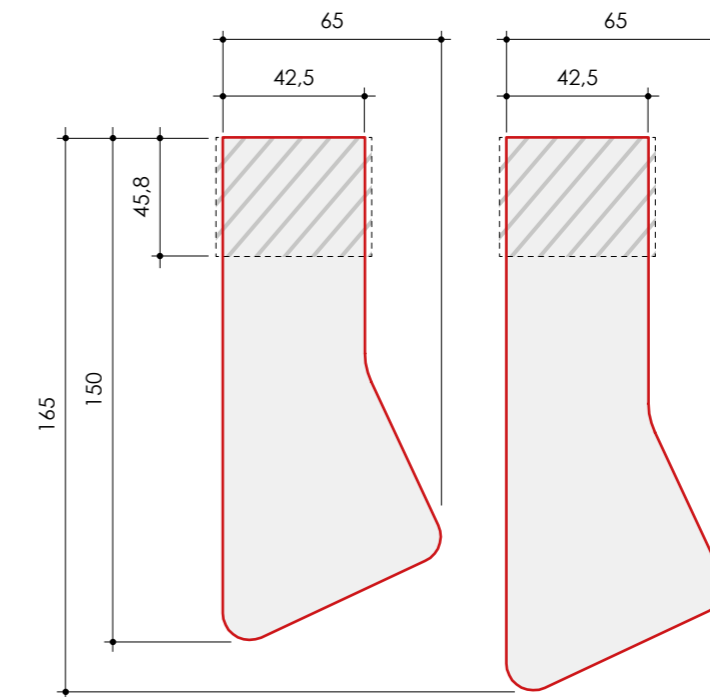

**Movable shelves**

**W 42.5**

Code	Melamine-coated Th 2,5	In transparent tempered glass Th 0,8	led spotlights Ø 6.5 We provide a power pack (with a surcharge) able to support from 1 to 6 spotlights. 12 volt 1.7 watt.
PK81.02A	Dpt 43.3 A	Dpt 41 A B	PL86.17N
PK81.03G	Dpt 45.8 B	Dpt 41 with led A B	PL86.18U
PK81.04P	Dpt 42.3 with led A B	Dpt 41 with led A B	
PK81.05V			
PK81.06B			

**OPTIONAL:** C - Extra colors for Metal leg disc  
p. 409

p. 732 Doors INFINITY  
p. 735 Drawers INFINITY  
p. 736 Sliding doors INFINITY

- Components in **GROUP 2 colors**
  - Completed by selecting one of the **Supports for peninsula tops**
  - A For bookcases with back
  - B For see-through bookcases
  - Components available with contrasting edging.
- 

The side panel is equipped with adjustable feet (top and bottom) for fixing between floor and ceiling which allow a maximum adjustment of 20 mm. **When ordering it is necessary to indicate the room height (floor-ceiling); the bookcase will be adjusted to size according to the distance detected.** We recommend that you check the room height in more than one point in order to find any excessive differences. With false ceilings you should check that in the event of inflection, the height difference does not exceed the 2 cm maximum adjustable range of the feet.

We provide a power pack (with a surcharge) able to support from 1 to 6 shelves W 45/60 or from 1 to 4 shelves W 90

# Self standing bookcases Dpt 45.8 - With TV compartment

With back panel

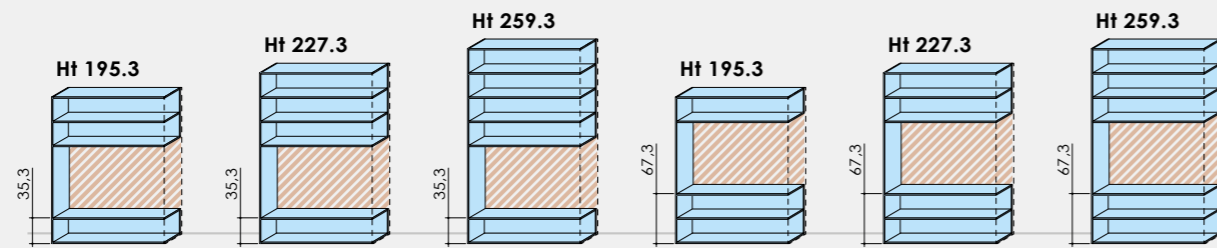

W 120	Code	PK83.00W	PK83.01C	PK83.02K	PK83.03R	PK83.04X	PK83.05D
W 150	Code	PK83.06L	PK83.07S	PK83.08Y	PK83.09E	PK83.10B	PK83.11H
W 180	Code	PK83.12Q	PK83.13W	PK83.14C	PK83.15K	PK83.16R	PK83.17X

See-through

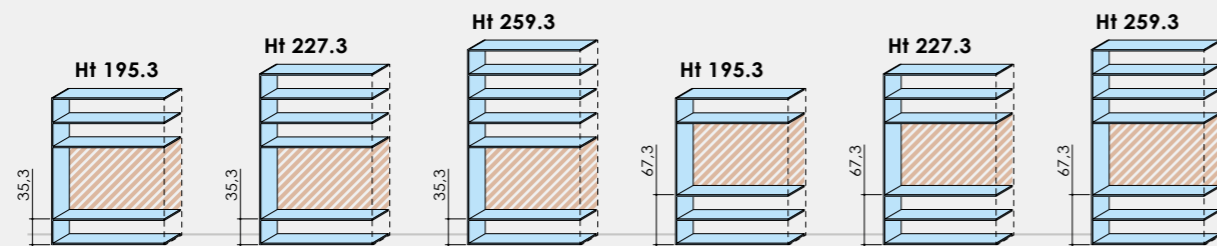

W 120	Code	PK83.20G	PK83.21P	PK83.22V	PK83.23B	PK83.24H	PK83.25Q
W 150	Code	PK83.26W	PK83.27C	PK83.28K	PK83.29R	PK83.30N	PK83.31U
W 180	Code	PK83.32A	PK83.33G	PK83.34P	PK83.35V	PK83.36B	PK83.37H

## TV compartments with lighting system

Always order one for every composition.

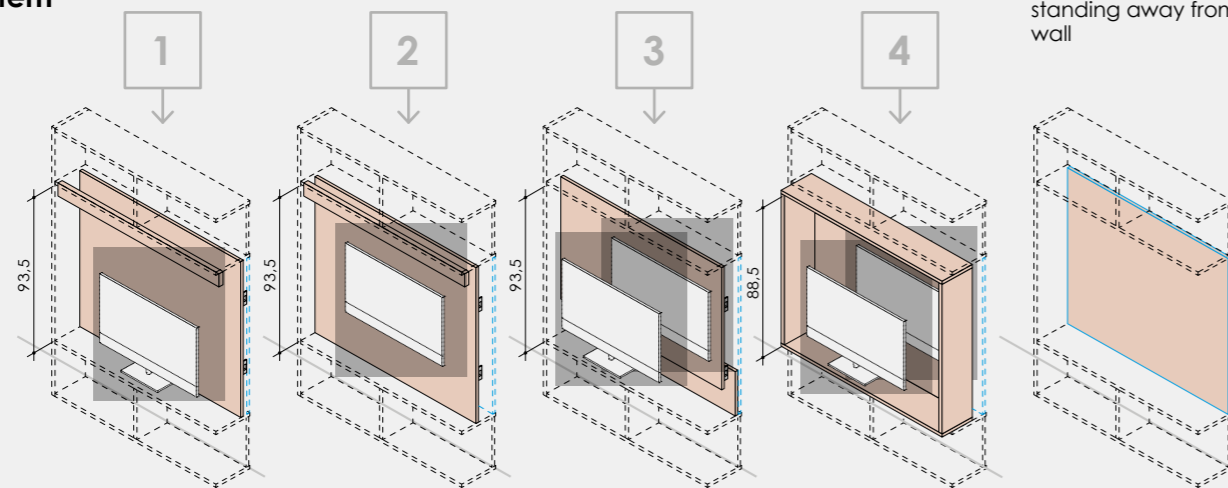

Finishing back panel for TV compartments standing away from wall

W 120	Code	PL93.60K	PL93.61R	PL93.62X	PL93.63D	PL93.64L
W 150	Code	PL93.65S	PL93.66Y	PL93.67E	PL93.68M	PL93.69T
W 180	Code	PL93.70Q	PL93.71W	PL93.72C	PL93.73K	PL93.74R

- Components in **GROUP 2 colors**
- Components in **GROUP 3 colors**
- A For bookcases with back
- B For see-through bookcases

▶ The side panel is equipped with adjustable feet (top and bottom) for fixing between floor and ceiling which allow a maximum adjustment of 20 mm. **When ordering it is necessary to indicate the room height (floor-ceiling); the bookcase will be adjusted to size according to the distance detected.** We recommend that you check the room height in more than one point in order to find any excessive differences. With false ceilings you should check that in the event of inflection, the height difference does not exceed the 2 cm maximum adjustable range of the feet.

## Backs Th 1.8

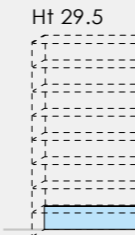

W 117.5	Code	PL87.50T
W 147.5	Code	PL87.51Z
W 177.5	Code	PL87.52F

## Side panels on floor Dpt 45.8 - Th 2.5 (H 0.8 foot not included)

Customised side panel for ceiling fixing  
Ht room (Max 302 Min 230)

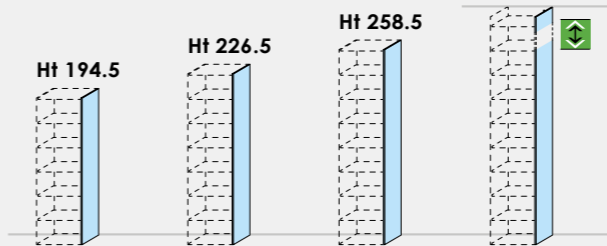

Code	PK81.29G	PK81.30D	PK81.31L	PK81.32S
------	----------	----------	----------	----------

## Dividing panel positioning instructions

The grid in each horizontal section is divided every 15 cm. Dividing panels must be mounted following the instruction below:  
**SIDE compartments L Max 73.8 - Min 28.8 cm.**  
**MIDDLE compartments L Max 75 - Min 30 cm.**  
The position of **load-bearing** dividing panels establishes the holes on the above and below shelves.

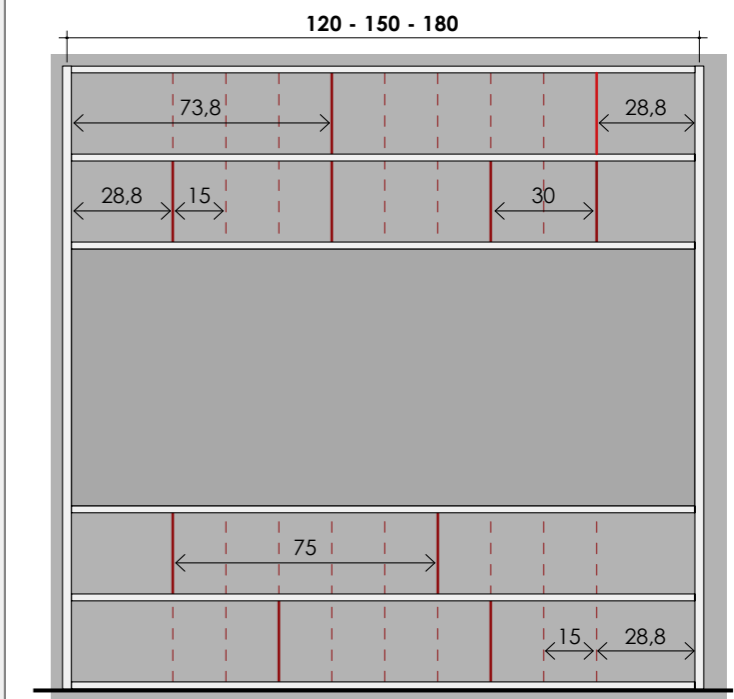

## Melamine-faced dividing panels Ht 29.5 - Th 2.5

Load-Bearing

Can be equipped with standard doors and drawers.

SHARE Dpt 43.3	SHARE Dpt 45.8	ELLE Dpt 43.3 Th 2.5	SEPARÉ Dpt 43.3 Th 2.5
<span style="border: 1px solid black; border-radius: 50%; padding: 2px;">A</span>	<span style="border: 1px solid black; border-radius: 50%; padding: 2px;">B</span>	<span style="border: 1px solid black; border-radius: 50%; padding: 2px;">B</span>	<span style="border: 1px solid black; border-radius: 50%; padding: 2px;">B</span>
<b>W</b>	<b>Code</b>	<b>W</b>	<b>Code</b>
30	PK83.42F	32.5	PK83.47P
45	PK83.43N	47.5	PK83.48V
60	PK83.44U	62.5	PK83.49B
75	PK83.45A	77.5	PK83.50Y
90	PK83.46G	92.5	PK83.51E

## Movable shelves

Melamine-coated Th 2.5	In transparent tempered glass Th 0.8	led spotlights Ø 6.5
Dpt 43.3 <span style="border: 1px solid black; border-radius: 50%; padding: 2px;">A</span>	Dpt 45.8 <span style="border: 1px solid black; border-radius: 50%; padding: 2px;">B</span>	Dpt 42.3 with led <span style="border: 1px solid black; border-radius: 50%; padding: 2px;">A</span>
		Dpt 41 with led <span style="border: 1px solid black; border-radius: 50%; padding: 2px;">A</span>

W 27.5	Code	PK81.00N	PK81.01U	-	-	-	Code	PL86.17N
W 42.5	Code	PK81.02A	PK81.03G	PK81.04P	PK81.05V	PK81.06B		
W 57.5	Code	PK81.07H	PK81.08Q	PK81.09W	PK81.10T	PK81.11Z		
W 87.5	Code	PK81.12F	PK81.13N	PK81.14U	PK81.15A	PK81.16G		

▶ We provide a power pack (with a surcharge) able to support from 1 to 6 shelves W 45/60 or from 1 to 4 shelves W 90

**Wireless switch**  
For led lighting (usable for shelves and for spotlight).

Code **PL86.18U**

GROUP 1 colors	Rovere Dorian <b>RD5T</b>	Rovere white <b>RW3Q</b>	Noce naturale <b>NN7H</b>	Eucalipto <b>CL1X</b>	Domy <b>DM7P</b>	Bianco UV <b>BU3Q</b>
	Ciliegio bianco <b>CB6K</b>	Malta <b>ML7H</b>	Feltro <b>FL8X</b>	Cemento Masdar <b>CM3Q</b>	Blu indaco <b>BI4B</b>	
	Noce <b>NC4B</b>	Desert <b>DS9L</b>	Canapa <b>CN1X</b>	Moka <b>MK6B</b>	Cipria <b>CP4J</b>	
	Bianco opaco <b>BI7A</b>	Grigio Dorian <b>GL4R</b>	Basalto <b>BS5T</b>	Grigio titanio <b>GZ8T</b>	Rosa bubble <b>RB7Y</b>	
	Agave <b>GV7A</b>	Verde Alpi <b>VA5T</b>	Cadaques <b>CQ3Q</b>	Giallo zafferano <b>GZ8A</b>		
	Blu opale <b>BO7H</b>			Corallo <b>CR5T</b>		

Types and colors FRONT	ONE	<table border="1"> <tr> <td>Rovere white <b>RW3Q</b></td> <td>Rovere Dorian <b>RD5T</b></td> <td>Ciliegio bianco <b>CB6K</b></td> <td>Noce naturale <b>NN7H</b></td> <td>Noce <b>NC4B</b></td> <td>Eucalipto <b>CL1X</b></td> <td>Malta <b>ML7H</b></td> </tr> <tr> <td>Feltro <b>FL8X</b></td> <td>Cemento Masdar <b>CM3Q</b></td> <td>Bianco opaco <b>BI7A</b></td> <td>Desert <b>DS9L</b></td> <td>Canapa <b>CN1X</b></td> <td>Moka <b>MK6B</b></td> <td>Grigio Dorian <b>GL4R</b></td> </tr> <tr> <td>Basalto <b>BS5T</b></td> <td>Grigio titanio <b>GZ8T</b></td> <td>Domy <b>DM7P</b></td> <td>Agave <b>GV7A</b></td> <td>Verde Alpi <b>VA5T</b></td> <td>Cadaques <b>CQ3Q</b></td> <td>Blu indaco <b>BI4B</b></td> </tr> <tr> <td>Blu opale <b>BO7H</b></td> <td>Cipria <b>CP4J</b></td> <td>Rosa bubble <b>RB7Y</b></td> <td>Giallo zafferano <b>GZ8A</b></td> <td>Corallo <b>CR5T</b></td> <td></td> <td></td> </tr> </table>	Rovere white <b>RW3Q</b>	Rovere Dorian <b>RD5T</b>	Ciliegio bianco <b>CB6K</b>	Noce naturale <b>NN7H</b>	Noce <b>NC4B</b>	Eucalipto <b>CL1X</b>	Malta <b>ML7H</b>	Feltro <b>FL8X</b>	Cemento Masdar <b>CM3Q</b>	Bianco opaco <b>BI7A</b>	Desert <b>DS9L</b>	Canapa <b>CN1X</b>	Moka <b>MK6B</b>	Grigio Dorian <b>GL4R</b>	Basalto <b>BS5T</b>	Grigio titanio <b>GZ8T</b>	Domy <b>DM7P</b>	Agave <b>GV7A</b>	Verde Alpi <b>VA5T</b>	Cadaques <b>CQ3Q</b>	Blu indaco <b>BI4B</b>	Blu opale <b>BO7H</b>	Cipria <b>CP4J</b>	Rosa bubble <b>RB7Y</b>	Giallo zafferano <b>GZ8A</b>	Corallo <b>CR5T</b>																							
		Rovere white <b>RW3Q</b>	Rovere Dorian <b>RD5T</b>	Ciliegio bianco <b>CB6K</b>	Noce naturale <b>NN7H</b>	Noce <b>NC4B</b>	Eucalipto <b>CL1X</b>	Malta <b>ML7H</b>																																											
		Feltro <b>FL8X</b>	Cemento Masdar <b>CM3Q</b>	Bianco opaco <b>BI7A</b>	Desert <b>DS9L</b>	Canapa <b>CN1X</b>	Moka <b>MK6B</b>	Grigio Dorian <b>GL4R</b>																																											
Basalto <b>BS5T</b>	Grigio titanio <b>GZ8T</b>	Domy <b>DM7P</b>	Agave <b>GV7A</b>	Verde Alpi <b>VA5T</b>	Cadaques <b>CQ3Q</b>	Blu indaco <b>BI4B</b>																																													
Blu opale <b>BO7H</b>	Cipria <b>CP4J</b>	Rosa bubble <b>RB7Y</b>	Giallo zafferano <b>GZ8A</b>	Corallo <b>CR5T</b>																																															
matte																																																			
glossy	Bianco UV <b>BU3Q</b>																																																		
CLUB	<table border="1"> <tr> <td>Rovere white <b>RW3Q</b></td> <td>Rovere Dorian <b>RD5T</b></td> <td>Ciliegio bianco <b>CB6K</b></td> <td>Noce naturale <b>NN7H</b></td> <td>Noce <b>NC4B</b></td> <td>Eucalipto <b>CL1X</b></td> <td>Malta <b>ML7H</b></td> </tr> <tr> <td>Feltro <b>FL8X</b></td> <td>Cemento Masdar <b>CM3Q</b></td> <td>Bianco opaco <b>BI7A</b></td> <td>Desert <b>DS9L</b></td> <td>Canapa <b>CN1X</b></td> <td>Moka <b>MK6B</b></td> <td>Grigio Dorian <b>GL4R</b></td> </tr> <tr> <td>Basalto <b>BS5T</b></td> <td>Grigio titanio <b>GZ8T</b></td> <td>Domy <b>DM7P</b></td> <td>Agave <b>GV7A</b></td> <td>Verde Alpi <b>VA5T</b></td> <td>Cadaques <b>CQ3Q</b></td> <td>Blu indaco <b>BI4B</b></td> </tr> <tr> <td>Blu opale <b>BO7H</b></td> <td>Cipria <b>CP4J</b></td> <td>Rosa bubble <b>RB7Y</b></td> <td>Giallo zafferano <b>GZ8A</b></td> <td>Corallo <b>CR5T</b></td> <td></td> <td></td> </tr> </table>	Rovere white <b>RW3Q</b>	Rovere Dorian <b>RD5T</b>	Ciliegio bianco <b>CB6K</b>	Noce naturale <b>NN7H</b>	Noce <b>NC4B</b>	Eucalipto <b>CL1X</b>	Malta <b>ML7H</b>	Feltro <b>FL8X</b>	Cemento Masdar <b>CM3Q</b>	Bianco opaco <b>BI7A</b>	Desert <b>DS9L</b>	Canapa <b>CN1X</b>	Moka <b>MK6B</b>	Grigio Dorian <b>GL4R</b>	Basalto <b>BS5T</b>	Grigio titanio <b>GZ8T</b>	Domy <b>DM7P</b>	Agave <b>GV7A</b>	Verde Alpi <b>VA5T</b>	Cadaques <b>CQ3Q</b>	Blu indaco <b>BI4B</b>	Blu opale <b>BO7H</b>	Cipria <b>CP4J</b>	Rosa bubble <b>RB7Y</b>	Giallo zafferano <b>GZ8A</b>	Corallo <b>CR5T</b>			<p>Specify the color of the CLUB handle</p> <table border="1"> <tr> <td>Bianco opaco <b>BI7A</b></td> <td>Desert <b>DS9L</b></td> <td>Canapa <b>CN1X</b></td> <td>Moka <b>MK6B</b></td> <td>Grigio Dorian <b>GL4R</b></td> <td>Basalto <b>BS5T</b></td> <td>Grigio titanio <b>GZ8T</b></td> </tr> <tr> <td>Domy <b>DM7P</b></td> <td>Agave <b>GV7A</b></td> <td>Verde Alpi <b>VA5T</b></td> <td>Cadaques <b>CQ3Q</b></td> <td>Blu indaco <b>BI4B</b></td> <td>Blu opale <b>BO7H</b></td> <td>Cipria <b>CP4J</b></td> </tr> <tr> <td>Rosa bubble <b>RB7Y</b></td> <td>Giallo zafferano <b>GZ8A</b></td> <td>Corallo <b>CR5T</b></td> <td></td> <td></td> <td></td> <td></td> </tr> </table>	Bianco opaco <b>BI7A</b>	Desert <b>DS9L</b>	Canapa <b>CN1X</b>	Moka <b>MK6B</b>	Grigio Dorian <b>GL4R</b>	Basalto <b>BS5T</b>	Grigio titanio <b>GZ8T</b>	Domy <b>DM7P</b>	Agave <b>GV7A</b>	Verde Alpi <b>VA5T</b>	Cadaques <b>CQ3Q</b>	Blu indaco <b>BI4B</b>	Blu opale <b>BO7H</b>	Cipria <b>CP4J</b>	Rosa bubble <b>RB7Y</b>	Giallo zafferano <b>GZ8A</b>	Corallo <b>CR5T</b>				
		Rovere white <b>RW3Q</b>	Rovere Dorian <b>RD5T</b>	Ciliegio bianco <b>CB6K</b>	Noce naturale <b>NN7H</b>	Noce <b>NC4B</b>	Eucalipto <b>CL1X</b>	Malta <b>ML7H</b>																																											
		Feltro <b>FL8X</b>	Cemento Masdar <b>CM3Q</b>	Bianco opaco <b>BI7A</b>	Desert <b>DS9L</b>	Canapa <b>CN1X</b>	Moka <b>MK6B</b>	Grigio Dorian <b>GL4R</b>																																											
Basalto <b>BS5T</b>	Grigio titanio <b>GZ8T</b>	Domy <b>DM7P</b>	Agave <b>GV7A</b>	Verde Alpi <b>VA5T</b>	Cadaques <b>CQ3Q</b>	Blu indaco <b>BI4B</b>																																													
Blu opale <b>BO7H</b>	Cipria <b>CP4J</b>	Rosa bubble <b>RB7Y</b>	Giallo zafferano <b>GZ8A</b>	Corallo <b>CR5T</b>																																															
Bianco opaco <b>BI7A</b>	Desert <b>DS9L</b>	Canapa <b>CN1X</b>	Moka <b>MK6B</b>	Grigio Dorian <b>GL4R</b>	Basalto <b>BS5T</b>	Grigio titanio <b>GZ8T</b>																																													
Domy <b>DM7P</b>	Agave <b>GV7A</b>	Verde Alpi <b>VA5T</b>	Cadaques <b>CQ3Q</b>	Blu indaco <b>BI4B</b>	Blu opale <b>BO7H</b>	Cipria <b>CP4J</b>																																													
Rosa bubble <b>RB7Y</b>	Giallo zafferano <b>GZ8A</b>	Corallo <b>CR5T</b>																																																	
WINDOW	<table border="1"> <tr> <td>Trasparente <b>TR9M</b></td> <td>Trasparente fumé <b>FT8P</b></td> <td>Stop-sol <b>ST6P</b></td> <td>Specchio <b>SP7L</b></td> </tr> </table> <p>Specify the color of the aluminum frame</p> <table border="1"> <tr> <td>Alluminio <b>AL1A</b></td> <td>Titan grey <b>TG7H</b></td> </tr> </table>	Trasparente <b>TR9M</b>	Trasparente fumé <b>FT8P</b>	Stop-sol <b>ST6P</b>	Specchio <b>SP7L</b>	Alluminio <b>AL1A</b>	Titan grey <b>TG7H</b>																																												
Trasparente <b>TR9M</b>	Trasparente fumé <b>FT8P</b>	Stop-sol <b>ST6P</b>	Specchio <b>SP7L</b>																																																
Alluminio <b>AL1A</b>	Titan grey <b>TG7H</b>																																																		

**INFINITY bookcases - Suspended**

Suspended Bookcases Dpt 33.3 - Dimensions	810
Suspended Bookcases Dpt 33.3 - Linear assembling	811
Suspended Bookcases Dpt 33.3 - For top	812
Suspended Bookcases Dpt 33.3 - With top finishing insert	814
Suspended Bookcases Dpt 33.3 - EASY	816
Suspended Bookcases maxi Dpt 33.3 - For top	818
Suspended Bookcases maxi Dpt 33.3 - With top finishing insert	819
Suspended Bookcases maxi Dpt 33.3 - Dividing panels	820
Suspended Bookcases Dpt 33.3 - Semi-suspended	822
Suspended Bookcases Dpt 33.3 - Overhead units	826
Suspended corner Bookcases Dpt 33.3 - Full corner	827
Suspended Bookcases Dpt 33.3 - For top with TV compartment	828
Suspended Bookcases Dpt 33.3 - With TV compartment and top finishing insert	830
DOCKS modular units for bookcases INFINITY Dpt 33.3	832
MAGIC modular units suspended for bookcases INFINITY Dpt 33.3	834
GOLF product data sheet	838
General conditions of sale	840

# Suspended Bookcases Dpt 33.3 - Dimensions

## WIDTH AND DEPTH

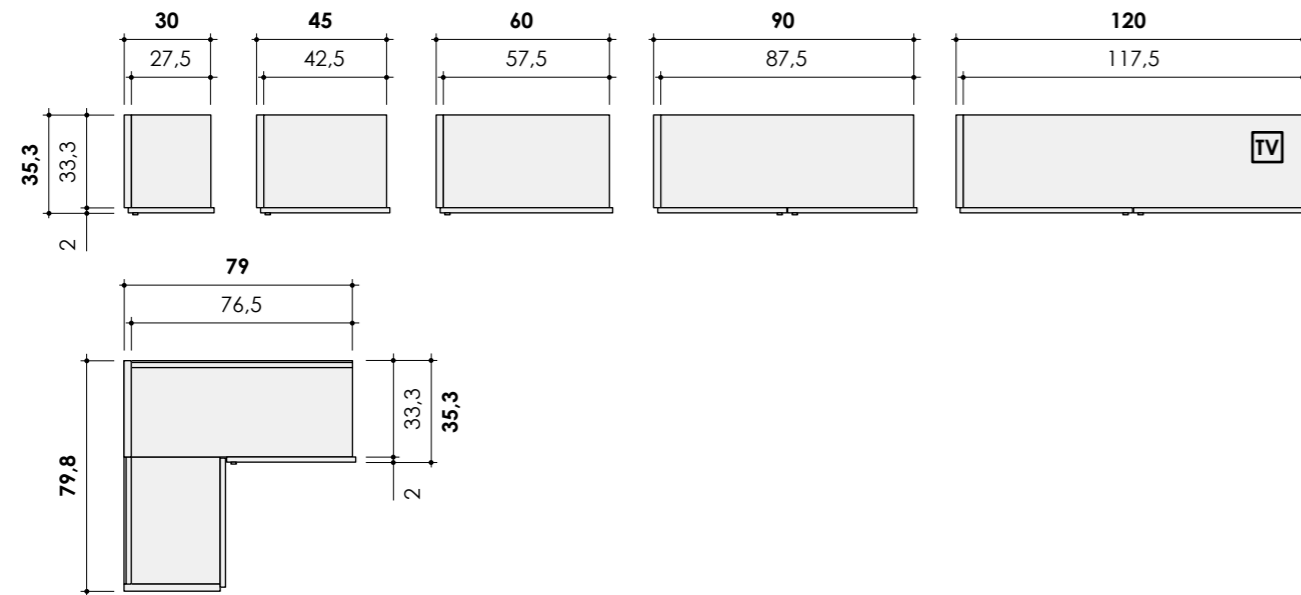

## HEIGHT

The standard distance between each shelf is 32 cm. Upon request, shelves can be positioned every 16 cm.

## SUSPENDED BOOKCASES For top

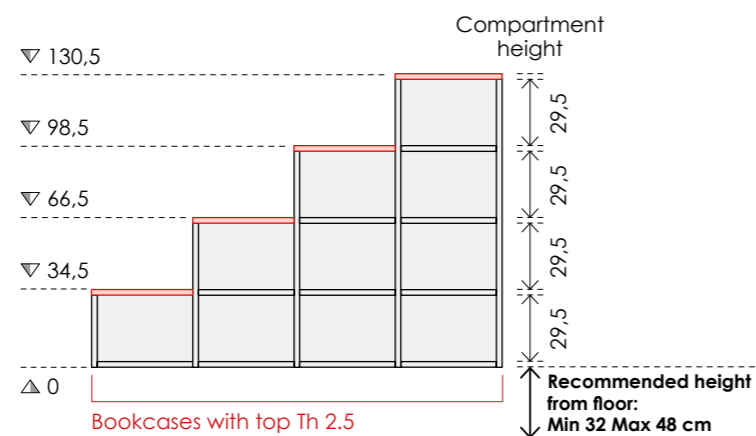

## SUSPENDED BOOKCASES With top finishing insert

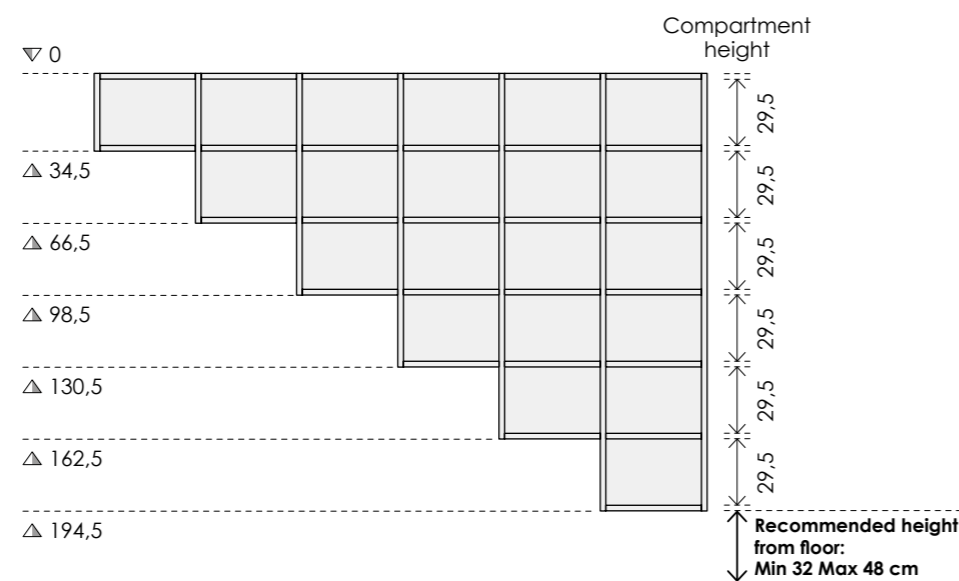

# Suspended Bookcases Dpt 33.3 - Linear assembling

## SOME COMPOSITION EXAMPLES

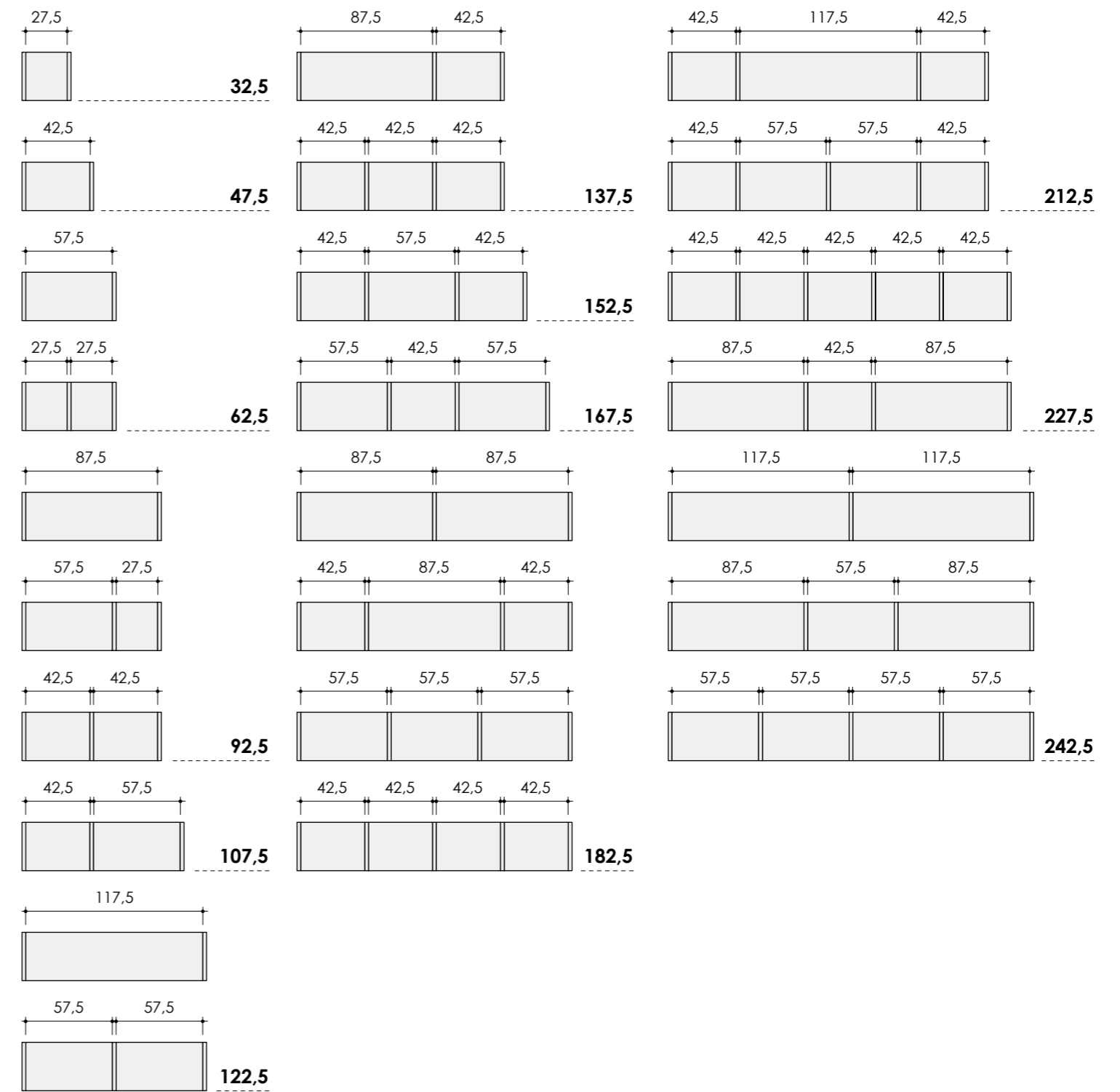

Also with TV compartment

# Suspended Bookcases Dpt 33.3 - For top

With back panel

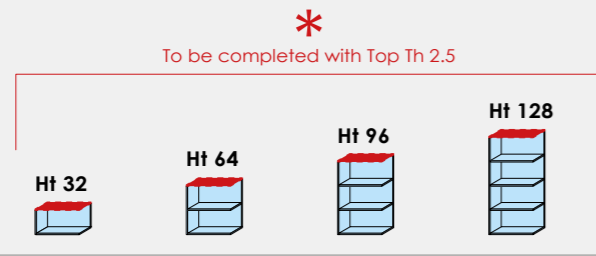

<b>W 30</b>	Code	PL95.00L	PL95.01S	PL95.02Y	PL95.03E				
<b>W 45</b>	Code	PL95.04M	PL95.05T	PL95.06Z	PL95.07F				
<b>W 60</b>	Code	PL95.08N	PL95.09U	PL95.10R	PL95.11X				
<b>W 90</b>	Code	PL95.12D	PL95.13L	PL95.14S	PL95.15Y				

See-through

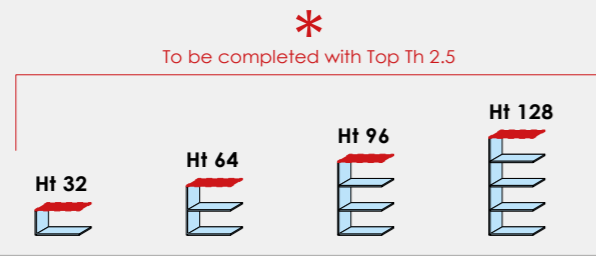

<b>W 30</b>	Code	PL95.20W	PL95.21C	PL95.22K	PL95.23R				
<b>W 45</b>	Code	PL95.24X	PL95.25D	PL95.26L	PL95.27S				
<b>W 60</b>	Code	PL95.28Y	PL95.29E	PL95.30B	PL95.31H				
<b>W 90</b>	Code	PL95.32Q	PL95.33W	PL95.34C	PL95.35K				

Backs  
Th 1.8

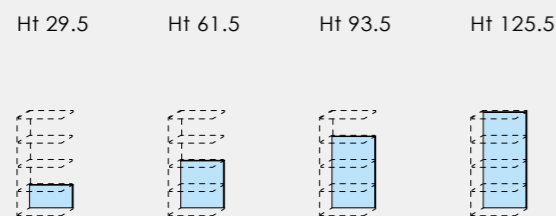

<b>W 30</b>	Code	PL85.64R	PL85.65X	PL85.66D	PL85.67L				
<b>W 45</b>	Code	PL85.72H	PL85.73Q	PL85.74W	PL85.75C				
<b>W 60</b>	Code	PL85.80A	PL85.81G	PL85.82P	PL85.83V				
<b>W 90</b>	Code	PL85.88C	PL85.89K	PL85.90F	PL85.91N				

- Components in **GROUP 2 colors**
- A For bookcases with back
- B For see-through bookcases

Movable shelves

		Melamine-coated Th 2.5			In transparent tempered glass Th 0.8		
		Dpt 30.8 <span style="border: 1px solid black; border-radius: 50%; padding: 2px;">A</span>	Dpt 33.3 <span style="border: 1px solid black; border-radius: 50%; padding: 2px;">B</span>	Dpt 29.8 with led <span style="border: 1px solid black; border-radius: 50%; padding: 2px;">A</span> <span style="border: 1px solid black; border-radius: 50%; padding: 2px;">B</span>	Dpt 28.5 <span style="border: 1px solid black; border-radius: 50%; padding: 2px;">A</span> <span style="border: 1px solid black; border-radius: 50%; padding: 2px;">B</span>	Dpt 28.5 with led <span style="border: 1px solid black; border-radius: 50%; padding: 2px;">A</span> <span style="border: 1px solid black; border-radius: 50%; padding: 2px;">B</span>	
<b>W 27.5</b>	Code	PL86.00M	PL86.01T	-	-	-	Code <b>PL86.17N</b>
<b>W 42.5</b>	Code	PL86.02Z	PL86.03F	PL86.04N	PL86.05U	PL86.06A	Code <b>PL86.18U</b>
<b>W 57.5</b>	Code	PL86.07G	PL86.08P	PL86.09V	PL86.10S	PL86.11Y	
<b>W 87.5</b>	Code	PL86.12E	PL86.13M	PL86.14T	PL86.15Z	PL86.16F	

**led spotlights Ø 6.5**  
We provide a power pack (with a surcharge) able to support from 1 to 6 spotlights. 12 volt 1.7 watt.

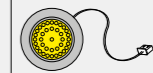

**Wireless switch**  
For led lighting (usable for shelves and for spotlight).

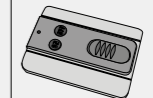

\*

**Top Dpt 33.3 or Th 2.5**  
Max W 360  
Min W 30

per linear metre

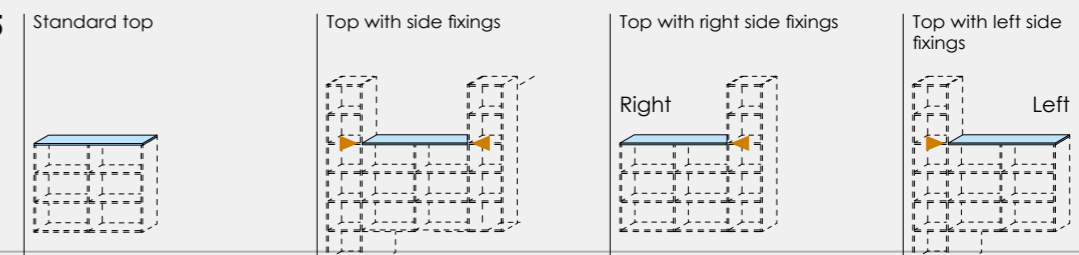

<b>Code</b>	<b>PL86.20X</b>	<b>PL86.21D</b>	<b>PL86.22L</b>	<b>PL86.23S</b>
-------------	-----------------	-----------------	-----------------	-----------------

**Sides for suspended bookcase for top Dpt 33.3 - Th 2.5**

With hardware for wall fixing

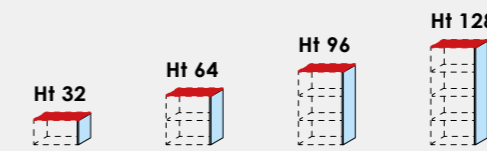

<b>Code</b>	<b>PL95.40G</b>	<b>PL95.41P</b>	<b>PL95.42V</b>	<b>PL95.43B</b>					
-------------	-----------------	-----------------	-----------------	-----------------	--	--	--	--	--

A We provide a power pack (with a surcharge) able to support from 1 to 6 shelves W 45/60 or from 1 to 4 shelves W 90



# Suspended Bookcases Dpt 33.3 - With top finishing insert

With back panel

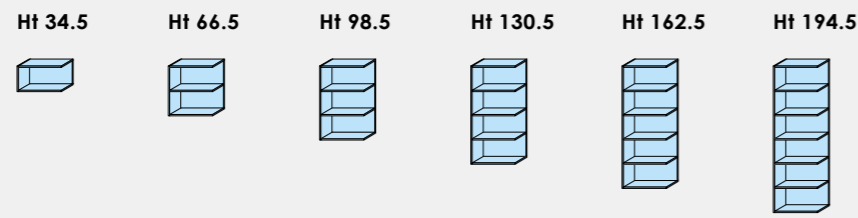

	Code	PL95.50N	PL95.51U	PL95.52A	PL95.53G	PL95.54P	PL95.55V		
<b>W 30</b>									
<b>W 45</b>	Code	PL95.56B	PL95.57H	PL95.58Q	PL95.59W	PL95.60T	PL95.61Z		
<b>W 60</b>	Code	PL95.62F	PL95.63N	PL95.64U	PL95.65A	PL95.66G	PL95.67P		
<b>W 90</b>	Code	PL95.68V	PL95.69B	PL95.70Y	PL95.71E	PL95.72M	PL95.73T		

See-through

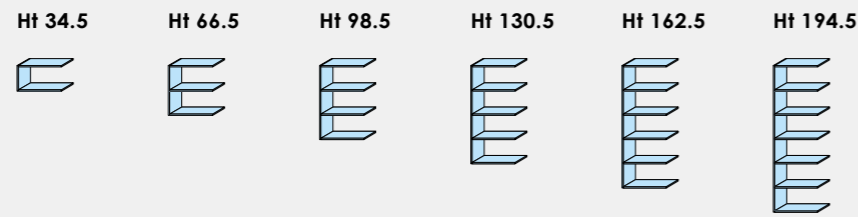

	Code	PL95.75F	PL95.76N	PL95.77U	PL95.78A	PL95.79G	PL95.80D		
<b>W 30</b>									
<b>W 45</b>	Code	PL95.81L	PL95.82S	PL95.83Y	PL95.84E	PL95.85M	PL95.86T		
<b>W 60</b>	Code	PL95.87Z	PL95.88F	PL95.89N	PL95.90K	PL95.91R	PL95.92X		
<b>W 90</b>	Code	PL95.93D	PL95.94L	PL95.95S	PL95.96Y	PL95.97E	PL95.98M		

Backs  
Th 1.8

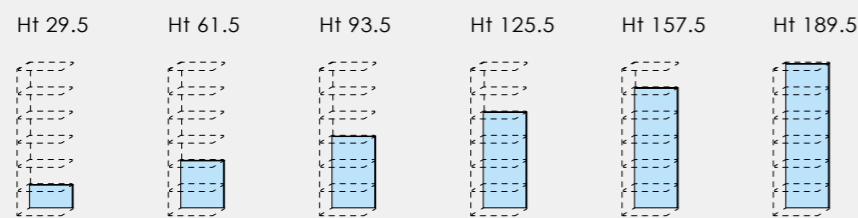

	Code	PL85.64R	PL85.65X	PL85.66D	PL85.67L	PL85.68S	PL85.69Y		
<b>W 30</b>									
<b>W 45</b>	Code	PL85.72H	PL85.73Q	PL85.74W	PL85.75C	PL85.76K	PL85.77R		
<b>W 60</b>	Code	PL85.80A	PL85.81G	PL85.82P	PL85.83V	PL85.84B	PL85.85H		
<b>W 90</b>	Code	PL85.88C	PL85.89K	PL85.90F	PL85.91N	PL85.92U	PL85.93A		

- Components in **GROUP 2 colors**
- For bookcases with back
- For see-through bookcases

Movable shelves

Melamine-coated  
Th 2,5

In transparent tempered  
glass  
Th 0,8

**led spotlights Ø 6.5**  
We provide a power pack (with a surcharge) able to support from 1 to 6 spotlights. 12 volt 1.7 watt.

	Code	PL86.00M	PL86.01T	-	-	-		
<b>W 27.5</b>								
<b>W 42.5</b>	Code	PL86.02Z	PL86.03F	PL86.04N	PL86.05U	PL86.06A		
<b>W 57.5</b>	Code	PL86.07G	PL86.08P	PL86.09V	PL86.10S	PL86.11Y		
<b>W 87.5</b>	Code	PL86.12E	PL86.13M	PL86.14T	PL86.15Z	PL86.16F		

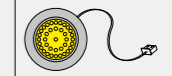

Code	PL86.17N
------	----------

**Wireless switch**  
For led lighting (usable for shelves and for spotlight).

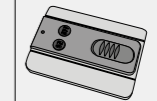

Code	PL86.18U
------	----------

Sides for suspended bookcase with top finishing insert Dpt 33.3 - Th 2.5

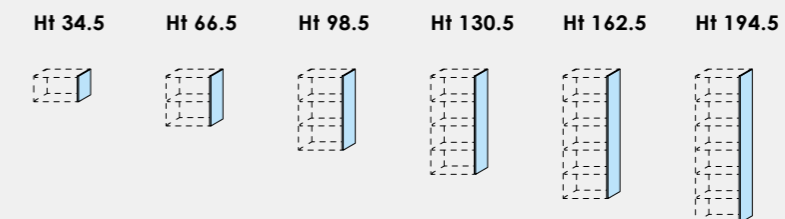

With hardware for wall fixing

Code	PL95.44H	PL95.45Q	PL95.46W	PL95.47C	PL95.48K	PL95.49R		

We provide a power pack (with a surcharge) able to support from 1 to 6 shelves W 45/60 or from 1 to 4 shelves W 90



# Suspended Bookcases Dpt 33.3 - EASY

With back panel

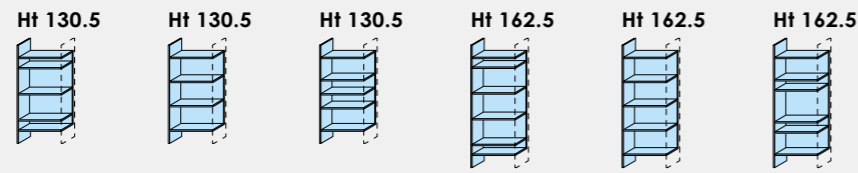

<b>W 30</b>	Code	PL96.00Q	PL96.01W	PL96.02C	PL96.03K	PL96.04R	PL96.05X		
<b>W 45</b>	Code	PL96.06D	PL96.07L	PL96.08S	PL96.09Y	PL96.10V	PL96.11B		
<b>W 60</b>	Code	PL96.12H	PL96.13Q	PL96.14W	PL96.15C	PL96.16K	PL96.17R		

See-through

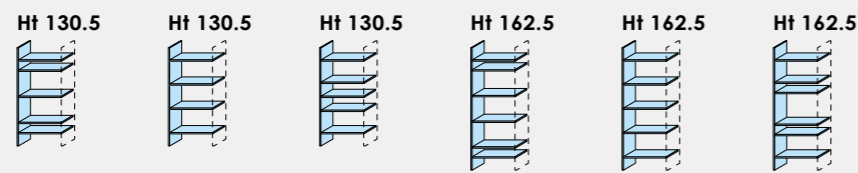

<b>W 30</b>	Code	PL96.18X	PL96.19D	PL96.20A	PL96.21G	PL96.22P	PL96.23V		
<b>W 45</b>	Code	PL96.24B	PL96.25H	PL96.26Q	PL96.27W	PL96.28C	PL96.29K		
<b>W 60</b>	Code	PL96.30F	PL96.31N	PL96.32U	PL96.33A	PL96.34G	PL96.35P		

Backs  
Th 1.8

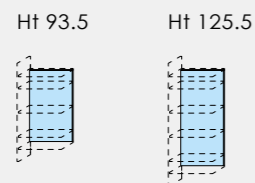

<b>W 27.5</b>	Code	PL85.66D	PL85.67L						
<b>W 42.5</b>	Code	PL85.74W	PL85.75C						
<b>W 57.5</b>	Code	PL85.82P	PL85.83V						

- Components in **GROUP 2 colors**
- For bookcases with back
- For see-through bookcases

Movable shelves

Melamine-coated  
Th 2,5

In transparent tempered glass  
Th 0,8

**led spotlights Ø 6.5**  
We provide a power pack (with a surcharge) able to support from 1 to 6 spotlights. 12 volt 1.7 watt.

		<b>Dpt 30.8</b> 	<b>Dpt 33.3</b> 	<b>Dpt 29.8 with led</b> 	<b>Dpt 28.5</b> 	<b>Dpt 28.5 with led</b> 		
<b>W 27.5</b>	Code	PL86.00M	PL86.01T					
<b>W 42.5</b>	Code	PL86.02Z	PL86.03F	PL86.04N	PL86.05U	PL86.06A		
<b>W 57.5</b>	Code	PL86.07G	PL86.08P	PL86.09V	PL86.10S	PL86.11Y		

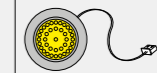

Code	PL86.17N
------	----------

**Wireless switch**  
For led lighting (usable for shelves and for spotlight).

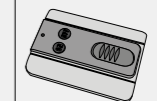

Code	PL86.18U
------	----------

Side panels for  
Suspended  
bookcase EASY  
Dpt 33.3 - Th 2.5

With hardware for wall fixing

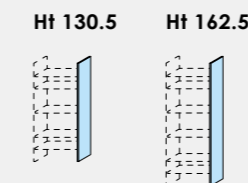

Code	PL96.36V	PL96.37B							
------	----------	----------	--	--	--	--	--	--	--

We provide a power pack (with a surcharge) able to support from 1 to 6 shelves W 45/60 or from 1 to 4 shelves W 90

- p. 732 Doors INFINITY
- p. 735 Drawers INFINITY
- p. 736 Sliding doors INFINITY

# Suspended Bookcases maxi Dpt 33.3 - For top

With back panel

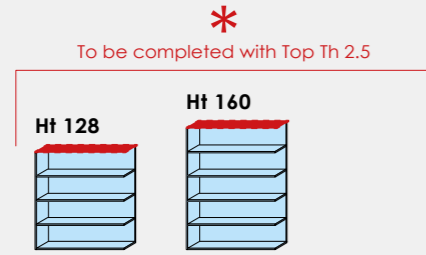

W 120	Code	PL96.50S	PL96.51Y						

See-through

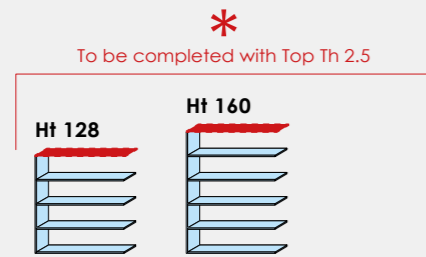

W 120	Code	PL96.52E	PL96.53M						

Side panels  
Suspended  
bookcase for top  
Dpt 33.3 - Th 2.5

With hardware for  
wall fixing

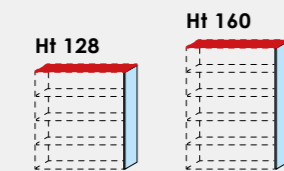

Code	PL96.54T	PL96.55Z							
------	----------	----------	--	--	--	--	--	--	--

\*  
Top Dpt 33.3 - Th 2.5  
Max W 360  
Min W 30  
per linear metre

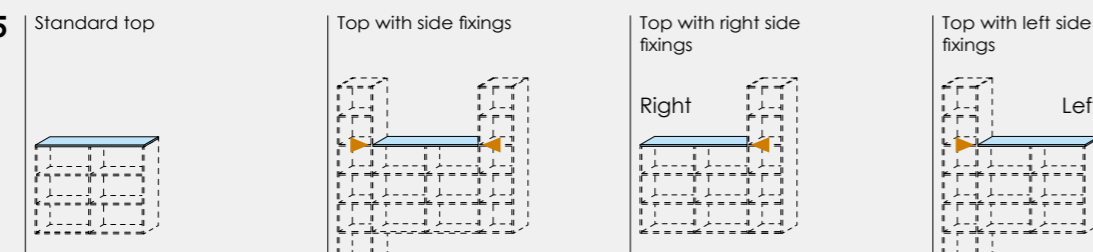

Code	PL86.20X	PL86.21D	PL86.22L	PL86.23S
------	----------	----------	----------	----------

Components in GROUP 2 colors

# Suspended Bookcases maxi Dpt 33.3 - With top finishing insert

With back panel

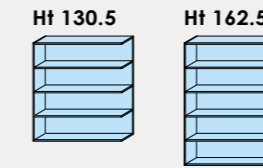

W 120	Code	PL96.60X	PL96.61D						

See-through

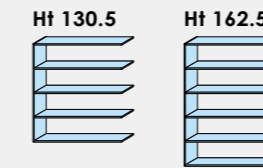

W 120	Code	PL96.62L	PL96.63S						

Side panels for  
Suspended  
bookcase with  
top finishing insert  
Dpt 33.3 - Th 2.5

With hardware for  
wall fixing

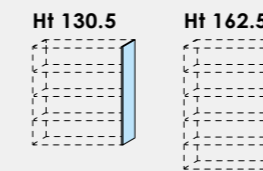

Code	PL95.47C	PL95.48K							
------	----------	----------	--	--	--	--	--	--	--

### IMPORTANT:

The bookcases proposed in these pages must be completed with dividing panels with support function.

Consult following pages for codes and application.

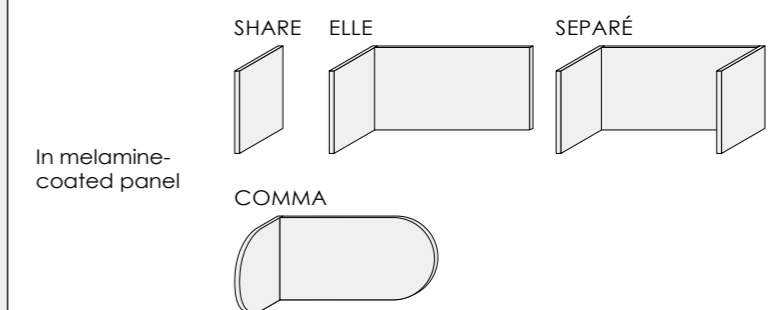

Backs  
Th 1.8

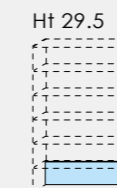



W 117.5	Code	PL87.50T	

# Suspended Bookcases maxi Dpt 33.3 - Dividing panels

## Melamine-faced dividing panels Ht 29.5



Load-bearing

Can be equipped with standard doors and drawers.

SHARE (A)		SHARE (B)	
Th 2.5		Th 2.5	
<b>Dpt</b>	<b>Code</b>	<b>Dpt</b>	<b>Code</b>
30.8	PL87.70D	33.3	PL87.71L



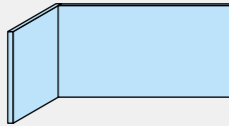
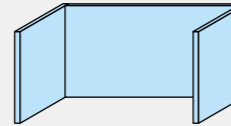

## Melamine-faced dividing panels Ht 29.5

Load-bearing

ELLE (B)		SEPARÉ (B)		COMMA (B)	
Dpt 30.8 Th 2.5		Dpt 30.8 Th 2.5		Dpt 30.8 Th 2.5	
<b>W</b>	<b>Code</b>	<b>W</b>	<b>Code</b>	<b>W</b>	<b>Code</b>
30	PL87.72S	32.5	PL87.77Z	30	PK83.64E
45	PL87.73Y	47.5	PL87.78F	45	PK83.65M
60	PL87.74E	62.5	PL87.79N	60	PK83.66T
75	PL87.75M	77.5	PL87.80K	75	PK83.67Z
90	PL87.76T	92.5	PL87.81R	90	PK83.68F

## Movable shelves

use with dividing panels  
SHARE

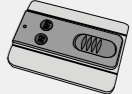

W	Code	Melamine-coated Th 2,5			In transparent tempered glass Th 0,8		Code	led spotlights Ø 6.5 We provide a power pack (with a surcharge) able to support from 1 to 6 spotlights. 12 volt 1.7 watt.
		Dpt 30.8 	Dpt 33.3 	Dpt 29.8 with led 	Dpt 28.5 	Dpt 28.5 with led 		
<b>W 27.5</b>		PL86.00M	PL86.01T	-	-	-	PL86.17N	
<b>W 42.5</b>		PL86.02Z	PL86.03F	PL86.04N	PL86.05U	PL86.06A	Wireless switch For led lighting (usable for shelves and for spotlight). 	
<b>W 57.5</b>		PL86.07G	PL86.08P	PL86.09V	PL86.10S	PL86.11Y		
<b>W 87.5</b>		PL86.12E	PL86.13M	PL86.14T	PL86.15Z	PL86.16F		
							Code	PL86.18U

## Dividing panel positioning instructions

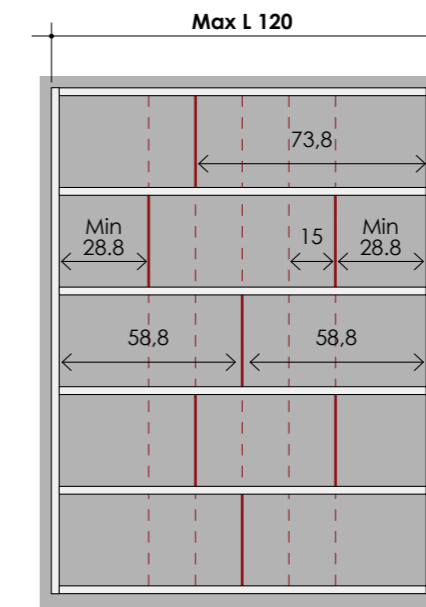
The grid in each horizontal section is divided every 15 cm.  
Dividing panels must be mounted following the instruction below:  
**SIDE compartments L Max 73.8 - Min 28.8 cm.**  
**MIDDLE compartments L Max 75 - Min 30 cm.**  
The position of **load-bearing** dividing panels establishes the holes on the above and below shelves.



 We provide a power pack (with a surcharge) able to support from 1 to 6 shelves W 45/60 or from 1 to 4 shelves W 90

-  Components in **GROUP 2 colors**
-  For bookcases with back
-  For see-through bookcases

-  p. 732 Doors INFINITY
- p. 735 Drawers INFINITY
- p. 736 Sliding doors INFINITY

# Suspended Bookcases Dpt 33.3 - Semi-suspended

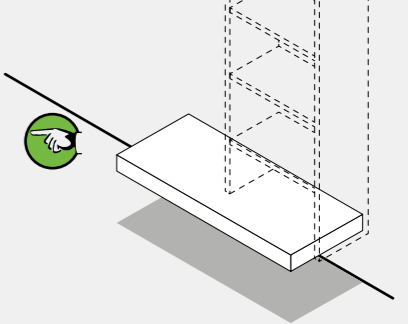

on suspended desk PODIO Ht 8

With back panel

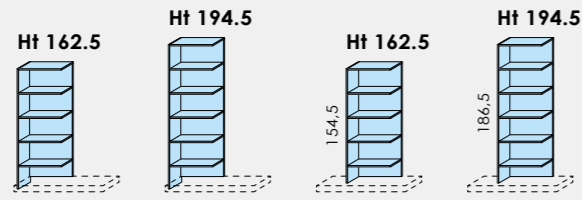

<b>W 30</b>	Code	PL96.70C	PL96.71K	PL96.72R	PL96.73X				
<b>W 45</b>	Code	PL96.74D	PL96.75L	PL96.76S	PL96.77Y				
<b>W 60</b>	Code	PL96.78E	PL96.79M	PL96.80H	PL96.81Q				
<b>W 90</b>	Code	PL96.82W	PL96.83C	PL96.84K	PL97.03P				

See-through

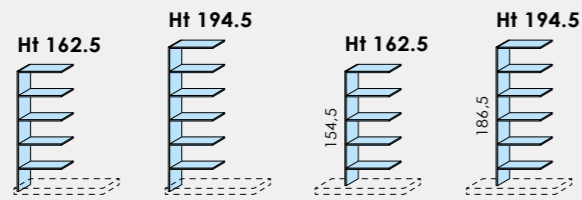

<b>W 30</b>	Code	PL96.85R	PL96.86X	PL96.87D	PL96.88L				
<b>W 45</b>	Code	PL96.89S	PL96.90P	PL96.91V	PL96.92B				
<b>W 60</b>	Code	PL96.93H	PL96.94Q	PL96.95W	PL96.96C				
<b>W 90</b>	Code	PL96.97K	PL96.98R	PL96.99X	PL97.00U				

Backs Th 1.8

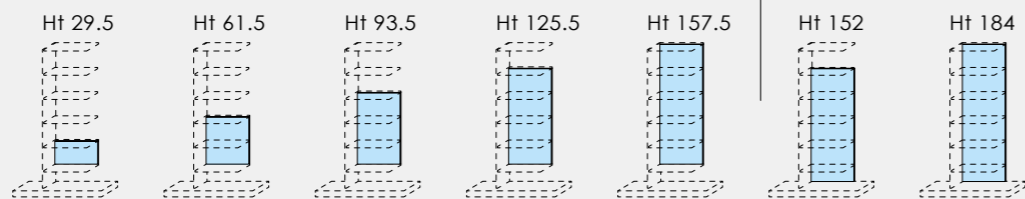

<b>W 27.5</b>	Code	PL85.64R	PL85.65X	PL85.66D	PL85.67L	PL85.68S	PL97.05B	PL97.06H				
<b>W 42.5</b>	Code	PL85.72H	PL85.73Q	PL85.74W	PL85.75C	PL85.76K	PL97.07Q	PL97.08W				
<b>W 57.5</b>	Code	PL85.80A	PL85.81G	PL85.82P	PL85.83V	PL85.84B	PL97.09C	PL97.10Z				
<b>W 87.5</b>	Code	PL85.88C	PL85.89K	PL85.90F	PL85.91N	PL85.92U	PL97.11F	PL97.12N				

- Components in **GROUP 2 colors**
- A For bookcases with back
- B For see-through bookcases

Movable shelves

		Melamine-coated Th 2,5			In transparent tempered glass Th 0,8		
		Dpt 30.8	Dpt 33.3	Dpt 29.8 with led	Dpt 28.5	Dpt 28.5 with led	
		<span style="border: 1px solid black; border-radius: 50%; padding: 2px;">A</span>	<span style="border: 1px solid black; border-radius: 50%; padding: 2px;">B</span>	<span style="border: 1px solid black; border-radius: 50%; padding: 2px;">A</span> <span style="border: 1px solid black; border-radius: 50%; padding: 2px;">B</span>	<span style="border: 1px solid black; border-radius: 50%; padding: 2px;">A</span> <span style="border: 1px solid black; border-radius: 50%; padding: 2px;">B</span>	<span style="border: 1px solid black; border-radius: 50%; padding: 2px;">A</span> <span style="border: 1px solid black; border-radius: 50%; padding: 2px;">B</span>	
<b>W 27.5</b>	Code	PL86.00M	PL86.01T	-	-	-	
<b>W 42.5</b>	Code	PL86.02Z	PL86.03F	PL86.04N	PL86.05U	PL86.06A	
<b>W 57.5</b>	Code	PL86.07G	PL86.08P	PL86.09V	PL86.10S	PL86.11Y	
<b>W 87.5</b>	Code	PL86.12E	PL86.13M	PL86.14T	PL86.15Z	PL86.16F	

**led spotlights Ø 6.5**  
We provide a power pack (with a surcharge) able to support from 1 to 6 spotlights. 12 volt 1.7 watt.



Code	PL86.17N
------	----------

**Wireless switch**  
For led lighting (usable for shelves and for spotlight).

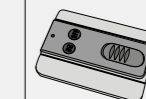

Code	PL86.18U
------	----------

Semi-suspended side panels for suspended bookcase Dpt 33.3 - Th 2.5 for PODIO

With hardware for wall fixing

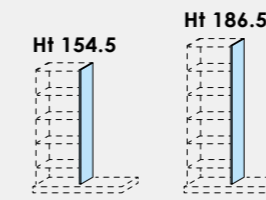

Code	PL97.01A	PL97.02G							
------	----------	----------	--	--	--	--	--	--	--

Drawers and doors can not be mounted on this compartment (⊗).

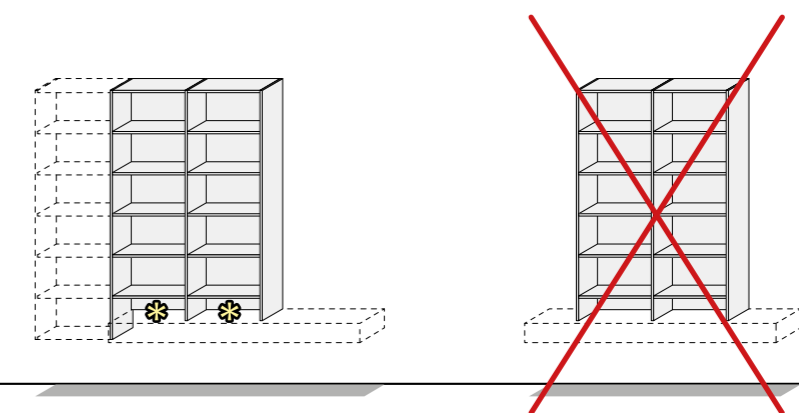

B We provide a power pack (with a surcharge) able to support from 1 to 6 shelves W 45/60 or from 1 to 4 shelves W 90

- B p. 732 Doors INFINITY
- p. 735 Drawers INFINITY
- p. 736 Sliding doors INFINITY

# Suspended Bookcases Dpt 33.3 - Semi-suspended

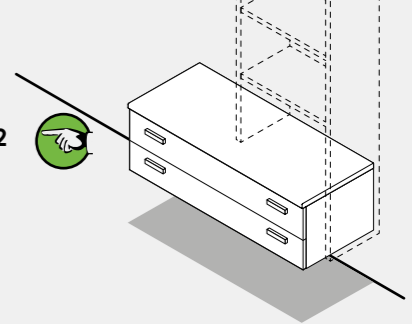

on Modular suspended component Ht 32 + top Th 2.5

With back panel

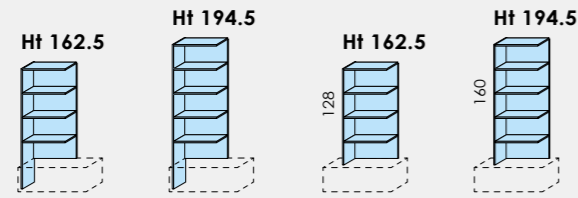

<b>W 30</b>	Code	PL97.62Q	PL97.63W	PL97.64V	PL97.65K				
<b>W 45</b>	Code	PL97.66R	PL97.67X	PL97.68D	PL97.69L				
<b>W 60</b>	Code	PL97.70G	PL97.71P	PL97.72V	PL97.73B				
<b>W 90</b>	Code	PL97.74H	PL97.75Q	PL97.76W	PL97.77C				

See-through

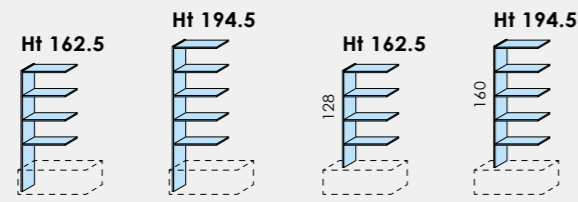

<b>W 30</b>	Code	PL97.78K	PL97.79R	PL97.80N	PL97.81U				
<b>W 45</b>	Code	PL97.82A	PL97.83G	PL97.84P	PL97.85V				
<b>W 60</b>	Code	PL97.86B	PL97.87H	PL97.88Q	PL97.89W				
<b>W 90</b>	Code	PL97.90T	PL97.91Z	PL97.92F	PL97.93N				

Backs Th 1.8

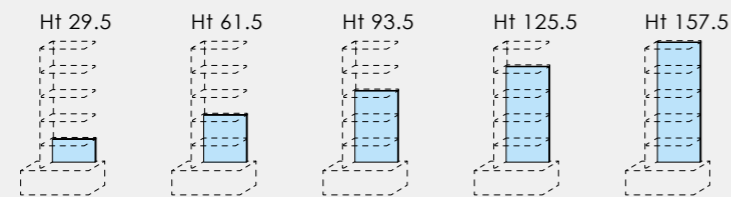

<b>W 27.5</b>	Code	PL85.64R	PL85.65X	PL85.66D	PL85.67L	PL85.68S				
<b>W 42.5</b>	Code	PL85.72H	PL85.73Q	PL85.74W	PL85.75C	PL85.76K				
<b>W 57.5</b>	Code	PL85.80A	PL85.81G	PL85.82P	PL85.83V	PL85.84B				
<b>W 87.5</b>	Code	PL85.88C	PL85.89K	PL85.90F	PL85.91N	PL85.92U				

- Components in **GROUP 2 colors**
- For bookcases with back
- For see-through bookcases

Movable shelves

Melamine-coated Th 2,5

Dpt 30.8 Dpt 33.3 Dpt 29.8 with led In transparent tempered glass Th 0,8

Dpt 28.5 Dpt 28.5 with led

<b>W 27.5</b>	Code	PL86.00M	PL86.01T	-	-	-
<b>W 42.5</b>	Code	PL86.02Z	PL86.03F	PL86.04N	PL86.05U	PL86.06A
<b>W 57.5</b>	Code	PL86.07G	PL86.08P	PL86.09V	PL86.10S	PL86.11Y
<b>W 87.5</b>	Code	PL86.12E	PL86.13M	PL86.14T	PL86.15Z	PL86.16F

**led spotlights Ø 6.5**  
We provide a power pack (with a surcharge) able to support from 1 to 6 spotlights. 12 volt 1.7 watt.



Code	PL86.17N
------	----------

**Wireless switch**  
For led lighting (usable for shelves and for spotlight).

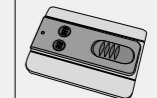

Code	PL86.18U
------	----------

Semi-suspended side panels for suspended bookcase Dpt 33.3 - Th 2.5

for Modular components H 32

With hardware for wall fixing

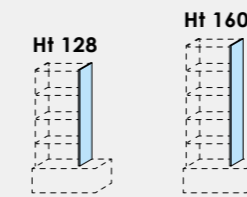

Code	PL97.94U	PL97.95A							
------	----------	----------	--	--	--	--	--	--	--

Drawers and doors can not be mounted on this compartment .

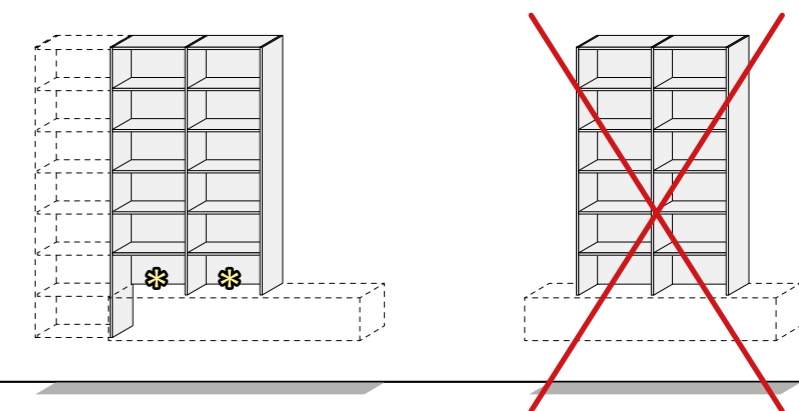

We provide a power pack (with a surcharge) able to support from 1 to 6 shelves W 45/60 or from 1 to 4 shelves W 90

## Suspended Bookcases Dpt 33.3 - Overhead units

## Suspended corner Bookcases Dpt 33.3 - Full corner

		With back panel			See-through		
		* To be completed with Bottom panel Th 2.5			* To be completed with Bottom panel Th 2.5		
With hardware for wall fixing		Ht 32	Ht 64	Ht 96	Ht 32	Ht 64	Ht 96
<b>W 30</b>	Code	PL98.00Y	PL98.01E	PL98.02M	PL98.12S	PL98.13Y	PL98.14E
<b>W 45</b>	Code	PL98.03T	PL98.04Z	PL98.05F	PL98.15M	PL98.16T	PL98.17Z
<b>W 60</b>	Code	PL98.06N	PL98.07U	PL98.08A	PL98.18F	PL98.19N	PL98.20K
<b>W 90</b>	Code	PL98.09G	PL98.10D	PL98.11L	PL98.21R	PL98.22X	PL98.23D

Backs  
Th 1.8

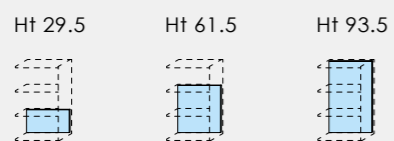

Suspended side panels for Overhead Units Dpt 33.3 - Th 2.5

With hardware for wall fixing

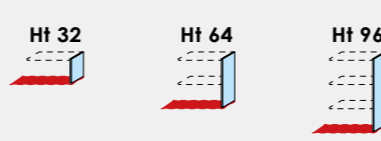

<b>W 30</b>	Code	PL85.64R	PL85.65X	PL85.66D	Code	PL98.24L	PL98.25S	PL98.26Y
<b>W 45</b>	Code	PL85.72H	PL85.73Q	PL85.74W				
<b>W 60</b>	Code	PL85.80A	PL85.81G	PL85.82P				
<b>W 90</b>	Code	PL85.88C	PL85.89K	PL85.90F				

\*  
**Bottom panel**  
Dpt 33.3 - Th 2.5  
Max W 360  
Min W 30  
per linear metre

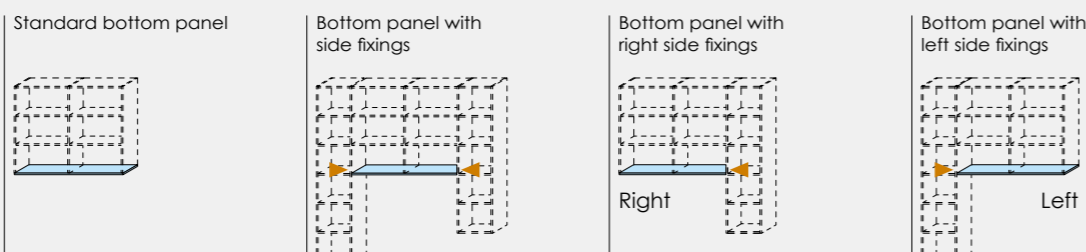

Code	PL98.27E	PL98.28M	PL98.29T	PL98.30Q
------	----------	----------	----------	----------

- Components in **GROUP 2** colors
- A For bookcases with back
- B For see-through bookcases

With back panel

See-through

		With back panel						Movable shelves
		Ht 34.5	Ht 66.5	Ht 98.5	Ht 130.5	Ht 162.5	Ht 194.5	Melamine-coated Dpt 30.8 Th 2.5
Code		PL98.31W	PL98.32C	PL98.33K	PL98.34R	PL98.35X	PL98.36D	PL91.21L
		See-through						Melamine-coated Dpt 33.3 Th 2.5
		Ht 34.5	Ht 66.5	Ht 98.5	Ht 130.5	Ht 162.5	Ht 194.5	
Code		PL98.37L	PL98.38S	PL98.39Y	PL98.40V	PL98.41B	PL98.42H	PL91.22S

Suspended side panels for full Corner Dpt 33.3 - Th 2.5

With hardware for wall fixing

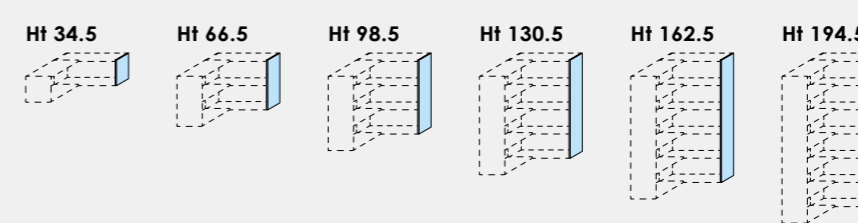

Code	PL95.44H	PL95.45Q	PL95.46W	PL95.47C	PL95.48K	PL95.49R
------	----------	----------	----------	----------	----------	----------

### Technical information

- Available in open version or with pair of doors. Handle is always provided on the Right door.
- Size proportion changes are not available.
- Customized size reductions are not available.

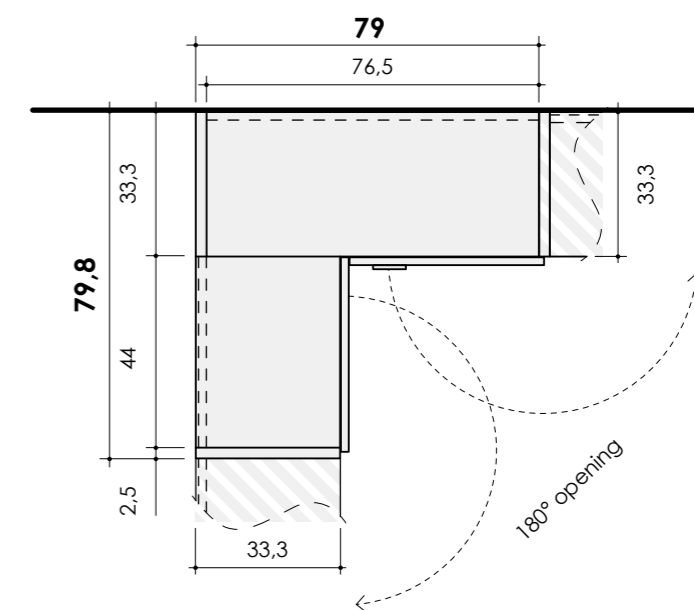



# Suspended Bookcases Dpt 33.3 - For top with TV compartment

With back panel

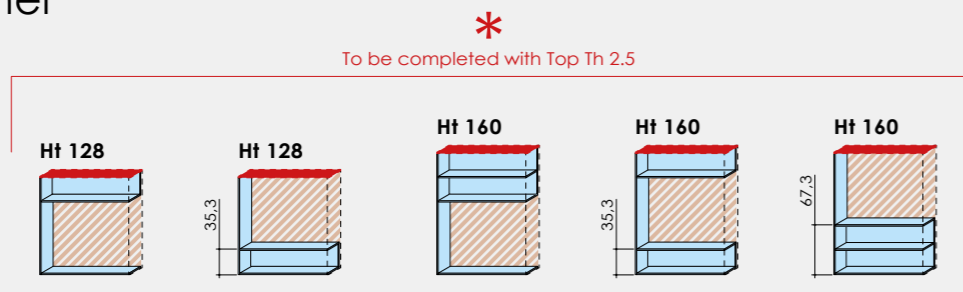

<b>W 120</b>	<b>Code</b>	<b>PL98.45C</b>	<b>PL98.46K</b>	<b>PL98.47R</b>	<b>PL98.48X</b>	<b>PL98.49D</b>
--------------	-------------	-----------------	-----------------	-----------------	-----------------	-----------------

See-through

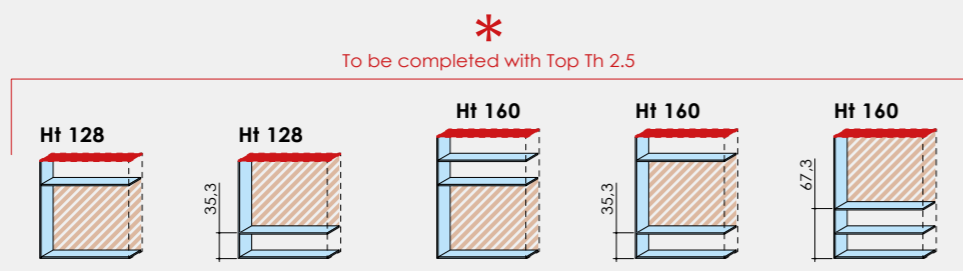

<b>W 120</b>	<b>Code</b>	<b>PL98.50A</b>	<b>PL98.51G</b>	<b>PL98.52P</b>	<b>PL98.53V</b>	<b>PL98.54B</b>
--------------	-------------	-----------------	-----------------	-----------------	-----------------	-----------------

TV compartments with lighting system

Always order one for every composition.

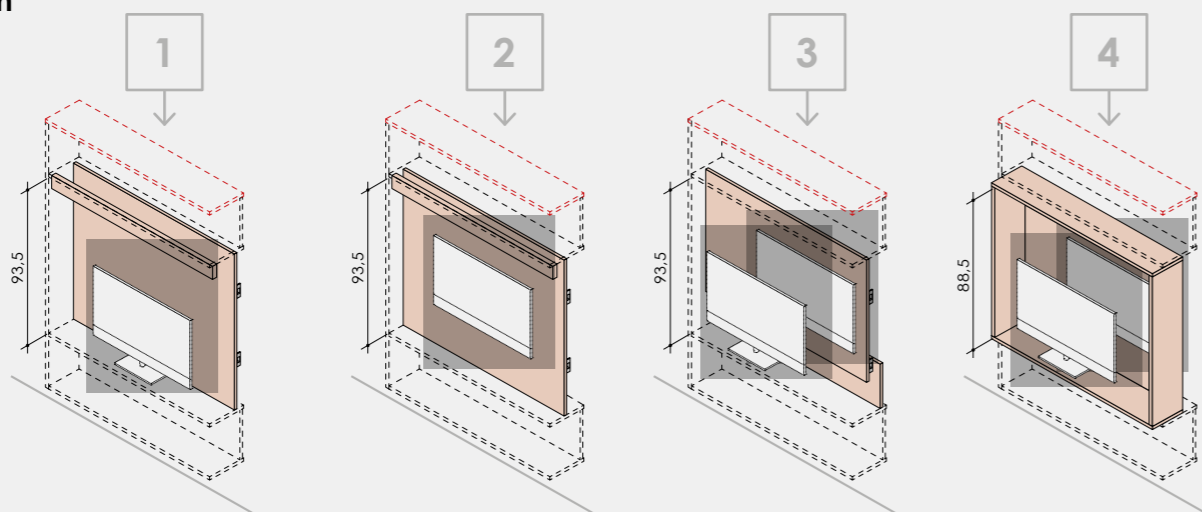

<b>W 120</b>	<b>Code</b>	<b>PL93.60K</b>	<b>PL93.61R</b>	<b>PL93.62X</b>	<b>PL93.63D</b>
--------------	-------------	-----------------	-----------------	-----------------	-----------------

\* Top Dpt 33.3 - Th 2.5

Max W 360  
Min W 30  
per linear metre

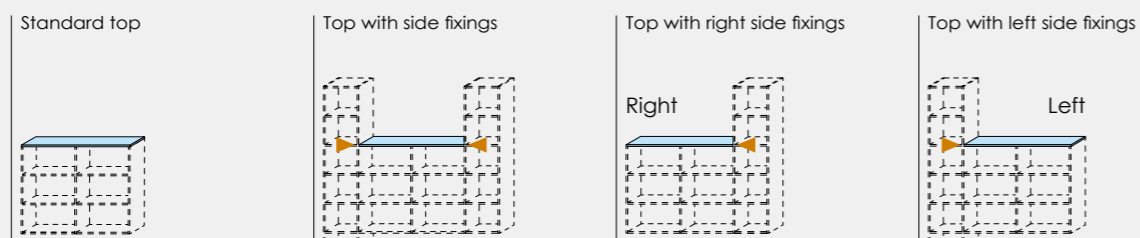

<b>Code</b>	<b>PL87.56G</b>	<b>PL87.57P</b>	<b>PL87.58V</b>	<b>PL87.59B</b>
-------------	-----------------	-----------------	-----------------	-----------------

- Components in **GROUP 2 colors**
- Components in **GROUP 3 colors**
- For bookcases with back
- For see-through bookcases

Backs  
Th 1.8



<b>W 117.5</b>	<b>Code</b>	<b>PL87.50T</b>	<b>PL98.72Z</b>	<b>PL98.73F</b>
----------------	-------------	-----------------	-----------------	-----------------

Suspended side panels  
Dpt 33.3 - Th 2.5

With hardware for wall fixing

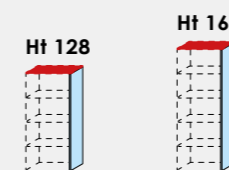

<b>Code</b>	<b>PL95.43B</b>	<b>PL96.55Z</b>
-------------	-----------------	-----------------

Melamine-faced dividing panels  
Ht 29.5 - Th 2.5

Load-Bearing

Can be equipped with standard doors and drawers.

SHARE Dpt 30.8	SHARE Dpt 33.3	ELLE Dpt 30.8 Th 2.5	SEPARÉ Dpt 30.8 Th 2.5
<b>W</b>	<b>Code</b>	<b>W</b>	<b>Code</b>
30	<b>PL87.72S</b>	32.5	<b>PL87.77Z</b>
45	<b>PL87.73Y</b>	47.5	<b>PL87.78F</b>
60	<b>PL87.74E</b>	62.5	<b>PL87.79N</b>
<b>Code</b>	<b>PL87.70D</b>	<b>Code</b>	<b>PL87.80K</b>
	<b>PL87.71L</b>	75	<b>PL87.81R</b>
		90	

Movable shelves

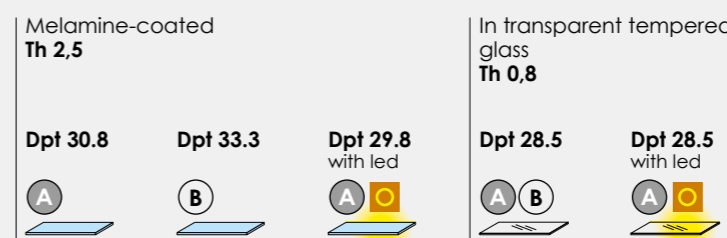

<b>W 27.5</b>	<b>Code</b>	<b>PL86.00M</b>	<b>PL86.01T</b>	-	-	-
<b>W 42.5</b>	<b>Code</b>	<b>PL86.02Z</b>	<b>PL86.03F</b>	<b>PL86.04N</b>	<b>PL86.05U</b>	<b>PL86.06A</b>
<b>W 57.5</b>	<b>Code</b>	<b>PL86.07G</b>	<b>PL86.08P</b>	<b>PL86.09V</b>	<b>PL86.10S</b>	<b>PL86.11Y</b>
<b>W 87.5</b>	<b>Code</b>	<b>PL86.12E</b>	<b>PL86.13M</b>	<b>PL86.14T</b>	<b>PL86.15Z</b>	<b>PL86.16F</b>

We provide a power pack (with a surcharge) able to support from 1 to 6 shelves W 45/60 or from 1 to 4 shelves W 90

Dividing panel positioning instructions

The grid in each horizontal section is divided every 15 cm. Dividing panels must be mounted following the instruction below:  
**SIDE compartments L Max 73.8 - Min 28.8 cm.**  
**MIDDLE compartments L Max 75 - Min 30 cm.**  
The position of **load-bearing** dividing panels establishes the holes on the above and below shelves.

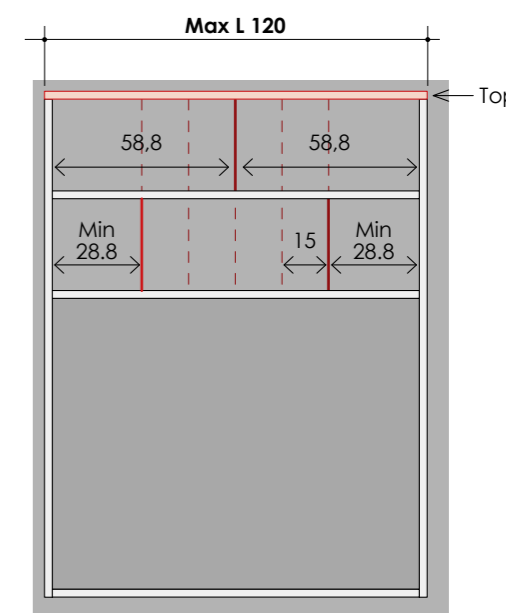

**led spotlights Ø 6.5**  
We provide a power pack (with a surcharge) able to support from 1 to 6 spotlights. 12 volt 1.7 watt.

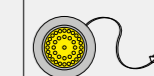

<b>Code</b>	<b>PL86.17N</b>
-------------	-----------------

**Wireless switch**  
For led lighting (usable for shelves and for spotlight).

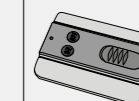

<b>Code</b>	<b>PL86.18U</b>
-------------	-----------------

# Suspended Bookcases Dpt 33.3 - With TV compartment and top finishing insert

With back panel

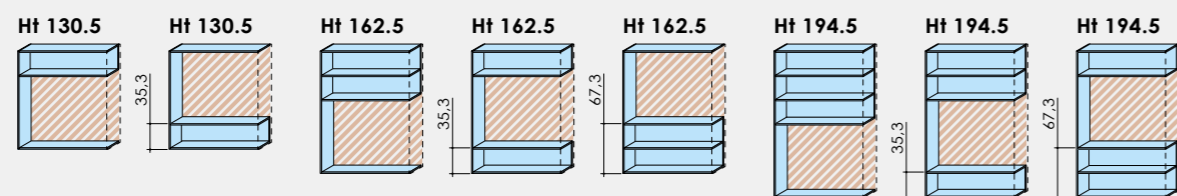

W 120	Code	PL98.55H	PL98.56Q	PL98.57W	PL98.58C	PL98.59K	PL98.60F	PL98.61N	PL98.62U

See-through

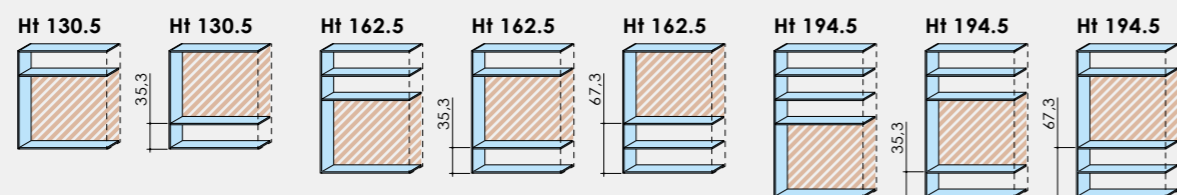

W 120	Code	PL98.63A	PL98.64G	PL98.65P	PL98.66V	PL98.67B	PL98.68H	PL98.69Q	PL98.70M
									317,00

TV compartments with lighting system

Always order one for every composition.

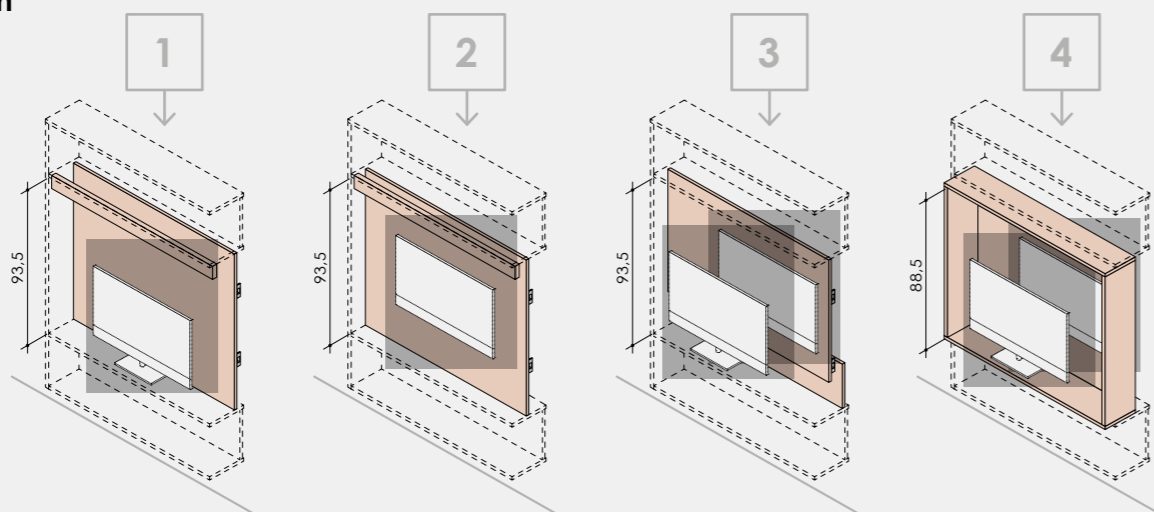

W 120	Code	PL93.60K	PL93.61R	PL93.62X	PL93.63D

- Components in **GROUP 2 colors**
- Components in **GROUP 3 colors**
- A For bookcases with back
- B For see-through bookcases

Backs Th 1.8



W 117.5	Code	PL87.50T	PL98.72Z	PL98.73F

Suspended side panels Dpt 33.3 - Th 2.5

With hardware for wall fixing

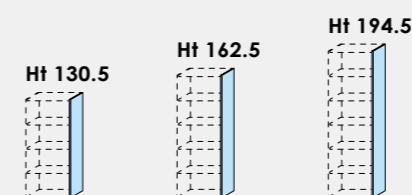

Code	PL96.64Y	PL96.65E	PL96.74N

Melamine-faced dividing panels Ht 29.5 - Th 2.5

Load-Bearing

Can be equipped with standard doors and drawers.

SHARE Dpt 30.8	SHARE Dpt 33.3	ELLE Dpt 30.8 Th 2.5	SEPARÉ Dpt 30.8 Th 2.5
<span style="border: 1px solid black; border-radius: 50%; padding: 2px;">A</span>	<span style="border: 1px solid black; border-radius: 50%; padding: 2px;">B</span>	<span style="border: 1px solid black; border-radius: 50%; padding: 2px;">B</span>	<span style="border: 1px solid black; border-radius: 50%; padding: 2px;">B</span>
<span style="border: 1px solid black; border-radius: 50%; padding: 2px;">A</span>	<span style="border: 1px solid black; border-radius: 50%; padding: 2px;">B</span>	<span style="border: 1px solid black; border-radius: 50%; padding: 2px;">B</span>	<span style="border: 1px solid black; border-radius: 50%; padding: 2px;">B</span>
<b>W</b>	<b>Code</b>	<b>W</b>	<b>Code</b>
30	PL87.72S	32.5	PL87.77Z
45	PL87.73Y	47.5	PL87.78F
60	PL87.74E	62.5	PL87.79N
<b>Code</b>	<b>PL87.70D</b>	<b>75</b>	<b>PL87.80K</b>
		<b>90</b>	<b>PL87.81R</b>

Movable shelves

Melamine-coated Th 2,5	In transparent tempered glass Th 0,8	led spotlights Ø 6.5
Dpt 30.8 <span style="border: 1px solid black; border-radius: 50%; padding: 2px;">A</span>	Dpt 33.3 <span style="border: 1px solid black; border-radius: 50%; padding: 2px;">B</span>	Dpt 29.8 with led <span style="border: 1px solid black; border-radius: 50%; padding: 2px;">A</span>
<span style="border: 1px solid black; border-radius: 50%; padding: 2px;">A</span>	<span style="border: 1px solid black; border-radius: 50%; padding: 2px;">B</span>	<span style="border: 1px solid black; border-radius: 50%; padding: 2px;">A</span>
<b>Dpt 28.5</b>	<b>Dpt 28.5 with led</b>	
<span style="border: 1px solid black; border-radius: 50%; padding: 2px;">A</span>	<span style="border: 1px solid black; border-radius: 50%; padding: 2px;">B</span>	<span style="border: 1px solid black; border-radius: 50%; padding: 2px;">A</span>
<b>Code</b>	<b>Code</b>	<b>Code</b>
PL86.00M	PL86.01T	PL86.17N

W 27.5	Code	PL86.02Z	PL86.03F	PL86.04N	PL86.05U	PL86.06A
W 42.5	Code	PL86.07G	PL86.08P	PL86.09V	PL86.10S	PL86.11Y
W 57.5	Code	PL86.12E	PL86.13M	PL86.14T	PL86.15Z	PL86.16F
W 87.5	Code					

We provide a power pack (with a surcharge) able to support from 1 to 6 shelves W 45/60 or from 1 to 4 shelves W 90

**Wireless switch**  
For led lighting (usable for shelves and for spotlight).

	<b>Code</b>	<b>PL86.18U</b>
--	-------------	-----------------

Dividing panel positioning instructions

The grid in each horizontal section is divided every 15 cm. Dividing panels must be mounted following the instruction below:  
**SIDE compartments L Max 73.8 - Min 28.8 cm.**  
**MIDDLE compartments L Max 75 - Min 30 cm.**  
 The position of **load-bearing** dividing panels establishes the holes on the above and below shelves.

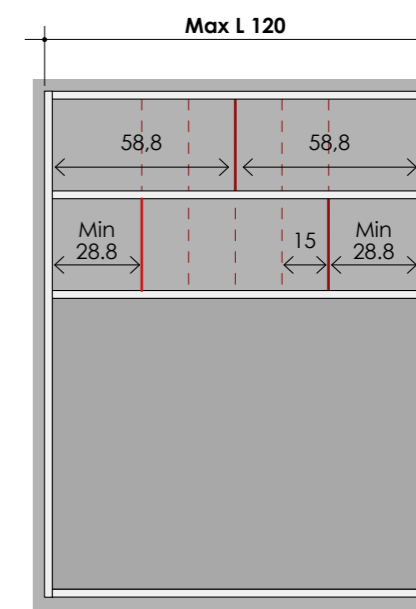

# DOCKS modular units for bookcases INFINITY Dpt 33.3

## Open DOCKS

- They are containers which can be stored in the open compartment of the Bookcase. The shelves in between DOCKS must be successfully blocked.
- They are without back panel and are provided with a non modifiable inside partition.
- They are 42.4 cm deep and they protrude for 9 cm from the front of the bookcase or 4.5 cm from both sides.
- Customer must take care of assembling.

## Suspended DOCK unit with door

- They are wall units provided with an invisible and unhooking wall fixing system and they can not be placed inside the Bookcases.
- They are always supplied with back panel and are provided with a non modifiable inside partition.
- They are 44.3 cm deep and they protrude for 11 cm from the front of the bookcase.
- Customer must take care of assembling.
- The doors are fitted with decelerated hinges.
- The doors are also available with push pull (not on CLUB and WINDOW).

## Components

- Carcase Th 1.8 cm.
- Melamine-faced shelves Th 1.8 cm.

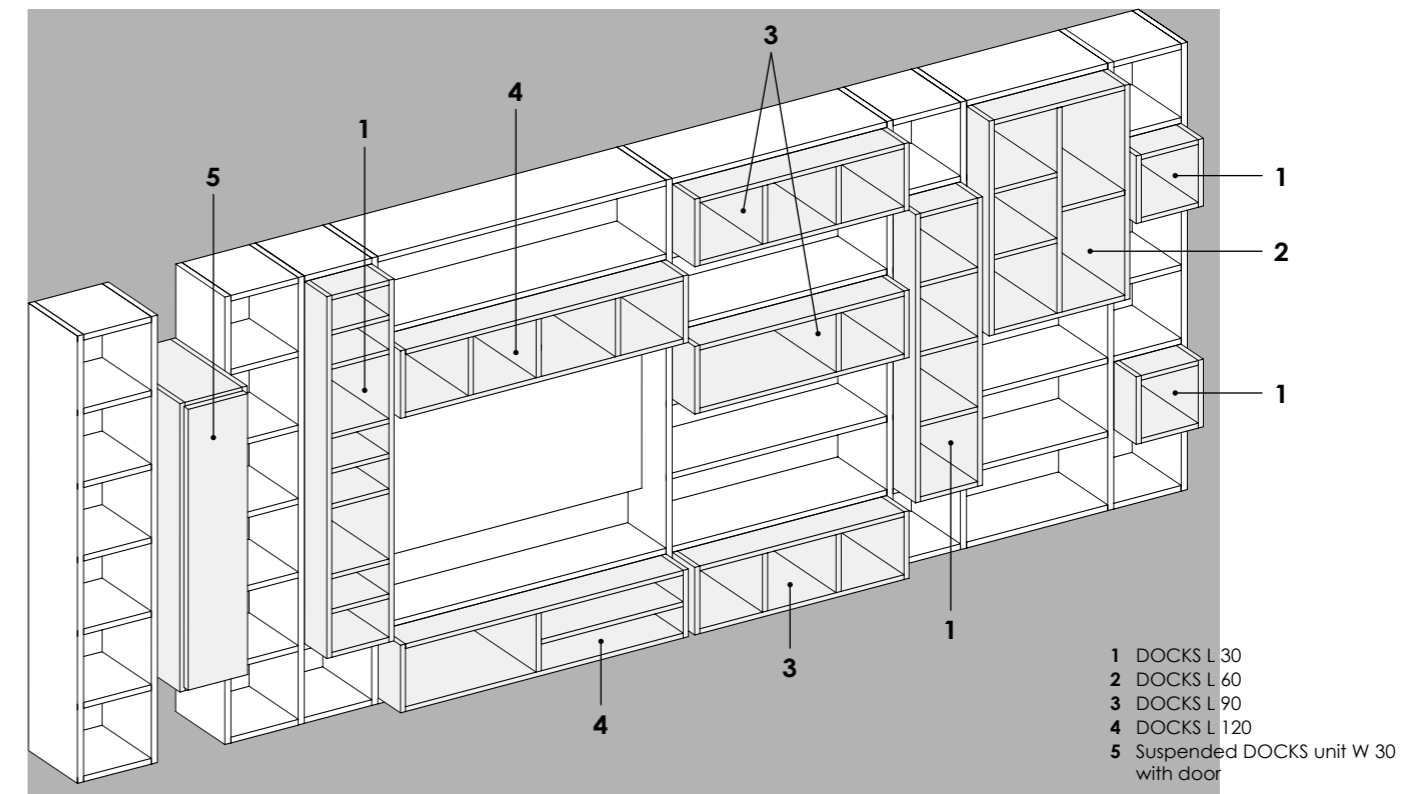

Open  
For W 30

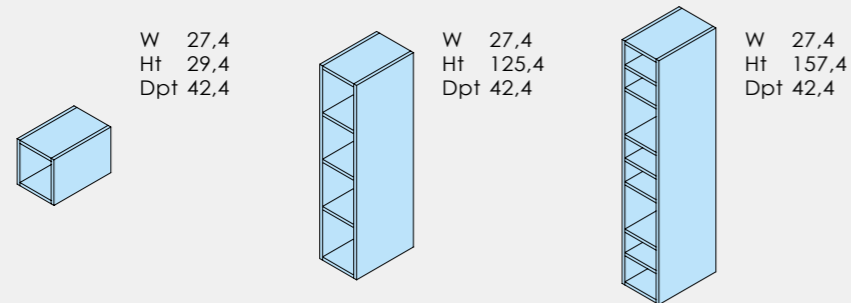

Code	PL98.75U	PL98.76A	PL98.77G	
------	----------	----------	----------	--

Open  
For W 120

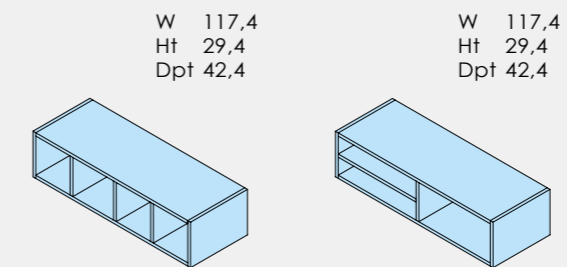

Code	PL98.82E	PL98.83M		
------	----------	----------	--	--

Open  
For W 60

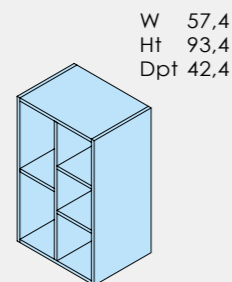

Code	PL98.78P			
------	----------	--	--	--

Suspended unit  
with door

Specify hinge R or L

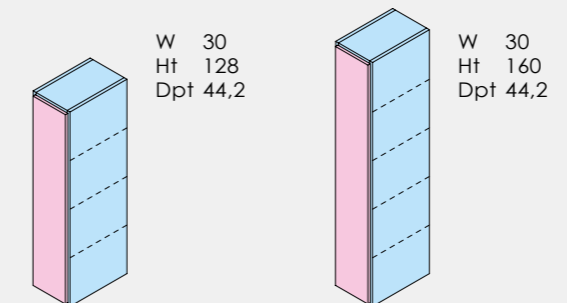

Code	PL98.86F	PL98.87N		
ONE	matte			
	glossy			
CLUB				
WINDOW				

Open  
For W 90

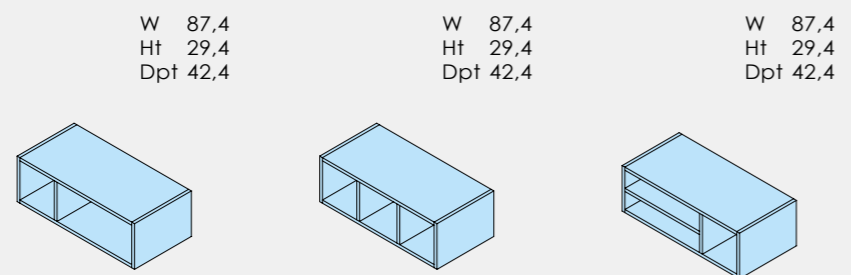

Code	PL98.79V	PL98.80S	PL98.81Y	
------	----------	----------	----------	--

- Components in GROUP 2 colors
- Components in Types and colors FRONT

# MAGIC modular units suspended for bookcases INFINITY

## Dpt 33.3



- They are elements with non modifiable inside partition which can be used as single units or as part of a composition (see example).
- They are provided with concealed anti-unhooking wall fixing system.
- Customer must take care of assembling.
- The doors are fitted with decelerated hinges.
- The doors are also available with push pull (not on CLUB and WINDOW).
- **They can not be rotated.**

Example of composition with **MAGIC-A**

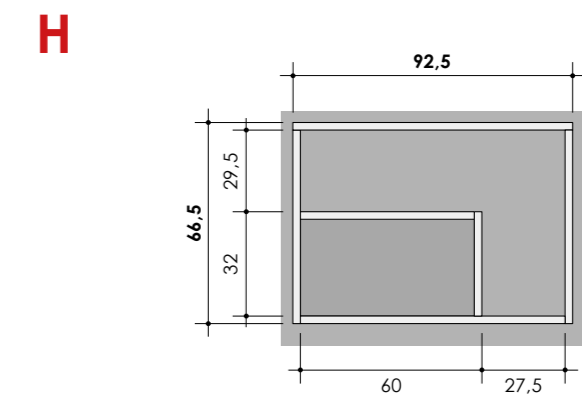
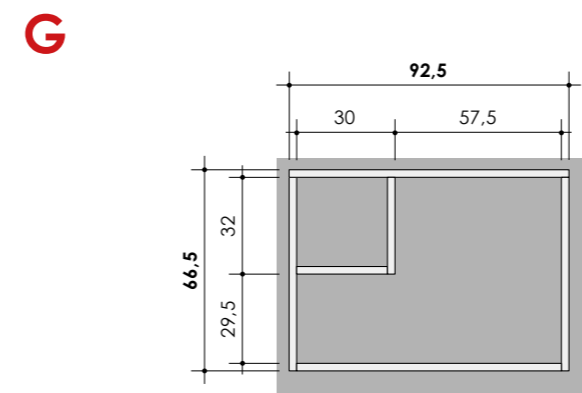
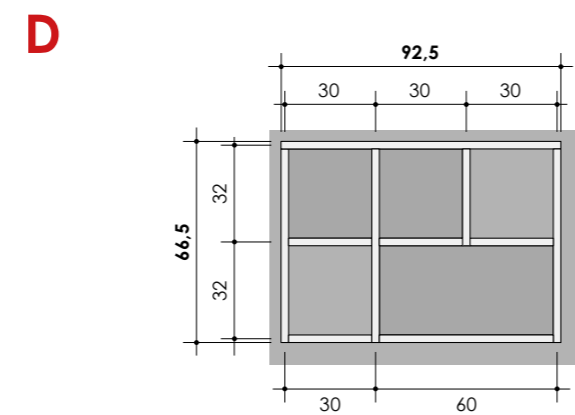
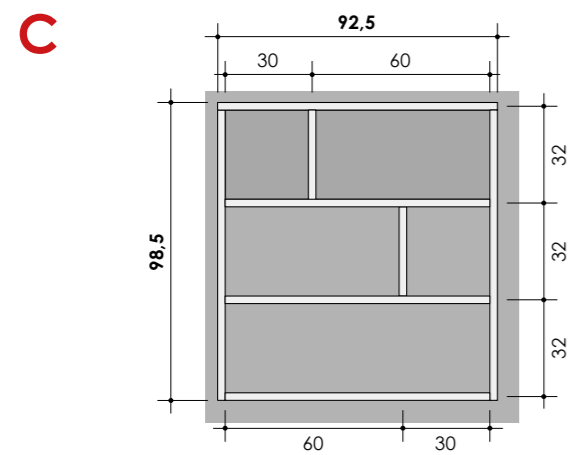
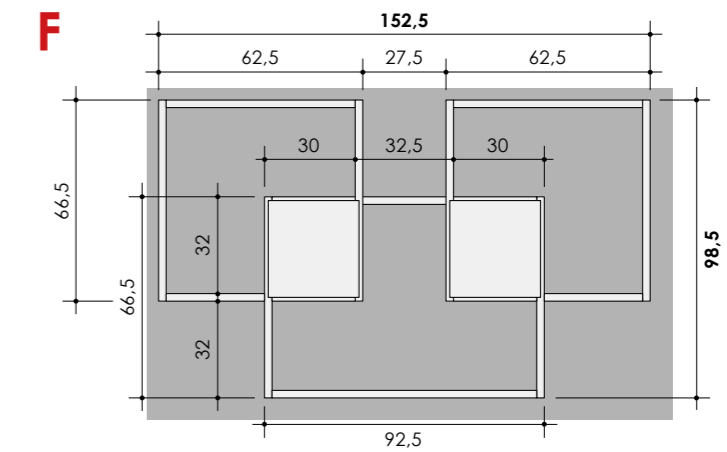
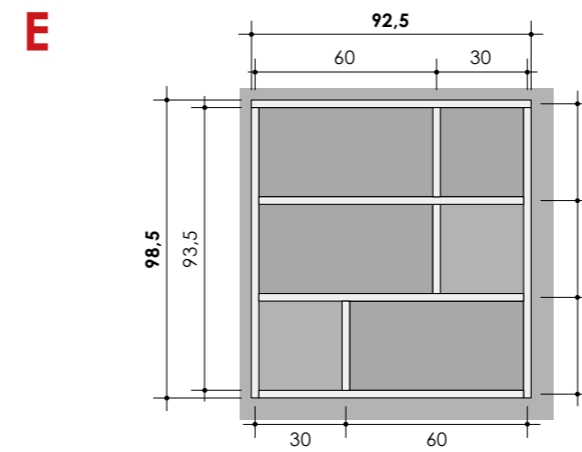
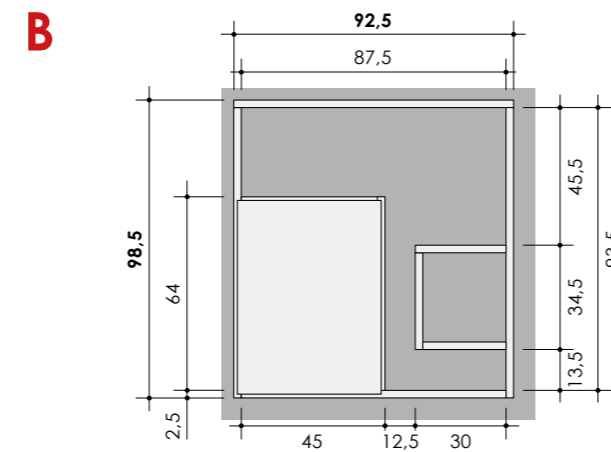
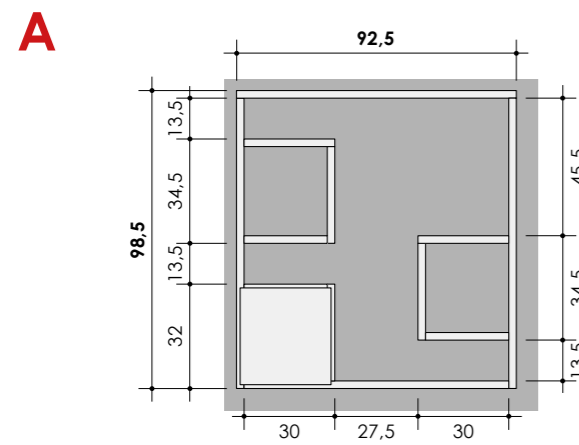
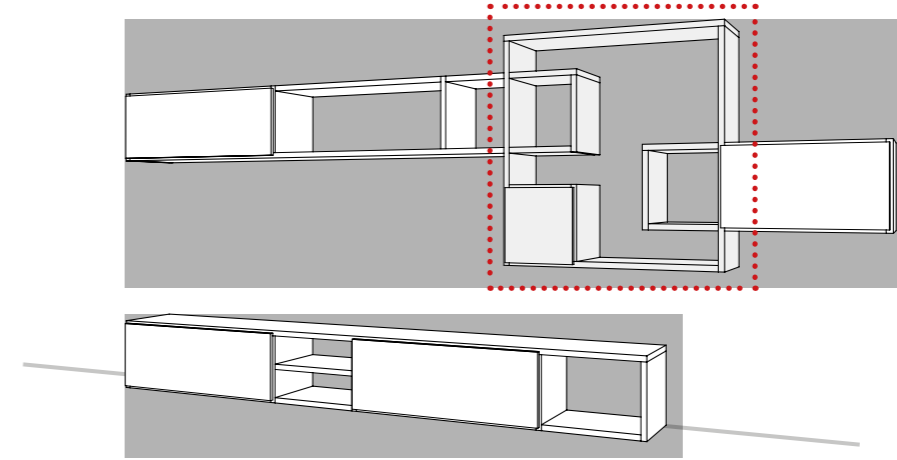

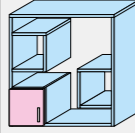
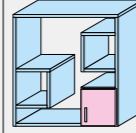
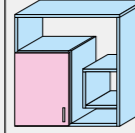
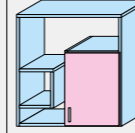
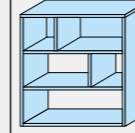
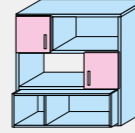
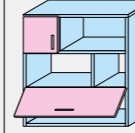
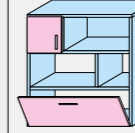
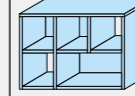
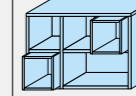
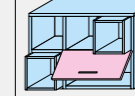

# MAGIC modular units suspended for bookcases INFINITY

## Dpt 33.3

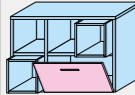
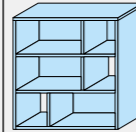
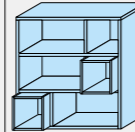
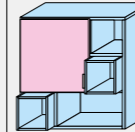
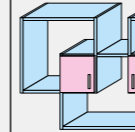
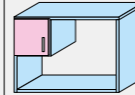
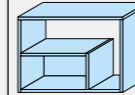
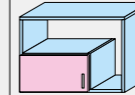
	<b>A</b>		<b>B</b>		<b>C</b>		<b>D</b>				
	Dpt 35,1 Specify hinge R or L	Dpt 35,1 Specify hinge R or L	Dpt 35,1 Specify hinge R or L	Dpt 35,1 Specify hinge R or L	Dpt 33,3	Dpt 42,4 Specify hinge R or L	Dpt 35,1 Specify hinge R or L	Dpt 35,1 Specify hinge R or L	Dpt 33,3	Dpt 42,4	Dpt 42,4
											
<b>Code</b>	<b>PL99.30U</b>	<b>PL99.31A</b>	<b>PL99.32G</b>	<b>PL99.33P</b>	<b>PL99.34V</b>	<b>PL99.35B</b>	<b>PK84.31Y</b>	<b>PK84.32E</b>	<b>PL99.37Q</b>	<b>PL99.38W</b>	<b>PK84.33M</b>
ONE	matte										
	glossy										
CLUB											
WINDOW											

	<b>D</b>	<b>E</b>	<b>F</b>		<b>G</b>	<b>H</b>					
	Dpt 42,4	Dpt 33,3	Dpt 42,4	Dpt 42,3 Specify hinge R or L	Dpt 35,1 Specify hinge R or L	Dpt 33,3	Dpt 35,1 Specify hinge R or L	Dpt 33,3	Dpt 35,1 Specify hinge R or L		
											
<b>Code</b>	<b>PK84.30S</b>	<b>PL99.40Z</b>	<b>PL99.41F</b>	<b>PL99.42N</b>	<b>PL99.43U</b>	<b>PL99.44A</b>	<b>PL99.45G</b>	<b>PL99.46P</b>	<b>PL99.47V</b>		
ONE	matte										
	glossy										
CLUB											
WINDOW											

 Components in **GROUP 2** colors  
 Components in **Types and colors FRONT**



## CAPRI

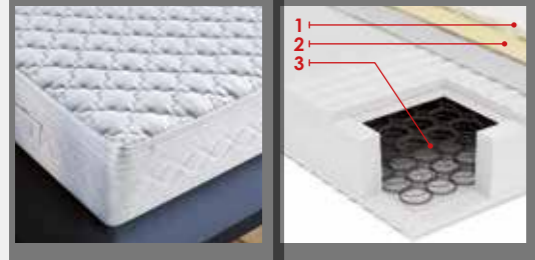

### 400 BONNELL HOURGLASS SPRINGS



**FABRIC:** 1 Elasticised with non-allergenic treatment. Fixed. **PADDING:** 2 Winter side: PolyFill Termal fibre (selected wool + non-allergenic polyester fibre). Summer side: PolyFill Fresh fibre (selected cotton + non-allergenic polyester fibre). **STRUCTURE:** 3 Bonnell double cone springs "400" (density approx. 400 springs, in the double bed version) + very thick polyurethane with shaped profile. **SUPPORT:** Rigid. **THICKNESS:** Ht 17 cm (without handles) and Ht 21 cm (with handles).

## LIPARI

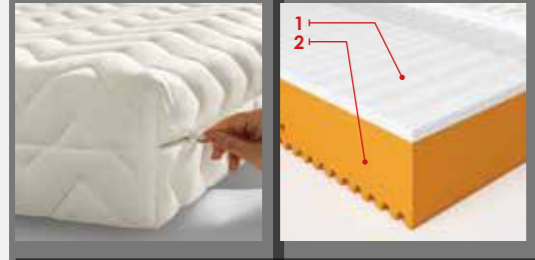

### ECOFOAM (water foamed, breathable open cell)



**COVER:** Removable and washable in water at 30° C. **FABRIC:** Elasticised, non-allergenic treatment and central zipper on three sides. **PADDING:** 100% Polyfill fibre non-allergenic breathable. **STRUCTURE:** 1 EcoFoam layer (expanded open cell polyurethane, water foam) with multizone profile. 2 Very thick EcoFoam layer (open cell polyurethane, water foam) wavy profile. **SUPPORT:** 1 Rigid 2 Medium. **THICKNESS:** Ht cm 17 approx. (plate height cm 15.5 approx.).

## ELBA

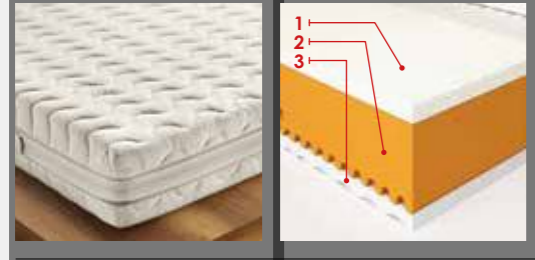

### ECOFOAM + VISCO-ELASTIC MEMORY FOAM



**COVER:** Silver Air: non-allergenic fabric with silver-based treatment, removable and washable in water at 30° C. **FABRIC:** Elasticised, Silver Fresh treatment. **OUTER STRIP:** Air System in reticular, high transpiration, removable fabric with handles and double outer zippers with separation system. **PADDING:** 100% Polyfill fibre non-allergenic breathable, dust-proof (on two sides). **STRUCTURE:** 1 Layer of Thermo Visco Memory Foam (heat-sensitive viscoelastic) Ht cm 3 multi-zone (winter side) multi-zone wave profile. 2 Very thick EcoFoam layer (open cell polyurethane, water foam) medium/high density. 3 Layer of EcoFoam Ultrasoft Ht cm 2.5 (summer side) multi-zone wave profile. **SUPPORT:** Medium/high comfort. **THICKNESS:** Ht cm 21 approx. (plate height cm 18 approx.).

## ALICUDI

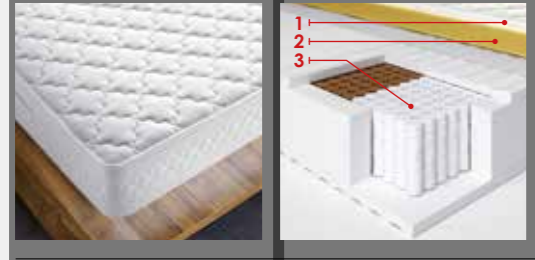

### 1600 MICRO-POCKET SPRINGS



**FABRIC:** 1 Elasticised with non-allergenic treatment. Fixed. **PADDING:** 2 Winter side: Layer of 100% pure Poly-Fill Termal fibre (selected wool + non-allergenic polyester fibre) + polyurethane layer. Summer side: Layer of 100% pure PolyFill Fresh fibre (selected cotton + non-allergenic polyester fibre) + polyurethane layer. **STRUCTURE:** 3 Nested micro-springs (density approx. 1600 springs, in the double bed version) with independent movement with a thick layer of polyurethane with wave profile on two sides. **SUPPORT:** Medium-high. **THICKNESS:** Ht cm 23 approx.

## SALINA

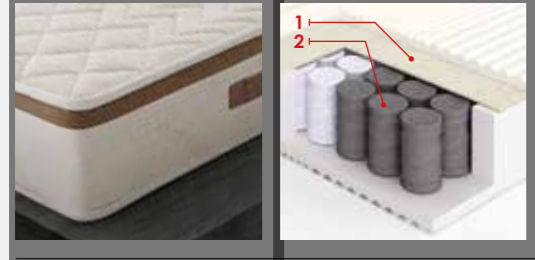

### POCKET MEMORY



**FABRIC:** Elasticised with Aloe Vera non-allergenic treatment. Fixed. **PADDING:** Winter/summer side: double layer in 100% pure PolyFill hypoallergenic with high transpiration fibre. **STRUCTURE:** 1 Thermo-Visco Memory layer 3 cm (on one side) with multi-zone wave profile and EcoFoam layer Ht 2.5 cm approx with multi-zone profile (on one side). 2 Independently moving nested springs in different zones (800/1000 springs approximately for the double version). **SUPPORT:** Medium-high, different on the 2 sides. **THICKNESS:** Ht 23 cm approx.

## PALMAROLA

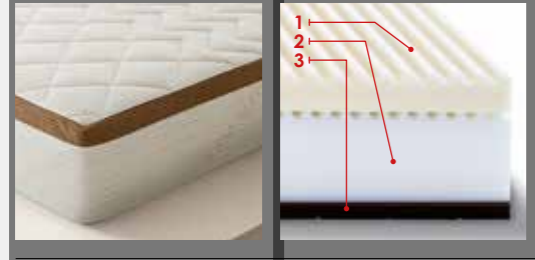

### HIGH COMFORT MEMORY



**FABRIC:** Elastic with non-allergenic Aloe Vera treatment. The cover is removable and washable in water 30° C. **PADDING:** Winter/Summer side: double layer in 100% pure PolyFill hypoallergenic with high transpiration fibre. **STRUCTURE:** 1 Thermo-Visco Memory layer (thermo-sensitive - visco-elastic) Ht 5 cm multi-zone (winter side). 2 EcoFoam middle layer (open-cell polyurethane, water-foamed) with high carrying capacity and wave profile. 3 High elasticity EcoFoam layer Ht 2 cm. (summer side). **SUPPORT:** Medium-high, different on the 2 sides. **THICKNESS:** Ht 22 cm approx. (plate height 19 cm approx.).

## PONZA

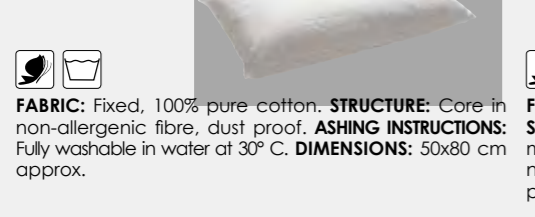

## PROCIDA



## MALVA



**FABRIC:** Fixed, 100% pure cotton. **STRUCTURE:** Core in non-allergenic fibre, dust proof. **ASHING INSTRUCTIONS:** Fully washable in water at 30° C. **DIMENSIONS:** 50x80 cm approx.



**FABRIC:** Elasticised, breathable, non-allergenic. Fixed. **STRUCTURE:** Core in bevelled EcoFoam Ultrasoft with massaging insert in Thermo-Visco Memory Touch in the nape support area. **DIMENSIONS:** 68x38x10/11 cm approx.



**FABRIC:** Elasticised, breathable, non-allergenic. Fixed. **STRUCTURE:** Core in micro-perforated latex with bevelled form. **DIMENSIONS:** 72x42x10 cm approx.

Non-allergenic

Antistatic

Ecological and recyclable

Removable and washable in water

Aloe vera

Fireproof Class IIM (approved by the Ministry of the Interior) with metal point seams on the inner layers

Bonnell system

Micro-pocket 800-1000

Micro-pocket 1600

Water foam

Latex

Not folding

Folding

Complete ergonomics

Double support

Thermo memory foam

# Mattresses, pillows and slatted bed base

## Mattresses



	Ht	w 75		w 80		w 80	
		Code	Kg	Code	Kg	Code	Kg
CAPRI	17	PL39.26H	10,8	PL39.00H	11,5	PL39.41M	12,1
	21	-	-	PL39.01Q	13	PL39.42T	13,7
	21	-	-	PL39.31F	14	PL39.46U	14,7
LIPARI	17	PL39.27Q	7,5	PL39.02W	8	PL39.43Z	8,4
ELBA	21	-	-	PL39.03C	10	PL39.44F	10,5
ALICUDI	23	-	-	PL39.04K	14,8	PL39.45N	15,5
SALINA	23	-	-	-	-	-	-
PALMAROLA	22	-	-	-	-	-	-

	Ht	w 90		w 90		w 120		w 120	
		Code	Kg	Code	Kg	Code	Kg	Code	Kg
CAPRI	17	PL39.05R	12,9	-	-	-	-	-	-
	21	PL39.06X	14,6	PL39.10P	15,4	PL39.14Q	19,5	PL39.53E	20,5
	21	PL39.32N	15,8	PL39.33U	16,6	PL39.34A	21	-	-
LIPARI	17	PL39.07D	9	PL39.11V	9,5	PL39.15W	12	PL39.55T	12,6
ELBA	21	PL39.08L	11,3	PL39.12B	11,8	PL39.16C	15	PL39.56Z	15,8
ALICUDI	23	PL39.09S	16,6	PL39.13H	17,5	PL39.17K	22,1	PL39.57F	23,3
SALINA	23	-	-	-	-	-	-	-	-
PALMAROLA	22	-	-	-	-	-	-	-	-

	Ht	w 140		w 150		w 160		w 160	
		Code	Kg	Code	Kg	Code	Kg	Code	Kg
CAPRI	17	-	-	-	-	-	-	-	-
	21	PK52.40D	23,9	PK52.44E	25,7	PL39.18R	26	PL39.22G	27,4
	21	-	-	-	-	PL39.35G	28	PL39.36P	29,5
LIPARI	17	PK52.41L	14,7	PK52.45M	15,8	PL39.19X	16	PL39.23P	16,8
ELBA	21	PK52.42S	18,4	PK52.46T	19,7	PL39.20U	20	PL39.24V	21,1
ALICUDI	23	PK52.43Y	27,2	PK52.47Z	29,1	PL39.21A	29,5	PL39.25B	31,1
SALINA	23	-	-	-	-	PL39.58N	35	PL39.59U	36,8
PALMAROLA	22	-	-	-	-	PL39.60R	20	PL39.61X	21,1

	Ht	w 180		w 200		Pillows	
		Code	Kg	Code	Kg	Code	Code
CAPRI	17	-	-	-	-		
	21	PL39.62D	30,8	PK52.48F	34,2		
	21	PL39.68T	33,2	-	-		
LIPARI	17	PL39.63L	18,9	PK52.49N	21,1		
ELBA	21	PL39.64S	23,7	PK52.50K	26,3		
ALICUDI	23	PL39.65Y	34,9	PK52.51R	38,8		
SALINA	23	PL39.66E	41,4	PK52.52X	46,1		
PALMAROLA	22	PL39.67M	23,7	PK52.53L	26,3		

## Slatted bed base

W	Code	Without feet		With foldable feet (W 80/90) With removable feet (W 120/160/180) Ht 29		With wheels and folding feet For pull-out base Ht 5 ÷ 30		TUBULAR MEMBERS: 40 x 28 mm tubular members with high strength 30 x 30 cross bars. SLATS: 14+14 birch slats of 68 x 8 mm. 14 birch whole slats of 68 x 8 mm (for W 90 - 120). PAINTING: Black epoxy powder painted finish.
		Code	Code	Code	Code			
80 x 190	P48.54T	P48.61F	P48.53N	-	-	-	-	
90 x 190 x 200	P48.85M	P48.83A	-	-	-	-	-	
120 x 190 x 200	P48.59V	P48.23Z	-	-	-	-	-	
160 x 190 x 200	P49.32B	P48.49R	-	-	-	-	-	
	P35.54F	P35.53A	-	-	-	-	-	
180 x 200	PL39.48G	-	-	-	-	-	-	



# Certifications



UNI EN ISO 14001



UNI EN ISO 9001

# Colour codes and names

In alphabetical order:

Colour codes		Colour names		
0013	Pink	<b>• A</b>	Mais	0503
0014	Taupe	AP4B	Malta	ML7H
0016	Camel	GV7A	Malva	Z63U
0019	Forest	AL1A	Marrone	BE01
0020	Turquoise	AL5Z	Marrone Woody	Z59K
0100	Bianco	LM7A	Menta	MN4K
0102	Seta	Z15L	Moka	MK6B
0111	Ottico	Z31L	<b>• N</b>	
0303	Bombay	Z27R	Navy	NA4S
0314	Strawberry	0600	Nero	BE07
0402	Zinc	AR3T	Nero	NE8K
0403	Papyrus		Nero Nice	K40X
0415	Testa di moro		Nero opaco	NP7H
0503	Carioca	BS5T	Nero spazzolato	NR4B
0503	Mais	Z25H	Nero Step	K33Z
0600	Argento	0100	Noce	NC4B
0601	Grey	BN7A	Noce naturale	NN7H
0603	Tenda	Z20B	<b>• O</b>	
0604	Greystone	Z30R	Oceano	0700
0605	Creta	K28F	Opale	Z85V
0607	Tortora	K38R	Oran	OR1S
0608	Fumo	BI7A	Orange	Z24B
0700	Oceano	K32W	Bianco opaco	OR8R
0704	Smoke	BU3Q	Bianco Step	K03V
0706	Steel	Z56W	Bianco UV	
0805	Water green	K07H	Bianco Woody	0111
0900	Pill	BE04	Blauw	
0901	Violetto	BL6R	Blu	K05B
0903	Nox	K36K	Blu	Y33R
0905	Coriander	BI4B	Blu Benna	0403
<b>• A</b>		BO7H	Blu indaco	0900
AL1A	Alluminio	Z16R	Blu opale	0013
AL5Z	Alluminio	Z70R	Blu pervinca	0013
AP4B	Acciaio opaco	Z303	Blu petrolio	Z87B
AR3T	Argento		Bombay	
<b>• B</b>			<b>• C</b>	
BE01	Marrone	CQ3Q	Cadaques	Z66H
BE02	Rosso	0016	Camel	K04Y
BE03	Verde	CN1X	Canapa	RS8X
BE04	Blu	Z57T	Canapa Woody	RB7Y
BE05	Grigio	CG8X	Carbon grey	BE02
BE06	Grigio scuro	0503	Carioca	K34C
BE07	Nero	CM3Q	Cemento Masdar	Z32B
BI4B	Blu indaco	CH2M	Champagne	K30N
BI7A	Bianco opaco	CH7Y	Champagne spazzolato	RO3R
BL6R	Blue	CB6K	Ciliegio bianco	RD5T
BN7A	Bianco	CP4J	Cipria	RW33Q
BO7H	Blu opale	CR5T	Corallo	<b>• S</b>
BS5T	Basalto	0905	Coriander	Sabbia Luna
BT4R	Trasparente	0605	Creta	K29K
BU3Q	Bianco UV		<b>• D</b>	K39U
<b>• C</b>		DS9L	Desert	0102
CB6K	Ciliegio bianco	Z81G	Desert	Z79Y
CG8X	Carbon grey	DM7P	Domy	SV8X
CH2M	Champagne	Z83P	Domy	0704
CH7Y	Champagne spazzolato	Z80B	Dorian	SP7L
CL1X	Eucalipto	Z67M	Duna	0706
CM3Q	Cemento Masdar		<b>• E</b>	ST3S
CN1X	Canapa	Z64X	Elephant	ST6P
CP4J	Cipria	CL1X	Eucalipto	0314
CQ3Q	Cadaques		<b>• F</b>	
CR5T	Corallo	Z58R	Fango Woody	
<b>• D</b>		FL8X	Feltro	
DM7P	Domy	Z62R	Fiordaliso	
DS9L	Desert	Z69T	Forest	
<b>• F</b>		Z70R	Fumo	
FL8X	Feltro	Z39A	Geel	
FT8P	Trasparente fumé	Z40T	Giallo fluo	
<b>• G</b>		Z41G	Giallo fluo	
GF2B	Giallo fluo	Z56W	Giallo Fruit	
GL4R	Grigio Dorian	Z57T	Giallo Fruit	
GL7H	Grigio Londra	Z58R	Giallo Soft	
GV7A	Agave	Z26N	Giallo zafferano	
GZ8A	Giallo zafferano	Z59K	Grey	
GZ8T	Grigio titanio	Z62R	Greystone	
<b>• I</b>		Z63U	Grigio	
IC9R	Ice	Z64X	Grigio	
<b>• K</b>		Z66H	Grigio Benna	
K01P	Wit	Z67M	Grigio Dorian	
K02S	Geel	Z68Q	Grigio Fruit	
K03V	Oranje	Z69T	Grigio Londra	
K04Y	Rood	Z70R	Grigio medio	
K05B	Paars	Z71U	Grigio medio	
K06E	Groen	Z79Y	Grigio polvere	
K07H	Blauw	Z80B	Grigio scuro	
K28F	Bianco Luna	Z81G	Grigio scuro Luna	
K29K	Sabbia Luna	Z82L	Grigio titanio	
K30N	Rosso Luna	Z83P	Groen	
K31T	Grigio scuro Luna	Z84S	<b>• I</b>	
K32W	Bianco Step	Z85V	Ice	
K33Z	Nero Step	Z86Y	Ice	
		Z87B	Limone	
			Limone	
			<b>• M</b>	